

GUIDELINES FOR REPRESENTATION OF NETWORK ELEMENTS WHEN CALCULATING TRANSIENTS

**Working Group 02 (Internal overvoltages)
Of Study Committee 33
(Overvoltages and Insulation Coordination)**

1. Introduction

The methods of computation of transients in electric power systems and the representation of network components have been already studied in the past, particularly by CIGRE Working Groups /1, 2, 3, 4/. These studies mainly refer to the computation of switching overvoltages.

Meanwhile, however, new problems have become important (e.g. stresses of metal oxide surge arresters by temporary overvoltages, very fast transients in GIS) and new facilities are available (e.g. highly developed digital computer programs /5, 6/, new electronic devices on TNA's for the simulation of components and for their automatization /7/).

At present, digital computer programs theoretically allow to cover the requirements for studies of all transients. In fact digital computers at present are almost exclusively used when studying power frequency phenomena in systems and lightning and very fast transient phenomena in substations.

The analog representation by TNA's is still extensively used, especially where actual control equipment (e.g. HVDC-, Static Var Compensator (SVC)- and Power System Stabilizer (PSS)-controllers) or protective equipment (e.g. digital distance relays) can be connected to the TNA to study its interaction with the electrical system.

Digital programs offer the advantage of continuous availability of the computer, which also can be used simultaneously for different studies. On the other hand TNA's may offer advantages in performing extensive statistical analyses, particularly if they are automatized, and they offer the solutions in real time, whereas digital programs for the calculation of electromagnetic transients still have a execution time considerably slower.

The application of TNA's and of relevant digital computer programs has been compiled by CIGRE WG 33.02 and discussed at the SC 33-Colloquium 1985 in Budapest. Based on worldwide experience this report presents a review of the methods to represent components of power systems when calculating electrical transients in such systems.

2. Electrical transients and associated frequency ranges

The study of electrical transient phenomena in power systems involves a frequency range from DC to about 50 MHz or in specific cases even more. Above power frequency these usually involve electromagnetic phenomena, whereas below power frequency also transients of the electromechanical type in rotating machines can be involved.

Transient phenomena appear as transitions from one steady state condition to another. The primary cause of such disturbances in a system are closing or opening of a breaker or another switching equipment, short-circuits, earth faults or lightning strokes. The consequential electromagnetic phenomena are travelling waves on lines, cables or busbar sections and oscillations between inductances and capacitances of the system. The frequencies of the oscillations are determined by the surge impedances and travel times of connecting lines resp. by the inductances and capacitances involved (e.g. short circuit impedance of feeding system and capacitance of switched line).

Table 1 gives an overview on the various origins of such transients and their most common frequency ranges. Minimum frequency values below power frequency indicate the frequency band required to represent main time constants of the relevant transients.

Table 1: Origin of electrical transients and associated frequency ranges (most common values)

Origin	frequency range
Transformer energization ferroresonance	(DC) 0.1 Hz - 1 kHz
Load rejection	0.1 Hz - 3 kHz
Fault clearing	50/60 Hz - 3 kHz
Fault initiation	50/60 Hz - 20 kHz
Line energization	50/60 Hz - 20 kHz
Line reclosing	(DC)50/60Hz - 20 kHz
Transient recovery voltage	
Terminal faults	50/60 Hz - 20 kHz
Short line faults	50/60 Hz - 100 kHz
Multiple restrikes of circuit breaker	10 kHz - 1 MHz
Lightning surges, faults in substations	10 kHz - 3 MHz
Disconnecter switching (single restrike) and faults in GIS	100 kHz - 50 MHz

In some cases the total duration of electrical transients may last longer than indicated in the table (e.g. saturation phenomena during energization of large transformers), but normally their behaviour during shorter time periods is of real interest. On the other hand for practical investigations also switching sequences of long duration may be split up into separate single events of shorter duration if there exist quasi-steady-state conditions inbetween (e.g. single restrikes during disconnecter switching).

3. General aspects on representation and classification of frequency ranges

Representations which are valid throughout the complete frequency range of 0 (DC) to 50 MHz are practically not possible for all network components. For this reason, those physical characteristics of a specific network element which have a decisive effect on the particular portion of the transient phenomena, which is of interest, must be given detailed consideration, e.g.

- the saturation characteristics of transformers and reactors can be of importance, in case of fault clearing, transformer energizing and if significant temporary overvoltages are expected.

- when switching on a line, if the main interest is concentrated on the maximum overvoltage which occurs, the line characteristics and the feeding network are of importance. However, if also details of the initial rate of rise of the overvoltages are of importance, even detailed characteristics of the substation, e.g. capacitances of measuring transformers, the number of outgoing lines and their surge impedances are decisive to the travelling wave phenomena determining the initial shape of the overvoltage.

- when studying phenomena with frequencies above 1 MHz such as very fast transients in GIS caused by disconnector restrikes, not only the waves travelling on the busbar sections may be of importance but also the very small additional capacitances and inductances of measuring transformers, post insulators and in some cases even the elbows in the tubular busbars.

The representation of the individual network elements must therefore correspond to the specific frequency range of the particular transient phenomena. For that reason the frequency ranges of electrical transients in Table 1 will be classified as four typical groups with overlapping frequency ranges for which specific representation models may be established (see Table 2). These groups are related to the actual steepness of overvoltages but for simplification reasons they will be designated also by typical origins of transients. Not in all cases, however, they are the real origin of an overvoltage of the relevant group (e.g. faults or switching operations may create also steep front surges in the local vicinity of their origin).

The TNA techniques mostly refer to Groups I and II, but it is possible to apply TNA's also at higher frequencies by changing the time scale.

Table 2: Classification of frequency ranges

Group	frequency range for representation	shape designation	representation mainly for
I	0.1 Hz - 3 kHz	Low frequency oscillations	Temporary overvoltages
II	50/60 Hz - 20 kHz	Slow front surges	Switching overvoltages
III	10 kHz - 3 MHz	Fast front surges	Lightning overvoltages
IV	100 kHz - 50 MHz	Very fast front surges	Restrike overvoltages

4. Representation of network components

Various parameters may have different influences on the correct representation of the components within each of the four groups of frequency ranges. Their importance is designated below by "negligible", "important" and "very important". Parameters designated "very important" should be taken into account very carefully for all studies, whereas parameters

designated by "important" should be represented as correct as possible particularly when specific cases are to be verified, e.g. by comparisons between field tests and calculations. Very often and especially in the planning stage exact system data are not known. In such cases parameters designated by "important" may be represented by a simplified method but their values should be varied to check the sensitivity of the results.

4.1 Overhead transmission lines

An overview of representation methods for single circuit lines and of the influence of the relevant parameters is shown in Table 3. Within frequency Groups I and II different representation methods are used for TNA's and digital computer programs. For Group II on TNA's very often additional damping resistances R_{lp} resp. R_{Ep} may be necessary to adjust it to the real line behaviour and to damp out spurious oscillations of higher frequencies caused by the representation of the line by a finite number of π -sections /3/.

Transmission lines can be represented in digital computer programs in principle in a similar way as for TNA. However, normally a travelling wave approach is applied. Accordingly, the surge impedance (or admittance) matrix and the propagation characteristics of the lines are introduced. Mathematical transformations that allow application of the different modes of propagation are used (particularly in the lower frequency ranges according to Groups I and II the propagation speed of electromagnetic waves in the ground mode of overhead lines with 0.2 to 0.25 km/ μ s is lower than the propagation speed of about 0.3 km/ μ s in their line mode). Except for lightning overvoltages, earth wires may be eliminated assuming zero voltage on those wires. Accordingly the impedance (admittance) matrices are reduced to 3 x 3 matrices, and e.g. the α/β -transformation /3/ can be used. For studies of lightning overvoltages (Group III), particularly in backflashover cases, the earth wires must also be included and each span of the line has to be handled separately. Transformations in order to decouple the n-conductor system to n independent equivalent single conductor systems are necessary. Such transformations are found by eigenvalue analysis. For this kind of overvoltages also corona losses /1, 8/ and the influence of towers should be included in the computation model. More detailed studies on correct overhead line simulations for Group III transients at present are worked out by CIGRE WG 33.01 (Lightning). For Group IV transients in most cases it is sufficient to represent an overhead line connected to the GIS by its surge impedance.

4.1.1 Number of π -sections and choice of time step

4.1.1.1 Number of π -sections

The number m of π -sections required for the correct representation of lines depends mainly on the expected frequency of the transient oscillation. The highest frequency f_{max} that can be attained by a π -section representation is the natural frequency of one individual element representing a partial length $s = s_{tot}/m$ of the total line length s_{tot} . With $L = s \cdot L'$ and $C = s \cdot C'$ it results

$$f_{max} = \frac{1}{2\pi s \sqrt{L' \cdot \frac{C'}{2}}} = \frac{v}{4.44 \cdot s}$$

Table 3 : Representation of overheadlines

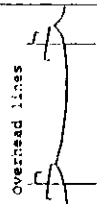
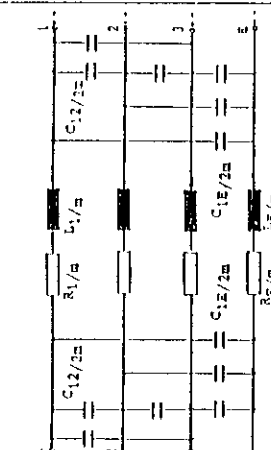
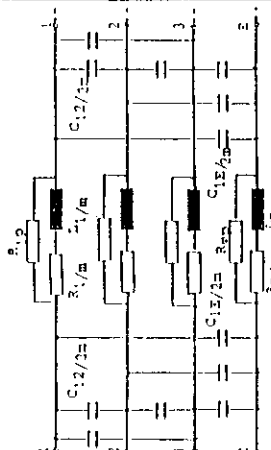
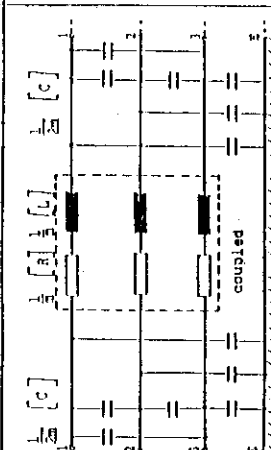
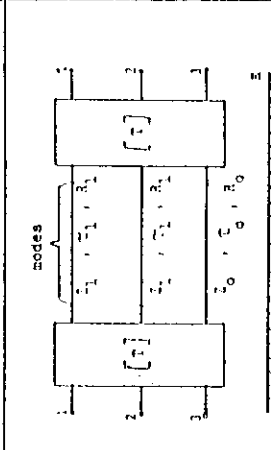
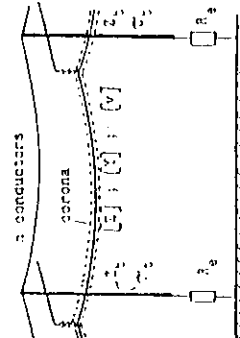
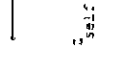
Overhead lines	Group I 0.1 Hz ± 3 kHz	Group II 50/60 Hz ± 20 kHz	Group III 10 kHz ± 3 kHz	Group IV 100 kHz ± 10 kHz
				
TMA representation (balanced line)	 <p> $R_2 = \frac{1}{2} (R_0 - R_1)$; $L_2 = \frac{1}{2} (L_0 - L_1)$ $C_0 = C_{1E}$; $C_1 = C_0 + 3C_{12}$ $m = 1, \dots, 5$ </p>	 <p> $R_2 = \frac{1}{2} (R_0 - R_1)$; $L_2 = \frac{1}{2} (L_0 - L_1)$ $C_0 = C_{1E}$; $C_1 = C_0 + 3C_{12}$; $Z_1 = \sqrt{\frac{L_1}{C_1}}$; $Z_0 = \sqrt{\frac{L_0}{C_0}}$ $R_{1p} = (5, \dots, 10) Z_1$; $R_{2p} = (5, \dots, 10) \cdot \frac{1}{2} (Z_0 - Z_1)$ $m = 1, \dots, 10$ </p>	not used	not used
Digital computer representation (balanced line)	 <p> $[R]$ is 3 x 3 matrix with diagonal = $(R_0 + 2R_1)/3$ Off diagonal = $(R_0 - R_1)/3$; $m = 1, \dots, 5$ </p>	 <p> Transformation made to phase with $[T]$ Z_0, C, R_0 </p>	 <p> Z_0 = surge impedance man matrix C = capacitance man matrix V = travelling wave velocity n-matrix Z_1 = tower surge impedance m = tower travelling time R_2 = tower footing resistance </p>	 <p> Z_{self} $Z_{self} = \frac{1}{2} Z_0 - \frac{1}{2} Z_1$ </p>
Line	important	important	important	negligible
Capacitive	important	important	important	negligible
Inductive	important	important	important	negligible
Frequen- ground	important	important	important	important
ry depen- nodes (Z_0)	important	important	important	important
dent PA- axial	negligible	negligible	negligible	negligible
parameters nodes (Z_1)	important if $U > U_0$	important	important	important
Corona effects	important	important	important	important

L = inductance
 R = ohmic resistance
 C = capacitance
 Z = surge impedance
 v = travel time
 f = frequency
 Index 1: positive sequence system
 Index 0: zero sequence system
 Index 12 resp. 13: between phases
 Index 1E resp. 1E: phase to earth

with $v = \frac{1}{\sqrt{L' \cdot C'}} =$ propagation speed of electromagnetic wave

and $L' =$ line-inductance per unit length
 $C' =$ line-capacitance per unit length

Thus, as a rule of thumb, for practical purposes if a maximum frequency f_{\max} has to be represented, the length s_{\max} of a line section represented by a single π -section should not be longer than

$$s_{\max} = \frac{v}{5 \cdot f_{\max}}$$

On the other hand that means that on a TNA having an inherent upper frequency limit of $f_{\max} = 20$ kHz, the line length per π -section of an overhead line representation needs not to be shorter than about 3 km (propagation speed $v \approx 0.3$ km/ μ s).

If lower frequencies are expected only, e.g. for temporary overvoltages (Group I) of maximum frequencies below 300 Hz, line lengths of about 200 km per π -section are permissible i.e. in such cases all lines with length below 200 km can be represented by one π -section.

However, besides the maximum frequency to be represented also other parameters such as rise time, attenuation or phase shift may require special consideration. For more detailed information on their influence on maximum line length per π -section see /9/.

Care has to be taken also if the first capacitance of the first π -section of a line representation is switched immediately in parallel to a capacitance of the feeding system side. In such cases an ohmic resistance in the order of the surge impedance of the line should be connected in series with that first shunt capacitance. This damps the unrealistic current oscillations. Also a representation by T-sections (one half section impedance on both sides of total section capacitance /1/) instead of π -sections can be used in such cases.

4.1.1.2 Time step

When using digital computer programs the selection of the time step Δt is of importance. On the basis of the highest expected frequency and assuming that ten points would define one period of this frequency f_{\max} with sufficient accuracy, Δt is given by the equation

$$\Delta t \leq \frac{1}{10 \cdot f_{\max}}$$

Some programs use linear interpolation on past values if travel time τ is not an integer multiple of Δt , while others require τ_1, τ_0 to be rounded to the nearest integer multiple of Δt . The first approach introduces damping and the second one shifts resonance frequency. When representing systems with lines of various length, additional care must be taken that Δt is less than the travelling time of the shortest line. Otherwise that line has to be represented by a lumped series-L or shunt-C, the one which is more important.

In case of doubt apply the following rule: The representation is accurate enough, if doubling the number m of π -sections resp. halving the time step Δt does not effect that part of transient which is of interest.

4.1.2 Frequency dependent parameters

The frequency dependent parameters especially of the ground mode (zero sequence system, ground return) have an important influence on most of the transients. Typical dependencies of $R(f)$ and $L(f)$ of 420-kV- and 765-kV-transmission lines are given in /3/. For lightning overvoltages (Group III), however, these dependencies are of secondary importance compared to the effect of earth wires, tower surge impedance, tower footing resistance, insulation flashovers and corona losses. Therefore in that Group line characteristics, model transformation matrices etc. may be determined at one single frequency (for instance 250 kHz) and considered constant.

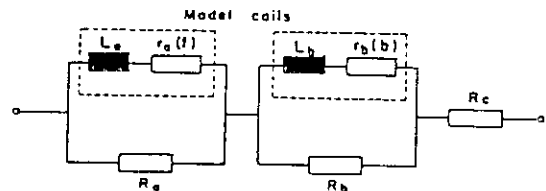

a) Representation of ground return

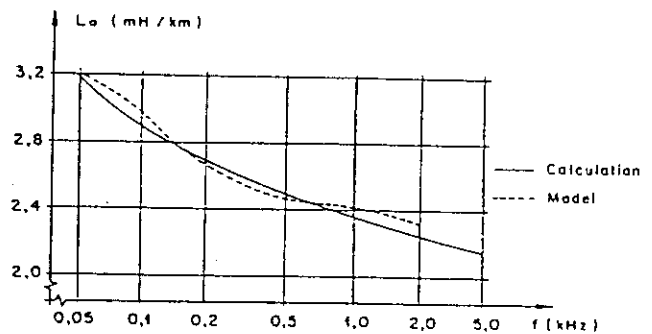

b) Zero sequence inductance characteristic

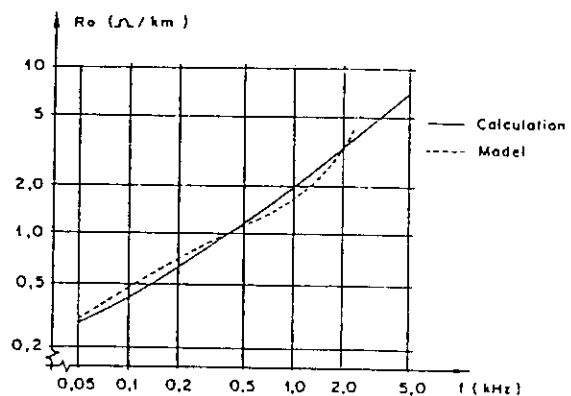

c) Zero sequence resistance characteristic

Fig. 1: Example of a frequency dependent ground return representation for TNA's /3/

Also in other cases of transients consisting mainly of a single frequency oscillation, e.g. when switching-on an unloaded line via an inductive source,

fixed values corresponding to the characteristic ground mode values at this particular frequency may be used for simplification of the calculations. More accurate modelling of the frequency behaviour is necessary in case of multiple frequency transient phenomena. With TNA's this can be realized either by a more sophisticated ground return representation using a suitable combination of various series and parallel connected inductances and resistances as shown in Fig. 1. /3/ or by specially designed coils as shown in Fig. 2 utilizing magnetic and eddy current phenomena similarly to the true properties of the ground return /10/.

For digital computer programs distortion functions are applied which modify the travelling waves by a convolution technique /11/. The frequency dependence of R and L is caused by skin effect in the conductors, and more importantly, by skin effect in the earth, with the current flowing closer to the surface of the conductors and the earth as the frequency f increases.

For round and tubular conductors, there are closed-form solutions $R(f)$ and $L_{\text{internal}}(f)$ with modified Bessel functions, which are usually replaced by polynomial approximations in computer programs. Steel reinforced aluminum conductors are often approximated as tubular conductors by ignoring the steel core. Numerical methods based on finite elements or on subdivision into partial conductors, which are small enough to assume uniform current density can be used as well. In /12/ and in similar approaches, the partial conductors are described by a diagonal resistance matrix and a full inductance matrix with self and mutual inductances, from which $R(f)$ and $L(f)$ are obtained by matrix reduction. On TNA's $R(f)$ and $L(f)$ are usually synthesized as R-L networks. With the approach of Appendix 1, this R-L network is synthesized directly.

For the frequency-dependent earth return impedance, Carson /13/ and Pollaczek /14/ developed formulas with integrals, which are usually approximated by series in computer programs. In handbooks, only a few terms of these series are retained, which is only acceptable at low frequencies. Numerical methods based on subdivision into partial conductors can be used for the earth return as well /16/. More recently, Dubanton and Gary /15/ have developed simple closed-form solutions by adding a complex depth $p = \sqrt{\rho / (j2\pi f \mu_0)}$ to the conductor height, which give results very close to those from Carson's and Pollaczek's formulas ($\rho =$ earth resistivity, $\mu_0 =$ permeability constant).

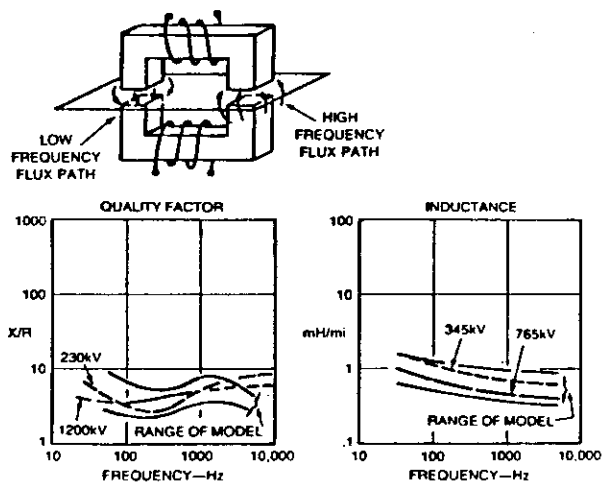

Fig. 2: Specially designed coil for ground return representation /10/

4.1.3 Line asymmetry and coupling with other circuits

4.1.3.1 TNA representation

For Group I and II phenomena line asymmetry and coupling to other circuits including also frequency dependence can be modeled in sufficient detail on TNA's. However, such models are somewhat more complex than shown in Table 3 for balanced lines. Fig. 3 shows an example of a practically used line section representation for non-transposed asymmetrical overhead lines. It incorporates self and mutual inductances of the phase conductors as well as the effects of earth. The capacitance representation is completely general and models phase to ground and phase to phase capacitances. If the components are designed with care proper frequency response and quality factor X/R can be achieved.

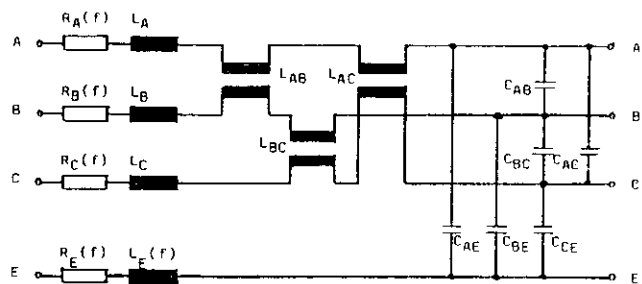

Fig. 3: Line section representation for asymmetrical overhead line configurations

With parallel lines on the same right of way experience shows that generally the modelling of the capacitive coupling is sufficient for switching surge studies (Group II). Special care has to be taken when modelling parallel lines on different right of ways or lines in interconnected networks if they have different ratios X_0/X_1 since in such cases it is important to force the ground return currents through the appropriate earth return branch. In case of lines assumed to be fully symmetrical this can be realized by a representation in $\alpha/\beta/0$ -components. For asymmetrical lines it is necessary to represent the mutual impedance between conductors and earth return by special transformers which make sure, that the sum of the three currents in the conductors is equal to the current flowing back through the ground return (see Fig. 4).

4.1.3.2 Digital representation

With π -sections, the line asymmetry and coupling to other circuits can easily be taken into account if the $(n \times n)$ $[R]$ -, $[L]$ - and $[C]$ -matrices of Table 3 (Group I), with equal diagonal and off-diagonal elements, are replaced with $(n \times n)$ matrices where these elements are no longer equal. For two coupled circuits, n would be 6. The frequency dependence of parameters is difficult to represent in π -sections, unless the n -conductor matrix representation commonly used in computer programs is replaced by an $(n+1)$ -conductor representation similar to Fig. 3.

For the travelling wave approach usually preferred in computer programs, the transformation from phase to mode quantities is no longer known a priori in case of line asymmetry. Instead, the transformation matrices must be calculated for each particular line

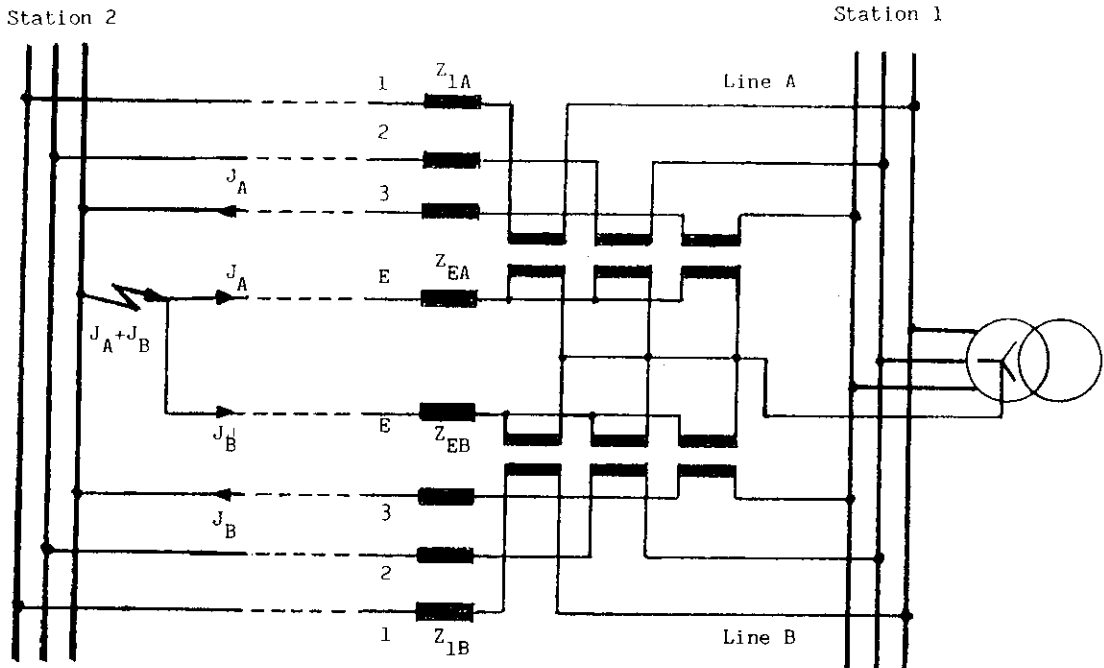

Fig. 4: Representation of earth return currents in meshed systems
(Example of an earth fault)

geometry; they are the eigenvectors of $[Z'] [Y']$ for the voltages, and of its transpose for the currents, with $[Z']$ and $[Y']$ being the series impedance and shunt admittance matrices per unit length.

Strictly speaking, these transformation matrices are frequency-dependent with complex values, but most programs approximate them as constant matrices with real values. For open-circuit voltages, this approximation appears to be reasonable from DC to tens of kHz (Groups I and II), while for short-circuit currents the lower limit of validity lies around tens of Hz for single circuits, or as high as 1 kHz for double and triple circuits /17/. For lightning surge studies (Group III), a constant transformation matrix evaluated at a few hundred kHz gives reasonable results /17/. The frequency dependence of the modal series resistance and inductance can be taken into account in the same way as in symmetric lines, while a rigorous inclusion of the frequency dependence of the transformation matrices is still in the development stage.

4.2 Cables

For cables in principle the same applies as for overhead lines. However, short cables within a system may be simulated as lumped capacitances since in relation to overhead lines their capacitance is much higher but their inductance and resistance lower. A cable may be considered as "short" in this respect, if its travelling time is lower than about 30 % of the time constant of the main voltage rise time in such a system.

Long cables may present difficulties in the representation both on TNA's and on digital computer programs if frequency dependent parameters have to be taken into account within a wide frequency band. The basic assumption that the modal transformation matrix is constant, doesn't hold for Group I and II transients. Therefore sometimes a π -element representation with additional parallel damping of the impedances is used also for digital computer simulations. For Group III and IV transients the transformation matrix is usually considered as a

constant. However care has to be taken to ensure proper initial conditions.

4.3 Substations

An overview on modelling methods and on requirements for the representation of specific parts is shown in Table 4. For switching overvoltage studies (Group II) the total capacitance of substations is represented by a lumped capacitance, if necessary. Whereas for lightning overvoltage (Group III) and very fast transients (Group IV) studies the bus ducts are generally represented in detail by means of lossless transmission lines. When simulating very fast transients in GIS caused by restrike phenomena all additional lumped capacitances C (e.g. of measuring transformers) in extreme cases even the spacers and additional inductivities L (e.g. of current transformers), must be taken into consideration. Also elbows may have to be represented taking into account the different travel times of surges inside and outside the elbow. Specific studies in this field have been made by CIGRE WG 33/13.09 /18/.

4.4 Transformers

An exact representation of transformers is very complex. Therefore particular care has to be taken to adjust the representation as well as possible to the requirements of the specific case to be investigated. By that reason their modelling usually will be splitted up in cases where surge transfer from one winding to another is not of interest (e.g. unloaded transformers) and on the other hand, where surge transfer to other windings has to be taken into account. For the most simple example of a single-phase two-winding transformer Table 5 shows an overview on representation methods and the influence of relevant parameters. The transformers are modeled on TNA's and on digital computer programs by a network of resistors, inductances, ideal transformers, saturable inductors and capacitances. If saturation phenomena are to be represented (Groups I and II) the saturable elements have to be inserted as near as possible to

Table 4: Representation of substations

Substations	Group I 0.1 Hz ÷ 3 kHz	Group II 50/60Hz ÷ 20 kHz	Group III 10 kHz ÷ 3 MHz	Group IV 100 kHz ÷ 50 MHz
Representation	negligible			
Instrument transformers	capacitance	negligible	important if $C > 10$ nF	important if $C > 0,5$ nF
	inductance	negligible	negligible	important if $L > 0,1$ μH
	saturation	important, if no power transformers in parallel	negligible	negligible
Elbow	negligible	negligible	negligible	important surge impedances of different travel times
Connecting lines to surge arresters	negligible	negligible	very important	very important
Earth connections	negligible	negligible	important	very important

C = capacitance; Z = surge impedance; τ = travel time

the winding(s) close to the magnetic core (mostly the low voltage winding). At higher frequencies also the capacitances become important (Groups II to IV). If surge transfer is not of interest and if the impedance $Z = Z(f)$ versus frequency f has been measured at the terminals of an actual transformer, for Group III transients it can be modelled by a combination of several damped series resonance circuits connected in parallel to its main inductance and surge capacitance (Fig. 5). This equivalent circuit represents the impedance at the transformer terminals. It does not give a direct information on the voltage distribution inside the transformer but it gives an indication on the relative magnitude of possible internal resonances. For Group IV the surge capacitance C_S^* is of primary interest. It may be paralleled by an ohmic resistance Z_S equal to the equivalent surge impedance of the windings. The addition of Z_S is justified in particular when the transformer turns ratio is in the range of 0.5 to 1.0 which often applies to transformers in HVDC-stations. In specific cases also a representation similar to that proposed for Group III, but valid for higher frequencies may be applied /18/.

4.4.1 More accurate transformer representation

A more accurate representation of single-phase transformers even with three windings is relatively simple. Fig. 6 shows an example of a TNA representation but - based on proper conversion methods - also models using less mutual inductances are possible. The negative resistances ($-R_H, -R_T$) (realized by an electronic device) are used, when necessary, to compensate for the DC resistance of the model. For three-phase transformers, however, the representation is more complicated. A first approximation may be for TNA's the addition of extra delta-connected windings to a bank consisting of three single-phase units, to model the coupling of the three legs. For digital representations, resistance and inductance (or inverse inductance) matrices can be used which represent

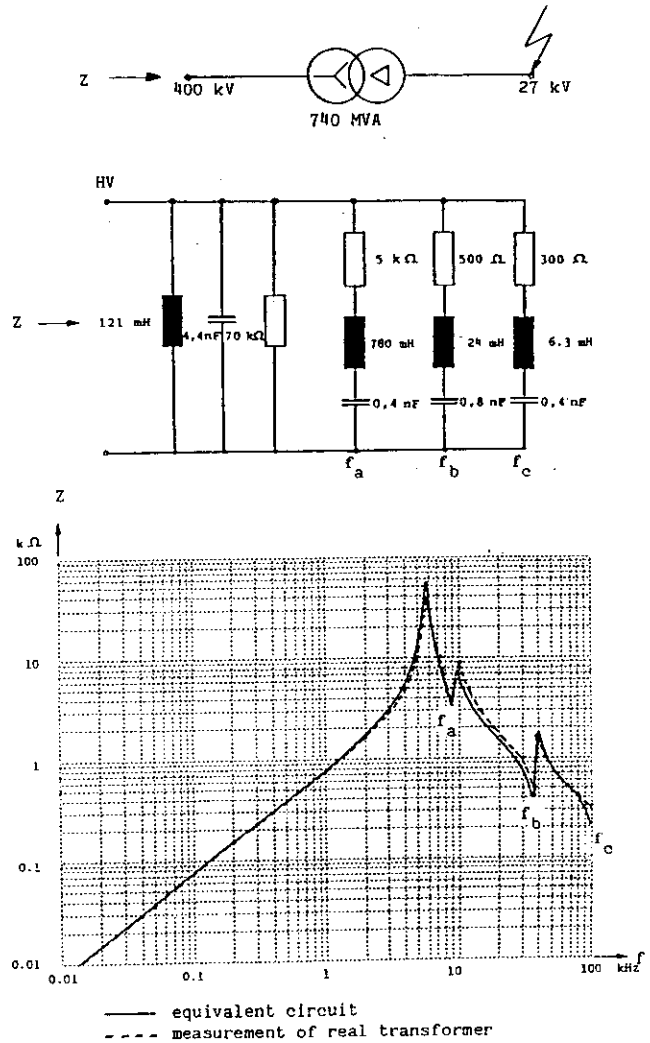

Fig. 5: Equivalent circuit and impedance versus frequency $Z = Z(f)$ of a 740 MVA generator transformer short circuited at its low voltage side

Table 5: Representation of transformers (Stray capacitance to ground not shown)

Transformers	Group I 0.1 Hz ÷ 3 kHz	Group II 50/60 Hz ÷ 20 kHz	Group III 10 kHz ÷ 3 MHz	Group IV 100 kHz ÷ 50 MHz
Without surge transfer 1)				
With surge transfer 1)				
Short circuit impedance	very important	very important	important only for surge transfer	negligible
Saturation	very important	very important for transformer energizing and load rejection with high voltage increase, otherwise negligible (see section 4.4.2)	negligible	negligible
Frequency dependent series losses	very important	important	negligible	negligible
Hysteresis and iron losses	important only for resonance phenomena	important only for transformer energizing	negligible	negligible
Capacitive coupling	negligible	important only for surge transfer	very important for surge transfer	very important for surge transfer

1) Examples for single-phase, two-winding transformers (index 1: outer winding, index 2: inner winding, turn ratio w1:w2)

L = inductance
 R = ohmic resistance
 C = capacitance
 f = frequency
 Lm = magnetizing inductance
 ψ = flux
 RFe = replication of hysteresis and iron losses
 Z = impedance measured at terminals
 Cs = surge capacitance
 Zs = surge impedance of winding
 values indicated by * are lower than the corresponding values without *

these couplings, and whose elements can be calculated from the positive and zero sequence short circuit tests data /19/.

If the internal design of a transformer is known, particularly for frequency Groups I and II, more detailed models can be derived by application of the analogy between magnetic and electric networks taking into account the arrangement of the windings, too /20, 21/. Its principle may be explained by the example of a single-phase three-winding transformer with the high-voltage winding HV and two low-voltage windings LV1 and LV2 (Fig. 7):

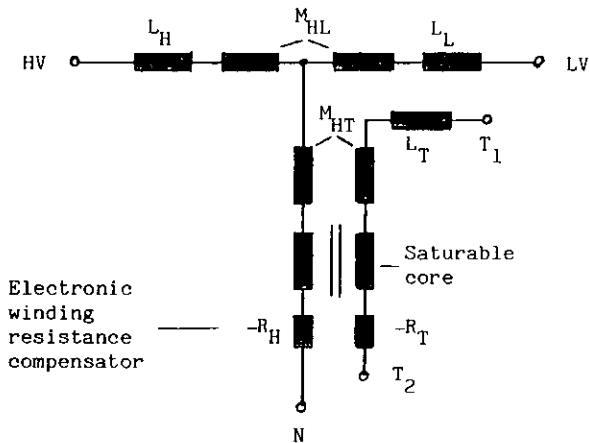

Fig. 6: Example of a TNA representation of a three winding single phase transformer

The equivalent magnetic circuit contains the magnetic permeance of the main magnetic path and the leakage paths (full lines in Fig. 7a). For each winding a magnetic source I is effective. The equivalent electric circuit (dashed lines in Fig. 7a) is in duality to the magnetic circuit. The resulting equivalent electric circuit is shown in Fig. 7b.

In this example the arrangement of the two windings LV1 and LV2 was assumed symmetrical to the high voltage winding (arrangement LV1/LV2 - HV). Therefore the main reactance of the transformer is divided into two equal parts. But this equivalent circuit would change completely in the case, where the three windings are arranged in another way, e.g. the LV1-winding close to the core and the LV2-winding between HV-winding and LV1-winding (arrangement LV1 - LV2 - HV).

To keep the galvanic separation of the circuits, ideal transformers taking into account the relevant turn ratios are required. These ideal transformers partly can be left out by voltage level conversion.

Fig. 8 shows an application of this method on the representation of a two-winding, five-leg three-phase transformer.

For higher frequency ranges additionally capacitances should be added to the R-L-models. As suggested in /22/ they should be included at locations as follows:

- a) between the core and the winding closest to it
- b) between any two windings
- c) between outer winding and tank
- d) across each winding from one end to the other

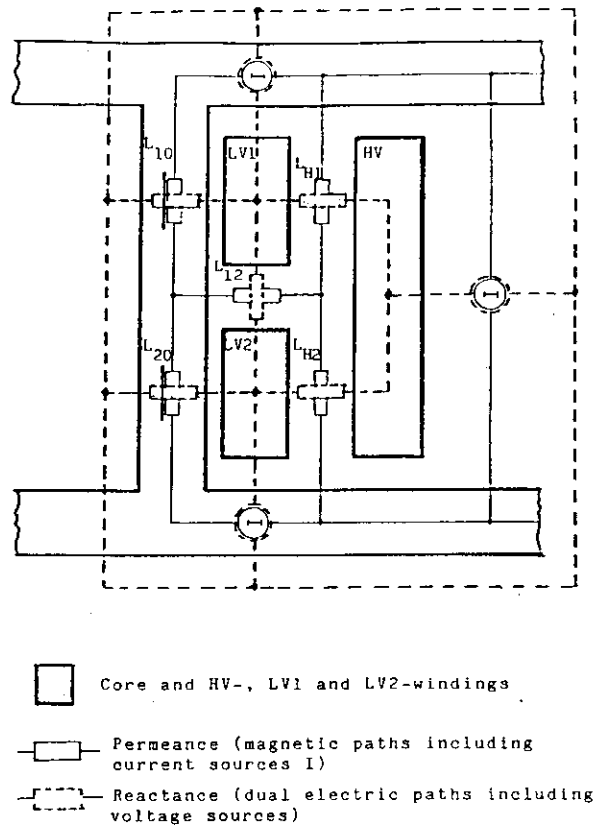

a) Derivation of equivalent electric circuit

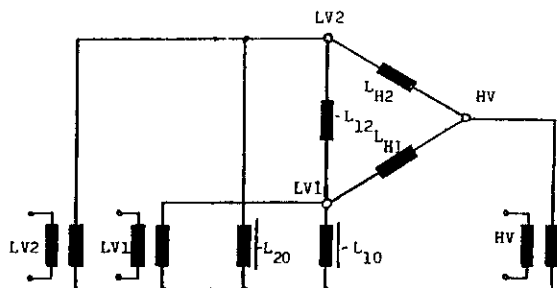

b) Resulting equivalent circuit

Fig. 7: Equivalent electric circuit of a three winding transformer

Reasonably accurate results can be obtained by lumping one half of the capacitance at each end of the winding for locations a) to c) and by lumping the total capacitance in parallel with the winding for location d) as indicated in Fig. 8b.

At very high frequencies, the windings have to be subdivided into several parts (see Fig. 9). By this method also different winding arrangements (disc or cylindrical coils) can be represented accurately /23/.

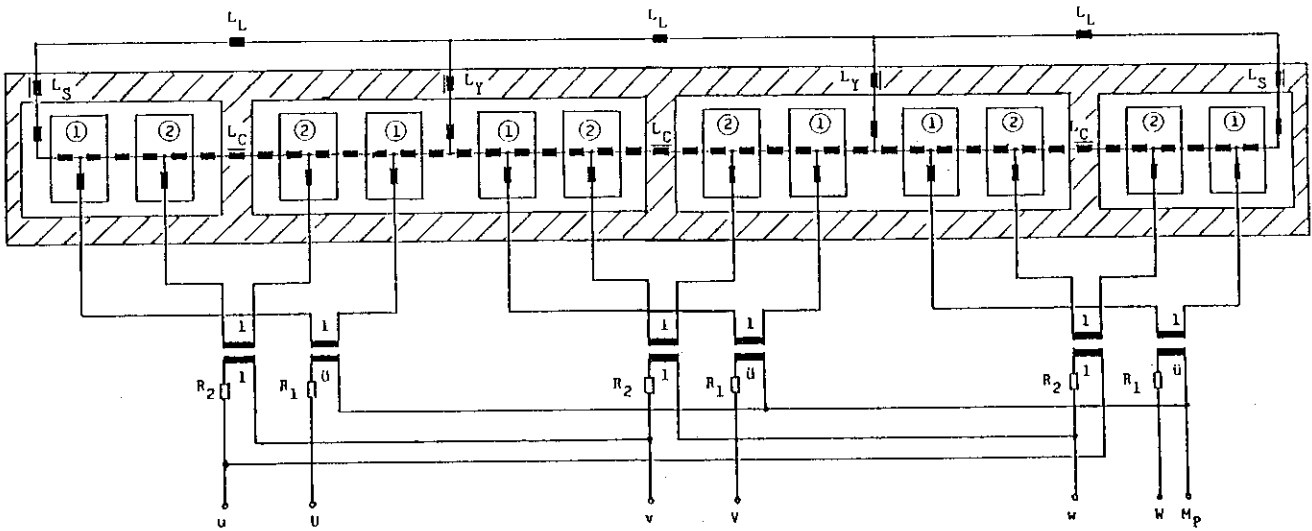
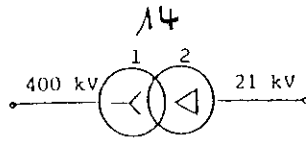

a) Total representation (without capacitances)

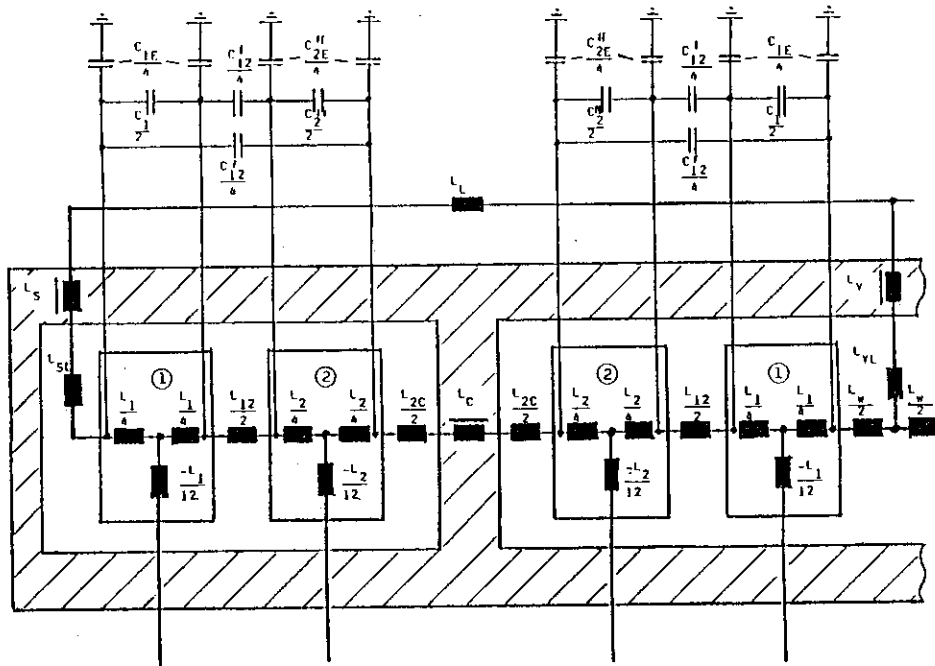

b) Detail (single phase, capacitances included)

Inductances:

- L_1 area of winding 1 (400 kV)
- L_2 area of winding 2 (21 kV)
- L_{12} area between winding 1 and 2
- L_{1C} area between winding 1 and core
- L_Y area between windings 1 of different phases
- L_{SL} area between winding 1 and shell
- L_{YL} area between winding 1 and yoke
- L_L leakage inductance between core and transformer housing

Saturable Inductances:

- L_C core
- L_Y yoke
- L_S magnetic return path (shell)

Capacitances:

- C_{1E} winding 1 to earth
 - C_{2E} winding 2 to earth
 - C_{12} winding 1 to winding 2
 - C_1 parallel to winding 1
 - C_2 parallel to winding 2
- $$C_{2E}^* = C_{2E} \cdot \frac{1}{u}$$
- $$C_{12}^* = C_{12} \cdot (1 - \frac{1}{u})$$
- $$C_2^* = C_2 \cdot \frac{1}{u}$$

Resistances:

- R_1 winding 1 (400 kV)
- R_2 winding 2 (21 kV)

Turn ratio:

$$u = \frac{21}{\frac{400}{\sqrt{3}}}$$

Fig. 8: Representation of a two-winding, five-leg three phase transformer

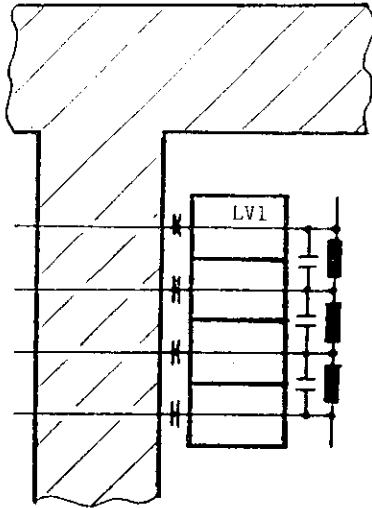

a) Subdivision of a single winding

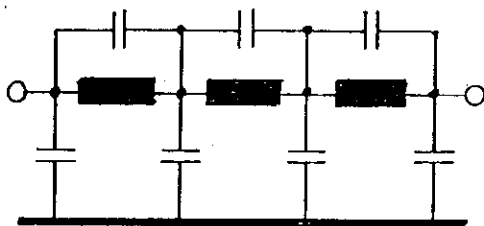

b) High frequency equivalent circuit of a winding

Fig. 9: Equivalent circuit of a winding for very high frequencies

4.4.2 Representation of saturation effects

Representation of transformer saturation is necessary for frequency ranges Group I and II, if transformer energizing will be studied or in cases where a considerable increase of power frequency voltage may occur (e.g. load rejection or switching-on of long unloaded lines or cables).

In cases of transformer energizing not only the saturation characteristic of the switched transformer is important but also that of transformers already energized if they are connected to the same busbar on the feeding side. This requirement is caused by the fact that during flow of the inrush current the switched transformer acts as a source of direct and harmonic currents which may cause saturation effects also in already energized transformers which are located nearby [24].

In cases of load rejection usually only a voltage increase of more than about 20 % above normal operating voltage causes saturation effects in transformers. Therefore in such cases saturation characteristics have to be taken into account only for those transformers which may be stressed by such a high power frequency voltage increase. This may occur particularly in systems with relatively weak sources. It should be mentioned, however, that transformers equipped with tap-changers may be saturated also by a lower power frequency voltage depending on their tap-changer position.

The exact representation of saturation characteristics mostly is restricted by a lack of knowledge

of the actual parameters of the transformers particularly if differences in saturation of cores, yokes and joints should be regarded. A relatively good approximation can be obtained using the inductivity L_s of the transformer windings without the iron core^s (air-cored coil) to obtain the asymptotic slope of the magnetization curve (total flux versus peak current i) in the saturated range. The inductivity L_s depends on transformer design and location of^s the relevant winding with respect to the core. For approximative calculations values of L_s can be assumed as follows referred to the short-circuit inductivity L_k of the transformer:

step-down transformer
(outer winding) $L_s \approx 2$ to $2.5 L_k$

step-up transformer
(inner winding) $L_s \approx 1$ to $1.5 L_k$

autotransformer
(high voltage side) $L_s \approx 4$ to $5 L_k$

As mentioned above saturation characteristics of transformers can be represented by insertion of single-phase saturable elements at specific locations of the equivalent circuit. On TNA's mostly solutions are used as follows:

a) Coils with the same core material as the corresponding transformer. By these the real saturation characteristic can be approximated very well even at higher frequencies. On the other hand that method doesn't allow to change the characteristic to other core materials. The coils of the model indeed have a lower quality factor (higher damping) as the leakage reactance of the real transformer, but in most cases that will be negligible because of the low quality factor of 1 to 4 of the iron losses of a real transformer. On the other hand compensation of the DC resistance of the model by a negative resistance is often necessary for the proper modelling of the decay of inrush currents.

b) Coils with a sharp saturation knee combined with external linear inductances to adjust the actual flux Ψ versus peak current \hat{i} curve as shown in Fig. 10a. The special core material of $L(\Psi)$ allows a very high inductance in the unsaturated area and an extremely low differential inductance in the saturated area. The required voltage current-characteristic at power frequency can be adjusted by the parallel linear inductance L in the unsaturated part and by the series connected linear inductance L_r in the saturated region. By this method the representation can be easily adjusted to the required saturation curve even for different saturation characteristics. But the special core material used for that may have another behaviour at higher frequencies than the real saturable element.

In digital computer programs, the saturable element is usually modelled with a piecewise linear representation which can be implemented with a branch with an inductance L_{mo} equal to the magnetizing inductance in the unsaturated region, paralleled by one or more branches with switched inductances to approximate the flux Ψ versus peak current \hat{i} curve by two or more linear segments (see Fig. 10b). The equation for switched inductance L_j is $\Psi = \Psi_r + L_j i_j$ and not $\Psi = L_j i_j$. The step size Δt must be sufficiently small^j to prevent too large changes along the Ψ/\hat{i} -characteristic. To simulate hysteresis

and eddy current effects, a linear or nonlinear resistance R_{Fe} can be put in parallel to the nonlinear inductance, as shown in Table 5 /25/. Some programs also have nonlinear inductance models with built-in hysteresis effects. To overcome possible problems with numerical instabilities in this respect and to increase the accuracy of such calculations, it also has been proposed to use a complete analytical function for the representation of saturable elements /26/ instead of a piecewise linear function. In TNA representations, hysteresis and eddy current effects are included inherently.

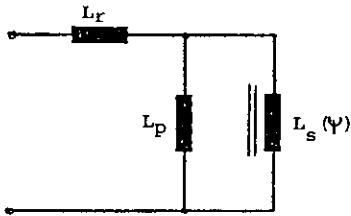
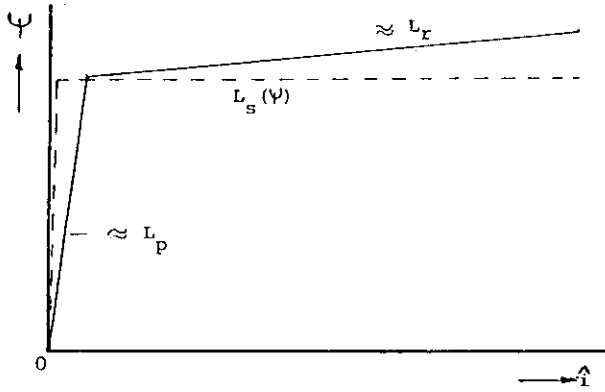

a) TNA representation using special core material

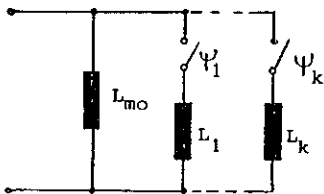
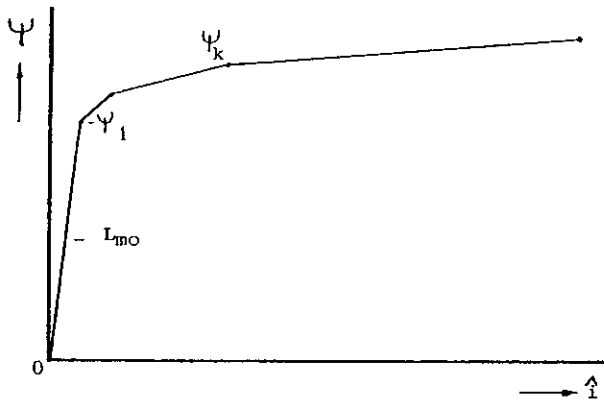

b) Digital computer program representation

Fig. 10: Representation of saturable elements

For specific transformer energizing studies it also is necessary to take into account remanence effects. On TNA's the residual flux must be controlled in order to ensure reproducible results. For digital calculations it is relatively easy to start from a known residual flux. But to calculate the residual flux from a simulation is a problem not solved satisfactorily until today.

4.4.3 Frequency dependent parameters

As shown in Table 5 frequency dependent transformer series losses may have a great influence particularly on Group I oscillations and partly on Group II transients, too. For TNA simulations it is necessary to design the relevant components in order to limit the losses especially at very low and at high frequencies. In digital computer programs the frequency dependence of series resistances $R(f)$ has to be modelled separately. It can be done by equivalent circuits as shown in Fig. 11. The equivalent circuits with increasing frequencies imply a reduction of the leakage inductances L of the transformer with increasing frequencies but such reductions have been also noticed experimentally and explained theoretically on actual transformers /27, 28/. In most cases $k = 2$ (i.e. only two parallel R-L-circuits) gives satisfying results. These equivalent circuits are quite similar to that already proposed in Fig. 1, for the frequency dependent ground return simulation of transmission lines on TNA's.

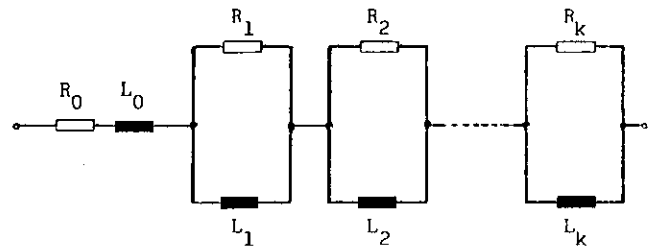

$$R(f) = R_0 + \sum_{i=1}^k \frac{\omega^2 \cdot L_i^2}{R_i^2 + (\omega L_i)^2} R_i$$

$$L(f) = L_0 + \sum_{i=1}^k \frac{R_i^2}{R_i^2 + (\omega L_i)^2} L_i$$

$$\omega = 2\pi f$$

Fig. 11: Equivalent circuit for the simulation of frequency dependent leakage impedance

4.5 Shunt reactors

Reactors can be represented similarly to transformers without surge transfer taking into account, that there is only a single inductance instead of leakage and magnetizing inductances of a transfor-

mer. The rules for modelling saturation effects and frequency dependent losses are the same. When representing a reclosing operation on a shunt compensated line modelling of shunt reactor losses is critical. On TNA's loss compensators are adopted /1/.

Consideration should be given to the fact, that for three-phase reactors the zero sequence impedance generally is lower than their positive sequence impedance.

4.6 Generators

An overview of representation methods and the influence of relevant parameters is shown in Table 6. Very detailed models are necessary for Group I. They are based on the generator equations, on TNA's /29/ as well as on digital computer programs /6/. The representations for Group II to IV transients are quite similar to those for transformers without surge transfer. The representations proposed in Table 6 for Groups III and IV, however, are required only if transients on the generator-side of the generator-transformer are investigated. The impedance applicable for these transients is the subtransient impedance. The frequency dependence of subtransient inductance and losses has to be considered partly for Group II transients. For mainly single frequency transients the values valid for that frequency can be used, for transients including a wider frequency range frequency dependent representations according to Fig. 11 should be applied.

4.7 Surge arresters

An overview on parameters to be taken into account for replication of conventional SiC arresters with gaps and of gapless metal oxide arresters is shown in Table 7.

On TNA's the residual voltage characteristic of conventional surge arresters is modeled by varistors and that of metal oxide arresters by varistors as well as by Zener diodes in combination with lumped resistors in series and in parallel to adjust the characteristic of the actual arrester. The sparkover voltage of conventional surge arresters can be realized by a voltage controlled switch /1/.

On digital programs the residual voltage characteristic is modelled by piecewise linear slopes or by analytical functions.

Similar to the case mentioned in section 4.2.2 also for these representation the time step Δt must be chosen sufficiently small to prevent too large changes along the u/i-characteristic. For Group III and IV transients the sparkover voltage $u_{as}(t)$ versus time of conventional surge arresters can be characterized according to /30/ by a voltage U_{∞} (lower limit of sparkover voltage) and a voltage-time area F (area above U_{∞} until sparkover) and included in the computer program as sparkover criterion. The values of U_{∞} and F can be derived from the sparkover-voltage versus time curve $u_{as}(t)$ of the actual arrester as shown in Fig. 12.

For very high frequency transients (particularly Group IV, partly Group III, too) the inductances L_c of the connecting lines to earth and for metal oxide surge arresters also the inherent inductances L_a of the arrester itself have to be taken into account. Average values for these inductances are 0.5 to 1 μH per m connecting line length resp. arrester height.

For very steep front surges also the earth grid may be represented (see section 4.13).

Table 6: Representation of generators

Generators	Group I 0.1 Hz + 3 kHz	Group II 50/60 Hz + 20 kHz	Group III 10 kHz + 3 MHz	Group IV 100 kHz + 50 MHz
Representation	Generator equations simulation of performance in direct (d) and quadrature (q) axis saturation excitation mechanical torque			
Transition from subtransient to transient and to synchronous impedance	very important if close to location of switching event	important only for decay of short circuit current otherwise negligible	negligible	negligible
Voltage control	very important	negligible	negligible	negligible
Speed control	important	negligible	negligible	negligible
Frequency dependent parameters	very important	important	negligible	negligible
Capacitances	negligible	important	very important	very important

*) Representation required only if transients on the generator-side are investigated







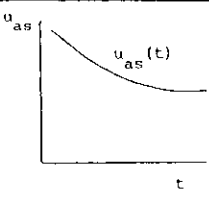
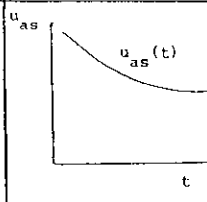
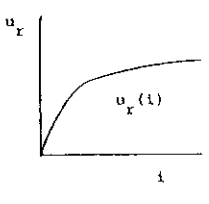
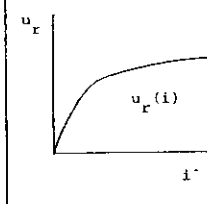
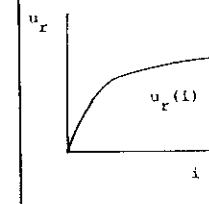
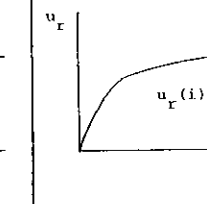
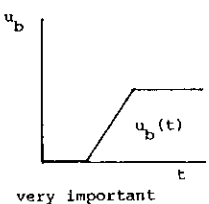
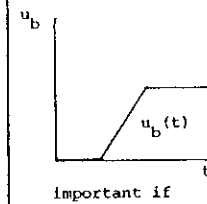

L = inductance
R = ohmic resistance
C = capacitance
f = frequency

L' = subtransient inductance
E = electromotoric force

Ca = surge capacitance
Z = impedance measured at terminals

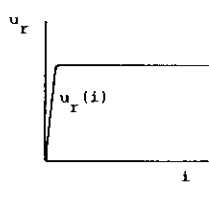
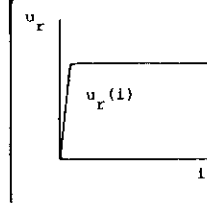
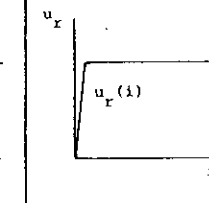
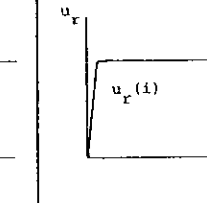
values indicated by * are lower than the corresponding values without *

Table 7: Representation of surge arresters

Surge arresters	Group I 0.1 Hz ÷ 3 kHz	Group II 50/60 Hz ÷ 20 kHz	Group III 10 kHz ÷ 3 MHz	Group IV 100 kHz ÷ 50 MHz
Conventional (SiC)  Sparkover voltage	constant value power frequency sparkover voltage U_{apf}	constant value switching impulse sparkover voltage U_{ai}		
Residual voltage $u_r(i) + u_b(t)$ characteristic of non-linear SiC resistors $u_r(i)$				
arc voltage of active gap $u_b(i)$	 very important if active gap	 important if active gap	negligible	negligible
Current extinction	very important	important	negligible	negligible
Inductance L_c of connecting line to earth	negligible	negligible	important 	very important 
Metal oxide (ZNO)  Residual voltage characteristic $u_r(i)$				
Variation of residual voltage characteristic $u_r(i)$ with temperature	important for evaluation of absorbed energy	negligible	negligible	negligible
Inherent inductance L_a	negligible	negligible	important 	very important 
Inductance L_c of connecting line to earth	negligible	negligible	important 	very important 

i = current
t = time

4.8 Instrument transformers

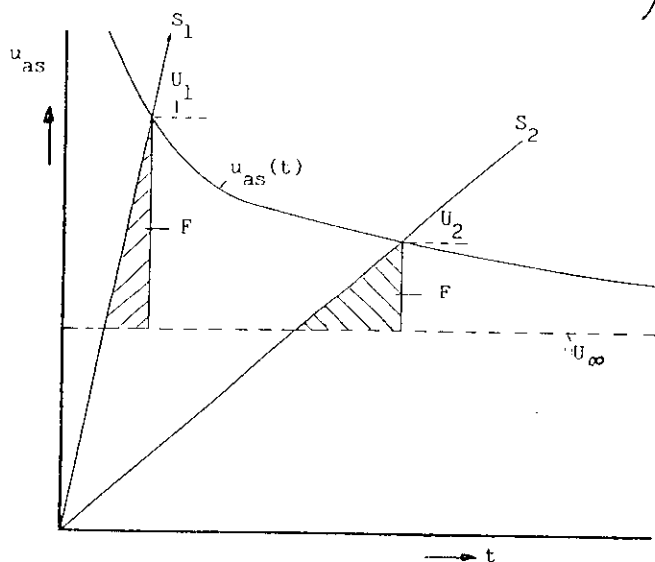

Instrument transformers can be neglected in almost all studies. Only in case of trapped charges (Group I) the saturation characteristic of inductive voltage transformers has an influence if there are no power transformers or reactors connected in parallel. For very high frequency transients the surge capacitances C_s and partly the inductance of current transformers S are of interest. For current transformers and inductive voltage transformers the capacitance C_s is about 500 pF whereas it is some 1000 pF for capacitive voltage transformers. Therefore the latter may have an influence on Group III transients, too. For capacitive voltage transformers in Group IV also the connecting line to the conductor has to be considered.

An overview on representation methods and influence of parameters shows Table 8. In principle the saturation characteristics can be replicated as shown in section 4.4. Also if voltage transfer is of interest, similar representation methods can be applied as for transformers.

4.9 Thyristor valves

An overview on representation methods and influence of relevant parameters is shown in Table 9. On TNA's special thyristors are used with low on-state voltage. But even this low on-state voltage has to be compensated by specially designed operational amplifiers [7]. To prevent uncontrolled transients of higher frequencies also in Group I the snubber circuit has to be represented. For digital simulations of Group I and II transients it has to be taken into account that programs using fixed values of time step Δt (see section 6.2) require values of $\Delta t \leq 100 \mu s$ to reduce errors in fixing instants to less than 1° el. Otherwise the content of harmonics would be increased. In Group III and IV thyristors normally are considered only in on-state

$$U_\infty = U_2 \cdot \frac{\frac{U_1}{U_2} \cdot \sqrt{\frac{S_2}{S_1}} - 1}{\sqrt{\frac{S_2}{S_1}} - 1}$$

$$U_1 = U_\infty + \sqrt{2 S_1 \cdot F}$$

$$U_2 = U_\infty + \sqrt{2 S_2 \cdot F}$$

$$F = \frac{1}{2} \cdot \frac{(U_1 - U_\infty)^2}{S_1}$$

S = voltage steepness

Fig. 12: Evaluation of U_∞ and F from sparkover-voltage versus time characteristic $u_{as}(t)$ for times to sparkover between 0.1 and 10 μs according to [30]

Table 8: Representation of instrument transformers

Instrument transformers 	Group I 0.1 Hz ÷ 3 kHz	Group II 50/60 Hz ÷ 20 kHz	Group III 10 kHz ÷ 3 MHz	Group IV 100 kHz ÷ 50 MHz
Representation 	 inductive voltage transformer	negligible	 capacitive voltage transformer	 voltage transformer current transformer
Saturation	important in case of trapped charges if no transformers or reactors in parallel	negligible	negligible	negligible
Capacitances	negligible	negligible	important especially for capacitive voltage transformers	very important
Inductance of current transformers	negligible	negligible	negligible	important for very high frequencies

R = resistance; L = inductance; Ψ = Flux; C_s = surge capacitance

Table 9: Representation of thyristor valves

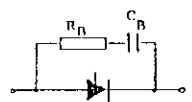
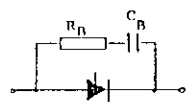
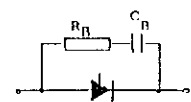
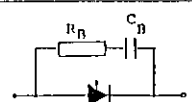
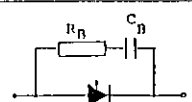
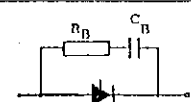
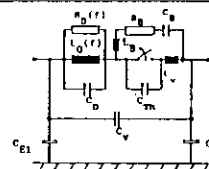
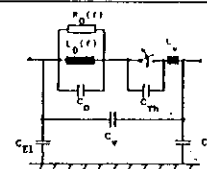
Thyristor valves 	Group I 0.1 Hz ÷ 3 kHz	Group II 50/60 Hz ÷ 20 kHz	Group III 10 kHz ÷ 3 MHz	Group IV 100 kHz ÷ 50 MHz
TNA representation 	 On-state voltage compensation	 On-state voltage compensation	not used	not used
Digital computer representation 				
Firing pulses on thyristors	very important	important	negligible (only on-state/off-state)	negligible (only on-state/off-state)
Snubber circuit R_B, C_B	important	very important	important (inductance L_B included)	negligible
Valve reactor inductance L_D paralleled by resistance R_D	negligible	negligible	very important	very important
Stray capacitances $C_D; C_{Th}; C_V; C_E$	negligible	negligible	very important	very important
Valve circuit inductance L_V	negligible	negligible	important	important

or off-state conditions. If the internal stresses associated with the commutation process in the valve are of interest, the assumption of an ideal switch is not adequate and a more sophisticated model is required. Also it has to be taken into account that the inductance value L_D of iron core valve reactors changes between off-state (unsaturated) and on-state conditions (saturated). Moreover for these Group III and IV transients L_D has to be paralleled by a resistance R_D since at high frequencies the iron losses have to be considered. Both values are frequency dependent. Their quality factor may reach $L_D/R_D = 1$. Also the stray capacitances to earth and the valve conductor inductance L_V have to be taken into account.

For Group IV transients the internal inductances L_B of the snubber circuit resistance R_B suppresses the influence of the snubber circuit.

4.10 Circuit breakers and disconnectors

Parameters which may be of interest for the replication of circuit breakers or disconnectors during closing and opening operations are compiled in Table 10. On TNA's special bounce-free relays or semiconductor switches with voltage drop compensation are used for the representation whereas on digital computer programs the basis is an ideal switch with controlled operation. During closing operations the mechanical pole spread (less than 5 ms due to the standards) and prestrikes may have an influence /31/. For statistical studies on closing operations it should be taken into account, that the mechanical pole spread of a specific circuit breaker may be smaller and not gaussian distributed as normally assumed for more general statistical studies.

For multi-unit circuit-breakers the dispersion of insertion times in each unit results in a considerable reduction of overvoltages compared with the case of a circuit-breaker represented by only one chamber /31/.

If a circuit breaker is provided with a closing resistor it has to be simulated in any case.



Opening operations in the low frequency range (Group I) are influenced by the arc-conditions. By digital computer programs they can be modelled in different ways. One method is to represent the actual arc voltage $u_a(i,t)$ by multiplying the voltage-current characteristic $u_a(i)$ of the arc with a weighting function $c(t)$,^a representing the arc behaviour versus time under the influence of blast pressure, arc length and arcing time as evaluated from circuit breaker tests /32/. Also arc equations based on black-box models or physical models can be applied /33/. (see Fig.13)

Chopping effects during interruption of small inductive currents are dealt with by CIGRE WG 13.02 (Interruption of small inductive currents) /34/.

For opening operations in the high frequency range the breaker characteristics with respect to restrikes (withstand voltage versus time between contacts during opening) and the capability to interrupt high frequency transient currents have to be taken into account (see Fig. 14).

For fast transients in GIS (Group IV) the time of development of the discharge across the contacts has an influence in limiting the steepness of the fronts /35/. Therefore the spark has to be represented by a time-varying resistor /18/.

Table 10 : Representation of circuit breakers and disconnectors

Circuit breakers, disconnectors 	Group I 0.1 Hz ± 3 kHz	Group II 50/60 Hz ± 20 kHz	Group III 10 kHz ± 3 MHz	Group IV 100 kHz ± 50 MHz
Closing  mechanical pole spread	important	very important	negligible	negligible
Prestrikes (decrease of spark-over voltage versus time)	negligible	important	important	very important
Opening 				
High current interruption (arc equations)	important only for interruption capability studies	important only for interruption capability studies	negligible	negligible
Current chopping (arc instability)	negligible	important only for interruption of small inductive currents	important only for interruption of small inductive currents	negligible
Restrike characteristic (increase of spark-over voltage versus time)	negligible	important only for interruption of small inductive currents	very important	very important
High frequency current interruption	negligible	important only for interruption of small inductive currents	very important	very important

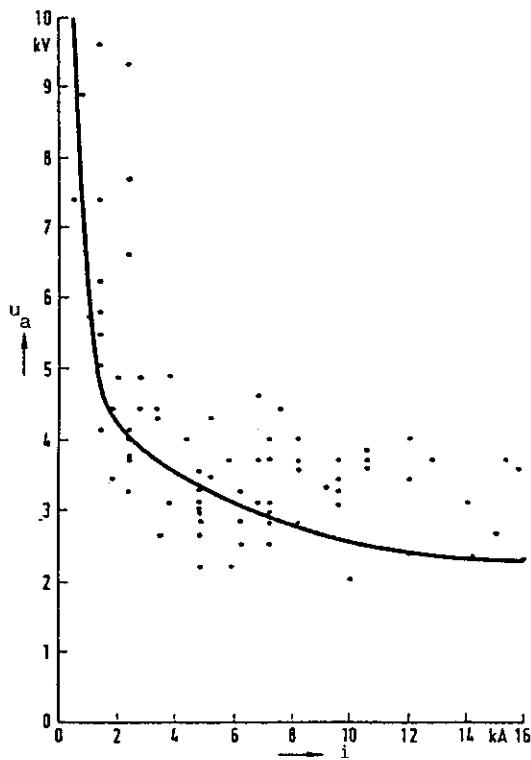

a) Voltage-current characteristic $u_a(i)$

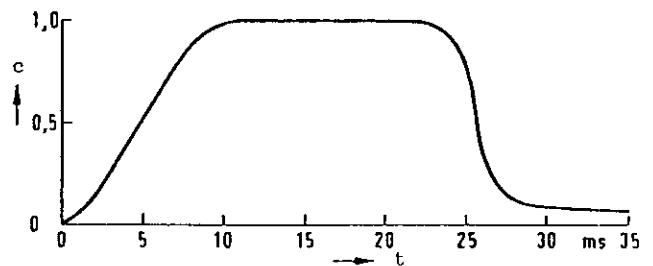

b) Weighting function $c(t)$

Fig. 13: Representation of actual arc voltage /32/
 $u_a(i,t) = u_a(i) \cdot c(t)$

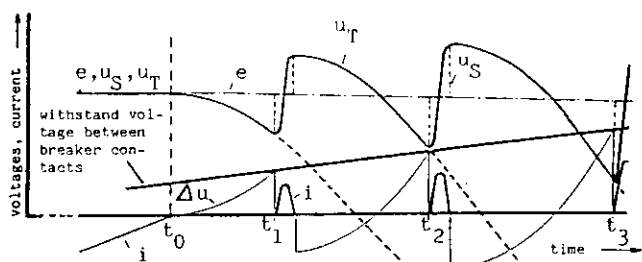
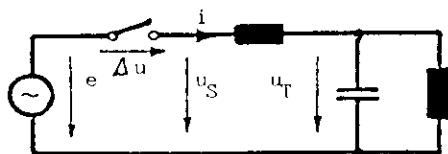

t_0 = instant of power frequency current interruption
 $t_1 \dots t_3$ = instant of 1st...3rd reignition

Fig. 14: Multiple reignitions during interruption of inductive currents

4.11 Insulation flashover

Lightning overvoltages (Group III) are to a great extent determined by possible flashovers of the line insulation. Consequently, a suitable model is needed to calculate flashover voltage as well as time to flashover for non standard impulses. Particularly in studies of backflashover (possible consequence of strokes to towers and shield wires) irregular voltage impulses must be dealt with. CIGRE WG 33.01 (Lightning) is studying these problems in detail.

The relevant models can be divided into voltage integration and discharge development models.

Voltage integration models considers the integral

$$f(t) = \int [u(t) - U_{\infty}]^n dt$$

where

$u(t)$ = applied voltage
 U_{∞} = threshold voltage
 n = exponent ($n \geq 1$)

Flashover is assumed to occur when the integral reaches a limit value $f(t) = F$. The parameters U_{∞} , n and F are empirical values, based on observed relations between flashover voltage and time to flashover for different gaps and impulses tested in the laboratory. In the "constant area method" /30/ the parameter n is equal to one. (See also section 4.7, Fig. 12, in which the integration model is applied to determine arrester sparkover). In general, n and F are different for positive and negative polarity. Statistical spread can be included in the parameter F /36/.

The discharge development models assume that a leader starts from the energized electrode when the average gradient in the gap reaches a critical value E_0 . The leader then progresses in the gap with variable velocity. The applied voltage when the leader has crossed the gap is the discharge voltage. A relation is assumed, based on physical observations, between the velocity of the leader

and the other variables of the discharge development, as the unbridged part of the gap, the applied voltage, etc.

For this model the following expression has been found for gaps without essential influence of the insulator /37/:

$$v_1 = 170 d \cdot \left[\frac{u(t)}{x} - E_0 \right] \cdot e^{-0.0015 \frac{u(t)}{d}}$$

where

v_1 = leader velocity in m/s
 d = gap clearance in m
 $u(t)$ = applied voltage in kV
 x = part of the gap still unbridged by the leader in m
 E_0 = average gradient in gap corresponding to the standard lightning impulse 50 % discharge voltage in kV/m

E_0 depends on polarity, of electrode configurations and on gap clearance /37/.

For gaps essentially influenced by insulators no similar general model could be found. At least for the time being, in order to obtain better accuracy, it is suggested to use either voltage integration models, with empirical determination of parameters /36/, or empirical adjustment of discharge development ones.

4.12 Tower and tower footing representation

As pointed out in section 4.1 transmission line tower impedance and tower footing resistance must be included when calculating lightning overvoltages (Group III). The footing resistance is of primary importance, and especially for high towers and steep surges also the tower impedance will have an essential effect.

In such studies the towers are usually represented by a surge impedance including a travel time. In principle, the surge impedance is varying along the tower, but for practical purposes a constant average value is sufficient. Surge impedance and travel time can be calculated from the physical dimensions of the tower /38, 39/. Normally, the surge impedance will be in the range of 100 - 200 ohms.

The tower footing resistance is very much depending on the soil resistivity and the earth electrode arrangement. In principle the footing resistance is frequency and current dependent. The numerical value normally increases with increasing frequency and decreases with increasing current above a critical value. The current dependence is a result of soil ionization /40, 41/.

For earth electrodes of small dimensions (rods etc.) in soil of low resistivity the footing resistance can be represented by a constant value with reasonable accuracy. For counterpoise systems that often must be used in areas of high soil resistivity, however, frequency dependency as well as current dependency ought to be included /41/. For the time being it seems that no agreed method how to combine these dependencies does exist.

4.13 Earthing systems

The comments concerning tower footing resistance models are also valid for earthing systems in general. For substations etc. normally complex

earthing systems (grids) are applied and the effective earthing resistance is rather low.

For Group IV transients (for instance external very fast transients of GIS or faults in the substation) it may be necessary to include a full representation of each part of the earthing system. Also in some other special cases (crossbonded cables, lightning overvoltages in substations of great extension and poor ground conductivity etc.) a detailed modelling of the earthing system may be mandatory. A travelling wave approach in which the electrodes are modeled by line stubs in parallel to a number of leakage resistances is considered to be applicable in such cases /42/.

5. Network equivalents and loads

In some cases detailed modelling of all relevant parts of a system is not possible. Therefore simplified equivalent circuits are used. This refers particularly to parts of extended networks and to complex loads.

5.1 Network equivalents

In general networks consist of several substations interconnected by lines and of infeeds from power plants or from other networks directly or via transformers. A detailed representation of all components will result in large computation times and memory requirements in digital computer calculations whereas in case of analog models a large number of elements is needed. Therefore network reduction is necessary.

With increasing distance from the location in a system which is of interest for a study other parts of the network can be simplified more and more. But the equivalent circuits used for the replication have to offer at their borders the same performance as the real partial networks over the range of frequency which is of interest for the relevant transients. The following characteristics therefore must be regarded for the direct and zero sequence system of these parts of the network:

- power frequency short-circuit impedance
- the most important natural frequencies up to the maximum frequency of interest for the transient
- the damping in the range of the main frequencies to be expected

If particularly for Group I and II transients exact representations are needed the frequency dependent impedance $Z_1(f)$ in the positive and $Z_0(f)$ in the zero sequence system have to be computed by a pre-calculation taking into account all components of the partial networks to be reduced including their frequency dependent losses. For both impedances $Z_1(f)$ and $Z_0(f)$ then Foster equivalent circuits with a series arrangement of parallel RL-RC circuits according to Fig. 15a /43/, or similar circuits /44/, can be synthesized to match the frequency dependent characteristics of $Z_1(f)$ resp. $Z_0(f)$. In general a correct representation of the complex source impedances up to two times the main frequency which is of interest will be adequate.

For normal switching operations (Group II) the detailed model of the system in general must comprehend the part of network up to the second substations behind that of the operating circuit breaker. For line energization and re-energization studies exact representation only up to the first substations is sufficient in most cases. If the partial network to be reduced is connected via a transformer to the part modeled in detail only

its resulting short circuit impedances in the positive and zero sequence system have to be considered, as it has been proposed already in /3/ for TNA's. For other parts of networks equivalent circuits as shown in Fig. 15 can be used. If a smaller part of the whole system is to be reduced a simplified equivalent circuit according to Fig. 15b can be used consisting of the resulting short circuit impedance (L_{SC} , R_{SC}) of the reduced part and the equivalent capacitance C of the reduced part in series with an ohmic resistance R_S equal to the value of the resulting surge impedance of all lines connected to the substation except those which are replicated in detail. Capacitor banks should be added separately. For partial systems with high short circuit power and a total capacitance much higher than the part modeled in detail the circuit according to Fig. 15c can be used.

All circuits shown in Fig. 15 apply both to the positive and the zero sequence equivalents of the relevant network with the obvious difference that for the positive sequence it is necessary to connect the voltage source behind the passive equivalent network.

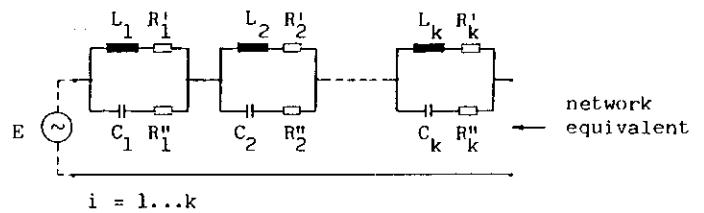

a) Foster equivalent circuit /43/

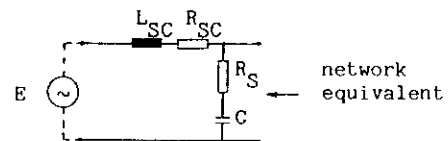

b) Equivalent circuit for smaller partial networks

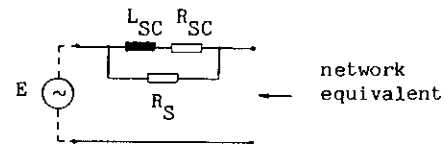

c) Simplified equivalent circuit for partial networks with high short circuit power

Fig. 15: Network equivalent circuits (Examples for positive sequence system)

For Group III and IV transients the method generally adopted is to model the substation in detail whereas outgoing lines are replaced by their surge impedance. If however during the time span of observation of the transient, waves reflected from the far ends contribute to the transients the line and the conditions at the far end must be represented, too (for a time span to be considered of e.g. $t = 10 \mu s$ all reflections within a distance of $a = 1500 m$ have to be taken into account if $v = 300 m/\mu s$).

5.2 Loads

Since loads normally are connected to the systems studied via transformers their influence is

restricted to low frequency ranges, since the inductance of the transformer reduces their effects at higher frequencies. Loads should be taken into account up to frequencies of some kHz (Group I and partly Group II). Based on measurements of the frequency dependence of complex loads in medium voltage systems CIGRE WG 36.05 (Disturbing loads) proposes an equivalent circuit as shown in Fig. 16a for ohmic-inductive loads on the medium voltage side behind the transformer/45/. For motoric loads an impedance and a voltage source have to be taken into account on the medium voltage side (see Fig. 16b). In both cases also the equivalent capacitance C of the medium voltage system is of importance /46/.

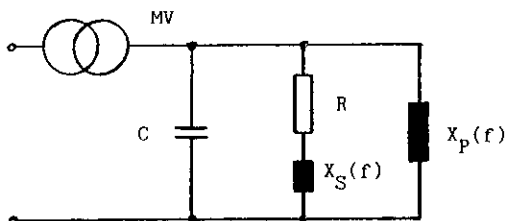

$$R = \frac{U^2}{P} ; X_S = 0.073 \cdot R \cdot f/f_0$$

$$X_P = \frac{R \cdot f/f_0}{6.7 Q/P - 0.74}$$

U = system voltage
f = frequency
C = capacitance of medium voltage system
P = ohmic load
Q = inductive load } at power frequency f_0

a) Ohmic-inductive loads /45/

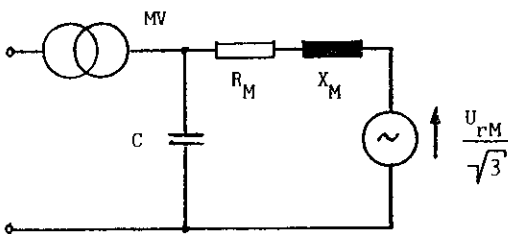

$$Z_M = R_M + jX_M = \frac{1}{J_{LR}/J_{rM}} \cdot \frac{U_{rM}^2}{S_{rM}}$$

U_{rM} = motor rated voltage
 S_{rM} = motor complex power
 J_{rM} = motor rated current
 J_{LR} = symmetrical locked motor current
C = capacitance of medium voltage system

Values for high voltage motors:

$$X_M \approx 0.99 Z_M ; R_M/X_M = 0.10 \text{ to } 0.15$$

$$J_{LR}/J_{rM} = 3 \text{ to } 5$$

b) Motoric loads

Fig. 16: Representation of loads in medium voltage systems (MV)

6. Accuracy

The accuracy of the results obtained depends on the accuracy of representation of the system components as well as on the accuracy of the available input data. Also the type and duration of an oscillation or a transient can be decisive for the achievable overall accuracy. In detail the following aspects may influence the accuracy of a study:

6.1 Accuracy of input data

The main problem of accuracy of results is to get the exact input data.

Frequently these can be determined only approximately particularly in the planning stage of a network or a substation. In such cases a lot of assumptions have to be made according to the experience already gained on the characteristics of similar components. In general this refers to frequency dependent parameters but very often also to basic parameters, particularly in the frequency ranges Group III and IV. More exact data normally are available for frequency ranges Group I and II (except saturation characteristics) and if well defined smaller parts of networks are considered.

System parameters also may change with climatic conditions (e.g. dependence of line sag on temperature) or be dependent on manufacturing and maintenance (e.g. pole spread of circuit breakers).

But the accuracy of the results also depends on the type of overvoltage studies. Fig. 17 shows some generalized examples for the influence of parameter deviations: In case of switching overvoltages mostly the maximum peak of overvoltages is of interest which normally occurs during the first 10 to 20 ms after the switching operation. Larger differences in peak values may result only by strong deviations in loss representation (see Fig. 17a for 1, 2 and 5 times losses at power frequency), whereas deviations in inductances or capacitances of $\pm 10\%$ only lead to a time shifting of the peak but not to remarkable differences in peak values (Fig. 17b). Both figures, however, show clearly that the deviations of oscillations increase with time. If on the other hand resonance phenomena are studied (Group I) even deviations in capacitances of $\pm 10\%$ may lead to totally different results (Fig. 17c), since resonance phenomena need longer time to develop as well as they are very sensitive on matching the exact data.

6.2 Problems of representation

The more separate components a system includes, the higher the possibility of insufficient or wrong modelling is. That may influence the accuracy of a study. Therefore highly skilled and experienced people are necessary to find out failures in representation and to ensure results as correct as possible.

Beyond that, however, specific difficulties may arise for TNA as well as for digital computer representations:

6.2.1 TNA representations

The models of the components for TNA application are mostly limited by the following reasons:

- The representation of extended networks requires an extremely large number of components. This fact can partly be overcome by the use of network equivalents (see section 5), but their rea-

lization by actual inductances, resistances and capacitances is often very complex, in particular, if an extended frequency band is required.

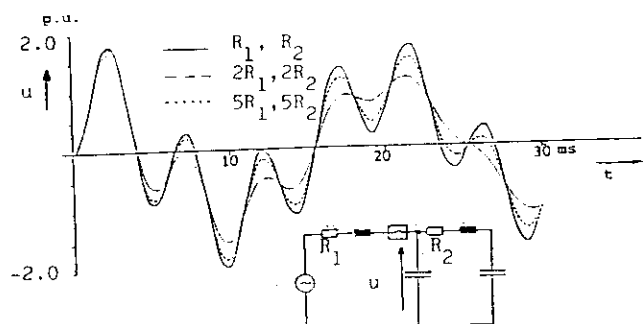

a) Switching overvoltages, variation of damping

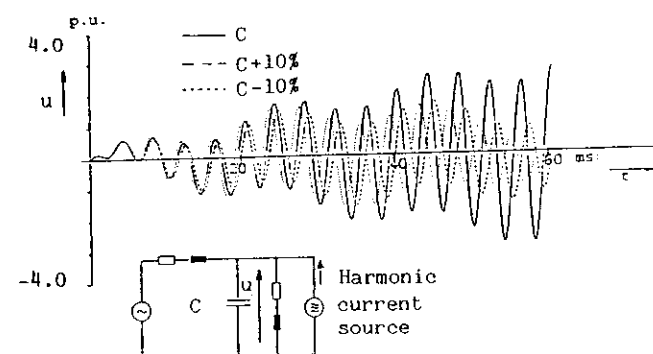
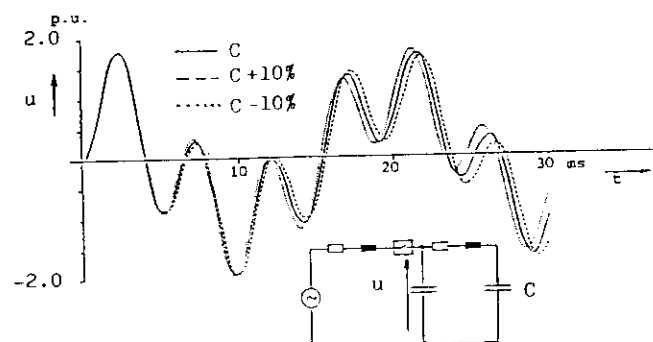

b) Resonance phenomena, variation of capacitances

Fig. 17: Examples for the influence of parameter variations on switching and resonance phenomena

- The model inductances have loss characteristics that match actual network components only within a limited range. The use of electronic loss compensators helps as regards low frequency losses but not at higher frequencies in the range of tens of kHz. In general a careful evaluation is required.

- The replication of lines by a finite number of series connected π -sections may produce spurious oscillations. Also parasitic capacitances and inductances of connections of the elements may introduce incorrect oscillations and unwanted electrostatic or electromagnetic coupling.

- The inaccuracy in setting the proper values of the components may produce undesired unbalances.

6.2.2 Digital computer representations

There are various digital programs in use with different characteristics but in general for digital computer calculations problems may arise as follows:

- The representation of very extended networks as accurate as possible requires very long computation time.

- Except for transmission lines the frequency dependence of losses and inductances in most cases has to be represented by special equivalent circuits. Frequently they are complicated to be handled and of limited application. In general most digital models are inherently under-damped at high frequencies. It is often necessary to add parasitic components (resistors, capacitors and in some cases also inductances) in order to limit the frequency band of the model and to give a reasonable damping at high frequencies.

- In cases of current interruption, the current will not be exactly zero at the time step where the zero crossing has been detected. In specific cases this may cause unreal current chopping effects. Programs using a fixed time step Δt ignore this overshoot, but other programs restart the calculation with re-initialized variables at the current zero found from backward linear interpolation. Therefore programs with fixed time step may need smaller values of Δt for the computation of such cases than others.

- Setting of initial conditions of the networks may be very complex when others than power frequency sources (e.g. sources of harmonics or direct current sources with thyristors) are present. In such cases often a long time of calculation has to be spent before a steady state condition of the network is reached as initial condition. Methods are being developed which superimpose harmonics found from steady-state solutions to get more accurate initial conditions [47].

- This representation guidelines focus on digital programs which are able to model a large variety of transient phenomena with many different network elements. These programs use time domain calculations with either a fixed or a variable time step size, which introduces discretization errors and therefore influences the accuracy. On the other hand there are also frequency domain methods based on Fourier or Laplace transformation. They can model frequency dependence more accurate, but their application usually is restricted to linear networks. Therefore they are only used in special cases.

6.3 Achievable overall accuracy

As comparisons between field tests and TNA- and digital computer studies have shown for Group II transients accuracies of $\pm 5\%$ may be achieved for small and well defined networks, if statistical peak values are considered [3]. Higher tolerances have been reported for more extended networks and single switching operations at the SC33-Colloquium 1981 in Rio de Janeiro, but it is the opinion of the Working Group that these tolerances can be reduced with the improved representation methods available today if the network models are highly skilled and the component characteristics are well known.

As regards Group I overvoltages the problem of matching possible resonance conditions could be

overcome by performing several variants of calculations taking into account possible deviations by changing the relevant parameters of input data. Problems with accuracy still exist with modelling of saturation characteristics since practically no exact data are available on the performance of transformers, reactors and generators in the highly saturated area. Also some problems still exist with the representation of the transformer itself.

For Group III and particularly Group IV transients the accuracy of calculations is not well verified so far. Besides the problems in realizing appropriate field measurements it is difficult to get actual input data to model the complex behaviour of components and substation sections particularly in the range of very high frequencies.

7. Conclusions

The report shows methods of representation of the various network components on TNA's and digital

computer programs. Since models valid for all frequency ranges are not available the methods of representation have been grouped according to four overlapping frequency ranges. Also possibilities to reduce extended networks by using network and load equivalents are presented.

The accuracy of results of such studies is strongly influenced by the accuracy of the input data and the duration of the transient which is of interest but also by the accuracy of the models used for the representation. So far sufficient accuracy can be reached for switching overvoltage studies. Problems still exist with modelling of saturation characteristics and of very steep front surges (mainly fast transients caused by restrike phenomena or faults in GIS), since knowledge of actual input data mostly is insufficient. Further efforts to study these specific problems in more detail in the future are recommended.

8. References

- | | | | |
|-----|--|------|--|
| | | /8/ | H.-J. Köster, K.-H. Weck: Dämpfung von Blitzüberspannungen durch Stoßkorona. (ETZ-Archiv 3 (1981), pp. 419 - 426) |
| /1/ | A. Clerici: Analog and digital simulation for transient overvoltage determinations. (Electra 22 (1972), pp. 111 - 138) | | |
| | | /9/ | T. Ono, H. Matsubara: Number of sections necessary for transmission line model used for transient network analyzer. (Electr. Engineering Japan 95 (1975) 5, pp. 26 - 33) |
| /2/ | WG 13.05: The calculation of switching surges.
I. A comparison of transient network analyzer results. (Electra 19 (1971), pp. 67 - 78) | | |
| | | /10/ | J.G. Kassakian: Effects of non-transposition and frequency dependent neutral modeling on the simulation of power transmission systems. (Massachusetts Institute of Technology, El. Power System Laboratory, Report 41, Sept. 1973) |
| /3/ | WG 13.05: The calculation of switching surges.
II. Network representation for energization and re-energization studies on lines fed by an inductive source. (Electra 32 (1974), pp. 17 - 42) | | |
| /4/ | WG 13.05: The calculation of switching surges.
III. Transmission line representation for energization and re-energization studies with complex feeding networks. (Electra 62 (1979), pp. 45 - 78) | /11/ | M.R. Marti: Accurate modelling of frequency-dependent transmission lines in electromagnetic transient simulations. (IEEE Trans. PAS 101 (1982), pp. 147 - 157) |
| /5/ | H.W. Dommel, W.S. Meyer: Computation of electromagnetic transients. (Proc. IEE 62 (1974), pp. 983 - 993) | /12/ | W.T. Weeks, L.L. Wu, M.F. McAllister, A. Singh: Resistive and inductive skin effect in rectangular conductors. (IBM Journal of Research and Development, 23 (1979), pp. 652 - 660) |
| /6/ | B. Kulicke: Netomac digital program for simulating electromechanical and electromagnetic transient phenomena in a.c. systems. (Translation from: Elektrizitätswirtschaft 78 (1979), pp. 18 - 23) | /13/ | J.R. Carson: Wave propagation in overhead wires with ground return. (Bell Syst. Tech. Journal, 5 (1926), pp. 539 - 554) |
| /7/ | M. Erche: Network analyzer for studies of electromagnetic transients in high-voltage networks. (Siemens Power Engineering & Automation 7 (1985), pp. 285 - 290) | /14/ | F. Pollaczek: Über das Feld einer unendlich langen wechselstromdurchflossenen Einfachleitung. (Elektrische Nachrichtentechnik, 3 (1926) pp. 339 - 359) |

- and: Über die Induktionswirkungen einer Wechselstrom-einfachleitung.
(Elektrische Nachrichtentechnik, 4 (1927) pp. 18 - 30) /25/ E.J. Tuohy, J. Panek: Chopping of transformer magnetizing currents. Part I: Single phase transformers (IEEE Trans. PAS 97 (1978), pp. 261 - 268)
- /15/ R. Hartenstein, H.J. Koglin and V. Rees: Ersatzschaltbild von HGÜ-Leitungen für symmetrischen und unsymmetrischen Betrieb im Frequenzbereich von 0 bis 100 kHz. (ETZ-A, 93 (1972), pp. 148 - 152) /26/ K.-D. Dettmann: Ausgleichsverfahren zur Bestimmung technisch glatter Magnetisierungskennlinien als Grundlage zur Simulation elektrischer Netzwerke mit nicht-linearen Induktivitäten. (ETZ-Archiv 6 (1984), pp. 115 - 120)
- /16/ C. Gary: Approche complete de la propagation multifilaire en haute frequence par utilisation des matrices complexes. (EdF Bull. de la Direction des Etudes et Recherches, Serie B, (1976) 3/4 pp. 5 - 20) /27/ P. Parrott (CIGRE WG 13.05): A review of transformer TRV conditions. (Electra 102 (1985), pp. 87 - 118)
- /17/ J.R. Marti, H.W. Dommel, L. Marti, V. Brandwajn: Approximate transformation matrices for unbalanced transmission lines. (9th Power Syst. Conf. 1987 Lisbon) /28/ A. Sabot: Transient recovery voltage behind transformer: Calculation and measurement. (IEEE Trans. PAS 104 (1985), pp. 1916 - 1921)
- /18/ CIGRE WG 33/13.09: Very fast transient phenomena associated with gas insulated substations. (CIGRE report 33-13, 1988) /29/ H. Waldmann, M. Weibelzahl, J. Wolf: Ein elektronisches Modell der Synchronmaschine. (Siemens Forsch.- und Entwicklungs-Ber. 1 (1972), pp. 157 - 166)
- /19/ V. Brandwajn, H.W. Dommel, I.I. Dommel: Matrix representation of three-phase n-winding transformers for steady-state and transient studies. (IEEE Trans. PAS 101 (1982), pp. 1369 - 1378) /30/ D. Kind: Die Aufbaufläche bei Stoßspannungsbeanspruchung technischer Elektrodenanordnungen in Luft. (ETZ-A 79 (1958), pp. 65 - 69)
- /20/ E.C. Cherry: The duality between electric and magnetic circuits and the formation of transformer equivalent circuits. (Proc. Phys. Soc. (B) 62 (1949), pp. 101 - 111) /31/ M. Cazzani, M. Lissandrin, S. Manganaro, G. Mazza: Behaviour of EHV and UHV circuit-breakers equipped with resistors during the making operations. (CIGRE Report 13-10, 1978)
- /21/ L. Krähenbühl, B. Kulicke, A. Webs: Simulationsmodell eines Mehrwicklungstransformators zur Untersuchung von Sättigungsvorgängen (Simulation model of a multi-winding transformer for the investigation of saturation phenomena). (Siemens-Forsch.- und Entwicklungs-Ber. 12 (1983), pp. 232 - 235). /32/ B. Kulicke, H.-H. Schramm: Clearance of short-circuits with delayed current zeroes in the Itaipu 550-kV-Substation. (IEEE Trans. PAS 99 (1980), pp. 1406 - 1414)
- /22/ T. Adielson, A. Carlson, H.B. Margolis, J.A. Halladay: Resonant overvoltages in EHV transformers - Modelling and application. (IEEE Trans. PAS 100 (1981), pp. 3563 - 3572) /33/ CIGRE WG 13.01: Practical application of arc physics in circuit breakers. Survey of calculation methods and application guide. (Electra 118 (1988), pp. 65 - 79)
- /23/ R.C. Degeneff: A general method for determining resonances in transformer windings. (IEEE Trans. PAS 96 (1977), pp. 423 - 430) /34/ WG 13.02: Interruption of small inductive currents. Chapter 1 and 2 (Electra 72 (1980), pp. 73 - 103); Chapter 4, Part A (Electra 101 (1985), pp. 13- 39)
- /24/ D. Povh, W. Schultz: Analysis of overvoltages caused by transformer magnetizing inrush currents. (IEEE Trans. PAS 97 (1978), pp. 1355 - 1365) /35/ A. Bargigia, A. Porrino, G. Rizzi, G. Santagostino, B. Mazzoleni: Contribution to the choice of the dielectric withstand levels of SF₆ gas insulated substations. (CIGRE Report 33-13, 1984)
- /36/ K. Alstad, T. Henriksen, J. Huse, A. Schei: Lightning impulse flashover criterion for overhead line insulation. (ISH Milan, 1979, paper 42.19)

- /37/ A. Pigini et al: Performance of large air gaps under lightning overvoltages: Experimental study and analysis of accuracy of predetermination methods. Paper 88 SM 592-8, IEEE PES Summer Meeting 1988
- /38/ M.A. Sargent, M. Darveniza: Tower surge impedance. (IEEE Trans. PAS 88 (1969), pp. 680 - 687)
- /39/ W.A. Chisholm, Y.L. Chow, K.D. Srivastava: Travel time of transmission towers. (IEEE Trans. PAS 104 (1985), pp. 2922 - 2928)
- /40/ A.C. Liew, M. Darveniza: Dynamic model of impulse characteristics of concentrated earths. (Proc. IEE 121 (1974), pp. 123 - 125)
- /41/ A.J. Eriksson: Transient impedance of earthing systems. (Report presented to CIGRE SC 33-Colloquium 1981, Rio de Janeiro. Now included in a report of CIGRE WG 33.01 going to be published in Electra in 1990)
- /42/ A.P. Meliopoulos, M.G. Moharam: Transient analysis of grounding systems. (IEEE Trans. PAS 102 (1983), pp. 389 - 399)
- /43/ F.F. Kuo: Network analysis and synthesis (John Wiley and Sons, New York, 1966)
- /44/ A.S. Morched, V. Brandwajn: Transmission network equivalents for electromagnetic transients studies. (IEEE Trans. PAS 102 (1983), pp. 2984 - 2994)
- /45/ WG 36.05: Harmonics, characteristic parameters, methods of study, estimates of existing values in the network. (Electra 77 (1981), pp. 35 - 54)
- /46/ A.S. Morched, P. Kundur: Identification and modelling of load characteristics at high frequencies. (IEEE Trans. PWRD 2 (1987), pp. 153 - 160)
- /47/ H.W. Dommel, A. Yan, Shi Wei: Harmonics from transformer saturation (IEEE Trans. PWRD 1 (1986), pp. 209 - 215)

Appendix 1: Internal impedance of conductors

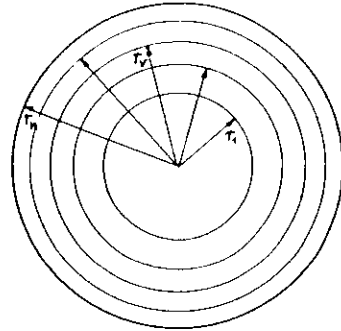

A conductor of circular cross section and length s has an internal inductance and resistance of

$$L_i = \frac{\mu s}{8 \pi r} \quad \text{and} \quad R_i = \frac{\rho \cdot s}{\pi r^2} = \frac{1}{G_i}$$

To represent its frequency dependent impedance it can be subdivided into any number n of (hollow) cylinders with an internal inductance L and conductivity $G_v = 1/R_v$ (Fig. A1). This model can be replicated by an equivalent circuit consisting of a series connection of each (hollow) cylinder.

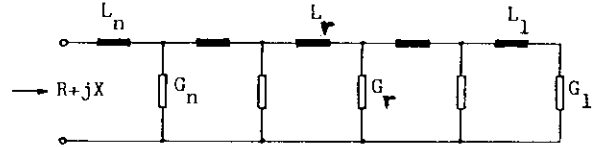

The values L_v and G_v of each (hollow) cylinder can be calculated according to the formulas given in the table of Fig. 1A, depending on the radius r_v . Using for the subdivision of the radius the relation

$$r_v = r_n \cdot \left(\frac{v}{n}\right)^m$$

a good approximation of the real $R(f)$ - and $X(f)$ -curves can be achieved by varying the exponent m . The example with $n = 5$ and $m = 0.15$ shows good agreement of the equivalent circuit with real performance of the conductor up to about 100 kHz.

	r_v optional	$r_v = r_n \left(\frac{v}{n}\right)^m$
L_v	$L_i \cdot \left[1 - \left(\frac{r_{v-1}}{r_v}\right)^4\right]$	$L_i \cdot \left[1 - \left(\frac{v-1}{v}\right)^{4m}\right]$
G_v	$G_i \cdot \left(\frac{r_v^2 - r_{v-1}^2}{r_n^2}\right)$	$G_i \cdot \left[\left(\frac{v}{n}\right)^{2m} - \left(\frac{v-1}{n}\right)^{2m}\right]$

Vice versa a frequency dependent impedance

$$R = R_i, \quad X = 2 \pi f L_i \quad \text{for } f \ll f_x$$

$$R = R_i \sqrt{\frac{f}{f_x}}, \quad X = 2 \pi f L_i \sqrt{\frac{f}{f_x}} \quad \text{for } f \gg f_x$$

can be represented by such an equivalent circuit.

It should be mentioned, however, that there is the correspondence

$$2 \pi f_x = \frac{R_i}{L_i}$$

Therefore, if R_i and f_x are fixed, also L_i is fixed. But in practical cases this does not cause trouble, since the external inductances normally are higher than the internal ones.

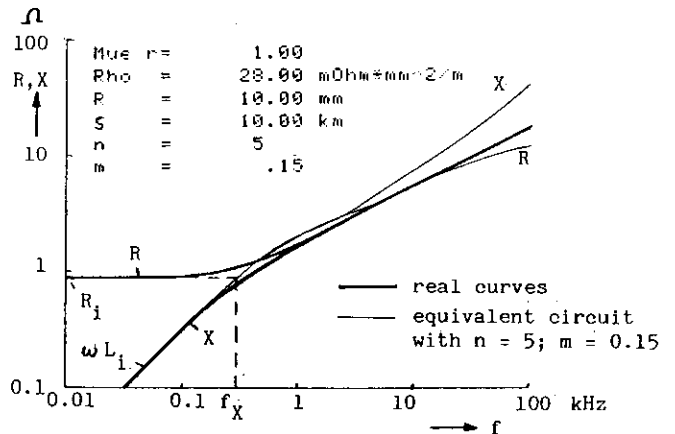

Fig. A1: Equivalent circuit of frequency dependent internal impedance of a conductor

Le CIGRÉ a apporté le plus grand soin à la réalisation de cette brochure thématique numérique afin de vous fournir une information complète et fiable.

Cependant, le CIGRÉ ne pourra en aucun cas être tenu responsable des préjudices ou dommages de quelque nature que ce soit pouvant résulter d'une mauvaise utilisation des informations contenues dans cette brochure.

Publié par le CIGRÉ
21, rue d'Artois
FR-75 008 PARIS
Tél. : +33 1 53 89 12 90
Fax : +33 1 53 89 12 99

Copyright © 2000

Tous droits de diffusion, de traduction et de reproduction réservés pour tous pays.

Toute reproduction, même partielle, par quelque procédé que ce soit, est interdite sans autorisation préalable. Cette interdiction ne peut s'appliquer à l'utilisateur personne physique ayant acheté ce document pour l'impression dudit document à des fins strictement personnelles.

Pour toute utilisation collective, prière de nous contacter à sales-meetings@cigre.org

The greatest care has been taken by CIGRE to produce this digital technical brochure so as to provide you with full and reliable information.

However, CIGRE could in any case be held responsible for any damage resulting from any misuse of the information contained therein.

*Published by CIGRE
21, rue d'Artois
FR-75 008 PARIS
Tel : +33 1 53 89 12 90
Fax : +33 1 53 89 12 99*

Copyright © 2000

All rights of circulation, translation and reproduction reserved for all countries.

No part of this publication may be produced or transmitted, in any form or by any means, without prior permission of the publisher. This measure will not apply in the case of printing off of this document by any individual having purchased it for personal purposes.

For any collective use, please contact us at sales-meetings@cigre.org

Le CIGRÉ a apporté le plus grand soin à la réalisation de cette brochure thématique numérique afin de vous fournir une information complète et fiable.

Cependant, le CIGRÉ ne pourra en aucun cas être tenu responsable des préjudices ou dommages de quelque nature que ce soit pouvant résulter d'une mauvaise utilisation des informations contenues dans cette brochure.

Publié par le CIGRÉ
21, rue d'Artois
FR-75 008 PARIS
Tél. : +33 1 53 89 12 90
Fax : +33 1 53 89 12 99

Copyright © 2000

Tous droits de diffusion, de traduction et de reproduction réservés pour tous pays.

Toute reproduction, même partielle, par quelque procédé que ce soit, est interdite sans autorisation préalable. Cette interdiction ne peut s'appliquer à l'utilisateur personne physique ayant acheté ce document pour l'impression dudit document à des fins strictement personnelles.

Pour toute utilisation collective, prière de nous contacter à sales-meetings@cigre.org

The greatest care has been taken by CIGRE to produce this digital technical brochure so as to provide you with full and reliable information.

However, CIGRE could in any case be held responsible for any damage resulting from any misuse of the information contained therein.

*Published by CIGRE
21, rue d'Artois
FR-75 008 PARIS
Tel : +33 1 53 89 12 90
Fax : +33 1 53 89 12 99*

Copyright © 2000

All rights of circulation, translation and reproduction reserved for all countries.

No part of this publication may be produced or transmitted, in any form or by any means, without prior permission of the publisher. This measure will not apply in the case of printing off of this document by any individual having purchased it for personal purposes.

For any collective use, please contact us at sales-meetings@cigre.org