

237

**STATIC SYNCHRONOUS
COMPENSATOR (STATCOM) FOR
ARC FURNACE AND FLICKER
COMPENSATION**

**Working Group
B4.19**

December 2003



CIGRE

**STATIC SYNCHRONOUS COMPENSATOR (STATCOM)
FOR ARC FURNACE AND FLICKER COMPENSATION**

**Prepared by
Working Group B4.19
CIGRE Study Committee B4**

**Edited by
Dr I Arslan Erinmez**

September 2003

*CIGRE STATCOM FOR ARC FURNACE AND FLICKER COMPENSATION
LIST OF CONTRIBUTING MEMBERS*

CIGRE Study Committee B4

Working Group B4.19

STATIC SYNCHRONOUS COMPENSATOR (STATCOM)
FOR ARC FURNACE AND FLICKER COMPENSATION

List of Contributing Members

Dr I A Erinmez (Chairman), The National Grid Company plc - United Kingdom

Mr Guillaume de Preville, Alstom Transmission and Distribution- France

Prof Ani M Gole, University of Manitoba - Canada

Mr Tomas Gustafsson, ABB Power Systems - Sweden

Dr Laszlo Gyugyi, Independent Consultant, formerly Siemens Power Transmission and Distribution and Westinghouse - USA

Mr Dan Kell, Manitoba HVDC Research - Canada

Mr Matti Lahtinen, Fingrid Oyj - Finland

Mr Claudio Pincella, CESI - Italy

Dr Michael Weinhold, Siemens AG - Germany

Other Contributions received from

Prof Dr Ing Detmar Arlt, Duesseldorf University - Germany

Dr Ing Wolfgang Hoerger, Siemens AG – Germany

Mr Shoichi Irokawa, Toshiba Corporation - Japan

Dr Masuo Goto, Hitachi - Japan

Dr Masatoshi Takeda, Mitsubishi Electric Corporation - Japan

CIGRE

**STATIC SYNCHRONOUS COMPENSATOR (STATCOM)
FOR ARC FURNACE AND FLICKER COMPENSATION**

**Prepared by
Working Group B4.19
CIGRE Study Committee B4**

**Edited by
Dr I A Erinmez**

September 2003

**Report presented at the request of the Chairmen of Study Committee B4
Marcio Szechtman/ Prof Dr Dusan Povh**

FOREWORD

STATIC SYNCHRONOUS COMPENSATOR (STATCOM) FOR ARC FURNACE AND FLICKER COMPENSATION

1. INTRODUCTION

Technological developments over the last three decades made arc furnace based steel making ever more popular both in well-developed and developing countries. In addition, use of technologies utilising large pulsed type load characteristics such as resistance and/or welding equipment, rolling mills, wood chip mills, rock crushing equipment have become widespread. The increasing number and size of new arc furnaces and fluctuating loads being installed caused power quality problems such as flicker, harmonics, and unbalance in the majority of cases. For example, typical arc furnaces in 1980's were rated 30-40MVA with 40-50 tons of scrap metal processing capacity. Currently typical arc furnaces are rated at 160-200MW and have a scrap metal processing capacity of 150-200 tons. In a minority of cases, torsional oscillations in generator shaft systems were also experienced due to sub-synchronous resonance induced by the real power fluctuations of such loads. These power quality problems have become a great concern to electric utilities all over the world. In absence of other technologies offering better solutions Static Var Compensators (SVCs) have been widely utilised to reduce flicker. In fact of some 900 SVC applications around the world to date some 600 or so have been utilised in remedying power quality problems the majority of which were flicker reduction applications.

Over the last three decades increased use of high technology equipment caused an appreciable increase of power supply quality problems. This was partially due to the higher sensitivity of such equipment to reductions in supply quality combined by increased consumer awareness of widespread consequences of such problems. In addition the lack of sufficiently low system impedance (transmission system strength) for connecting such loads and the performance limits of the SVC created an urgent need for a new technological solution.

SVCs have been used for arc furnace and flicker compensation for over three decades. The technology, based on thyristor-controlled reactor, is mature and its limits for flicker reduction are well understood. These limits are related to the inherent time delay of the thyristor controlled reactor (TCR), the dynamic interactions between the highly resonant LC filter network of the SVC, the arc furnace and the TCR, and the SVCs inherent inability to compensate active (real) power fluctuation. Because of these limitations, the SVC is, in general, only able to reduce the flicker by a factor close to two. However, in many applications a flicker reduction factor greater than two is usually required to meet the power quality requirements of the power system to which the arc furnace or fluctuating load is connected. The limitations of the SVCs due their inherent characteristics also meant that no further flicker reduction could be obtained by applying SVCs with increased ratings.

CIGRE STATCOM FOR ARC FURNACE AND FLICKER COMPENSATION
FOREWORD

The STATCOM, based on the operating experience in technology demonstration projects at Sweden, Japan and the USA, demonstrated that a reduction in flicker by a factor of four to six was achievable when compared with an SVC of comparable size and cost. Furthermore, due to the inherent characteristics of STATCOM, application of additional STATCOM units would result in further significant reduction in flicker i.e., unlike in the case of SVC, increasing the STATCOM rating would result in a larger reduction in flicker.

In recognition of the potential benefits of the application of STATCOM and the positive experience from the technology demonstration applications, CIGRE Study Committee 14 (now SC B4) extended the terms of reference of WG 14.19 at its Paris meeting in September 1998. The WG was requested to prepare an additional report on the current status of arc furnace and flicker compensation by STATCOM and provide an application guide following completion of its work on transmission applications of STATCOM [1].

In preparing this additional report the WG was given the objective to:

1. Consider STATCOM compensation approaches (Japan, Sweden, USA) in terms of power circuit approaches, filtering requirements, control approach, flicker reduction and other operating benefits as well as equipment losses;
2. Define arc furnace compensation objectives;
3. Describe power circuit approaches with advantages and disadvantages;
4. Describe basic control approaches;
5. Discuss equipment rating, performance and other application issues;
6. Discuss hybrid flicker compensation (e.g., Filters, SVC and STATCOM) approaches;
7. Prepare application guidance.”

The WG (now designated as WG B4.19) held its first meeting on its additional task on 28/29 February 2000. It was agreed that the report would be especially focused in providing practising electric power utility engineers with the appropriate material which would enable practical application of STATCOM to improving power quality in arc furnace and flicker compensation applications. It was also agreed that the existing accepted practices, standards, definitions and measurement methods for evaluating flicker i.e., the practices developed with other agencies such as UIE (International Union for Electricity Applications) and other international practices would be used throughout the report. The WG B4.19 has completed its report entitled “Static Synchronous Compensator (STATCOM) for Arc Furnace and Flicker Compensation” in September 2003.

2. ARC FURNACE AND FLICKER COMPENSATION OBJECTIVES

Chapter 1 of the report is devoted to the description of the arc furnace and flicker compensation objectives. The acceptable limits of flicker, repetitive voltage fluctuations and the methods of measurement incorporated into existing international standards are briefly reviewed. The types of power system loads requiring compensation and the methods of compensation applied to date are examined. The compensation methods applied over the years that were examined include:

- Increasing the short circuit power infeed to the furnace by transferring its connection to a higher voltage level;
- Increasing the short circuit power infeed by installing synchronous compensators;

- Application of passive a.c. filters for power factor correction;
- Application of stepped series reactors and thyristor controlled series reactors;
- Application of series saturable reactors; and
- Application of Static Var Compensators (SVCs).

SVCs are by far the most common flicker compensation method utilised to date with a typical installation consisting of a thyristor controlled reactor (TCR) and some with a.c. filters for eliminating the harmonics generated by the TCR. The rating of the SVC is approximately of the same order of the arc furnace rating. The maximum achievable flicker improvement ratio (FI), expressed as the ratio between the short term flicker severity (P_{st}) values without and with the compensating device, i.e., $FI = P_{st\text{without}} / P_{st\text{with}}$, is in the order of two with high power arc furnaces connected at higher voltage levels in the power system. The flicker improvement ratio is around 1.6-1.7 for a typical installation. The limitations of SVC in achieving higher values of flicker reduction factor are caused by the inherent time delay of the TCR and by the dynamic interactions between the resonant a.c. filters of the SVC and the network.

The fundamental reasons for utilisation of STATCOM are explored together with the efficiency and economic benefits to the arc furnace/flicker inducing load owner/operator, as well as other customers connected to the power system are explored.

3. STATCOM COMPENSATION APPROACHES

In Chapter 2 of the report the basic approaches used in application of a STATCOM for arc furnace and flicker compensation are described. Basic circuit and general control approaches are examined in relation to the application requirements. The basic compensation requirements of the arc furnace load, for each discrete instant of time, can generally be stated as follows:

- (1) The magnitude of the reactive component of the positive sequence current must be zero or constant.
- (2) The negative sequence current must be zero.

In addition, a voltage sourced converter based static synchronous compensator (STATCOM), functioning as a static generator has the capability of both generating reactive power for and exchanging real power with the a.c. system. It can thus provide both the necessary reactive compensation to eliminate or reduce reactive power demand, balance the load, and minimise the real power fluctuation. Thus, an auxiliary requirement for ideal arc furnace compensation can be formulated as:

- (3) The real power fluctuation over a defined interval of time must be zero, or the real power absorbed over a defined time interval from the a.c. system must be constant.

The various basic circuit and control approaches are then examined in detail, and advantages and disadvantages of each configuration are discussed. The Chapter concludes with brief examples of flicker reduction achieved in technology demonstration and actual commercial installations. For example, the flicker reduction observed in one installation was the 95% probability short term flicker severity $P_{st95\%} = 3.75$ without the STATCOM,

reducing to $P_{st95\%} = 0.76$ with the STATCOM in operation indicating that a flicker improvement ratio (FI) of around five times was achieved by the compensator.

4. STATCOM CONTROL APPROACHES

Chapter 3 of the report deals with the basic control approaches used in application of a STATCOM for arc furnace and flicker compensation. The differences in control approaches from the STATCOM for transmission applications are described. In principle, two basic control approaches for mitigating the voltage fluctuation at the point of common coupling to the power system (PCC) can be identified, namely:

1. To compensate the reactive power of the arc furnace and to smooth the fluctuations in active power consumption. This requires energy storage capability in the compensator. As a consequence of applying this approach in full the arc furnace and the compensator appears as a purely resistive load, which changes only its resistance very slowly. However, in order to achieve this the compensator must be able to instantaneously provide energy when the power consumption of the arc furnace changes.
2. The alternative control approach is to let the compensator inject only reactive power such that the voltage fluctuations at the PCC are eliminated. Also the voltage fluctuation at the PCC resulting from changing active power consumption of the arc furnace is cancelled by reactive current injection of the compensator. The advantage of such a control scheme is that the compensator does not require large energy storage equipment, which may result in smaller overall investment cost.

The Chapter then provides an example of a basic practical control implementation in relation to detailed control implementation variations detailed in Appendix B.

5. STATCOM RATING AND PERFORMANCE CONSIDERATIONS

Chapter 4 of the report is devoted to the consideration of defining the relationship between the flicker compensation performance objectives and the STATCOM rating. The factors playing a major role in defining this relationship such as the arc furnace rating and operational parameters are examined with a view to identify their relative impact on STATCOM rating in achieving the compensation objectives under all possible operational conditions. Approximate formulae for estimating the flicker levels of a new furnace installation derived from surveys are compared with actual performance with compensation. The behaviour of an uncompensated arc furnace is analysed based upon measurements taken at an actual arc furnace installation. The flicker reduction performance is then calculated on an EMTDC software model with the existing SVC compensator at the installation to verify the measured flicker performance.

Once the Flicker Reduction Factor ($FR = P_{st \text{ with}} / P_{st \text{ without}} = 1/FI$), obtainable from measured quantities is verified, then the performance that can be expected from an existing or new arc furnace installation compensated with an SVC or STATCOM of a specific rating can be calculated.

The Chapter also makes recommendations on STATCOM type compensation rating and compares it with the rating of SVC type compensation.

6. APPLICATION OF STATCOM FOR ARC FURNACE COMPENSATION

The considerations of STATCOM applications for arc furnace compensation over the traditional compensation methods as well as the application of hybrid compensation methods are examined in Chapter 5 of the report. This Chapter also provides guidance on the functional specification of STATCOM for arc furnace flicker compensation, covering the information requirements of the utility, arc furnace plant owner/operator as well as the reactive compensation manufacturer in:

1. General Requirements
2. Power System Characteristics
3. Steady-state Performance
4. Dynamic Performance, Control and Monitoring Facilities
5. Performance Tests
6. Site and Environmental
7. Other Considerations

The Chapter concludes with the listing of equipment design standards relevant to the components forming the STATCOM.

7. EXAMPLES OF STATCOM APPLICATIONS FOR ARC FURNACE AND FLICKER CONTROL

Finally, Chapter 6 of the report provides a detailed description of existing and proposed installations. The rating and basic parameters of each installation are presented in tabular format and detailed description of each application is also provided as follows.

- Seguin, Texas, USA
- Hagfors, Sweden
- Trier, Germany
- Tornio, Finland
- The 12 STATCOM Compensator Installations for Arc Furnace Flicker Compensation in Japan at the arc furnace installations at various steel companies.

8. CONCLUDING REMARKS

The WG B4.19 members hope that this report has demonstrated the value of STATCOM as an established technology for arc furnace and flicker compensation. The WG are also confident that the report will be of practical value to all practising engineers who are interested in the practical application of this new technology to satisfactorily address the power quality problem posed by arc furnaces and other flicker generating power system loads.

Dr I A Erinmez, Chairman WG B4.19
September 2003

REFERENCES

- [1] Erinmez, I.A. and Foss, A.M. "Static Synchronous Compensator (STATCOM)" Report prepared by CIGRE Working Group 14.19, published by CIGRE as "Technical Brochure No 144" in August 1999

CONTENTS

Chapter 1. ARC FURNACE AND FLICKER COMPENSATION OBJECTIVES *Prepared by Claudio Pincella*

1.1	INTRODUCTION	1-1
1.2	THE NEED TO COMPENSATE FLICKER	1-1
1.3	LIMITS OF ACCEPTABLE FLICKER AND REPETITIVE VOLTAGE FLUCTUATIONS IN POWER SYSTEMS	1-2
	<i>1.3.1 Introduction</i>	<i>1-2</i>
	<i>1.3.2 Prediction of Flicker Level at Planning Stage</i>	<i>1-3</i>
	<i>1.3.3 IEC Standards and Recommendations</i>	<i>1-3</i>
	<i>1.3.4 CENELEC EN 50160 Standard</i>	<i>1-9</i>
	<i>1.3.5 IEEE Standards</i>	<i>1-10</i>
	<i>1.3.6 Standards utilised in Japan and Far Eastern countries</i>	<i>1-10</i>
1.4	BASIC DESCRIPTION OF THE OPERATION OF ELECTRIC ARC FURNACES	1-12
	<i>1.4.1 The a.c. Arc Furnaces</i>	<i>1-12</i>
	<i>1.4.2 The d.c. Arc Furnaces</i>	<i>1-14</i>
1.5	EFFICIENCY AND ECONOMIC BENEFITS OF COMPENSATION	1-17
	<i>1.5.1 Increased Production</i>	<i>1-17</i>
	<i>1.5.2 Advantages of Higher Active Power Availability</i>	<i>1-19</i>
	<i>1.5.3 Energy Savings</i>	<i>1-20</i>
	<i>1.5.4 Electrode Savings</i>	<i>1-21</i>
1.6	METHODS OF COMPENSATION	1-21
	<i>1.6.1 Reactive Compensation Approaches</i>	<i>1-21</i>
	<i>1.6.2 Reasons for Utilising STATCOM for Arc Furnace Compensation</i>	<i>1-23</i>
1.7	REFERENCES	1-24

Chapter 2. STATCOM COMPENSATION APPROACHES *Prepared by Laszlo Gyugyi*

2.1	ELECTRICAL CHARACTERISTICS OF THE ARC FURNACE LOAD	2-1
2.2	COMPENSATION REQUIREMENTS	2-3
2.3	VECTOR REPRESENTATION OF ELECTRICAL VARIABLES	2-10
2.4	COMPENSATION BY STATCOM	2-13
2.5	BASIC STATCOM POWER CIRCUIT APPROACHES	2-19
2.6	FLICKER REDUCTION ACHIEVED BY STATCOM IN ACTUAL INSTALLATIONS	2-28
2.7	ACKNOWLEDGEMENTS	2-33
2.8	REFERENCES	2-34

CIGRE STATCOM FOR ARC FURNACE AND FLICKER COMPENSATION
CONTENTS

Chapter 3. STATCOM CONTROL APPROACHES

Prepared by Guillaume de Preville, Michael Weinhold, Ani Gole and Dan Kell

3.1 INTRODUCTION	3-1
3.2 REQUIREMENTS FOR ARC FURNACE FLICKER MITIGATION	3-1
3.3 DIFFERENCES FROM TRANSMISSION STATCOM CONTROL	3-3
3.4 BASIC TOPOLOGY AND OPERATING PRINCIPLE OF STATCOM	3-4
3.5 EXAMPLE OF A STATCOM CONTROL IMPLEMENTATION FOR FLICKER MITIGATION	3-6
3.6 OTHER METHODS OF STATCOM CONTROL IMPLEMENTATION FOR FLICKER MITIGATION	3-12
3.7 REFERENCES	3-13

Chapter 4. STATCOM RATING AND PERFORMANCE CONSIDERATIONS

Prepared by Matti Lahtinen and Dan Kell

4.1 INTRODUCTION	4-1
4.2 FLICKER ESTIMATION FOR A NEW ARC FURNACE	4-1
4.3 ANALYSIS OF UNCOMPENSATED ARC FURNACE	4-2
4.4 FLICKER REDUCTION FACTOR CALCULATIONS FOR EXISTING SYSTEM	4-8
4.5 FLICKER REDUCTION FACTOR CALCULATIONS FOR COMPENSATOR WITH LIMITED CAPACITY	4-10
4.6 CONTROL PERFORMANCE CONSIDERATIONS	4-14
4.7 RECOMMENDATIONS FOR COMPENSATOR RATING	4-17
4.8 COMPARISON OF SVC AND STATCOM RATING	4-18
4.9 REFERENCES	4-19

Chapter 5. APPLICATION OF STATCOM FOR ARC FURNACE COMPENSATION

Prepared by Arslan Erinmez

5.1 INTRODUCTION	5-1
5.2 CONSIDERATIONS IN APPLICATION OF STATCOM FOR ARC FURNACE COMPENSATION	5-1
5.3 FUNCTIONAL SPECIFICATION OF STATCOM FOR ARC FURNACE AND DISTURBING LOAD COMPENSATION APPLICATIONS	5-5
5.4 UTILITY, PLANT OWNER AND COMPENSATOR MANUFACTURER INFORMATION REQUIREMENTS	5-6
5.4.1 <i>General Requirements</i>	5-6
5.4.2 <i>Power System Characteristics</i>	5-7
5.4.3 <i>Steady-state Performance</i>	5-7
5.4.4 <i>Dynamic Performance, Control and Monitoring Facilities</i>	5-8
5.4.5 <i>Performance Tests</i>	5-9
5.4.6 <i>Site and Environmental</i>	5-9
5.4.7 <i>Other Considerations</i>	5-10
5.5 EQUIPMENT DESIGN STANDARDS	5-10
5.6 REFERENCES	5-11

**Chapter 6. EXAMPLES OF STATCOM APPLICATIONS FOR ARC
FURNACE AND FLICKER CONTROL**
*Prepared by Laszlo Gyugyi, Tomas Gustafsson, Shoichi Irokawa and
Arslan Erinmez*

6.1 INTRODUCTION	6-1
6.2 SEGUIN, TEXAS, USA	6-1
6.3 HAGFORS, SWEDEN	6-4
6.4 TRIER, GERMANY	6-7
6.5 TORNIO, FINLAND	6-10
6.6 THE STATCOM COMPENSATOR INSTALLATIONS FOR ARC FURNACE FLICKER COMPENSATION IN JAPAN	6-10
6.7 ACKNOWLEDGEMENTS	6-10
6.8 REFERENCES	6-10
TABLE 6.1 EXISTING AND PROPOSED INSTALLATIONS	6-11

APPENDICES

APPENDIX A STATES OF THE ARC FURNACE A-1
Prepared by Guillaume de Preville

APPENDIX B COMPENDIUM OF STATCOM CONTROL METHODS
Prepared by Guillaume de Preville

B.1 I_D, I_Q COMPENSATION THEORY	B-1
B.2 CONTROL SCHEMES FOR STATCOM	B-7
B.2.1 <i>STATCOM Control Principles</i>	B-7
B.2.2 <i>Vector Control</i>	B-10
B.2.3 <i>Active Filtering Control</i>	B-14
B.2.4 <i>Control Approach for Flicker Mitigation</i>	B-17
B.2.5 <i>Alternative Flicker Control Approach</i>	B-20
B.3 REFERENCES	B-27

**APPENDIX C BRIEF DESCRIPTION OF THE SCHWABE FLICKER METER
EXTENSIVELY USED IN THE USA**

APPENDIX D NOMENCLATURE, ABBREVIATIONS AND GLOSSARY
Prepared by Arslan Erinmez

D.1 NOMENCLATURE	D-1
D.2 ABBREVIATIONS	D-4
D.3 GLOSSARY	D-6

Chapter 1 ARC FURNACE AND FLICKER COMPENSATION OBJECTIVES

Prepared by Claudio Pincella

1.1 INTRODUCTION

Many loads connected to electric power systems can cause power quality problems at all voltage levels and for very different power ratings due to their unbalanced and non-linear behaviour characteristics. However, the main sources of power quality problems affecting large numbers of customers are the high power industrial loads. The rapid large swings in real and reactive power required by such loads causes rapid repetitive voltage variations with appreciable voltage distortion caused by harmonics and unbalance. The residential and other commercial customers who are supplied by the same a.c. network are then subjected to the impact of these rapid variations in disturbances to their equipment and flicker in the light output of their electric lamps.

The main industrial loads likely to cause disturbance to other consumers are:

- resistance welding machines;
- rolling mills;
- mine winders;
- large motors with varying loads;
- large variable speed drives;
- arc furnaces;
- rock/mineral crushing equipment;
- wood chipping mills;
- arc welding plant; and
- power factor correction capacitor switching.

In this Chapter, the main emphasis will be on relatively large arc furnaces loads, whose impact on the electric power system includes flicker (the main concern), harmonics (the overall spectrum that can be generated by an arc furnace), voltage unbalance (created by the operation of the arc furnace) and, in specific cases, the risk of subsynchronous resonance (SSR) and harmonic resonance with nearby generators.

Some form of reactive compensation is usually required to limit the disturbances injected by arc furnaces into the electric power system, in particular the flicker. This is usually achieved by connecting the compensator to the busbar to which the disturbing load e.g., the arc furnace is connected. This document will mainly concentrate on the utilisation of static synchronous compensators (STATCOM) devices to achieve the required level of arc furnace disturbance limitation.

1.2 THE NEED TO COMPENSATE FLICKER

Repetitive voltage fluctuations in power systems need to be controlled to reasonable low levels to reduce their impact on domestic and commercial customers to an acceptable level. The main parameters in this respect are the level of voltage variations caused by the arc furnace operation and the frequency of occurrence of such variations i.e., their repetition rate. The main reason for such control action is the effect of arc furnace operation on the light output of incandescent electric lighting i.e., flicker, that can cause uneasiness and irritation for the eye and therefore to the human being. Flicker can also cause headaches, migraine and increase of epileptic seizures for people affected by that disease.

Usually, in the most sensitive frequency range of the human eye, repetitive voltage variations of a few percent are sufficient to produce uneasiness. On the other hand, such variations that are very low level compared to other disturbances like voltage dips, do not usually cause any impact on the operation of domestic electric equipment.

The most effective way to control voltage fluctuations and therefore to limit flicker, is to compensate the reactive power variations of the fluctuating loads, at least at the medium/high voltage levels. Improved damping performance can also be obtained by compensating the negative sequence component of active power and harmonics.

It should also be stressed that the voltage stabilisation provided by compensation means can improve the productivity of the arc furnaces.

1.3 LIMITS OF ACCEPTABLE FLICKER AND REPETITIVE VOLTAGE FLUCTUATIONS IN POWER SYSTEMS

1.3.1 Introduction

In this section the acceptable limits and relevant measurement methods for flicker and repetitive voltage variations will be summarised mainly by reference to existing national/international standards and/or recommendations.

First of all it should be stressed that the methods of flicker measurement included in IEC standards are mainly based on International Union for Electricity Applications (UIE) work [1-1]. These standards provide two indicators for flicker assessment, i.e., P_{st} (“short term flicker severity”, evaluated by an average over a ten minute observation period) and P_{lt} (“long term flicker severity”, evaluated over an observation period of two hours from twelve P_{st} values). These indicators have been derived on the basis of study results for 230V, 50 Hz incandescent lamps and in particular those rated at 60W, therefore mainly apply to European countries where such lamps are in use.

P_{lt} is evaluated by means of the following formula:

$$P_{lt} = \sqrt[3]{\sum_{i=1}^{12} \frac{P_{st}^3}{12}}$$

Two basic flicker indicators are normally used with a probabilistic approach, by means of the so-called Cumulative Probability Function (CPF), over the total observation period (e.g. a measurement period of one week in accordance with to EN50160 and IEC 61000-3-7. For example, $P_{st99\%}$ means the value of the P_{st} with a 99% probability not to be exceeded over the total measurement period.

Countries outside Europe adopt different types of lamps, e.g. 120V lamps in North America and 100V lamps in Eastern Asia, having different light output response to voltage variations. In particular these lamps are less prone to cause flicker due to their thicker filament construction resulting in higher thermal inertia. Recently an international effort among

Europe, United States of America and Canada [1-2] has provided the technical basis for the inclusion of the 120V, 60W lamp in the UIE/IEC standards.

1.3.2 Prediction of Flicker Level at Planning Stage

On the basis of the results of a large number of measurements taken in arc furnace installations and subsequent studies, a simple empirical prediction formula to estimate flicker level at point of common coupling have been recommended for a.c. arc furnaces [1-1, 1-3], referring in particular $P_{st99\%}$ (short term flicker severity with a 99% probability of not being exceeded over the measurement period):

$$P_{st99\%} = K_{st} \cdot (S_{scf}/S_{sc})$$

where

S_{scf} = the short circuit power of the arc furnace at PCC

S_{sc} = short circuit capacity of the network at PCC

K_{st} = a flicker emission coefficient in the range from 40 to 80, to be applied without any reactive compensation device.

Reference [1-3] suggests that a value of $K_{st} = 75$, should be considered realistic for modern a.c. arc furnaces with long arcs. The short circuit power of the arc furnace is evaluated on the basis of the total impedance between the PCC and the short-circuited furnace electrodes.

1.3.3 IEC Standards and Recommendations

1.3.3.1 Electromagnetic Environment and Compatibility Levels

It is the responsibility of utilities and/or power system operators to ensure the electromagnetic compatibility (EMC) of the whole system and the equipment connected to it. In this respect the compatibility levels have to be considered as reference values for the co-ordination of emission and immunity of equipment connected to the power network. The compatibility levels have to be considered on a statistical basis, generally adopting the principle that the chosen levels will not be exceeded both in time and space with a 95% probability. This approach takes account of the fact that a utility and/or system operator cannot absolutely control all points of a power system at all times. Therefore, evaluation with respect to compatibility levels needs to be made on an overall system basis.

IEC Standards 61000-2-1 [1-4] and 61000-2-2 [1-5] are the general standards which respectively define the different types of disturbances appearing on power systems and the relevant compatibility levels for low voltage (LV) public networks. However, the existing IEC 61000-2-2 does not give any indication for flicker, but only deals with voltage fluctuations in terms of maximum acceptable rectangular (square wave) voltage changes at different repetition rates.

The flicker compatibility levels for LV public networks, in terms of P_{st} and P_{lt} , are given in the Second Edition of the IEC Standard IEC 61000-2-2 [1-6] which is currently in preparation. The proposed values included in this standard are:

Compatibility levels for LV public networks

P_{st}	1.0
P_{lt}	0.8

General compatibility levels for medium voltage (MV) public networks are given in the IEC Standard IEC 61000-2-12 [1-7] which is also currently in preparation. As far as flicker levels are concerned, specific values are not provided but reference is made to the LV compatibility levels where the lighting equipment is actually connected.

1.3.3.2 Flicker Measurements

IEC Standard IEC 61000-4-15 [1-8] is concerned with the functional and design specifications for the UIE/IEC flickermeter, providing the basic information for the design and the instrumentation of an analogue or digital flickermeter. It does not provide information on flicker severity limits. It is based on UIE Guide “Flicker measurement and Evaluation” [1-9] and its output are the two basic parameters to characterise flicker severity, i.e. P_{st} and P_{1t} . As mentioned earlier, this standard actually applies to 230V, 50Hz low voltage networks e.g. in Europe, on the basis earlier referred to the 230V, 60W incandescent lamp. Other flickermeters in common use include the Schwabe flickermeter in USA described in Appendix C and ΔV_{10} meter in Japan described in Section 1.3.6.

The resulting basic curve in Figure 1.1 from the IEC Standard IEC 61000-4-15, plots the maximum tolerable voltage variations as a function of number of rectangular voltage variations, at constant $P_{st} = 1$, that is considered to be the threshold of human sensitivity. This curve has been derived from experiments on human beings confirming the sensitivity thresholds. A qualitative example of the “rectangular voltage variations” used in obtaining this curve is provided in Figure 1.2.

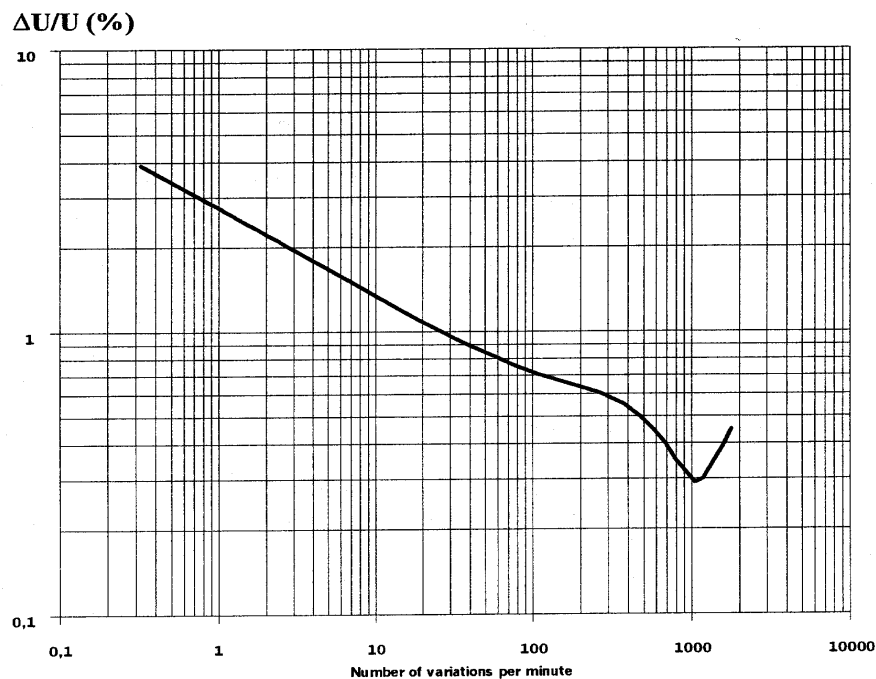

Figure 1.1: Maximum amplitude of the tolerable rectangular voltage variations by human beings as a function of the number of variations, the so called “ $P_{st} = 1$ curve” for 230V, 50Hz power systems.

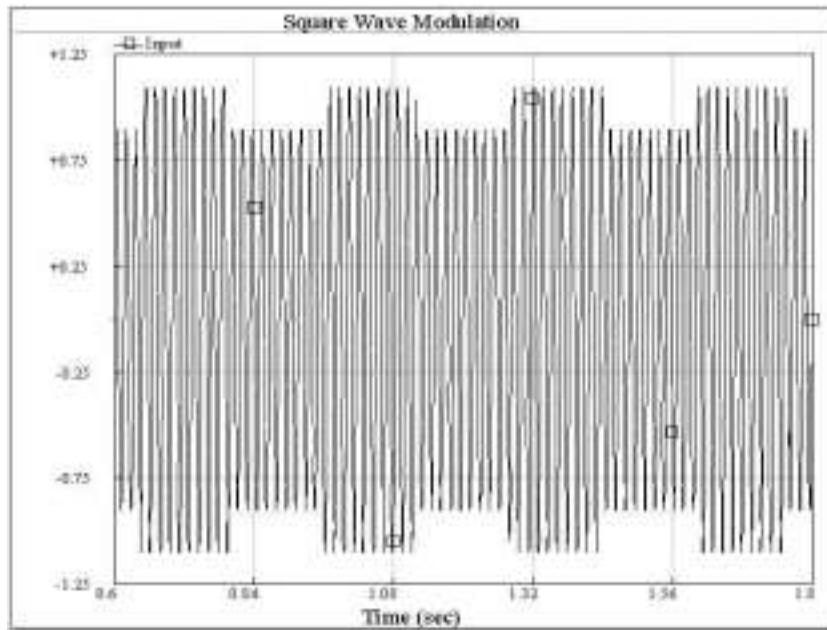

Figure 1.2: Qualitative example of rectangular voltage variations.

This IEC Standard IEC 61000-4-15 [1-10] is currently under revision to include the 120V, 60W lamp characteristic. Figure 1.3 shows, the already implemented 230V, 60W and the currently proposed 120V, 60W lamp characteristics i.e., the “ $P_{st} = 1$ curves” for these lamps.

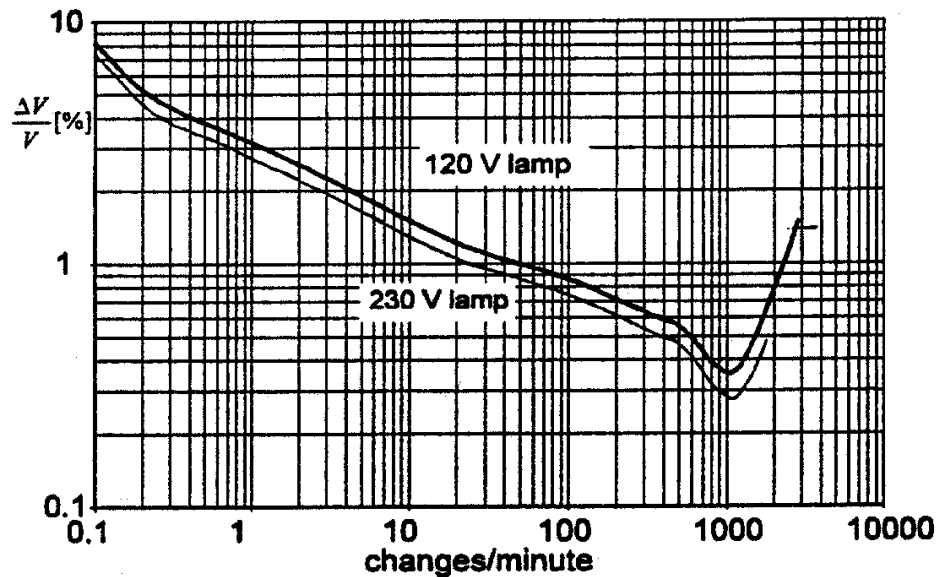

Figure 1.3: UIE implemented “ $P_{st} = 1$ curves” for 230V 60W and proposed 120V 60W lamps for rectangular voltage fluctuations.

A fact that could facilitate the widespread use of the IEC flickermeter in North America and Eastern Asia, in the near future, is its easier adaptability to different types of lamp technology and its ability to separate the voltage measurement process from the process of determining the lamp response. A protocol ensuring correct testing and calibration of flickermeters is currently in preparation by the CIGRE/CIREN Working Group CC02 [1-24].

1.3.3.3 Emission Limits

The emission limit is the admitted disturbance level caused by a particular customer alone, i.e., in this particular case the flicker level for an arc furnace plant.

Low Voltage Systems

IEC Standards 61000-3-3 [1-11] and 61000-3-11 [1-12] cover respectively the acceptable emission limits for appliances having a phase current less than 16A and less than 75A, in the latter case subject to conditional connection.

The limits specified by IEC 61000-3-3 for flicker severity are $P_{st} < 1$ and $P_{lt} < 0.65$. The appliances must comply with these limits, as evaluated by a standardised IEC flickermeter, against a reference low voltage impedance (for single-phase $0.4 + j0.25 \Omega$, for three phase $0.24 + j0.15 \Omega$ for the phase conductor and $0.16 + j0.10 \Omega$ for the neutral).

IEC Standard 61000-3-11 fixes the same P_{st} and P_{lt} limits as IEC 61000-3-3, but does not indicate a reference impedance. The equipment manufacturer must indicate the impedance for which those limits are complied with, with the connection of the appliance being subject to verification of the impedance at the point of common coupling by the electric power utility.

Medium/High Voltage Systems

Although, like all other IEC standards, not mandatory, IEC 61000-3-7 [1-13] provides the appropriate guidelines and recommendations for connection of disturbing loads to electric power systems.

In this document the concept of “planning levels” is introduced, for consideration by the electric power utilities/system operators as part of their internal quality objectives, being equal to or lower than the recommended compatibility levels, in order to assess the impact on the supply system of all consumer loads. Indicative planning levels proposed in this document are as follows although the finally adopted values may vary from case to case dependent upon the assessment carried out by the utility.

Indicative values of planning levels from IEC 61000-3-7

	MV	HV-EHV
P_{st}	0.9	0.8
P_{lt}	0.7	0.6

The above values were proposed with the assumption that the transfer coefficient from HV to LV systems is unity. Taking account that the actual transfer coefficients are often lower, the planning levels could be set higher dependent upon the utility assessment and experience.

IEC 61000-3-7 states that, the measurements on the power system enabling flicker assessments to be made, should be carried out with a minimum duration of one week, comparing the obtained results, in terms of percentiles $P_{st99\%}$ and $P_{1t99\%}$, with the planning levels.

The proposed procedure to evaluate the acceptability of fluctuating loads for connection to MV/HV networks is based on the following three stages of assessment:

Stage 1: Simplified Acceptance

In cases where the power variation ΔS (MVA) of the consumer's fluctuating loads is low compared to short circuit power infeed from the power system S_{sc} (MVA) at the point of common coupling (PCC), automatic acceptance should be considered, without the need for more detailed analysis. The values for MV networks, taking into account the rate of change of the power variations, are the following:

Number of voltage changes per minute $r(\text{min}^{-1})$	$(\Delta S / S_{sc})_{\text{max}}$ (%)
$r > 200$	0.1
$10 \leq r \leq 200$	0.2
$r \leq 10$	0.4

For connection to HV/EHV networks reference is made to the maximum apparent power demand (S_{max}) of the fluctuating loads with respect to S_{sc} at the PCC. In this case the proposed Stage 1 limit is:

$$S_{\text{max}}/S_{sc} \leq 0.1 \%$$

Stage 2: Emission Limits Proportional to the Agreed Power of the Consumer

If the consumer load to be connected does not comply with Stage 1, the specific characteristics of the flicker generating equipment should be evaluated along with the flicker absorption capacity of the system. The flicker absorption capacity of the system is defined on the basis of the planning level and shared among the customers in proportion to their agreed installed power. The sharing takes account of disturbance composition laws among several fluctuating loads and of transfer coefficients among different voltage levels. The main assumption in this instance is that if all users utilise their allowed share of disturbance the planning level of the network should be adhered to and respected by all connectees.

The proposed evaluation procedure is described in detail in the IEC 61000-3-7 document.

Stage 3: Acceptance of Higher Emission Levels on an Exceptional and Precarious Basis

If the installation can not be accepted under Stage 2 evaluation, the consumer and the distribution utility, may bilaterally agree on the connection on an exceptional and precarious basis. In this case a careful study should be performed on the actual and future condition of the system in order to determine the special technical and operational conditions that may be placed on the connections by the electric power utility.

Considering the type and size of the fluctuating loads mainly considered in this document i.e., arc furnaces Stage 2 or Stage 3 procedures usually have to be considered.

Further work is currently in progress in CIGRE WG CC02 to provide guidance and more clearly define compatibility levels for connection of fluctuating loads to higher voltage level networks.

The emission level from a fluctuating load is the flicker, which would be produced in the power system in the absence of any other fluctuating load. For assessment purposes, the minimum period of observation should be one week, and the $P_{st99\%}$ and $P_{lt99\%}$ values resulting from the measurements should be compared with the allowed relevant 99% emission limits. Concerning the 95% values instead of 99%, reference [1-14] suggests, on the basis of the results of several measurement periods, the following relationship:

$$P_{st99\%} = 1.25 P_{st95\%}$$

$$P_{lt95\%} = 0.8 P_{st95\%}$$

In practice, the problem generally encountered is the separation of the background disturbance from the one caused by the specific fluctuating load. The IEC document proposes a procedure for achieving this when the background noise is low ($P_{st} \leq 0.5$), subtracting the measurement results without the specific fluctuating load (including any compensating equipment) to the ones obtained with the specific fluctuating load connected. A cubic summation law is proposed. In case of higher background levels more refined approach needs to be utilised. However, it should be stressed that achieving this can be a hard task and work on this topic is in progress within CIGRE/CIRED WG CC02 [1-15].

1.3.3.4 Immunity

Unfortunately, no standards are currently available on immunity of equipment to flicker, which is caused by voltage fluctuations of relatively low amplitude.

1.3.3.5 Summary on IEC Standards and Recommendations

COMPATIBILITY LIMITS (1)			PLANNING LIMITS (2)			EMISSION LIMITS (3)	
	P_{st}	P_{lt}		P_{st}	P_{lt}	P_{st}	P_{lt}
LV/MV	1.0	0.8	MV	0.9	0.7	Stage 3 procedure	
			HV/EHV	0.7	0.6		

- (1) Values proposed in under way IEC Standards 61000-2 Edition 2 for LV connections and 61000-2-12 for MV connections. The decision on the acceptable Compatibility Limits is the responsibility of utility/system operators.
- (2) These values are mentioned in the IEC 61000-3-7 document and have to be considered in line with the power quality objectives of or targets set for utility/system

operators. They have been estimated assuming a transfer flicker coefficient from HV to LV as being unity. The utility/system operator, through a case-by-case assessment approach, in relation to the actual network characteristics could adopt higher or lower values. The indicated values referred to have a 99% probability of not being exceeded. The 95% probability values could be 1.25 times lower than the 99% values as indicated in reference [1-14].

- (3) The emission limits could be set following the recommendations/guidelines provided by the IEC 61000-3-7 document. The customer is responsible for adhering to the emission limits.

In the previous sections of this chapter the applicable IEC Standards and guidance were summarised. However, it should be borne in mind that the compatibility between the power systems and the disturbing loads, in this case arc furnaces, should be based on an overall system approach. In fact, within the context of recent liberalisation/restructuring of electric power utilities and increased competition, different approaches can be adopted to compensate flicker. The responsibility for the ownership and operation of compensation devices to be installed and the responsibility for compliance with the set flicker levels can be addressed in different ways, depending on the specific situation, e.g., on the degree of liberalisation/restructuring and on the parties involved in the particular electricity market, and could become a matter of competition.

Moreover, there are many Technical Reports which do not bear “Standards” status are available on the procedure to define emission limits for large disturbing loads like arc furnaces at MV/HV voltage levels, and each country has its own practices and legislative constraints. This means that all parties involved i.e., the utility owning the network, the utility operating the network, the arc furnace owner, the arc furnace manufacturer and the compensation equipment manufacturer need to arrive at a specific solution for their particular case.

Another point to be stressed is the fact that the concept of “agreed power” in IEC 61000-3-7 document, as described in stage 2 procedure above, may not always be adopted as a basis to share the total allowed disturbance among the customers.

1.3.4 CENELEC EN 50160 Standard [1-16]

This is a European Standard that specifies the main characteristics of the voltage at the customer’s supply terminals in public low and medium voltage electricity distribution systems under normal operating conditions. The Standard may be superseded in total or in part by the terms of a contract between the individual customers and the electricity supplier. Moreover, the voltage characteristics given in the Standard are not intended to be used as electromagnetic compatibility levels or user emission limits for low frequency conducted disturbances (harmonics, flicker, unbalances, etc.) in public distribution systems.

As far as flicker is concerned only the P_{lt} is taken into account, and in particular “under normal operating conditions, in any period of one week the long term flicker severity caused by voltage fluctuations should be $P_{lt} \leq 1$ for 95% of the time”, but for all locations on the network.

1.3.5 IEEE Standards

Standards commonly utilised in North America are the Institution of Electrical and Electronic Engineers standards namely IEEE 141 [1-17] and IEEE 519 [1-18].

A comparison between the flicker standards from IEEE 141, IEEE 519 and the new proposed by UIE/IEC standard for the 120V lamp, to be included in the revised IEC 61000-4-15 is given in Figure 1.4.

As already mentioned, IEC Standard 61000-4-15 for flickermeter design and specification is currently under revision to include 120V lamp characteristic, to achieve the adoption of a single world standard.

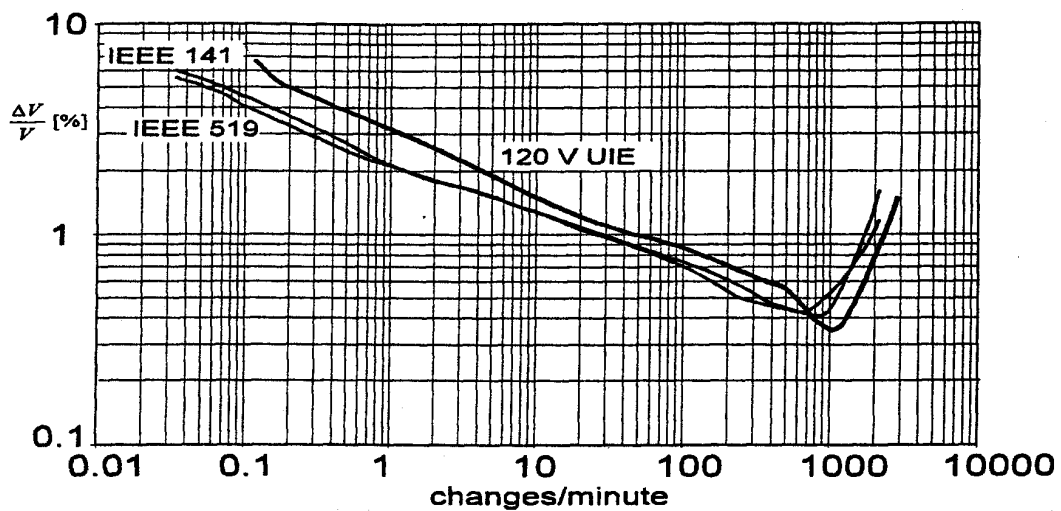

Figure 1.4: Comparison of UIE 120V, $P_{st} = 1$ limit and the IEEE 141 and IEEE 519 limit curves.

1.3.6 Standards Utilised in Japan and Far Eastern Countries

The so called ΔV_{10} method for flicker severity evaluation along with a ΔV_{10} meter have been developed in Japan and are also commonly utilised in the far eastern countries.

The definition of ΔV_{10} [1-19, 1-20] is the average one-minute value of the instantaneous values given by following formula:

$$\Delta V_{10} = \sqrt{\sum_{fn=0.01}^{\infty} (a_{fn} \cdot \Delta V_{fn})^2}$$

where, ΔV_{10} is the indicator for flicker severity.

a_{fn} = Sensitivity coefficients as a function of frequency of sinusoidal fluctuations. These coefficients are derived from the sensitivity curves shown in Figure 1.5 and represent sensitivity of the human eye related to the incandescent lamp characteristics (100 V, 60 W lamp), derived from a lot of experiments performed in Japan.

ΔV_{fn} = Magnitude of sinusoidal voltage component of frequency f_n which is obtained from Fourier Transform of the voltage

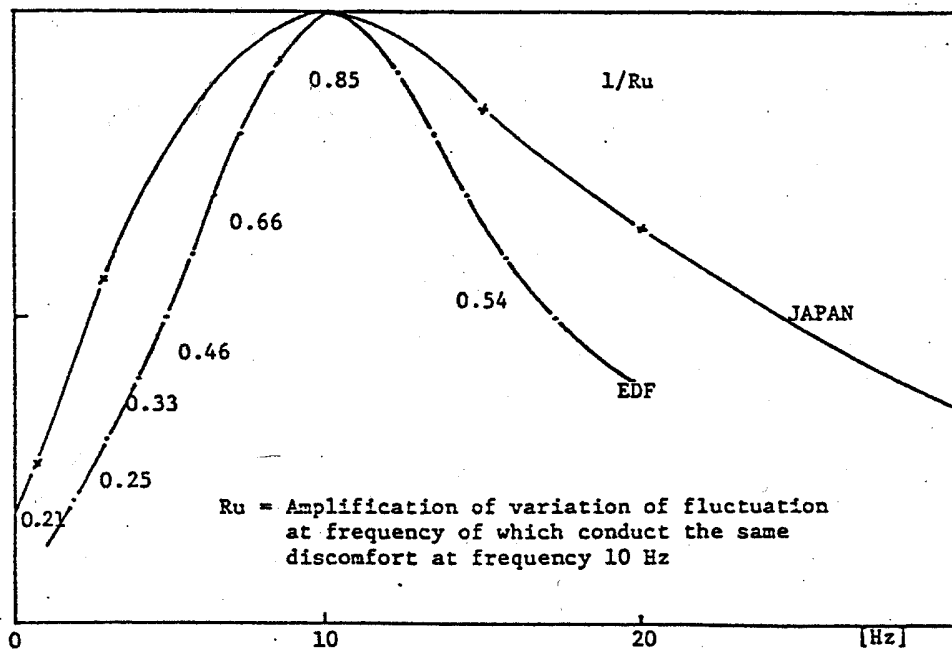

Figure 1.5: Sensitivity characteristic curve used in Japan to define a_{fn} for ΔV_{10} evaluation.

The value to be considered for specification and assessment purposes is the 4th largest one minute ΔV_{10} data out of 60 values in one hour of continuous evaluation. This assumption corresponds to the ΔV_{10} level having a 95% probability not to be exceeded. Figure 1.5 illustrates the sensitivity characteristic curve used in Japan in the application of this method.

As far as the correlation between P_{st} and ΔV_{10} indices is concerned, extensive measurements have been performed in substations of Japanese utilities supplying arc furnace installations [1-21]. A good correlation has been found between the 4th highest value of ΔV_{10} over a period of 1 hour and the highest P_{st} value in the same interval. In particular:

$$\Delta V_{10 \text{ (4th largest)}} / P_{stmax} = 1/3$$

1.4 BASIC DESCRIPTION OF THE OPERATION OF ELECTRIC ARC FURNACES

As previously mentioned the most important disturbing load connected to electric power systems is the arc furnace and in the following section a short description drawing on the distinction between a.c. arc furnaces, which are the most common, and d.c. arc furnaces is given. However, it should be stressed that there is no clear indication whether one technology is predominant. For example, the recently observed trend has been towards increasing use of a.c. arc furnaces, especially for single units of very high power rating.

1.4.1. The a.c. Arc Furnace

There several types of a.c. furnaces, the most common type being illustrated in Figure 1.6, in which the arc is established between the three graphite electrodes and the scrap metal.

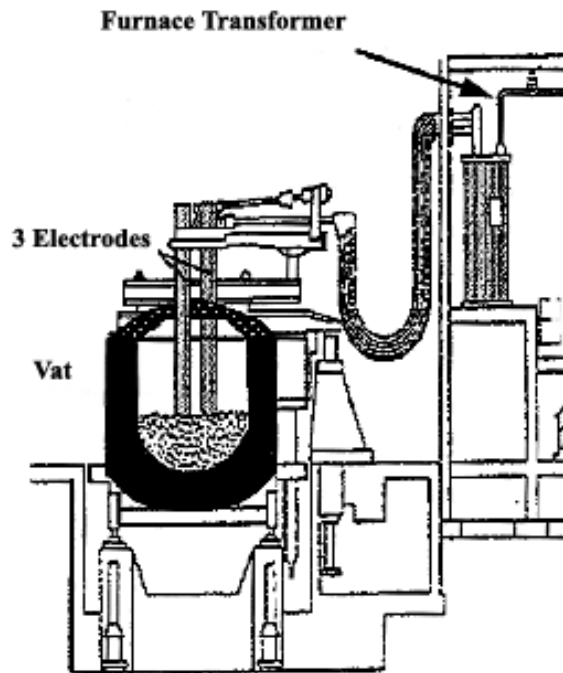

Figure 1.6: Principle layout of an a.c. arc furnace.

There are several phases in the operation of the a.c. arc furnace with each presenting a different impact on the power system in terms of flicker, namely the:

- Boring period
- Melting period
- Refining period.

In terms of the flicker impact on the power system the most critical periods, are the boring and melting periods, which occur every time a new basket with scrap metal is added. These

periods are characterised by strong stochastic variations in the reactive power absorbed by the a.c. arc furnace from the power system. Refining period is less critical in this respect and nowadays this process is often executed in secondary metallurgical equipment and not by the a.c. arc furnace itself.

Prior to 1980, steel-making plants consisted of groups of a.c. arc furnaces of 40 – 50 tons capacity per melting cycle and ratings of 30 – 40 MVA [1-22]. Since 1980 the trend has moved towards a.c. arc furnaces of 120 – 140 tons capacity per melting cycle and ratings of 100 – 120 MVA. At the same time, there was a large increase in the number of daily operating cycles of the furnaces, which increased from 8 – 10 cycles per day to over to 18 – 24 cycles per day. This was mainly due to the practice of carrying out in the refining process in separate ladle-furnaces after the completion of the melting stage. This trend continued in the 1990's with single a.c. arc furnace ratings reaching to 140 – 200 MVA [1-23].

In the meantime, the short circuit power i.e., the short circuit fault level infeed of the power system at points of connection of such arc furnaces, has not increased in the same proportional manner in keeping with the a.c. arc furnace rating, making the flicker disturbances from such arc furnace installations an increasing concern for the electric power utilities.

The power input to the furnace is very sensitive to voltage variations. Thus efficient operation of an electric arc furnace requires a constant and stable voltage supply. The electrical arc furnace does not have any “built-in” compensation mechanism for controlling voltage variations like for instance an electrical motor, which consumes more current when voltage decreases in order to maintain the same torque.

In practice to achieve a stable furnace operation, the power factor for the furnace needs to be maintained between 0.7 to 0.8 pf i.e., the reactive power drawn by the furnace needs to be in the same range as the active power. The reactive power drawn by the furnace will have a major impact on the feeding voltage and will during operation create a voltage drop at the primary side of the furnace transformer. The melting power of the furnace is the product of the arc current and voltage. The voltage drop at the primary side of the furnace transformer will consequently give lower available melting power. Given the continuously changing nature of the arc, dynamically responsive reactive compensation such as SVC and/or STATCOM, able to maintain the power factor reasonably constant and hence stabilise the voltage of the feeding network during the whole scrap metal charge “power-on-time” is therefore absolutely essential. As a consequence of the stabilised voltage, the melting power would be at a high level during the whole melting cycle and the furnace will operate more efficiently.

By definition, losses in the furnace are the difference between the energy supplied from the power system minus the energy utilised in the melt. Some losses, like for instance conductor losses are partly useful. Most of the conductor losses are located in the electrodes, which are mainly situated inside the furnace and contribute therefore to heat the melt. Normally, 2/3 of the losses in the electrodes is considered as useful.

In general, to minimise energy losses, the scrap metal melt process must be completed as fast as possible without any major stoppage. Each time the process stops, like for example when new scrap metal is added i.e., the furnace is charged, heat will be lost from the furnace.

With the stabilised voltage created by the reactive compensation plant i.e., SVC or STATCOM, the power-on-time of the furnace will be reduced. As a consequence energy savings will be achieved. The economic and efficiency benefits obtainable from the addition of reactive compensation in the form of STATCOM or SVC will be discussed in detail in the following sections of this Chapter.

A general diagram illustrating the relationship between the active power (P) and reactive power (Q) drawn by an arc furnace from the power system is provided In Figure 1.7. This is an idealised characteristic which is drawn assuming balanced arc furnace operation and constant feeding voltage i.e., an ideal infinite power system connection for the arc furnace or a voltage maintained ideally constant by adequate reactive compensation means. In Figure 1.7, X_T and R_T represent the total reactances and resistances of the arc furnace and its connections from the constant voltage connection point down to the furnace itself. In practice, the reactances and resistances of the HV transformer, the arc furnace transformer, the LV connections and the resistance of the arc are included in X_T and R_T .

Equations relevant to this circuit are described in [1-1] and the results show that the maximum power available for the furnace, at operating point “O”, is obtained at power factor $\cos\phi = 0.707$ i.e., when the total resistances, including arc resistance are equal to the total reactances. The diagram also illustrates that small variations of active power, cause large variations of reactive power, which of course is the main reason for flicker.

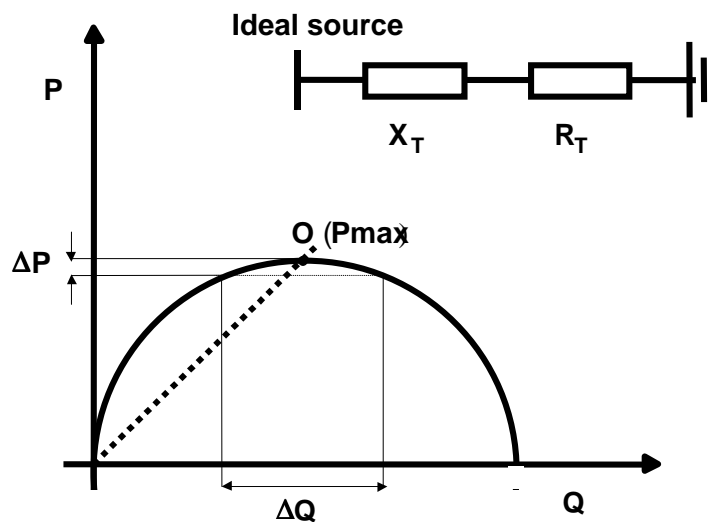

Figure 1.7 Generalised P, Q diagram of an arc furnace.

1.4.2 The d.c. Arc Furnaces

The main difference with respect to the a.c. furnaces is the adoption of power electronics, in particular an a.c./d.c. controlled rectifier for supplying power to the furnace, allowing the

possibility to control the d.c. arc current to fairly constant values, by fast control action on the firing angles of the rectifier.

One of the advantages claimed for this technology is a lower flicker level compared with an a.c. furnace, even if this advantage seem to be less significant with very high power rating [1-14]. This advantage is generally due to the better control possibilities offered by power electronics enabling the reduction of reactive power variations during the boring/melting periods.

However the disadvantages of this technology are the increased capital cost, due to the power electronic equipment, the harmonics generated by the power electronics and the high sensitivity of the arc to magnetic field generated by the feeder currents.

There are several design configurations for d.c. electric arc furnaces namely:

- **The Conventional Controlled Rectifier Bridge:** This is the simplest design with the typical P, Q diagram shown in figure 1-8.

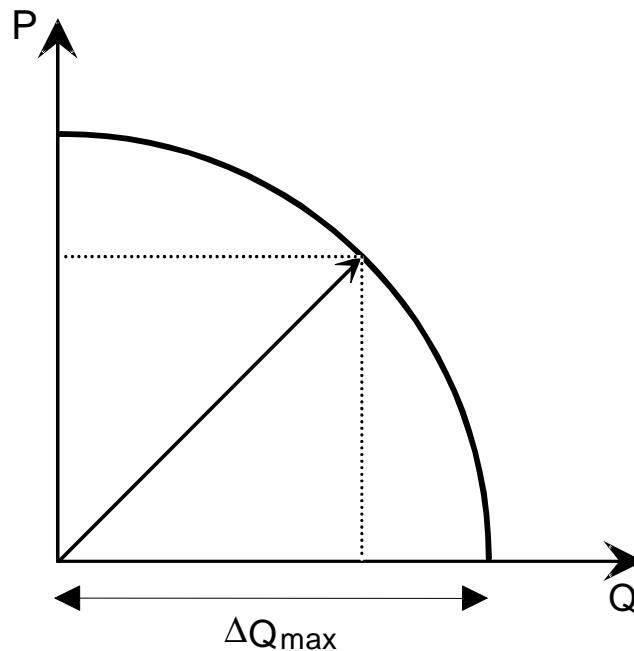

Figure 1.8: P, Q diagram of a d.c. electric arc furnace with simple controlled rectifier.

- **Controlled Rectifier Bridge with Free Wheeling Diodes:** This design reduces the reactive power consumption of the furnace when the rectifier output voltage low. However, there is no substantial reduction flicker generation.
- **Sequence Control of the Bridge Rectifier:** In this design the thyristors of the upper and of the lower branch in the same converter bridge are controlled separately. The firing angles are adjusted such as to keep the reactive power constant within a wide range of furnace operating conditions. Even during electrode short circuits, which occur frequently during melting of heavy scrap, the reactive power consumption remains constant.

- Free Wheeling Diodes plus Sequence Control:** The combination of a thyristor sequence control with free wheeling diodes as shown in Figure 1.9 can reduce the maximum reactive power. Moreover, the reactive power can be kept constant within a wide range. The reactive power decreases for low rectifier output voltage because of the free wheeling diodes. Therefore there is some reactive power fluctuation in case of electrode short circuit. The general scheme and the typical (P, Q) operating diagram of this a.c./d.c. converter configuration is shown in Figure 1.9 for a set of control principles or “Laws”.

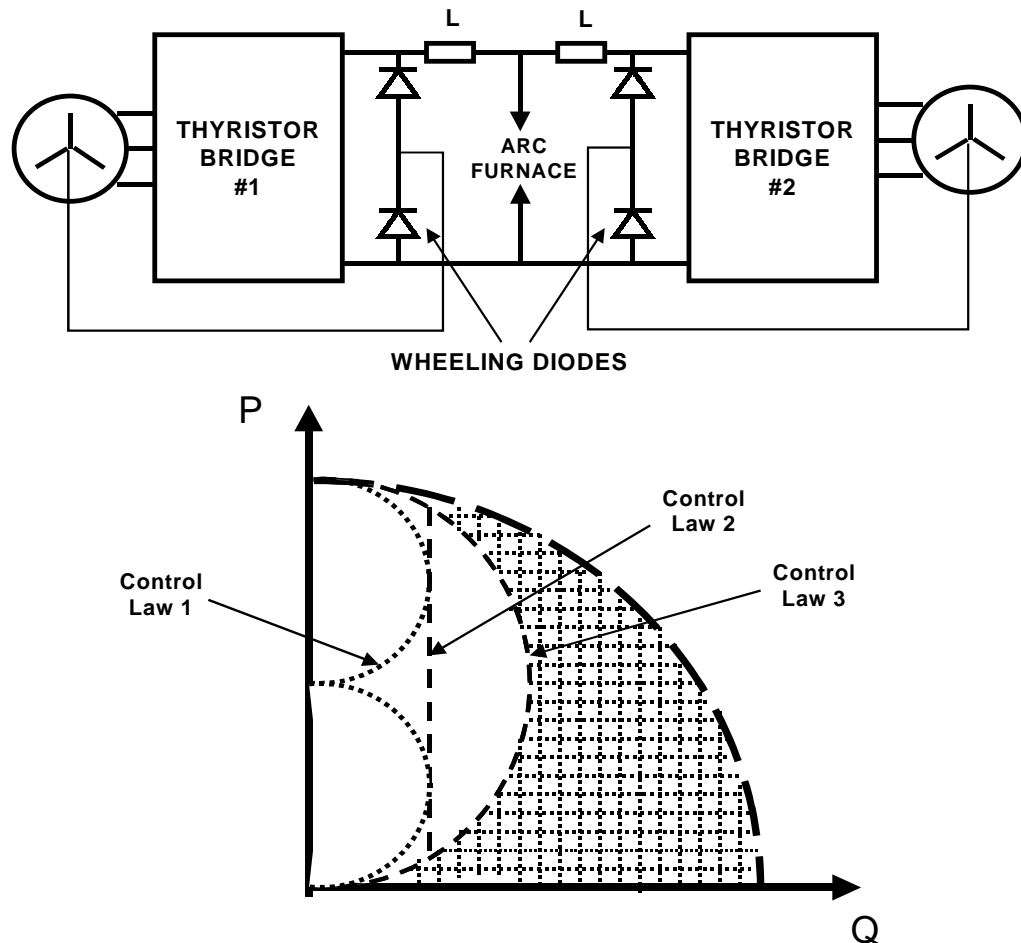

Figure 1.9: The P, Q diagram of a.c./d.c. converter with several possibilities of combined sequence control and free wheeling diodes.
 Control Law 1: minimum reactive power absorption operation;
 Control Law 2: minimum reactive power variation operation; and
 Control Law 3: freewheeling diodes and no sequence control.

In practice dynamic reactive compensation in the form of an SVC or STATCOM is also required for d.c. electric arc furnace installations. For example, in applications where there is a need to reduce the voltage drop or the flicker value or when overcompensation by the filter circuits is not acceptable variable compensation becomes essential. In such applications the input signals for the reactive compensation control can be taken from the potential and current transformers of the substation. As an alternative, signals from the rectifier control can be transmitted to the reactive compensation control to synchronise the d.c. furnace rectifier and reactive compensation controls. Such signals can be the rectifier firing angle, d.c. current and transformer tap position.

1.5 EFFICIENCY AND ECONOMIC BENEFITS OF COMPENSATION

1.5.1 Increased Production

The active power seen from the primary side of the furnace transformer (or primary side of the series reactor if present) can be expressed as:

$$P = \sqrt{S^2 - Q^2}$$

where S is the apparent and Q is the reactive power.

The apparent power is also equivalent to:

$$S = \sqrt{3} * I * U$$

where U is the voltage at the point where the furnace is connected. I is the furnace current.

The reactive power is equivalent to:

$$Q = 3 * I^2 * X$$

where X is the furnace reactance including transformer and series reactor.

The active power could also be expressed as follows:

$$P = \sqrt{S^2 - Q^2} = \sqrt{3(I * U)^2 - (3I^2 X)^2} = 3I^2 * \sqrt{\left(\frac{U}{\sqrt{3} * I}\right)^2 - X^2}$$

For a given current, the active power will increase for an increasing voltage in accordance with the above equation.

In order to maintain the efficiency of the arc furnace operation measures to maintain the power factor, additional reactance and/or increased arc furnace current have to be considered. The maintenance of operational power factor is important for maintaining the stability of the arc. In practice a power factor $\cos\phi=0.7$ or 0.8 is considered appropriate for this purpose.

The formula below shows that if the active power is increased, the reactive power also must be increased in order to achieve the same power factor.

$$\cos\phi = \frac{P}{\sqrt{P^2 + Q^2}}$$

The actual arc power increase obtainable due to an increased and stabilised voltage should be considered at the design stage to enable reasonably optimal dimensioning of the furnace and the power supply.

The calculated active and reactive power of an arc furnace installation incorporating a STATCOM for reactive compensation, is shown in Figure 1.10 below for various settings of the arc furnace transformer tap-changer without the STATCOM in operation.

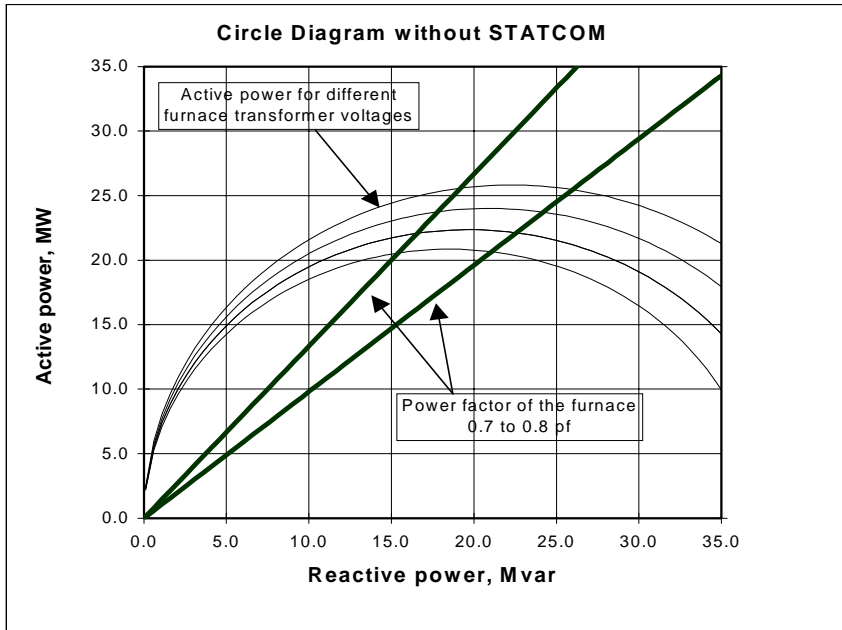

Figure 1.10: Calculated active power versus reactive power without the STATCOM in operation.

The same calculation results with the STATCOM in operation is shown in Figure 1.11 below.

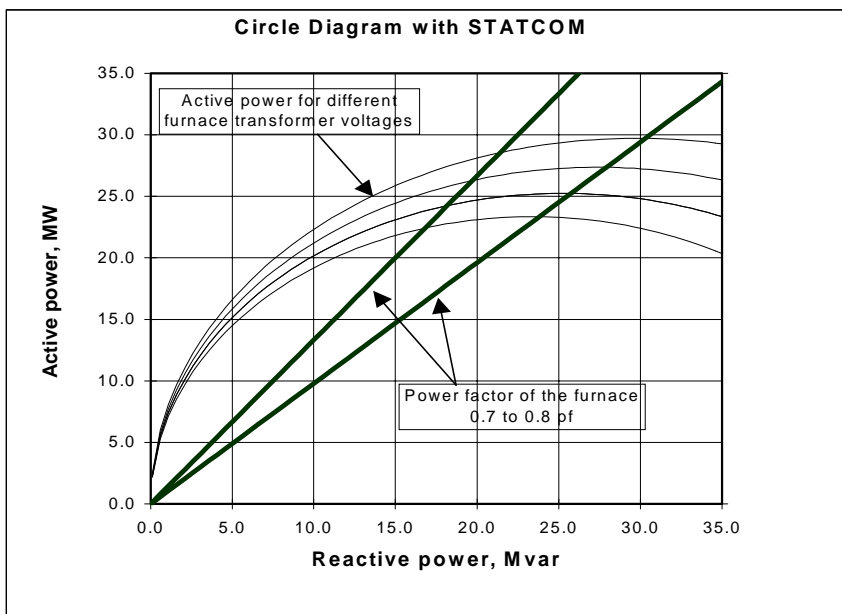

Figure 1.11: Calculated active power versus reactive power with the STATCOM in operation.

It is possible to obtain nearly the same increase in active power availability with an SVC, consisting of a TCR and filter circuits. Both the SVC and STATCOM can compensate the arc furnace reactive and unbalanced power components. However, the STATCOM due to its inherently faster response can achieve this objective much faster and with better accuracy. While this delivers increased active power availability, in practice, it also observed to lead to better arc stabilisation.

1.5.2 Advantages of Higher Active Power Availability

The prospects of utilising the increased power input in an existing (or refurbished) furnace, without the need to make changes to the existing furnace transformer and associated secondary installation, will inevitably vary between specific furnace installations and prevailing commercial considerations will have to be taken into account when evaluating such prospects. However, the use of increased furnace power and the shortening of the power on time in arc furnace operation is illustrated below.

An example of measured furnace active and reactive powers with and without STATCOM is shown in Figures 1.12 and 1.13.

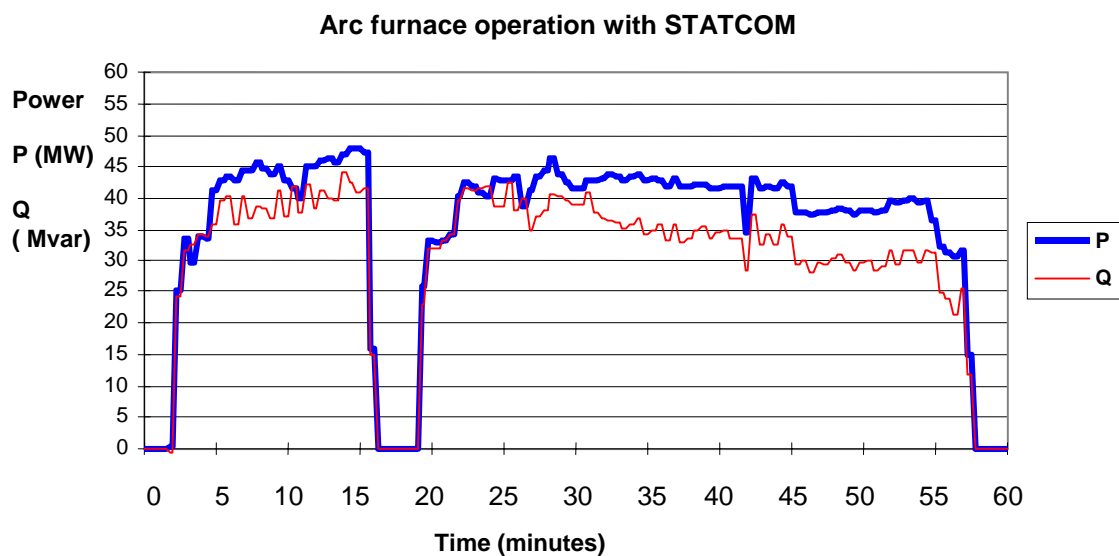

Figure 1.12: Measured arc furnace active and reactive powers with STATCOM in operation.

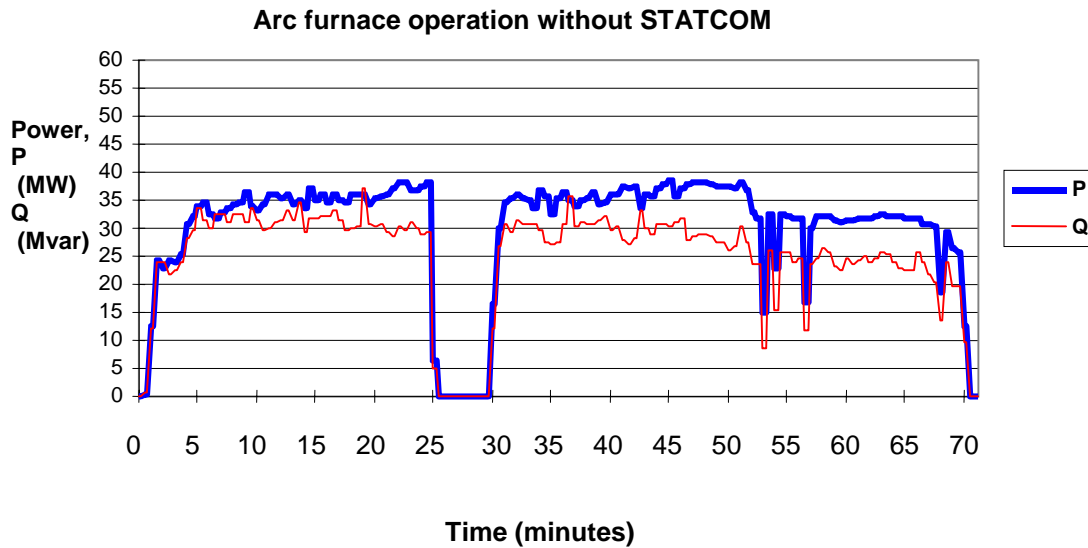

Figure 1.13: Measured arc furnace active and reactive powers without STATCOM in operation.

For this particular arc furnace installation the melt down time is around 66 minutes without the STATCOM in operation compared with 52 minutes melt down achieved with the STATCOM in operation.

Given increased melting power, the power on time of the furnace will be shortened. In practice the melt down time can be calculated by means of the following equation:

$$t_m = \frac{m_{liq}}{\eta_{scr}} \times \frac{W \times 60 \times 10^{-3}}{P \times f_{util}}$$

where,

- t_m = Melt down time
- m_{liq} = Charge weight, liquid steel
- η_{scr} = Yield factor, liquid/ scrap
- W = Energy consumption
- P = Rated active power
- f_{util} = Power utilisation factor (P_{mean}/P_{max}).

1.5.3 Energy Savings

Given the shorter operating time with a more stable arc, the losses in the furnace, as well as in the auxiliary systems (fans and pumps, etc.) will be decreased and energy savings of approximately 20 kWh/ton can be expected.

1.5.4 Electrode Savings

Due to the decreased power on time of the furnace the electrode consumption will also decrease. The consumption of graphite electrodes is mainly a result of side oxidation and tip wear. Typically, the graphite consumption in a modern a.c. arc furnace is around 2.5 to 4.0 kg/ton. The side oxidation is mainly a function of the power on time of the furnace. Shorter power on time of the furnace gives less electrode consumption per ton.

The tip consumption is a function of the electrode current. With a STATCOM, the arc voltage is stabilized and maintained at a high level. For the same melting power, the high arc voltage level gives possibilities to decrease the electrode current. In this way tip electrode savings will be achieved.

1.6 METHODS OF COMPENSATION

1.6.1 Reactive Compensation Approaches

In this section an indication of the mitigation techniques adopted to date to reduce flicker impact of arc furnaces are summarised.

- Increasing the short circuit power or the system fault infeed, by transferring the arc furnace connection to higher voltage level, if technically feasible. This solution can drastically reduce the level of disturbance but can require a significant investment for the connection.
- The installation of synchronous compensators to increase the short circuit power is no longer considered an option due to their high capital cost and maintenance requirements.
- Improvements to the metallurgical process, e.g. by utilising calibrated iron scrap in order to reduce the material collapse during the melting periods and thereby reducing the arc furnace current variations. Although many variations on this approach have been trialled this approach has not yielded a significant effect on the reduction of flicker [1-22].
- Adoption of compensating equipment and/or adoption of special control techniques.

In terms of the reactive compensation applications the following is a summary of the approaches that have been used in practical installations to date.

- **A.C. Passive Filters:** These filters consisting of passive resistive, inductive and capacitive components are installed to improve power factor and to reduce the harmonic impact. They are essentially ineffective against flicker due to their passive, i.e., non-dynamic nature, with their output varying only as a function of the square of the voltage. In fact under certain system operating conditions they are prone to create resonances at specific frequencies which can even increase the flicker level.
- **SVC:** This is the most common flicker reduction method utilised to date. In a typical installation the thyristor controlled reactor (TCR) is used combined with a.c filters. The rating of the SVC is approximately of the same order of the arc furnace rating and maximum achievable flicker reduction factor (expressed as the ratio between the P_{st} values without and with the compensating device) is in the order of two, at least with high power arc furnaces. The limitations of SVC in achieving higher values of flicker reduction factor are caused by the inherent time delay of the TCR and by the dynamic

interactions between the resonant a.c. filters of the SVC and the network. A formula for the rough estimation of the flicker reduction factor “FR_{SVC}” produced by an SVC, proposed in reference [1-19], is

$$FR_{SVC} \approx 1 + 0,75 (S_{SVC}/S_f)$$

where,

S_{SVC} is the rating of the SVC (TCR type) in MVA; and

S_f is the power rating of the arc furnace.

This formula may only be applicable to a maximum flicker reduction factor of 2, which represents, as mentioned before, the limit of flicker reduction achievable with an SVC type compensator.

- **Series Reactors:** The series reactors of a fixed reactance or variable stepped reactance, obtained through the use of a tap-changer, are inserted in series with the primary winding of the furnace transformer. The insertion of such a device increases the reactance of the furnace, stabilising the arc by increasing arc length and voltage and facilitates reduced electrode consumption. The adoption of an on-load tap-changer allows an optimisation of the reactance combined with the metallurgical process, adopting high values only in the most critical periods during melting.

However, it also causes operation at a lower power factor, drawing more reactive power and requires an increase in furnace transformer rating. As far as flicker reduction is concerned, at first sight there appears to be an advantage due to the increased electrical distance (reactance) between the furnace and the power system since the short circuit power of the arc furnace with respect to the system is reduced. However, in order to maintain the level of furnace productivity it is then necessary to increase the secondary voltage of the furnace transformer. This results in a substantially unmodified arc furnace short circuit power and in turn the flicker level remains practically unchanged [1-3].

- **Thyristor Controlled Series Reactor:** This method utilises a series reactor with a thyristor valve connected in parallel to it. The furnace operation can be improved through the control of the thyristor valve giving a vernier control inserting only the required proportion of the series reactor in line with the arc furnace conditions. In this way the reactive power changes can be reduced and the furnace currents balanced, resulting in better arc stability, lower flicker and less mechanical stress in the furnace.
- **Series Saturable Reactor:** This method involves insertion of a saturable reactor whose reactance can rapidly vary by varying its saturation level is inserted in series with the primary winding of the furnace transformer. The saturation level is controlled in such a way as to maintain the value the furnace current at a constant value as much as possible thus reducing the reactive power excursions.
- **Combined Series Reactor and SVC:** This combination brings together the previously discussed advantages of the two individual methods and could be attractive for applications where furnaces are connected to a relatively weak part of the power system.

- **Co-ordinated Control:** As previously discussed, in the case of d.c. arc furnaces, co-ordination between power electronics feeding the furnace and the reactive compensation devices can achieve both the flicker reduction and furnace efficiency objectives.

1.6.2 Reasons for Utilising STATCOM for Arc Furnace Compensation

The control principles of STATCOM designed for flicker reduction applications differs widely from the control principles of a STATCOM designed for a utility voltage support type application. The differences between these control principles will be described in the following chapters.

The following factors favour the utilisation of STATCOM devices for the compensation and reduction of arc furnace disturbances and flicker.

- STATCOM, due to its high rate of dynamic response, is able to reduce the flicker significantly better than an SVC of comparable rating. Whereas for an SVC the flicker reduction factor is limited to a maximum value of two, a STATCOM of the same rating yields a flicker reduction factor of at least four. In addition it is possible to obtain higher values flicker reduction by increasing the STATCOM rating whereas this is not possible with an SVC.
- Due to its inherent characteristic of a synchronous voltage source the STATCOM contributes to the system short circuit power or fault level at the point of connection and thus reduces the voltage fluctuations at that point.
- The increasing utilisation of arc furnaces for steel production, with adoption of very high power rating and utilisation characteristics, i.e., higher number of daily melting cycles, increases the flicker impact of the furnace on neighbouring customers. This then necessitates the use of compensation devices, which can yield better flicker reduction performance and higher flicker reduction factors.
- The tendency to utilise arc furnaces of higher power rating and utilisation factor is not usually matched by a corresponding increase in the short circuit power or fault level of a.c. power systems to which the furnace will be connected. This in turn increases the impact profile of the arc furnace on both the utility and the neighbouring customers. This influences the functional specification of compensation as modern utilities are increasingly subject to regulatory scrutiny and targets for power quality.
- The limits in the flicker reduction performance of traditionally utilised equipment and SVC's, with the maximum flicker reduction factor obtainable being in the order of two, is unlikely to be sufficient in many applications especially those with high furnace ratings. The inherent limitations of SVC's mean that it is not possible to obtain further flicker reduction performance improvements by increasing the SVC rating or utilising multiple SVC installations at the same location.
- The STATCOM offers additional advantages in terms of very much smaller harmonic generation and in terms of its smaller overall physical size and footprint.

1.7 REFERENCES

- [1-1] “Guide to Quality of Electrical Supply for Industrial Installations – Part 5: Flicker and Voltage Fluctuations”, UIE Power Quality WG 2, 1999.
- [1-2] T.S. Key, N. Lizanich, D. J. Nastasi and M. Sakulin “International Standards Limiting Voltage Fluctuations and Objectionable Light Flicker”, PQA 97, Stockholm.
- [1-3] A.Robert and M. Couvreur “Arc Furnace Flicker Assessment and Prediction ” Paper 2.02, CIRED 1993 Conference.
- [1-4] IEC 61000-2-1 Electromagnetic Compatibility, Part 2 Environment, Section 1: Description of the Environment – Electromagnetic Environment for Low-Frequency Conducted Disturbances and Signalling in Public Power Supply Systems, May 1990, Technical Report Type 3.
- [1-5] IEC 61000-2-2 Electromagnetic Compatibility, Part 2 Environment, Section 2: Compatibility Levels for Low-Frequency Conducted Disturbances and Signalling in Public Low-Voltage Power Supply Systems, May 1990.
- [1-6] IEC 61000-2-2, Ed 2 Electromagnetic Compatibility, Part 2-2: Environment - Compatibility Levels for Low-Frequency Conducted Disturbances and Signalling in Public Low-Voltage Power Supply Systems, IEC 77A/324/CDV, September 2000.
- [1-7] IEC 61000-2-12, Ed 1 Electromagnetic Compatibility, Part 2-12: Environment - Compatibility Levels for Low-Frequency Conducted Disturbances and Signalling in Public Medium-Voltage Power Supply Systems, IEC 77A/321/NP, August 2000.
- [1-8] IEC 61000-4-15 Electromagnetic Compatibility, Part 4, Section 15 Testing and Measurement Techniques: Flickermeter – Functional and Design Specifications, November 1997.
- [1-9] UIE Guide on “Flicker Measurement and Evaluation, 1992.
- [1-10] IEC 61000-4-15 A1 Ed. 1 Amendment to Add Specifications for Flickermeters for 120 V Systems and More Closely Define the Specification of a Filter in the Instrument According to Standard IEC 61000-4-15, IEC 77A/341/CDV, June 2001.
- [1-11] IEC 61000-3-3 Electromagnetic Compatibility, Part 3-11 Limits: Limitation of Voltage Changes, Voltage Fluctuations and Flicker in Public Low-Voltage Supply Systems - Equipment with Rated Current ≤ 75 A and Subject to Conditional Connection, August 2000. IEC 61000-3-3-amendment 1, January 2001.
- [1-12] IEC 61000-3-11 Electromagnetic Compatibility, Part 3 Limits, Section 3: Limitation of Voltage Changes, Voltage Fluctuations and Flicker in Public Low-Voltage Supply Systems - Equipment with Rated Current ≤ 75 A and Subject to Conditional Connection, August 2000.
- [1-13] IEC 61000-3-7 Electromagnetic Compatibility, Part 3 Limits, Section 7: Assessment of Emission Limits for Fluctuating Loads in MV and HV Power Systems, October 1996, Technical Report - Type 3.
- [1-14] A.Robert and M. Couvreur “Recent Experience of Connection of Big Arc Furnaces with Reference to Flicker Level” Paper 36-305, CIGRE 1994 Session.
- [1-15] E. De Jaeger “Measurement and Evaluation of the Flicker Emission Level from a Particular Fluctuating Load”, CIGRE/CIRED WG CC02 internal document, n. 9810
- [1-16] CENELEC EN 50160 2nd Edition “Voltage characteristics of electricity supplied by public distribution systems”, November 1999.
- [1-17] IEEE/ANSI Standard 141-1993 “Recommended Practice for Electric Power Distribution for Industrial Plants.

- [1-18] IEEE Standard 519-1992 “Recommended Practice and Requirements for Harmonic Control in Electric Power Systems”, April 1993.
- [1-19] M. Aoki “Standard Method for Measurement of Voltage Fluctuations”, 9th International Congress of UIE, Cannes (France) 1980.
- [1-20] E. Kuba, K. Terashima and K. Okazaki “Grasping the meaning of voltage flicker on a.c. electric arc furnaces ”, XII UIE Congress, Montreal, Canada 1992.
- [1-21] WG Disturbances of UIE “Flicker Measurement and Evaluation, Second revised edition”, 1991.
- [1-22] L. Bisiach, I. Campestrini and C. Malaguti “Technical and Operational Experiences for Mitigating Interferences from High capacity Arc Furnaces”, Paper 36-204, CIGRE 1992 Session.
- [1-23] D. Arlt and C. Eberlein “Network Disturbances Caused by Ultra High Power Electric Arc Furnaces and Possible Reduction Method”, 4th International Conference, Electrical Power Quality and Utilisation, September 23-25, 1997, Cracow, Poland.
- [1-24] Test Protocol for Testing and Calibrating Flickermeters. Document in preparation by CIGRE/CIRE Working Group CC02.

Chapter 2 STATCOM COMPENSATION APPROACHES

Prepared by Laszlo Gyugyi

2.1 ELECTRICAL CHARACTERISTICS OF THE ARC FURNACE LOAD

As described in Chapter 1, the electric arc furnace presents, particularly during the initial melt down period of operation, a rapidly varying, generally unbalanced and “non-linear” load with relatively low and lagging power factor. The large and erratic swings of the real and reactive load current components, together with the harmonic and other extrabasal (non-integrally related) current components, cause corresponding voltage variations across the (largely reactive) impedance of the a.c. supply network, resulting in fluctuating terminal voltage with appreciable distortion and possible unbalance. If residential and other industrial and commercial customers are also supplied by the same a.c. network, the fluctuating and distorted system voltage may cause variations in the light output of electrical lamps (“flicker”) and disturbances in television sets, computers and other industrial and telecommunication equipment.

The arc furnace load and its effect on the supply system are illustrated in Figures 2.1 (in compressed time scale) and 2.2 (in expanded time scale), where the a.c. line currents, i_a , i_b , i_c , and the corresponding real and reactive power, P_F and Q_F , drawn during the melt down period by a 60 MVA (90 ton) furnace from a 34 kV distribution line, represented by line to neutral voltages v_a , v_b , v_c , are shown. The bottom traces of both figures show on a 10 times expanded scale, the variation of these voltages. In these figures, the erratic fluctuation of the real and reactive power, the distortion of the line currents, the apparent unbalance of the load (particularly manifested by the 2nd harmonic ripple on the power plots in Figure 2.2), and the corresponding variations of the 34 kV bus voltage are clearly observable.

The behaviour of the furnace load is due to the physical nature of arc itself. The electric arc is an electrical discharge in a gas, in the present case, current flowing in an ionised gas between the furnace electrodes and the charge. The arc is characterised by a non-linear impedance (the resistance of the arc exponentially decreases with current), resulting in relatively constant (and low) arc voltage (and high arc current). In the case of the a.c. arc furnace, the electrodes alternatively become cathodes (during negative voltage periods) and anodes (during positive voltage periods). Thus, the arc is extinguished at each current zero. At that time, the voltage between the electrode tip and the charge becomes equal to that of the supply voltage at the secondary winding of the furnace transformer. Depending on the overall power factor of the total arc furnace circuit, this voltage may or may not be sufficiently high to re-ignite the arc. At relatively high power factor, the voltage at the instant of current zero is too small to re-ignite the arc. Thus, as illustrated in Figure 2.3, the current remains zero until the voltage reaches a sufficient magnitude for re-ignition. These zero current intervals between successive positive and negative current half cycles can also be observed in the current plots of Figure 2.2. With lower overall circuit power factor, the voltage can be made sufficiently high for immediate re-ignition of the arc following the instants of current zero to yield a continuous current and more stable arc. The maintenance of arc stability is generally a difficult problem, particularly during the initial bore-down period of the melting cycle due to scrap movement. Arc movements are also caused by electro-magnetic forces. The arc length and stability thus influences significantly the flicker,

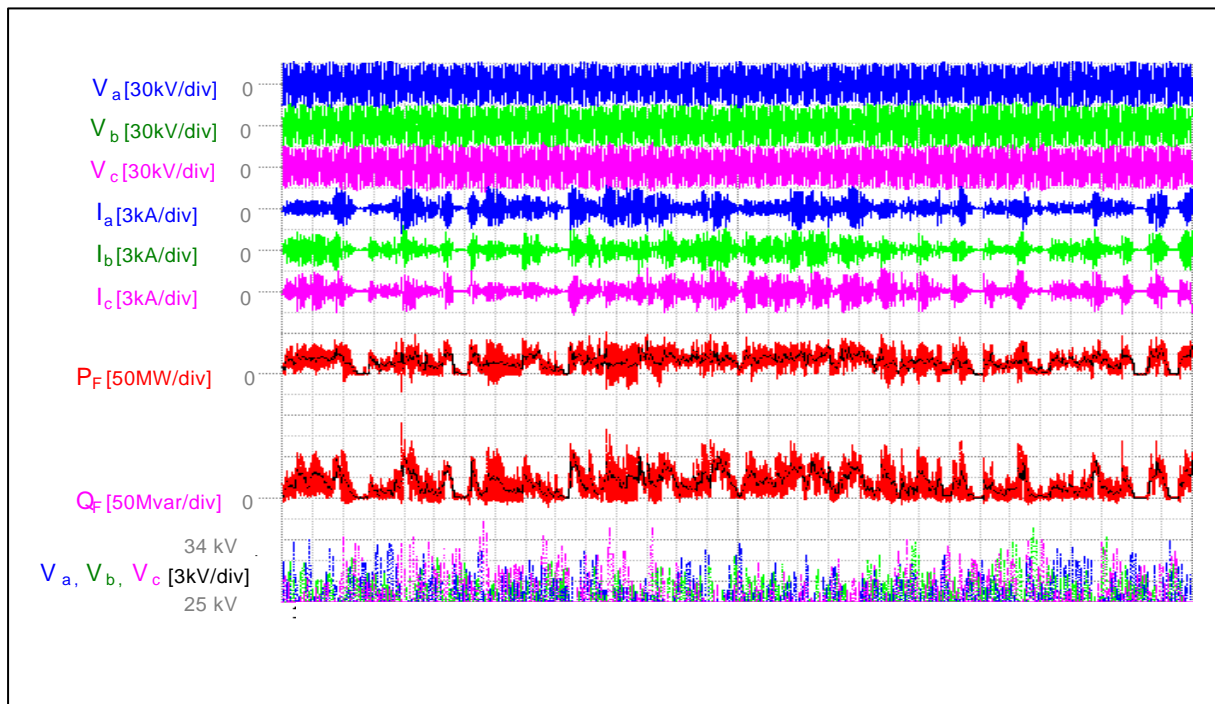

Figure 2.1 Fluctuation of supply voltage, current, real and reactive power during the melt down operation of a 60MVA (90ton) arc furnace (compressed time scale).

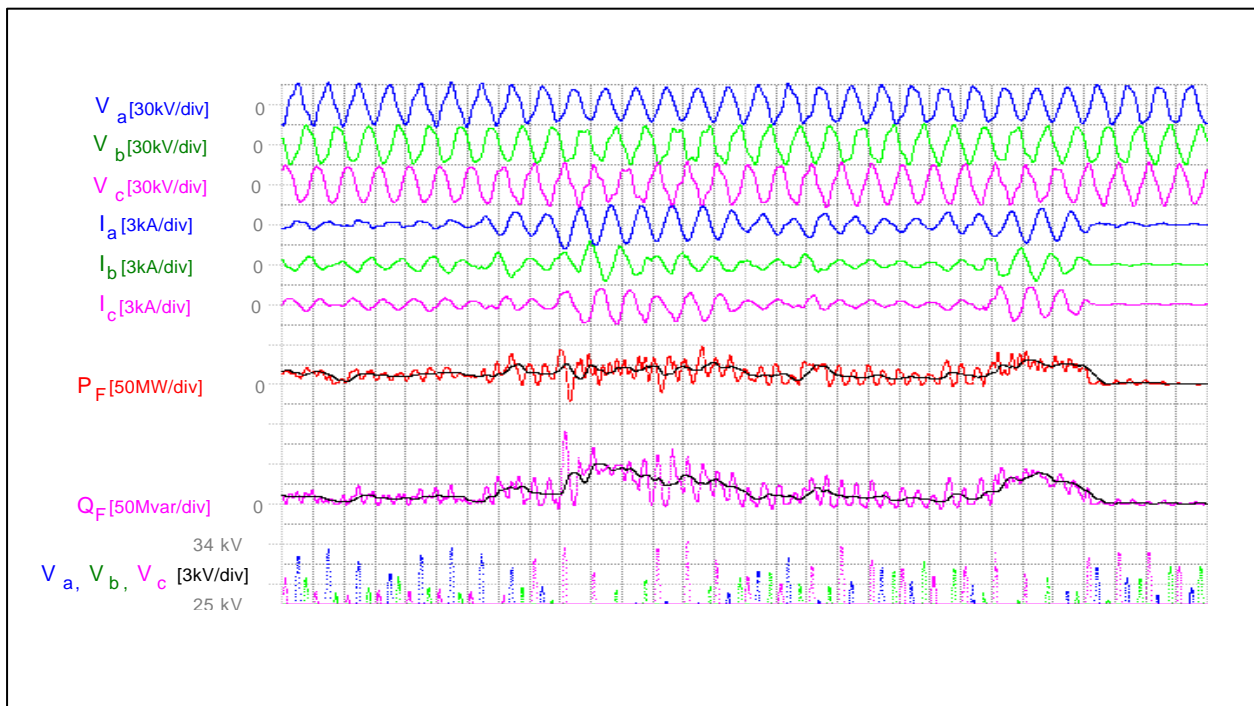

Figure 2.2 Fluctuation of supply voltage, current, real and reactive power during the melt down operation of a 60MVA arc furnace (expanded time scale).

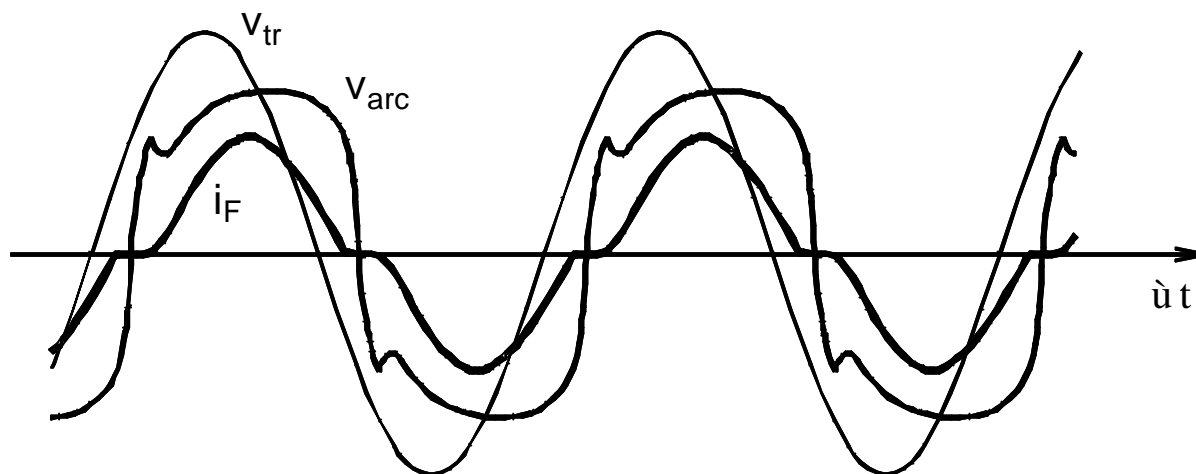

Figure 2.3 Arc furnace transformer secondary voltage (V_{tr}), arc voltage (V_{arc}) and furnace current (i_F).

harmonic generation, and other electrical disturbances, as well as the production output, electrode consumption and furnace wear. All these can be influenced by the arc length, overall circuit impedance, operating voltage and power, as well the operating practice followed. These factors are the elements of difficult design trade-off and operational procedures in an attempt to maximise production output and minimise electrode consumption, furnace wear as well as flicker and harmonic generation.

2.2 COMPENSATION REQUIREMENTS [2-1, 2-2]

Ignoring the harmonic generation, the compensation requirements of an a.c. electric arc furnace, shown schematically with the power supply system in Figure 2.4a, can be established with the aid of a relatively simple linear model. In this model, the arc furnace is substituted by three fixed reactors, each in series with an independently variable resistor, as shown in Figure 2.4b.

The reactors represent the furnace transformer leakage and cable inductances, the variable resistors the arc resistances. All quantities are referred to the substation bus. At a given instant of time, the arc furnace draws current i_{Fa} from phase *a*, i_{Fb} from phase *b*, and i_{Fc} from phase *c* which, particularly during the melt-down period, form an unbalanced set of currents, usually with different amplitudes and phase angles. At subsequent instants of time, the three line currents would generally be different due to the three continually changing arc resistances in the furnace. Thus the magnitudes and relative angles of the three arc furnace currents would continually change, producing fluctuating real and reactive power demand with a varying degree of unbalance on the a.c. supply system. Thus, in arc furnace applications, the basic compensation must address the magnitude variation, power factor and balance of the load currents.

In order to investigate the compensation requirements, it is necessary to consider the linear arc furnace model shown in Figure 2.4b. If we initially assume that the arc furnace presents a cyclically varying balanced load, i.e., the three resistors, representing the three arc resistances, vary together then the three resultant arc furnace currents vary similarly and the required compensation in each phase will be the same. Therefore, initially it is sufficient to consider one of the three phases, say phase *a*, of the a.c. system.

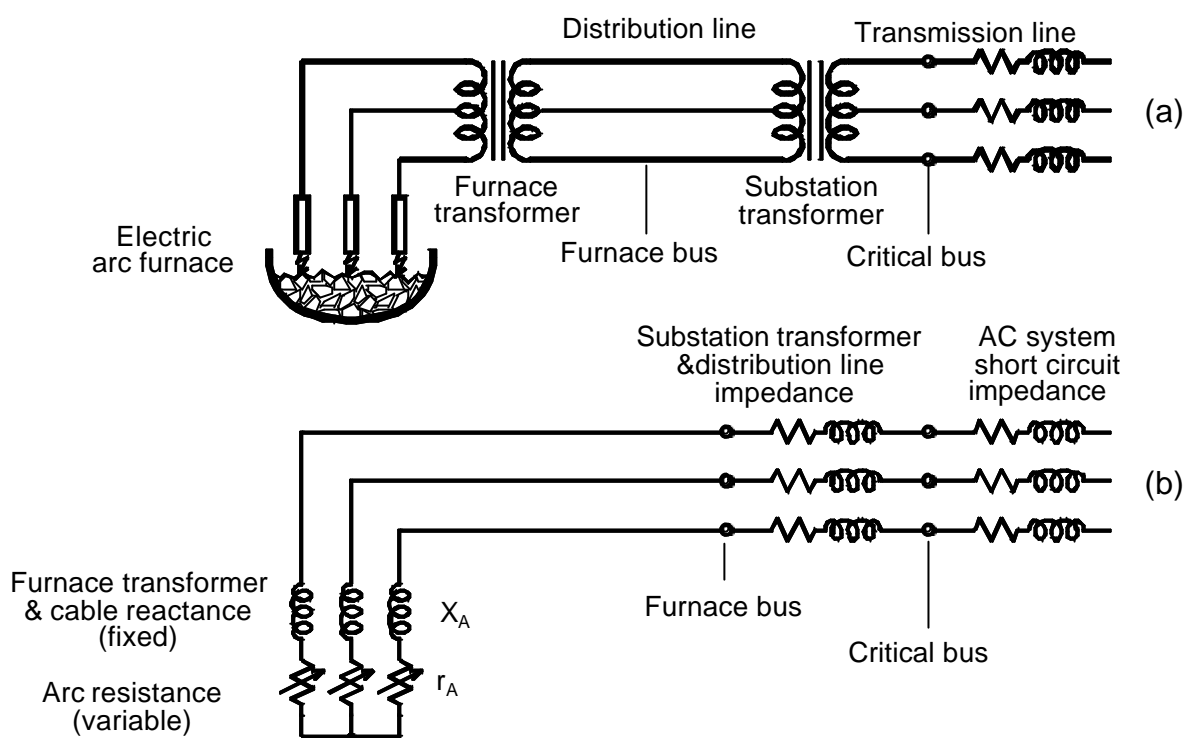

Figure 2.4 Schematic representation (a) and linearised equivalent circuit of the a.c. power system and the arc furnace load (b).

The current drawn by the arc furnace from, for example, phase *a* can be represented by phasor I_F drawn in the rectangular co-ordinate system of real (horizontal) axis I_r and reactive (vertical) axis I_q . The tip of vector I_F follows a semicircle as the arc resistance is varied from zero (short circuit) to infinity (open circuit) as illustrated in Figure 2.5(a). The radius of the circle is defined by the maximum real component of the arc furnace current (which, with the linear circuit considered, is equal to half of the maximum reactive component of current). It can be observed in the figure that a relatively small variation of the arc furnace current, for example, a $\pm 20\%$ amplitude change around the nominal 1.0 p.u. value of I_F , obtained at 0.71 power factor, results in a large change in the reactive current component. That is, the magnitude I_q of the reactive current component swings from the nominal 0.71 p.u. down to 0.46 p.u. at $I_F = 0.8$ p.u. and up to 1.02 p.u. at $I_F = 1.2$ p.u. At the same time, the magnitude I_r of the real current component hardly changes at all, it

decreases from 0.71 p.u. to 0.63 p.u. and to 0.66 p.u., respectively. At larger variation of I_F , e.g., when $0.65 \leq I_F \leq 1.35$, the fluctuation of the real current component with that of the reactive current becomes more pronounced, as indicated in the Figure 2.5(a). It is also observable that the reactive component of the furnace current can ultimately vary in the theoretical range of $0.0 \leq I_q \leq 2.0$, and the real component in the range of $0.0 \leq I_r \leq 1.0$.

Consider now unbalanced furnace operation with the same boundaries as before; that is, the arc resistances can vary between the limits, which correspond to 0.8 p.u. and 1.2 p.u., or to 0.65 p.u. and 1.35 p.u., balanced current variations. However, the three arc resistances are allowed to take any value individually between these limits. For example, initially all three resistances at operating point 1 are equal and minimum: $r_{Aa} = r_{Ab} = r_{Ac} = r_{Amin}$. Then, as transiting to operating point 2, r_{Ac} is increased to maximum so that operating point 3 is characterised by: $r_{Aa} = r_{Ab} = r_{Amin}$ and $r_{Ac} = r_{Amax}$. Subsequently, as transiting to operating point 2, r_{Aa} is also increased to maximum, and so on, as the tabulation below shows the assumed arc resistances at the six operating points considered. Further information on arc furnace operational states is given in Appendix A.

Operating Point	r_{Aa}	r_{Ab}	r_{Ac}
1	r_{Amin}	r_{Amin}	r_{Amin}
2	r_{Amin}	r_{Amin}	r_{Amax}
3	r_{Amax}	r_{Amin}	r_{Amax}
4	r_{Amax}	r_{Amax}	r_{Amax}
5	r_{Amax}	r_{Amax}	r_{Amin}
6	r_{Amin}	r_{Amax}	r_{Amin}

The corresponding arc furnace current plots for two sets of r_{Amin} and r_{Amax} values, which, under balanced conditions, result in $I_{Fmax} = 1.2$ p.u. and $I_{Fmin} = 0.8$ p.u. and in $I_{Fmax} = 1.35$ p.u. and $I_{Fmin} = 0.65$ p.u., are shown for phase a in Figure 2.5(b). It should be noted that in this figure the operating points for the latter case are identified by bold numbers.

Comparing the plots in Figure 2.5 (a) and (b) the first noticeable difference between unbalanced and balanced arc furnace operation is that, in the unbalanced case, the arc furnace current phasor does not describe a semi-circle, but it defines the boundary of an area. The other difference is that, depending on the arc resistance in the other phases, the arc furnace current can be larger under unbalanced conditions than under balanced ones with the same minimum arc resistance limit. This is observable by comparing the balanced operating point 1 with the unbalanced operating point 2 in the figure. This suggests that the compensation requirements under unbalanced conditions may primarily determine the current rating of the compensator, although the MVA rating would be the largest under worst case balanced conditions, as the three-phase arc furnace plot in Figure 2.6, showing the three balanced phasors corresponding to operating point 1 in phase a , indicates.

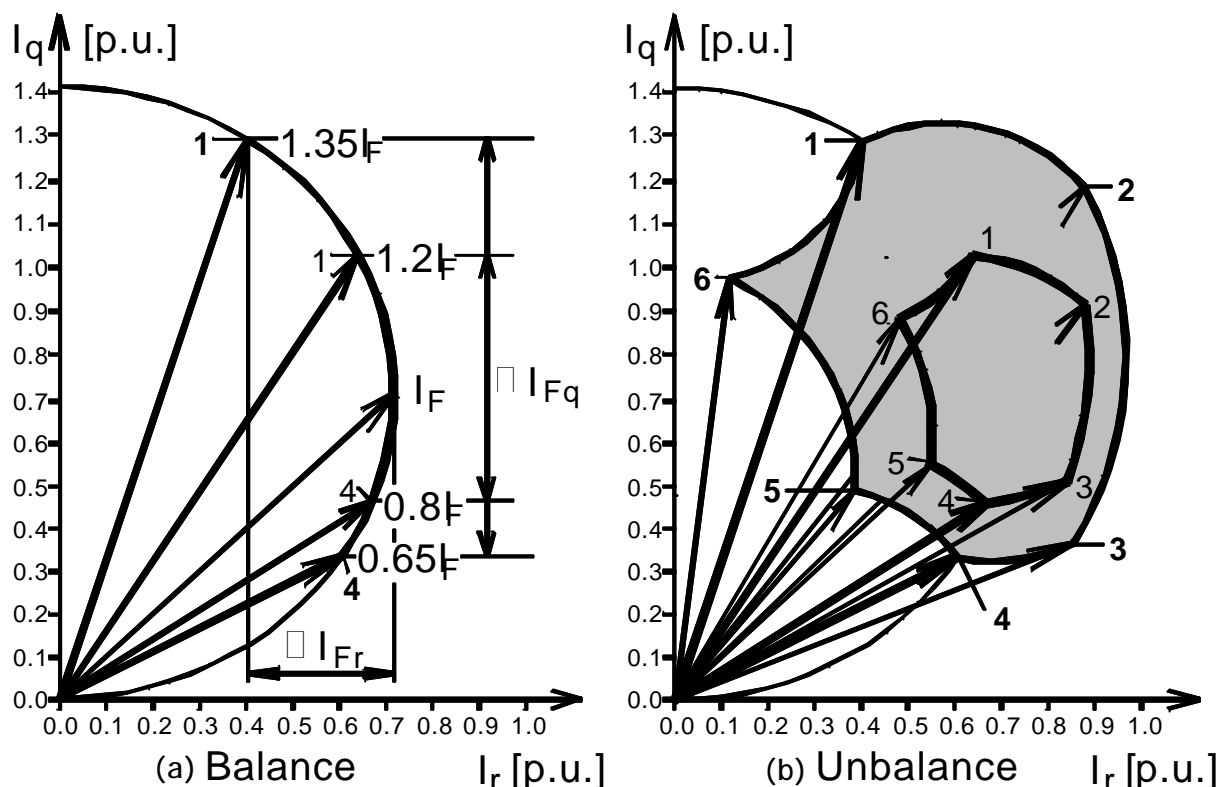

Figure 2.5 Variations of arc furnace phase current under balanced (a) and unbalanced (b) conditions.

The unbalanced furnace current phasors, I_{Fa} , I_{Fb} , and I_{Fc} , and the corresponding time functions, i_{Fa} , i_{Fb} , and i_{Fc} , representing operating point 2 in Figures 2.5 and 2.6, are shown together in Figure 2.7. In order to establish a qualitative measure of the unbalance and formulate the compensation requirements, it is convenient to decompose the set of unbalanced currents into two sets of balanced currents, one with positive the other with negative phase sequence. This decomposition is illustrated in Figure 2.8, where the positive sequence components, I_{1Fa} , I_{1Fb} , and I_{1Fc} , and the negative sequence components, I_{2Fa} , I_{2Fb} , and I_{2Fc} , of the unbalanced current phasor set, I_{Fa} , I_{Fb} , and I_{Fc} , are shown together with the corresponding positive sequence and negative sequence time functions, i_{1Fa} , i_{1Fb} , i_{1Fc} and i_{2Fa} , i_{2Fb} , i_{2Fc} , respectively.

The above decomposition of the furnace current into a balanced set of positive and a balanced set of negative sequence components is based on the tacit assumption of a steady-state condition. The arc furnace, particularly during the melt-down period, is of course not in a steady-state. Consequently, the actual operating point of the arc furnace in the operating current domain of the $\{I_q; I_r\}$ plane would generally vary from one instant to another in the area the boundary of which is defined by the minimum and maximum arc resistances. However, assuming a time scale with discrete incremental changes, the arc furnace current may be viewed as a set of steady-state currents given at discrete time instants when measurements (samplings) are taken. If the time instants are appropriately close to each other, the time varying currents can be reconstructed from

a series of measured “steady-state” currents, in the same way as a chain of still pictures can faithfully describe a moving object.

With this view, and with reference to Figure 2.8, the basic compensation requirements of the arc furnace load, for each discrete instant of time, can generally be stated as follows:

- (1) The magnitude of the reactive component of the positive sequence current must be zero or constant, that is, $I_{IFq} = 0$ or $I_{IFq} = \text{constant}$.
- (2) The negative sequence current must be zero, that is, $I_{2F} = 0$.

Note:

[min,min,max] [r_{Aa,min}; r_{Ab,min}; r_{Ab,min}]

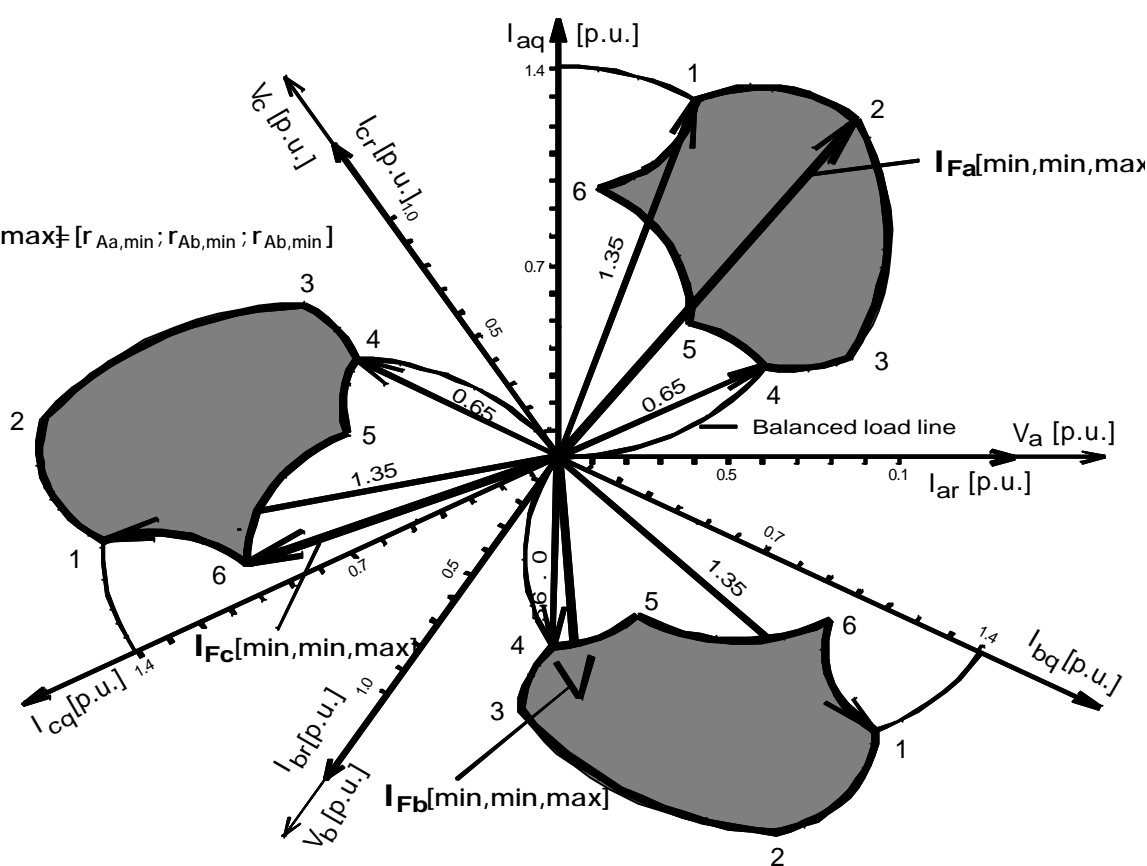

Figure 2.6 Operating areas of the arc furnace currents for the arc resistance range that corresponds to 0.65 to 1.35 p.u. current magnitude change under balanced operating conditions.

Ignoring the harmonic and extrabasal current components produced by the arc furnace load, a compensation meeting the above requirements in each successive discrete time instant close enough to faithfully represent all unwanted current components in the frequency band associated with visual flicker, could reduce the terminal voltage variation to practically acceptable level. These requirements can be satisfied by a controllable, purely reactive compensator with sufficient speed of response. However, it should be evident that even a perfect reactive compensator, fully

rated to meet the above conditions without restriction in the total arc resistance range of $0 \neq r_A \neq 4$, would be neutral to the fluctuation of the real component of the positive sequence arc furnace current. In other words, the fluctuation of the real power consumed by the arc furnace would not be compensated.

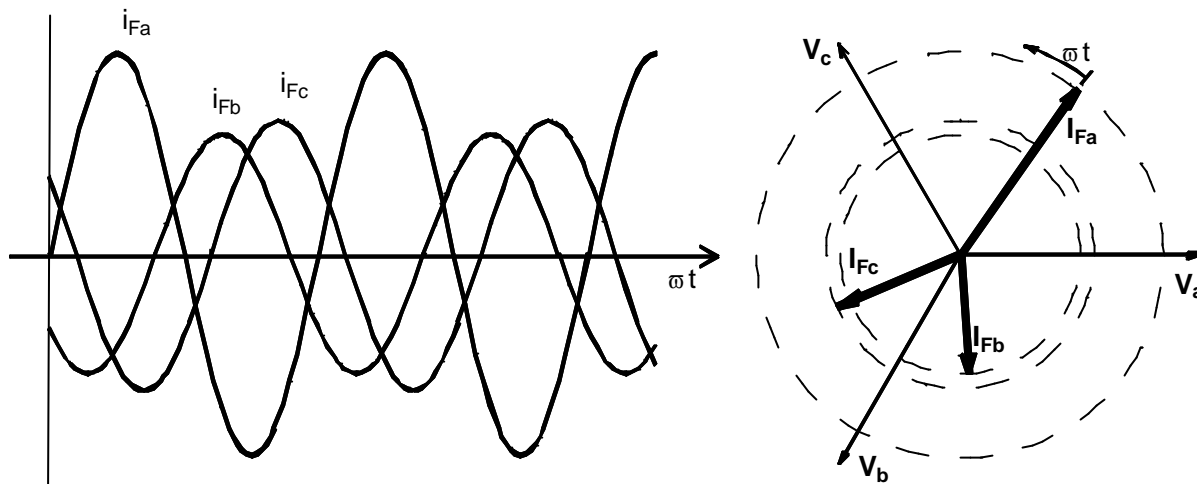

Figure 2.7 Unbalanced phasor furnace current set \mathbf{I}_{Fa} , \mathbf{I}_{Fb} , and \mathbf{I}_{Fc} , and the corresponding time functions, representing operating condition 2 (with $I_{Fmax,bal} = 1.35$ p.u. and $I_{Fmin,bal} = 0.65$ p.u.).

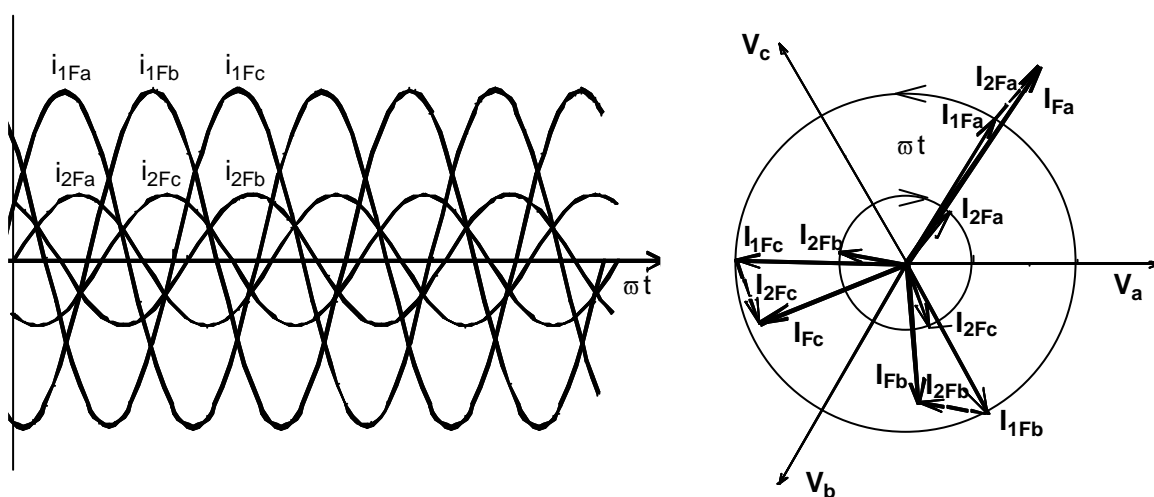

Figure 2.8 Decomposition of unbalanced phasor furnace current set \mathbf{I}_{Fa} , \mathbf{I}_{Fb} , and \mathbf{I}_{Fc} into positive sequence (\mathbf{I}_{1Fa} , \mathbf{I}_{1Fb} , and \mathbf{I}_{1Fc}) and negative sequence (\mathbf{I}_{2Fa} , \mathbf{I}_{2Fb} , and \mathbf{I}_{2Fc}) symmetrical components.

The fluctuating real current would cause a corresponding voltage variation across the largely reactive system impedance that is in quadrature with the fundamental system voltage making the resultant terminal voltage to vary both in magnitude and angle. The magnitude variation is generally small and only in a few cases may cause objectionable disturbances. However, the relatively large real power fluctuation with the corresponding angular changes may, in some cases, cause torsional interactions with nearby turbine generators. The solution of these problems would require a capability to eliminate or minimise the fluctuation of real power that the purely reactive compensator does not have. However, a converter based compensator (STATCOM), functioning as a static generator with the capabilities of both generating reactive power for and exchanging real power with the a.c. system, can provide both the necessary reactive compensation to eliminate or reduce reactive power demand, balance the load, and minimise the real power fluctuation. Thus, an auxiliary requirement for ideal arc furnace compensation can be formulated:

- (3) The real power fluctuation over a defined interval of time must be zero, or the real power absorbed over a defined time interval from the a.c. system must be constant. That is, $p_{Fr} = P_{Fr}$ for $t_x \# t \# t_x + \Delta t$, where t_x is an instant of time and Δt is an interval of time the length of which could be a function of the instantaneous furnace power p_{Fr} .

The ideal compensation requirement (3) can be approximated in practice by averaging for the a.c. system the real power demand of the arc furnace over a (possibly varying) period of time. This necessitates the compensator to draw real power from the a.c. system into and appropriate energy storage when the furnace load is low, and supply real power to it when the furnace load is high. Since the compensator, like a rotating generator, is not a source, but a converter of electric power, the power averaging must result in zero net energy. For this reason, real power fluctuation in practice cannot be totally eliminated but, in general, it can be reduced sufficiently in magnitude and altered in frequency to make its effect on the a.c. system negligible.

The requirements stated in (1), (2), and (3) imply the intent of perfect compensation (except for the harmonics being ignored). Such a compensation in practical applications would not normally be required and could be too expensive to afford due to the large MVA rating of the compensator needed. However, the above stated compensation requirements can be universally used by restricting its application to a chosen operating area of the arc furnace, such as defined in Figure 2.5(b) for the arc furnace current variation in the $\{I_q ; I_r\}$ plane with the stipulated values of maximum and minimum arc resistance ($r_{Amin} \# r_A \# r_{Amax}$). Clearly, the smaller this area, the lesser portion of the actual furnace current variation will be compensated, and the higher the resultant terminal voltage fluctuation will be. By the same token, the larger this area, the greater portion of the actual furnace current variation will be compensated, and the lower the resultant terminal voltage fluctuation will be. With the maximum possible operating area ($0 \# r_A \# 4$), all furnace current variation would be compensated and, assuming an ideal compensator with instantaneous response, the terminal voltage variation would be zero. Of course, as shown in Figure 2.5, as the compensation is extended to larger furnace current variations, the required MVA rating (and cost) of the compensator will proportionally grow. Thus, in order to establish the proper MVA rating of the compensator for specific practical applications, it is crucially important to define the amount of compensation needed on the basis of arc furnace rating, network impedance, operating practice and allowed flicker, pertinent to the case considered. However, it is also important to understand that rating calculations are based on assumptions and statistical predictions, which may not be

fully valid, or could change in time, for a given furnace. Therefore, it is normally a prudent practice to provide a judicious (if not generous) margin for the required MVA rating, since the rectification of insufficient flicker reduction could require much more expensive measures in operating restrictions of the furnace, or in additional equipment, than the incremental cost increase of the compensator with a somewhat higher rating would be. The specific issues related to the rating of the compensator are discussed in the later Chapters.

The compensation requirements of the arc furnace also includes the reduction of the non-fundamental (i.e., harmonic and extrabasal) current components. In conventional compensators, harmonic attenuation is addressed by passive LC shunt filters tuned to specific harmonics. However, such filtering generally amplifies the extrabasal components whose frequencies lie between the harmonic components. These components can aggravate the flicker problem, particularly for fluorescent and similar gas discharged lamps. As will be seen, the converter-based compensator (STATCOM), depending on the design, may be able to provide the necessary attenuation both for the dominant harmonic and extrabasal components, electronically, by control means, without any, or just with relatively small, passive filter(s).

2.3 VECTOR REPRESENTATION OF ELECTRICAL VARIABLES [2-3]

The rapidly varying arc furnace load requires extremely fast, sub-cycle response from the compensator. The sub-cycle operating time frame mandates the controlled outputs of the compensator, reactive and real power, to be defined on an instantaneous basis. The vector representation of instantaneous variables of the arc furnace load, currents and voltages, is particularly suitable for acquiring and processing the necessary information in a digital form to determine the instantaneous compensation requirements of the arc furnace.

The term vector, instead of phasor, is used to represent a set of three instantaneous phase variables, voltages or currents, that sum to zero. The symbols \vec{v} and \vec{i} are used for voltage and current vectors. A vector at a given time instant is defined by the corresponding instantaneous values of the three phase variables given on three symmetrically disposed phase-axes in a plane. The vector is drawn from the origin of the three phase-axes to the point whose vertical projections onto each of the three axes coincides with the instantaneous value of the corresponding phase variable, as illustrated in Figure 2.9. At (a), the three balanced arc furnace currents, i_{Fa} , i_{Fb} , and i_{Fc} , corresponding to operating point 1 in Figures 2.5 and 2.6, as functions of ωt are shown. At (b), the vector $\vec{i}_{F,0E}$, corresponding to the three instantaneous values, at $\omega t=0E$, of i_{Fa} , i_{Fb} , and i_{Fc} on the respective i_a , i_b , and i_c axes, is shown. (In this, and in the subsequent figures, the three voltage axes indicating the phase positions of the respective three supply voltages, v_a , v_b , and v_c , are also shown by dashed-lines for reference.) At (c), the vector $\vec{i}_{F,40E}$, corresponding to the three instantaneous values, at the instant $\omega t=40E$, of i_{Fa} , i_{Fb} , and i_{Fc} on the respective i_a , i_b , and i_c axes, is shown. It is seen that vector \vec{i}_F is rotated around the origin from its original position of $0E$ to the subsequent position of $40E$, as ωt increased from $0E$ to $40E$. In fact, in the case of a balanced set of currents considered in the present illustration, the tip of vector \vec{i}_F describes a circle as ωt increases from zero to $360E$, as shown in Figure 2.10.

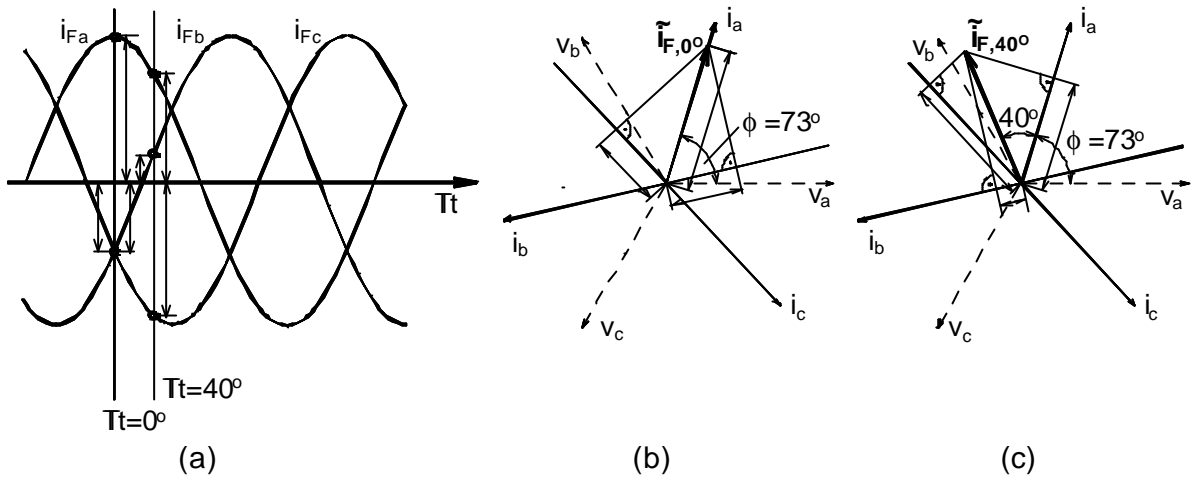

Figure 2.9 Vector representation of the instantaneous variables at $\omega t = 0E$ and at $\omega t = 40E$ (The furnace currents i_{Fa} , i_{Fb} , and i_{Fc} represent operating point 1 with $I_F = 1.35$ p.u.).

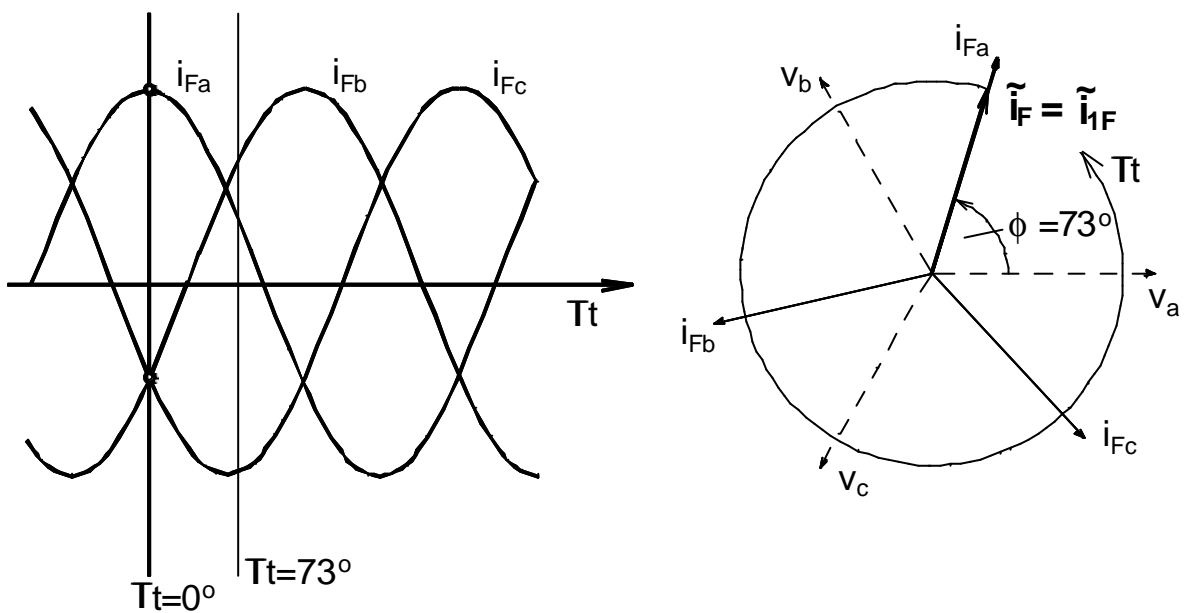

Figure 2.10 A set of balanced furnace currents (i_{Fa} , i_{Fb} , and i_{Fc}) represented by vector $\tilde{i}_F = \tilde{i}_{1F}$ (The furnace currents i_{Fa} , i_{Fb} , and i_{Fc} represent operating point 1 with $I_F = 1.35$ p.u.).

In general, as the values of the phase variables change, the tip of the associated vector describes various trajectories as it moves around the origin in the plane. Under unbalanced conditions, such as characterising the (linear) arc furnace load in operating point 2 (see Figures 2.5 and 2.6), vector \tilde{i}_F describes an ellipse, as illustrated in Figure 2.11.

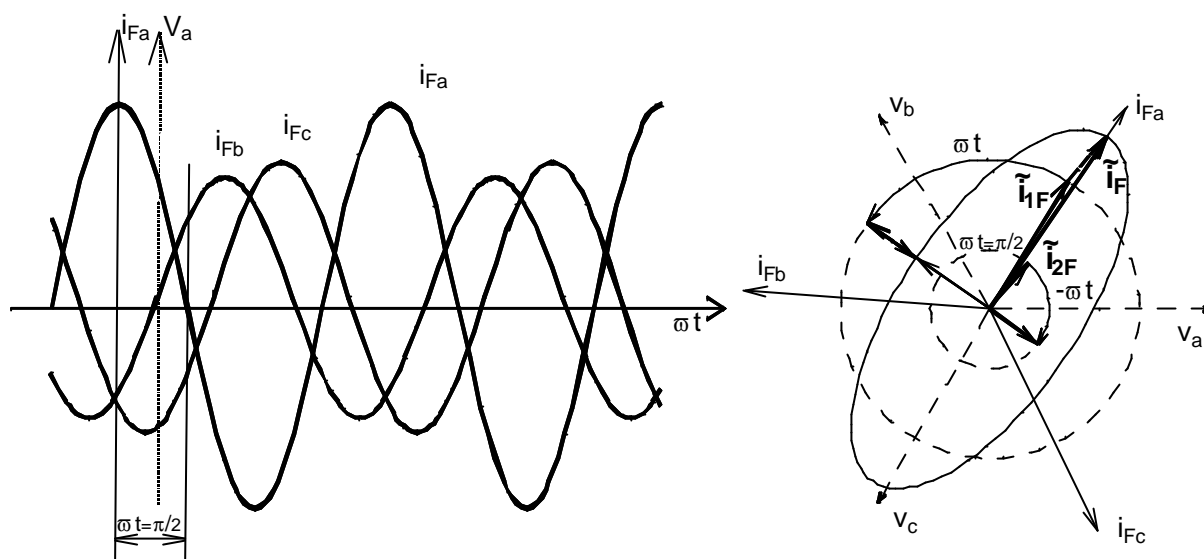

Figure 2.11 A set of unbalanced furnace currents (i_{Fa} , i_{Fb} , and i_{Fc}) represented by vector \tilde{i}_F which can be decomposed into positive sequence vector \tilde{i}_{1F} and negative sequence vector \tilde{i}_{2F} (The furnace currents i_{Fa} , i_{Fb} , and i_{Fc} represent operating point 2 with $I_{Fmax,bal} = 1.35$ p.u.).

In this case, the furnace current vector \tilde{i}_F could be considered to be composed of two constituent vectors; that is, $\tilde{i}_F = \tilde{i}_{1F} + \tilde{i}_{2F}$, where \tilde{i}_{1F} is the positive sequence vector rotating counter clockwise with ωt , and \tilde{i}_{2F} is the negative sequence vector rotating clockwise with ωt . Actually, a vector in a general case would contain all of the information the instantaneous variables in the three-phase set can provide: fundamental negative sequence component due to unbalance, harmonic and extrabasal components representing waveform distortion, as well as short duration transient components. Sometimes it is convenient to consider a general vector as a sum of a number of vectors, each representing a particular constituent of the total information. Two of the constituent vectors may represent, as in the above case, the positive and negative sequence fundamental components rotating in the opposite direction at the system angular frequency. Some others may represent different positive and negative sequence harmonic components, which rotate clockwise or counter clockwise at integral multiples of the system angular frequency. Still others may represent non-synchronous components rotating at non-integral sub or super multiples of the fundamental angular frequency. The amplitudes of transient components would decay with ωt .

For the purpose of controlling the output of the compensator, it is useful to view the corresponding voltage and current vectors in an orthogonal co-ordinate system with p and q axes such that the p axis is always coincident with the instantaneous voltage vector \tilde{v} and the q axis is in quadrature with it, as illustrated in Figure 2.12.

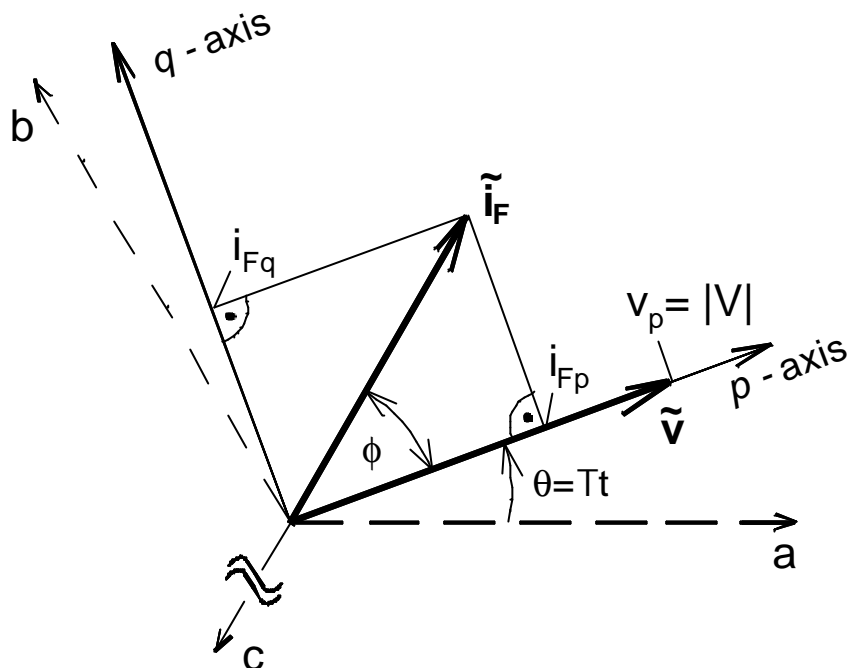

Figure 2.12 Illustration of the “Rotating Reference Frame” concept.

In this co-ordinate system the p -axis current component, i_p , accounts for the instantaneous real power and the q -axis current component, i_q , for the reactive power. The p and q axes are not stationary but rotate synchronously with the voltage vector in the plane. Under balanced steady-state conditions, the p -axis and q -axis components of the voltage and current vectors in the synchronously rotating reference frame are constant (magnitude) quantities, which characteristically considerably simplifies the implementation for the de-coupled control of the real and reactive current components. Of course, the non-synchronous components of the vector, e.g., harmonic and extrabasal components, if present, rotate at a different speed than the reference frame and they appear as a “ripple” on the constant fundamental quantities. These “ripple” components, depending on the control implementation, may have to be removed or altered by filtering in the control signal path in order to prevent their interference with the desired compensation. It is also possible to establish a number of reference frames rotating at different speeds to separate the dominant constituents of the vector for control purposes. For example, additional synchronous reference frames may be provided for large individual harmonic components to facilitate their attenuation by independent control loops.

2.4 COMPENSATION BY STATCOM [2-4]

Conceptually, and from the application viewpoint, the STATCOM (Static Synchronous Compensator) can be considered as an ideal three-phase generator. Internally, this generator functions as an almost perfect voltage source, producing three, individually controllable output

voltage waveforms in a relatively wide frequency band. Normally, the produced waveforms form a balanced sinusoidal set at the fundamental frequency. However, the output may be controlled to contain negative sequence components for prescribed unbalance and, within the operating frequency band, also harmonic and any other extrabasal and transient components to synthesise a desired waveshape. With a properly designed power electronic circuit (see Section 2.5), the response time of the STATCOM can be very small, a small fraction of period time of the fundamental component. Thus, such a STATCOM is able to reproduce a complex multi-component, rapidly varying vector that characterises the operation of the arc furnace.

The STATCOM, just like a rotating generator, is able to generate internally, without a.c. capacitors or reactors, capacitive or inductive reactive power necessary for arc furnace compensation. In addition, it can also exchange real power with the a.c. system, if this power is supported by an external source/sink or an appropriate energy storage. For arc furnace compensation, the STATCOM is usually equipped with an energy storage d.c. capacitor of suitable rating to average the real power demand of the furnace.

The symbolic representation of the STATCOM, as an “electronic generator”, together with a summary of its basic characteristics, is shown in Figure 2.13.

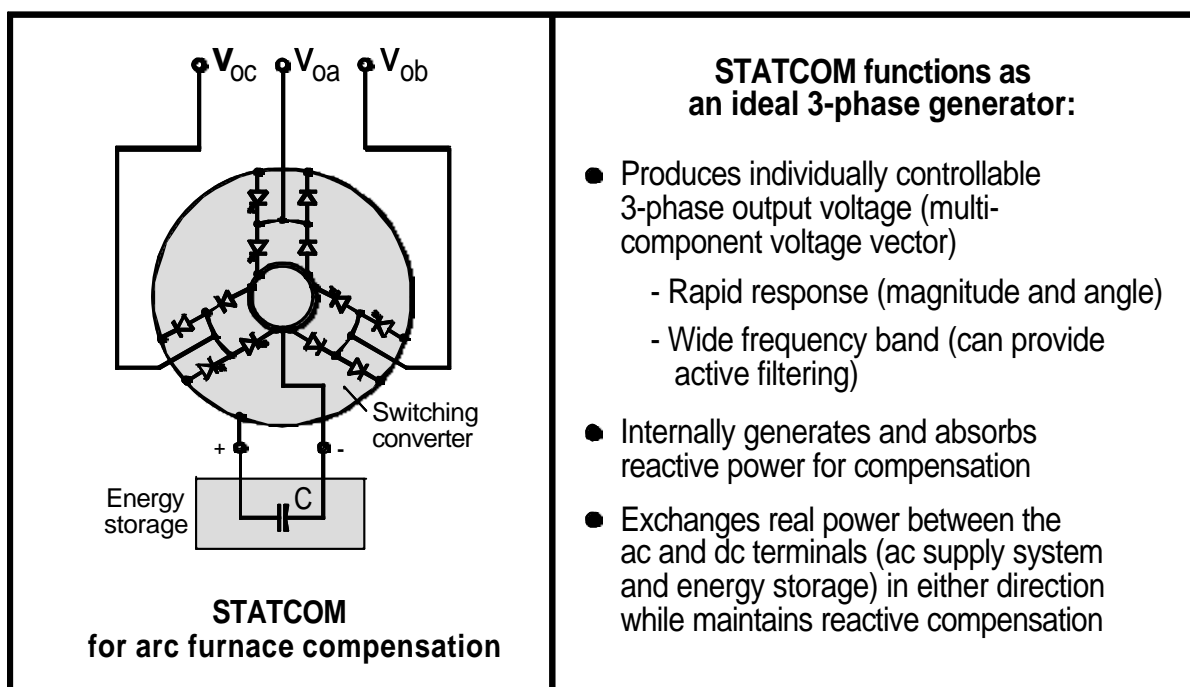

Figure 2.13 Characteristics of the STATCOM for arc furnace compensation.

A general arc furnace compensation scheme with a STATCOM is shown in Figure 2.14. As can be seen, the general concept is to control the STATCOM so that the line current vector \vec{i} , obtained as the sum of the furnace current vector \vec{i}_F and the STATCOM current vector \vec{i}_o , will not cause

flicker and meet other power quality requirements. In other words, the STATCOM is controlled so as to accomplish the compensation requirements stipulated earlier in terms of current fluctuation and flicker, load unbalance, power factor and distortion.

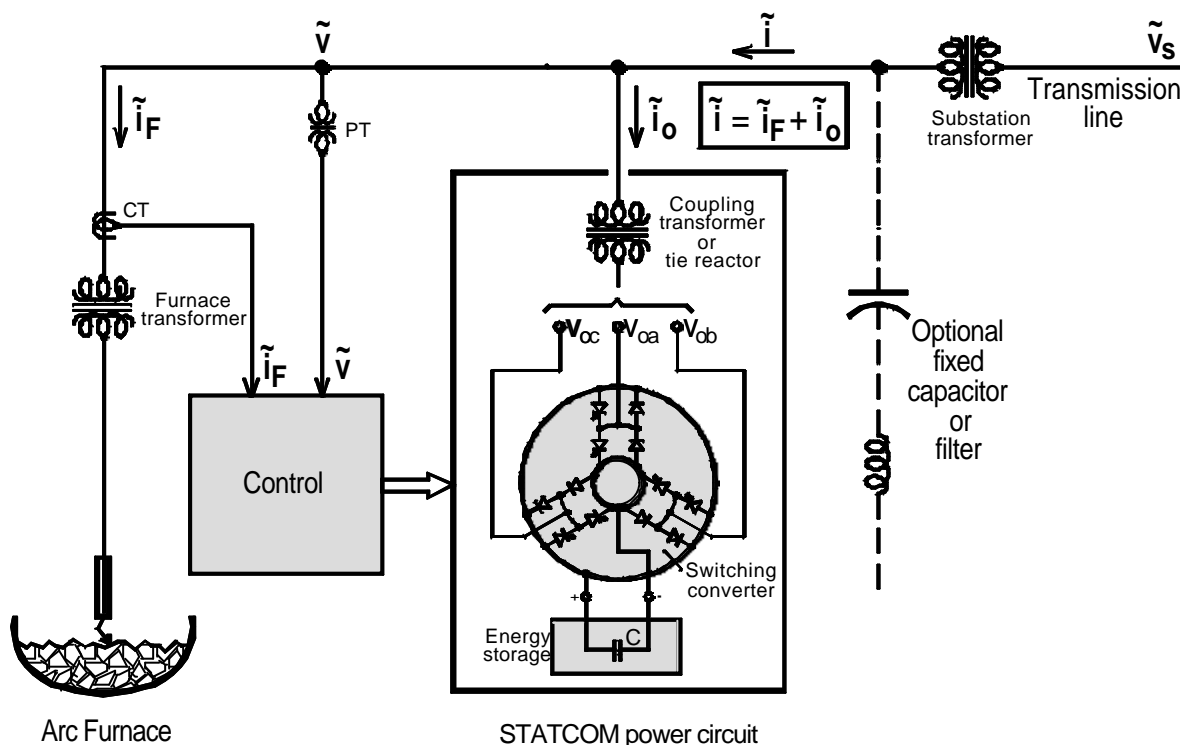

Figure 2.14 Arc furnace compensation by STATCOM.

In the general control scheme the instantaneous values of the arc furnace phase currents are measured and processed appropriately in co-ordination with the system voltages to derive the instantaneous values of the compensating phase currents that the STATCOM needs to draw to accomplish the desired compensation. The directly controlled variables are actually the three internal phase voltages of the STATCOM, represented by voltage vector \tilde{v}_o , which force the desired currents through the three tie inductances provided by either the leakage inductance of the coupling transformer or a separate set of three tie reactors.

The desired compensation can be accomplished by different control approaches. For example, the above mentioned possibility of separating the individual components of interest from each other (by providing a separate synchronously rotating reference frame for each of them) suggests that the positive and negative sequence fundamental quantities, as well as the significant non-fundamental components of interest could be compensated individually, using separate control loops. With this objective, control schemes could theoretically be devised which select specific unwanted components of the furnace current (e.g., fundamental reactive component, negative

sequence component, and dominant “distortion” components) and force the STATCOM to eliminate (or reduce) them by generating similar components with opposite polarity. While this method generally seems to have the potential for highly effective compensation, in the case of the electric arc furnace the rapid and erratic variation of the three arcs, resulting in highly distorted and rapidly changing furnace currents characterised by a practically continuous spectrum in the frequency band of interest, the decomposition of the furnace current vector may not be carried out fast enough to obtain the flicker (and harmonic) reduction desired. This problem may be sufficiently handled by removing those distortion components, which are unimportant from the standpoint of visual flicker, or which are not part of the intended compensation in a particular loop, by applying appropriate filtering techniques in the relevant signal paths of the control.

In a different and more direct approach, instead of attempting to compensate for the selected constituents of the decomposed arc furnace current vector, STATCOM is forced by control to act as a current source and supply the total arc furnace load demand by injecting into the line the demanded arc furnace current vector. This, of course, cannot be done without some restrictions due to the facts that the STATCOM cannot produce the real power the arc furnace consumes and it has defined maximum MVA and current ratings. Thus, the compulsory physical constraint imposed is that, except for losses, the average real power the STATCOM supplies to the arc furnace must be zero. (The time interval over which the real power can be averaged is, of course, a function of the capacity (Joule) of the available energy storage (capacitor) at the d.c. terminals of the STATCOM converter.) The MVA rating constraint may limit the maximum reactive compensating current and the attainable overall load power factor. The maximum current rating of the STATCOM would automatically limit the attainable peak compensating current to handle the non-fundamental components on the arc furnace current. (The peaks of harmonics and extrabasal components may, under certain conditions, coincide with the peak of the fundamental reactive current, which event can increase the peak value of the required compensating current significantly).

A general control scheme for arc furnace compensation is shown in Figure 2.15. As seen, the three furnace currents, i_{Fa} , i_{Fb} , and i_{Fc} , is converted into current vector \vec{i}_F , with in-phase and quadrature components, i_{Fp} , and i_{Fq} . (These components are given as scalar quantities since their angle is fixed with respect to reference co-ordinate frame.) The vector quantities are all in the fundamental reference frame derived from the supply voltage with an appropriate phase-locked loop. To the i_{Fp} component the error signal representing the difference between the d.c. voltage reference and the measured d.c. voltage is summed. This sum represents the instantaneous real power demand of the arc furnace and the STATCOM.

The three output currents of the STATCOM, i_{oa} , i_{ob} , and i_{oc} , are converted into current vector \vec{i}_o , with in-phase and quadrature components, i_{op} , and i_{oq} . These components are compared to the corresponding furnace current components, or their selected components thereof, and the difference signals, together with the prevalent line voltage magnitude, are used via appropriate loops to control the wanted internal voltage vector of the STATCOM, \vec{v}_o , (with in-phase and quadrature components v_{op} , and v_{oq}). Vector \vec{v}_o is converted to the (instantaneous values of the) three phase voltages the STATCOM power circuit (converter) is to produce to draw the desired compensating currents from the power system through the effective tie reactors.

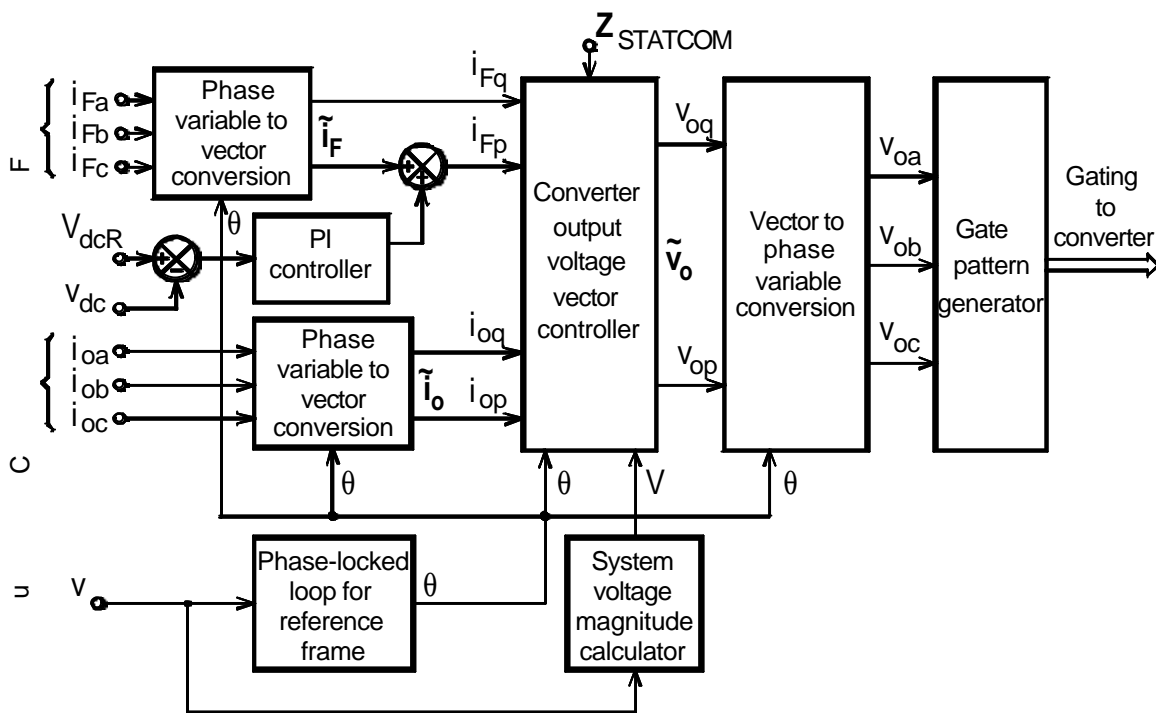

Figure 2.15 General control scheme of STATCOM for arc furnace compensation.

Note that the physical constraint requiring the average real power output of the STATCOM be zero is accomplished by the control loop changing the arc furnace real current (power) component so as to maintain the converter d.c. terminal voltage at the set reference. The averaging time constant is determined by the energy storage capability i.e., by the size of the d.c. capacitor.

The capability of the STATCOM to supply the “instantaneous” reactive power, and averaging the “instantaneous” real power demand of the arc furnace is demonstrated by the results of real time, TNA (Transient Network Analyser) type simulations shown in Figures 2.16 and 2.17, respectively. The top part of these figures show the plots of three arc furnace currents together with the corresponding supply voltages at the primary side of the arc furnace transformer. These currents and voltages were recorded at an actual installation and subsequently used to simulate faithfully the arc furnace operation in the TNA set up.

The bottom part of Figure 2.16 shows the instantaneous reactive power (corresponding to the current and voltage waves at the top) the arc furnace absorbs (gray line) together with that the STATCOM supplies (black line). The capability of the STATCOM to provide during unbalance the largely second harmonic fluctuating power component, as well as to follow the erratic statistical variations of the furnace reactive power due arc instability is well observable in the figure.

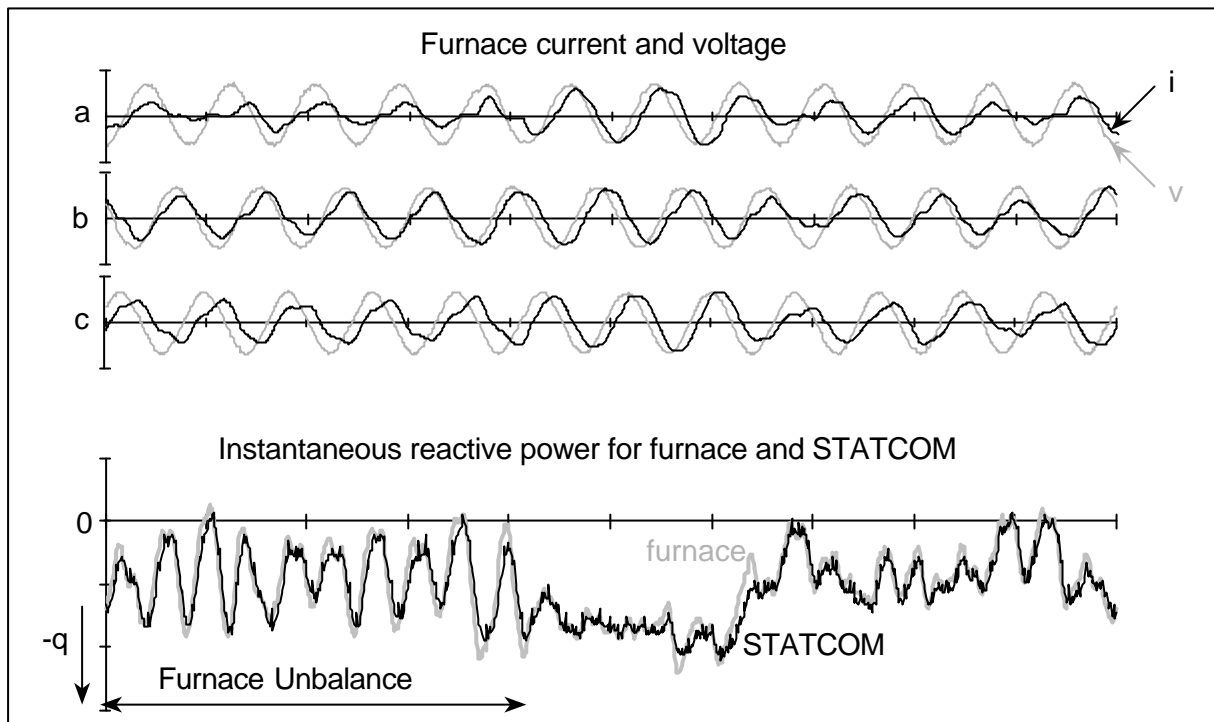

Figure 2.16 Compensation of the furnace instantaneous reactive power by STATCOM.

The bottom part of Figure 2.17 shows first the actual “instantaneous” real power (corresponding to the same current and voltage waves shown also in the previous figure) the arc furnace consumes (gray line), second the real power exchange of the STATCOM with a.c. system (lower black line), and finally the resultant “instantaneous” real power the a.c. line supplies to the combined furnace and STATCOM load (upper black line). It can be observed that the STATCOM averages the furnace real power fluctuation and the a.c. supply system “sees” an almost constant slow varying real load. (Recall that the real power averaging is accomplished via the controlled power exchange facilitated by the STATCOM between the a.c. system and the d.c. energy storage capacitor.)

The reader should recognise that the general control scheme illustrated, and the possible approaches mentioned, provide only basic frameworks for the compensation. The detailed implementation of the actual control, together with the switching capability of the converter power circuit, will determine the attainable bandwidth of the overall compensator and thereby the possible flicker and harmonic attenuation. There are presently only a few converter-based compensator installations of different designs. Although the details of the control designs for these installations are not revealed, it is likely that they represent different approaches, certainly different circuit and software implementations. Still, as the measured flicker reductions, as will be shown later, seem to indicate that their overall performance is overall comparable. This shows that, as expected, comparable end results can be achieved by different designs applying similar considerations and using compatible technological tools.

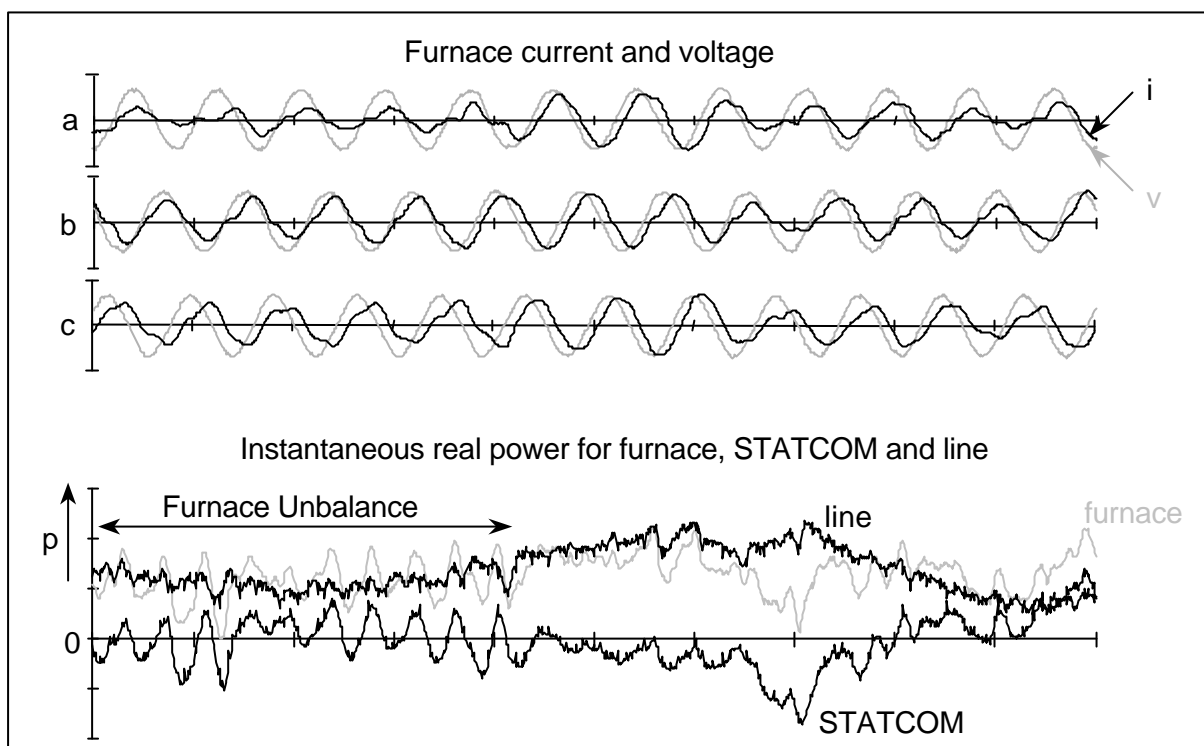

Figure 2.17 Averaging the furnace instantaneous active power by STATCOM.

2.5 BASIC STATCOM POWER CIRCUIT APPROACHES [2-5]

The functional capability of ideal generator required for the STATCOM in arc furnace applications can be realized by various power converter circuits. For a high power converter, used as the STATCOM power circuit for arc furnace compensation, the key issue that determines the power circuit structure is the method used to synthesize the output voltage waveform with rapidly (almost instantaneously) controllable magnitude and phase. The waveform synthesis should be able to closely approximate a single sine-wave at the fundamental frequency (in order to eliminate or minimize the need for harmonic filtering), or ensemble of sine waves to approximate an arbitrary waveform in the frequency band of interest. In arc furnace (and other utility) applications the converter used is the d.c. to a.c. “voltage-sourced” type. This means that the converter synthesizes the set of three output voltages from a d.c. source voltage. This type of converter can internally generate reactive power for the load and is able to exchange real power between the a.c. terminal load and the d.c. source. From the control standpoint, the voltage-sourced converter could be considered as a wide-band controllable three-phase amplifier that, when supported by the d.c. source, can supply both real and reactive power for the load. As already established, in arc furnace application the d.c. source is replaced by a d.c. energy storage capacitor (or other suitable device) for the purpose of averaging fluctuating real power by supplying the peak energy demands of the furnace and recover these energy “lumps” from the a.c. supply system when the energy demand of the furnace is low.

The discussion in this section is based on Section 2.3 (Practical STATCOM Power Circuit Structures) of CIGRE Technical Brochure 144 [2-5], where the subject of voltage source converters for power system compensation are treated in considerable detail.

The power circuit structure of the converter may be of different complexity depending on the number of d.c. voltage levels that can be produced at the a.c. output of a multi-level converter pole. The pole, composed of two or more valves, usually comprising a number of semiconductors in series connection, is the basic building block of the converter.

A “two-level” pole, Shown in Figure 2.18, is the simplest switching arrangement capable of producing a.c. output from a d.c. source in the form of a simple square-wave. This waveform, without pulse width modulation (PWM), has large harmonic content and it is unable to facilitate direct control of the amplitude of its fundamental output voltage.

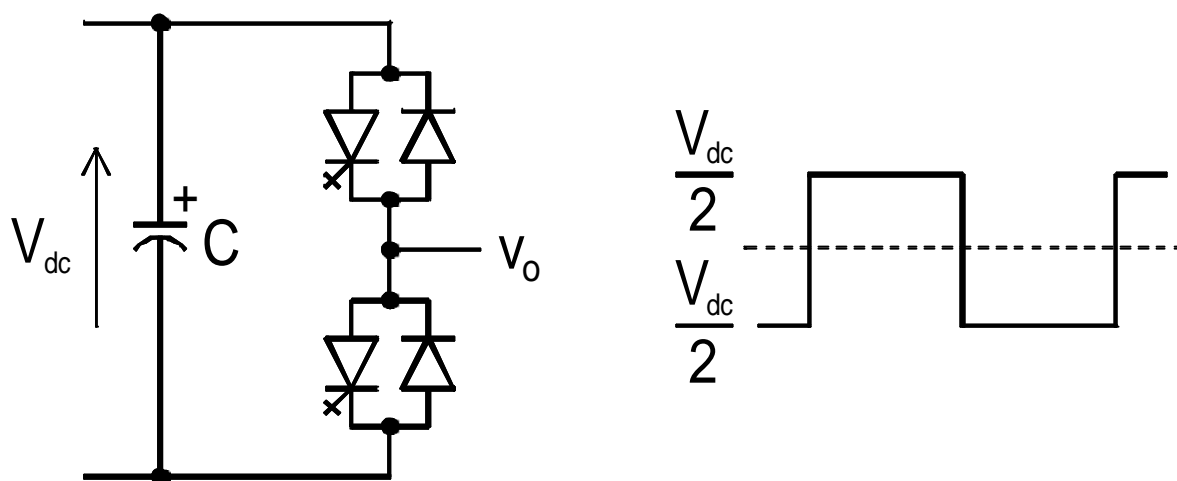

Figure 2.18 Basic two- level pole and associated output voltage waveform.

The “three-level”, “diode clamp” pole, shown in Figure 2.19, has three input terminals to connect to a split or center-tapped d.c. source, that is, the output voltage of the three-level pole can be positive, negative, or zero. The simultaneous gating of the upper two valves connects the output to the $+V_{dc}$, and the gating of the lower two valves connects it to the $-V_{dc}$, with respect to the mid-point of the d.c. capacitors. The simultaneous gating of the two inner valves connects the output via the two “clamp diodes” to the midpoint, representing zero output voltage. The three-level pole can be used effectively for the control of the amplitude of the fundamental voltage, or the elimination of selected harmonic components from the output, by the appropriate adjustment of angle α , controlling the zero interval of the output voltage, as illustrated Figures 2.19 (a), (b) and (c). However, the operating advantages of the three-level pole can only be fully realized with some increase in circuit and control complexity, as well as with the accommodation of the increased a.c. ripple current with a generally high triple-n harmonic content flowing through the mid-point of the d.c. supply.

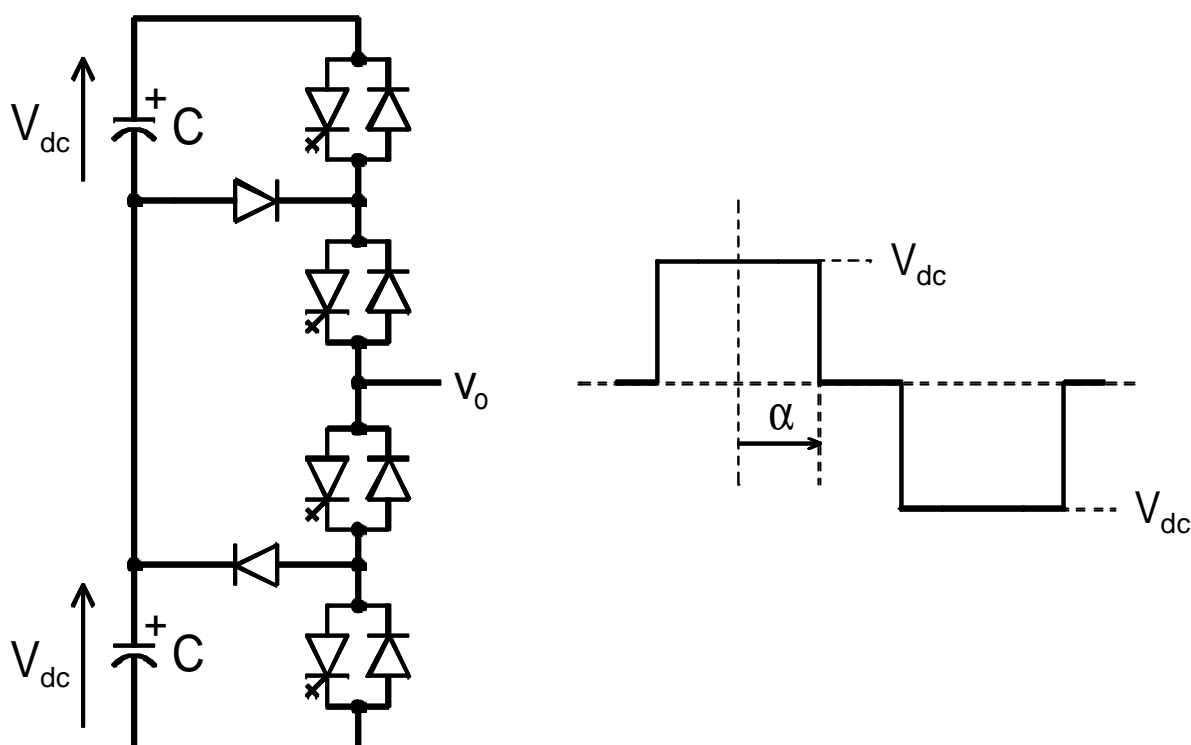

Figure 2.19 Basic three-level, diode clamp pole and associated output voltage waveform.

It should be noted that, instead of the clamp diodes, the three-level pole can be implemented with a bi-directional valve (e.g., one composed of a string of reverse parallel connected GTOs) connecting the output direct to the mid-point. In this case, the two upper and two lower valves could be integrated into a single valve of $2V_{dc}$ voltage rating. The mid-point valve voltage rating is V_{dc} . With this arrangement the upper valve connects the output to the positive d.c. voltage, the lower valve to the negative d.c. voltage, and the mid-point valve to zero voltage. The mid-point valve may provide improved controllability for current commutations, at the likely expense of higher hardware cost.

Another possible alternative to the three-level pole is the “flying capacitor” approach, illustrated in Figure 2.20. In this arrangement, an additional capacitor, connecting the mid-point of the upper two valves to that of the lower two valves, facilitates the generation of zero voltage output. Similarly to the clamping diode scheme, the simultaneous gating of the upper two valves connects the output to the $+V_{dc}$, and the gating of the lower two valves connects it to the $+V_{dc}$, with respect to the mid-point of the two main d.c. capacitors. However, in order to produce zero output voltage, either the shaded or the unshaded upper and lower valves needs to be gated on. This action connects the “flying capacitor” in series with either the upper main capacitor (shaded valves) or with the lower main capacitor (unshaded valves) with an opposite polarity voltage. The

V_{dc} voltage of the flying capacitor thus cancels the V_{dc} voltage of the main capacitor, resulting in zero output voltage.

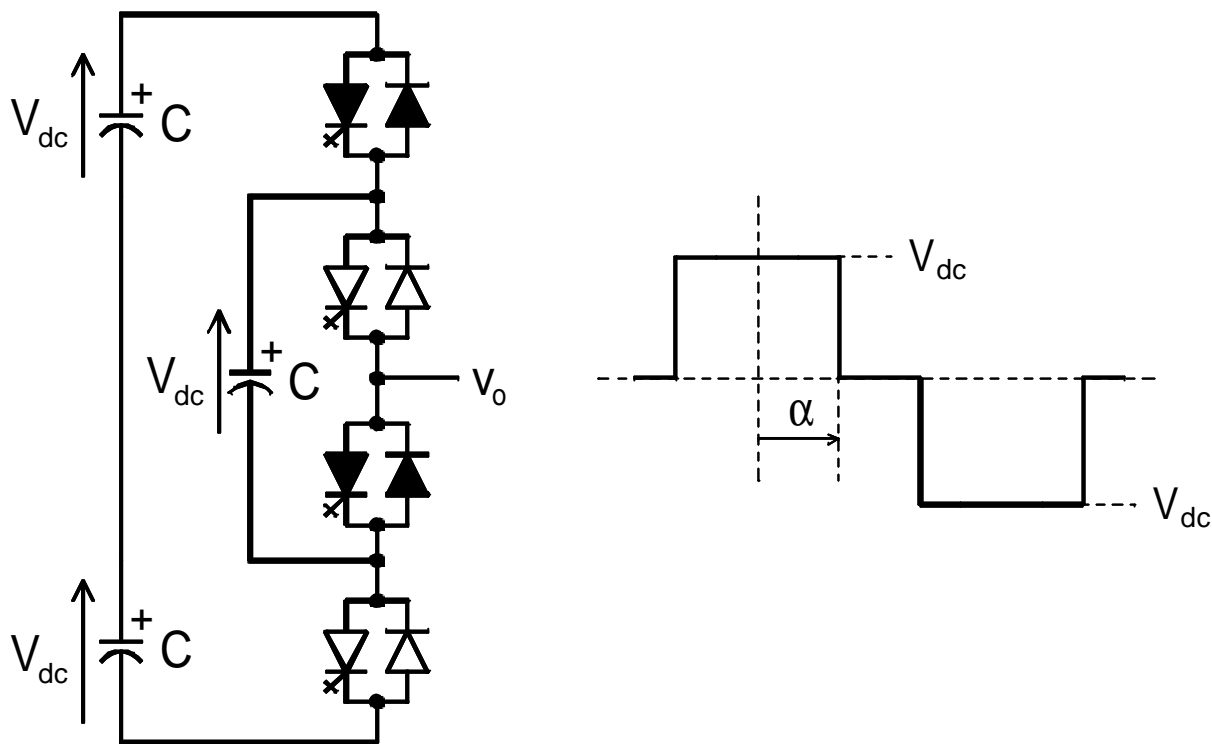

Figure 2.20 Basic three-level, flying capacitor pole and associated output voltage waveform.

It should be noted that in a three-phase arrangement, each pole must have its own flying capacitor and only the main capacitors can be common for the three poles.

The disadvantage of the three-level “flying capacitor” scheme is the large increase in the rating of the required d.c. capacitors. It is not only that three “flying capacitors” are needed in addition to the two main capacitors, but also that the “flying capacitors” must be rated for large current ripple comprising all $2n$ ($n=1,2,3,\dots$) frequencies, even if the load is fully balanced in which case the ripple current in the main capacitors would comprise only the $6n$ components. This latter rating requirement is not a significant penalty in arc furnace applications, where the load is often unbalanced and all capacitors must be rated accordingly.

Basic converter schemes using two-level and three-level poles for arc furnace compensation are shown in Figures 2.21 and 2.22.

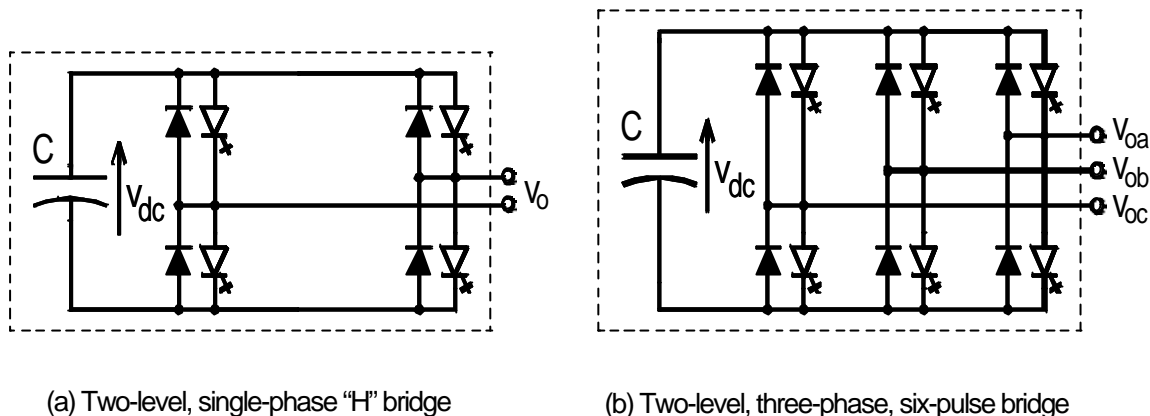

Figure 2.21 Basic two-level constituent circuit schemes for arc furnace compensating STATCOMs.

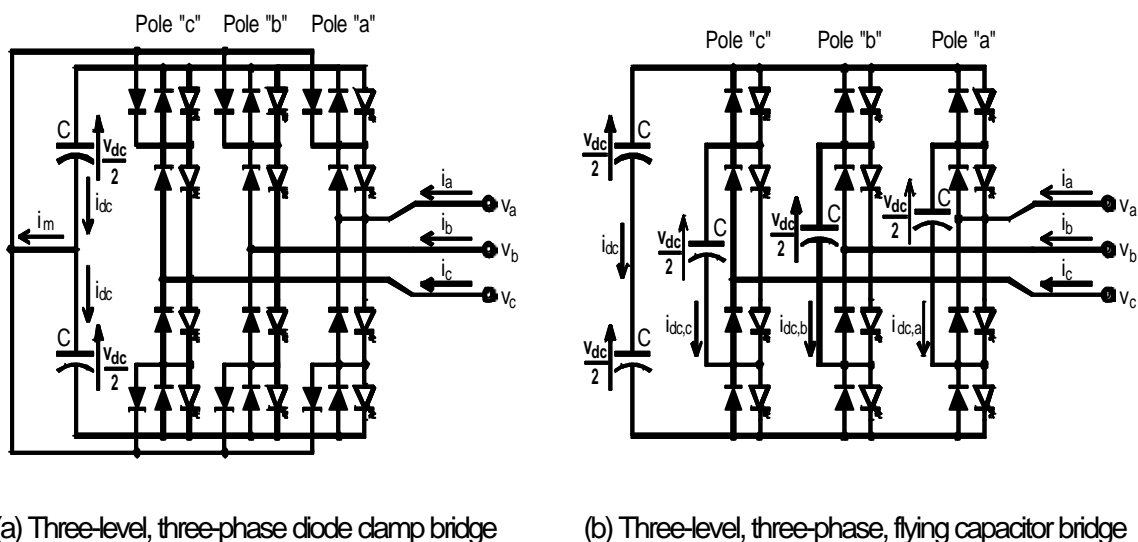

Figure 2.22 Basic three-level constituent circuit schemes for arc furnace compensating STATCOMs.

The harmonic content of the a.c. output voltage could be further reduced by extending the three-level pole to a general $2n+1$ "multi-level" pole structure with $2n$ ($n=1,2,3,\dots$) series connected storage capacitors and $4n$ valves. Basic circuit arrangements for five-level output using the clamp diode and flying capacitor schemes are shown in Figures 2.23 and 2.24, respectively. Inspection

of these figures clearly suggests that both the circuit complexity, control and operational difficulties rapidly increase with the number of voltage levels in both schemes.

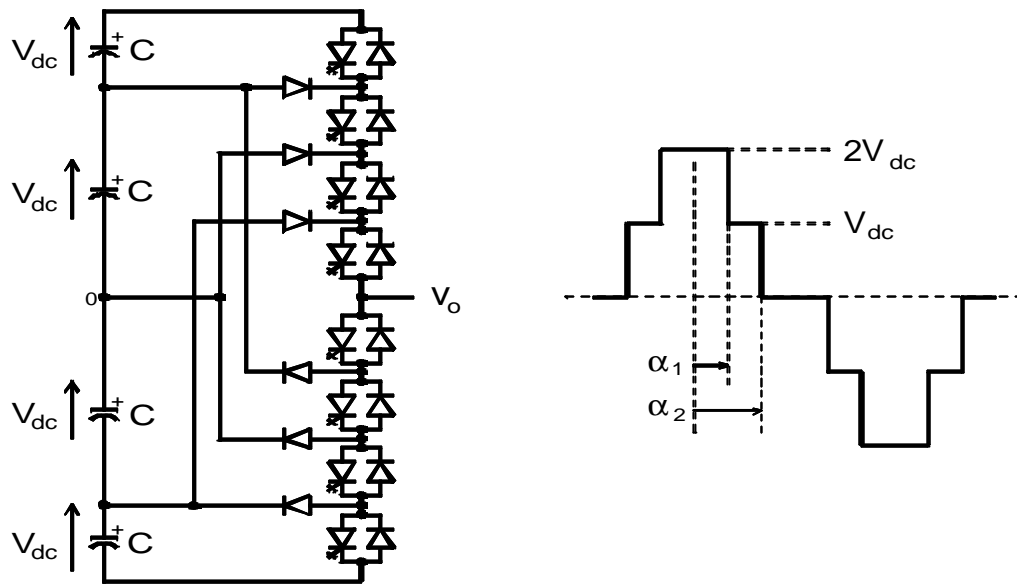

Figure 2.23 Five-level, diode clamp pole and associated output voltage waveform.

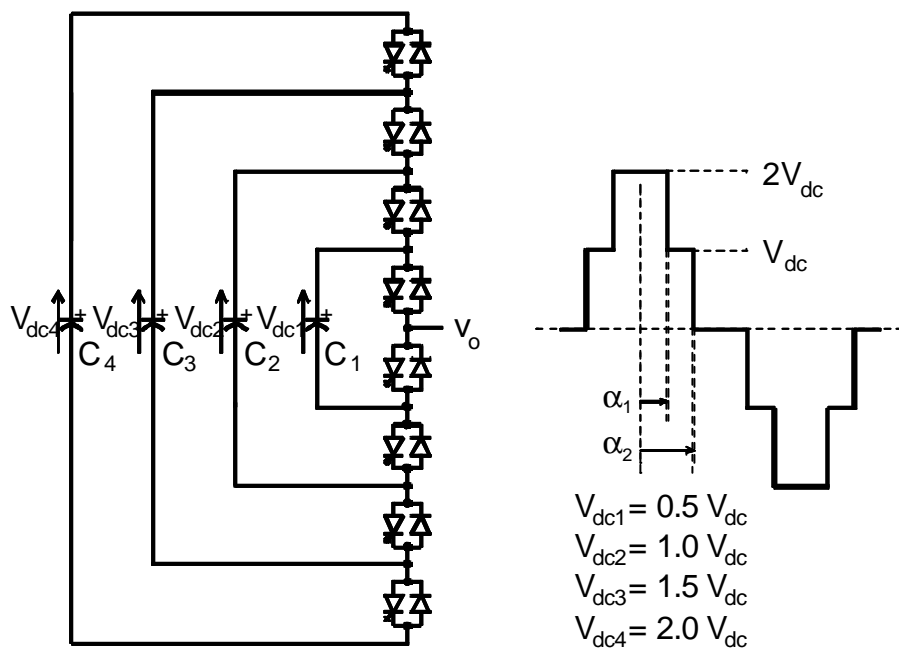

Figure. 2. 24 - Five-level, flying capacitor pole and associated output voltage waveform.

In the multi-level clamp diode scheme the uneven utilization of the valves and the escalating voltage ratings of the clamp diodes raise the question of economical viability, in addition to the considerable technical difficulties of managing the current transfers in different commutation loops and maintaining the proper voltage balance on the capacitor chain.

Similarly, the number and VA rating of the required flying capacitors (which are repeated in each pole) and the unequal utilization of the valves tend to make the flying capacitor scheme, both from the standpoints of cost and physical size, increasingly unattractive with increasing voltage levels. Also, the maintenance of the proper voltage on each capacitor and the execution of the different switch combinations to get the desired voltage level through the appropriate series connection of a number of flying capacitors can pose considerable control and operational challenge in a high power converter.

A different multi-level approach is to connect single-phase bridge circuits in series, as illustrated in Figure 2.25a. In the thus obtained “chain” circuit, as seen, each pole consists of a number of single-phase voltage-sourced bridge converters, connected in series on their a.c. side to form a chain. There is a separate, isolated d.c. capacitor associated with each link. A three-phase circuit can be made by a wye (Y) or delta (Δ) connection of three such chains.

Each of the GTO diode pairs operates as two-way switches. At any instant a switch can connect its associated capacitor with “positive” or “negative” polarity into the chain, or bypass it, and therefore each link can contribute a voltage of $+V$, $0V$ (capacitor bypassed) or $-V$. With n links connected in the series the circuit synthesizes a voltage waveform with $(2n + 1)$, voltage levels, which with sufficient links can give a good approximation to a sine-wave, as illustrated for a five-level chain circuit in Figure 2.25b.

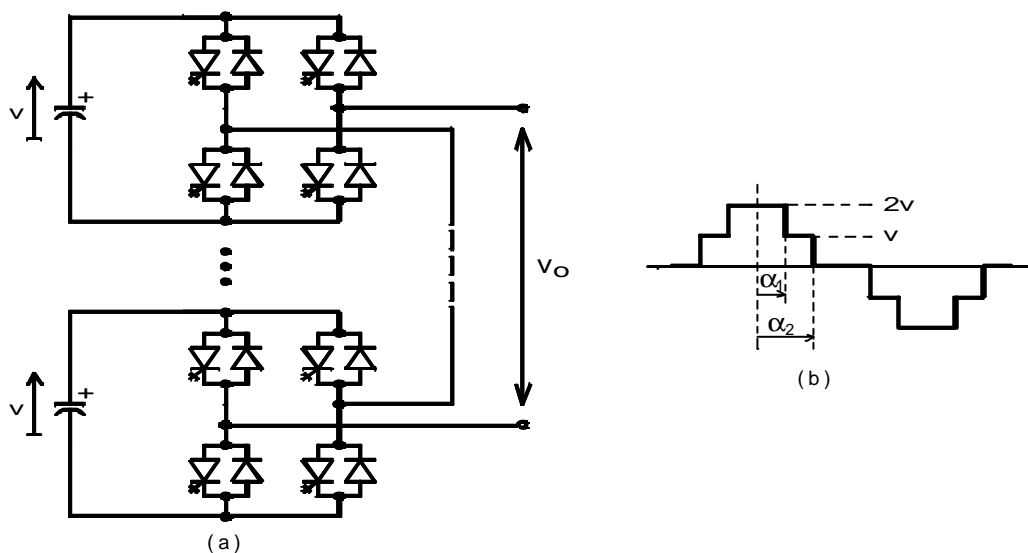

Figure. 2. 25 Multi-level “chain” circuit (a), and five-level output voltage waveforms obtainable with two links (b).

The chain circuit represents a straightforward approach for realizing a multi-level converter, which can be used for high power applications, without the need for magnetic combining circuits and/or complex transformers. Also it provides a well defined operating environment for the power semi-conductors, within a substantially isolated single phase bridge circuit. The single-phase converter structure can readily provide single-phase compensation, as required for arc furnace compensation.

The PWM technique, illustrated in Figure 2.26 for an elementary two-level pole, is well established and commonly used by relatively low power converters to generate high quality output waveforms. This technique is applicable to two, three and multi-level poles in practically any converter structure. With PWM control, the output of each converter pole is switched several times during a fundamental cycle between the relevant positive and negative terminals of the d.c. source and the time intervals between consecutive switchings are controlled so that the average of the positive and negative volt-second segments of the output waveform generated follows the wanted sine-wave.

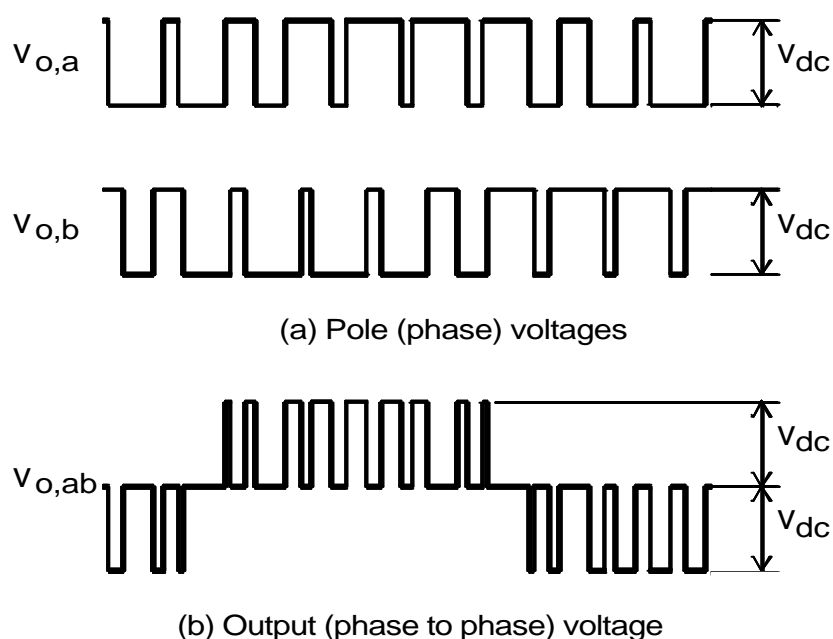

Figure 2. 26 Typical pulse-width-modulated pole (phase) and output (phase to phase) voltage waveforms.

The application of PWM, particularly with high frequency switching, in high power converters lagged other techniques of output waveform synthesis, primarily because of the switching limitations, and the resultant losses, of the then-available large power semiconductors. Major efforts expended in the development of improved semiconductors resulted in new devices, such as the Integrated Gate Commutated Thyristor (IGCT) and the Insulated Gate Bipolar Transistor (IGBT), which allow the practical realisation of high power PWM converters with circuit structural and operational benefits and, depending on the application requirements, acceptable operating losses.

Pulse-width modulation technique, offering fast response and wide frequency band of operation, is well suited for the generation and control of the output voltage of the STATCOM converter used for arc furnace compensation.

An output voltage waveform that approximates an ideal sine-wave as closely as desired, without any increase in switching frequency, can be synthesized by “harmonic neutralization” techniques, using multi-pulse converter structures. This technique also offers fast response and wide operational frequency band, with low operating losses at the expense of increased circuit complexity.

The basic principle of harmonic neutralization is to combine the inputs and outputs of a number of basic six-pulse converters, which are operated with an appropriate phase-displacement, so as to cancel all harmonics except those which correspond to the pulse number of the multi-converter structure. The combination of the a.c. output voltages of the individual converters is usually accomplished by phase-shifting transformers or an equivalent magnetic structure. A classical harmonic neutralization circuit structure using two two-level elementary converters for a 12-pulse output voltage waveform, and two three-level converters for a 24-pulse waveform, are shown in Figure 2.27 and 2.28.

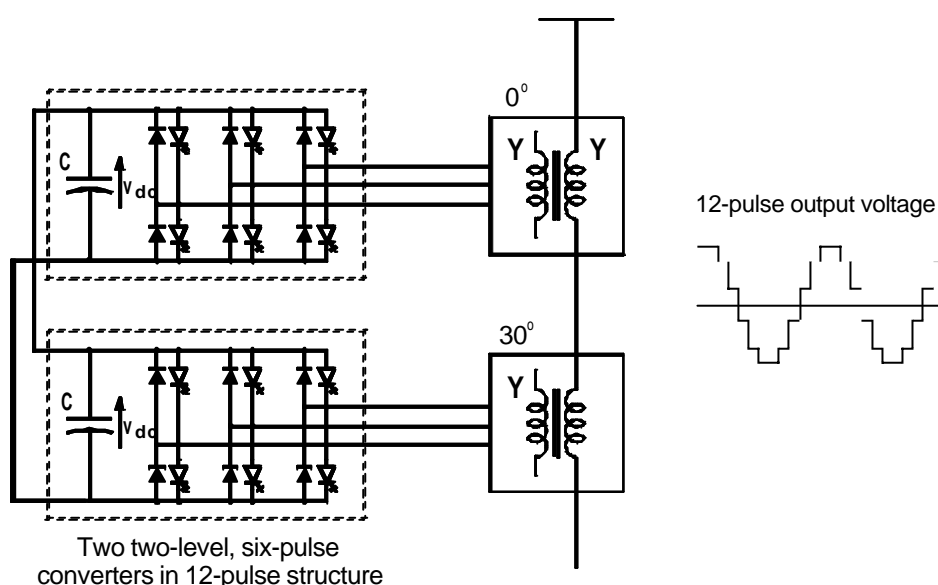

Figure 2.27 - Two-level, 12-pulse converter scheme.

All of the basic approaches (multi-level, PWM, and multi-pulse) for the generation of output voltage waveform with low distortion have some shortcomings in terms of complexity, losses, or cost and, for these reasons, these techniques may be applied in some appropriate combination, particularly for high power STATCOMs, to provide an optimal circuit configuration and operating mode for a given application. It should be pointed out here too that, to date, only two-level poles and three-level poles with clamping diodes have been employed with harmonic

neutralisation and/or pulse-width-modulation in practical high power STATCOMs used for arc furnace compensation.

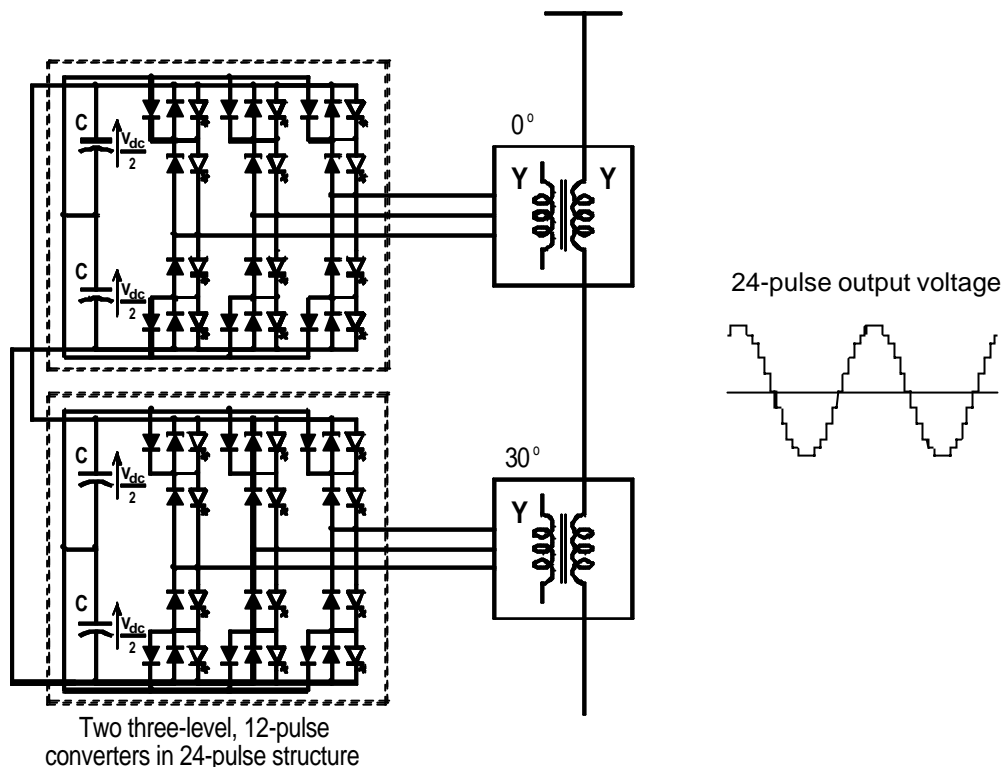

Figure 2.28 - Three-level, 24-pulse converter scheme.

2.6 FLICKER REDUCTION ACHIEVED BY STATCOM IN ACTUAL INSTALLATIONS

The flicker reduction achieved in actual STATCOM installations are briefly described in this section with detailed information on individual installations being provided in Chapter 6.

The flicker reduction achieved by a STATCOM in the case of an arc furnace of 70MW (80MVA) nominal rating at Seguin, USA is shown in Figures 2.29 and 2.30 [2-6]. In this case, the STATCOM rating is nearly the same as the arc furnace rating. The figures clearly illustrate that with the STATCOM in operation a flicker reduction factor of at least 4 times is easily achieved for this particular installation. In this case based upon the long established experience of the utility and the customer the performance of the STATCOM and the arc furnace installation was evaluated using the so-called “Schwabe Flicker Meter” extensively utilised in the USA. The flicker measurements were carried out at the 138 kV flicker bus, and the flicker level recorded and shown in Figures 2.29 and 2.30 was the voltage variation in percent (according to the measurement definition given for the Schwabe meter) with respect to the r.m.s. bus voltage. A brief description of the “Schwabe Flicker Meter” is given in Appendix C.

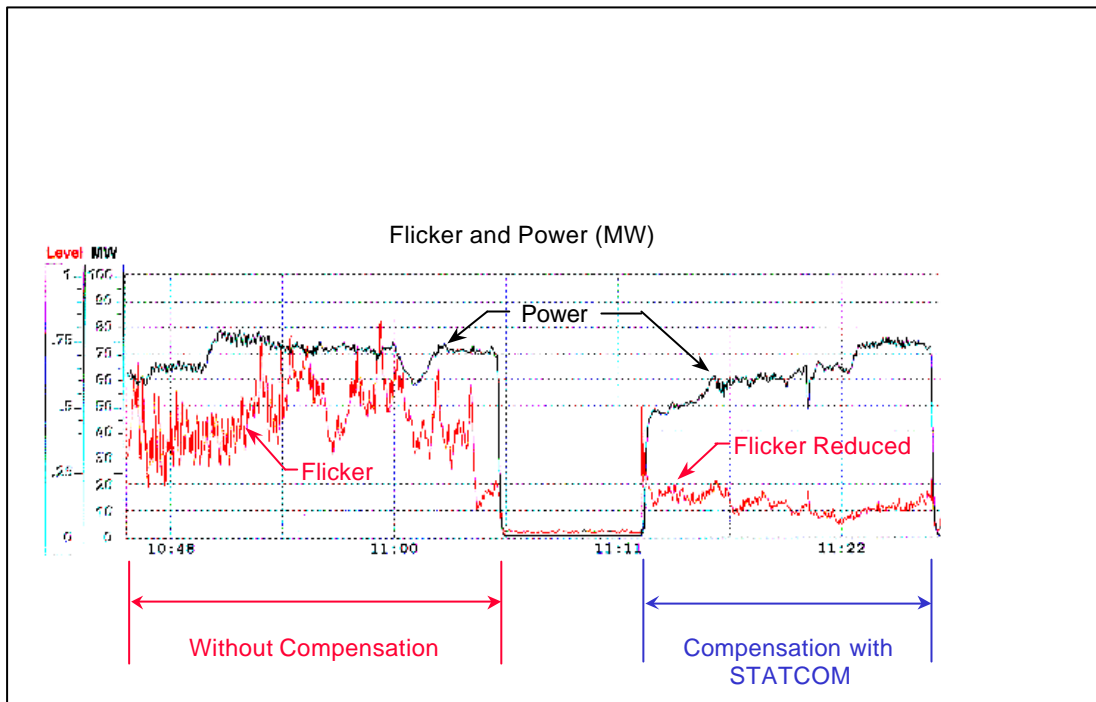

Figure 2.29 Flicker measured at a 70MW (80MVA) arc furnace installation at Seguin, USA without and with STATCOM compensation.

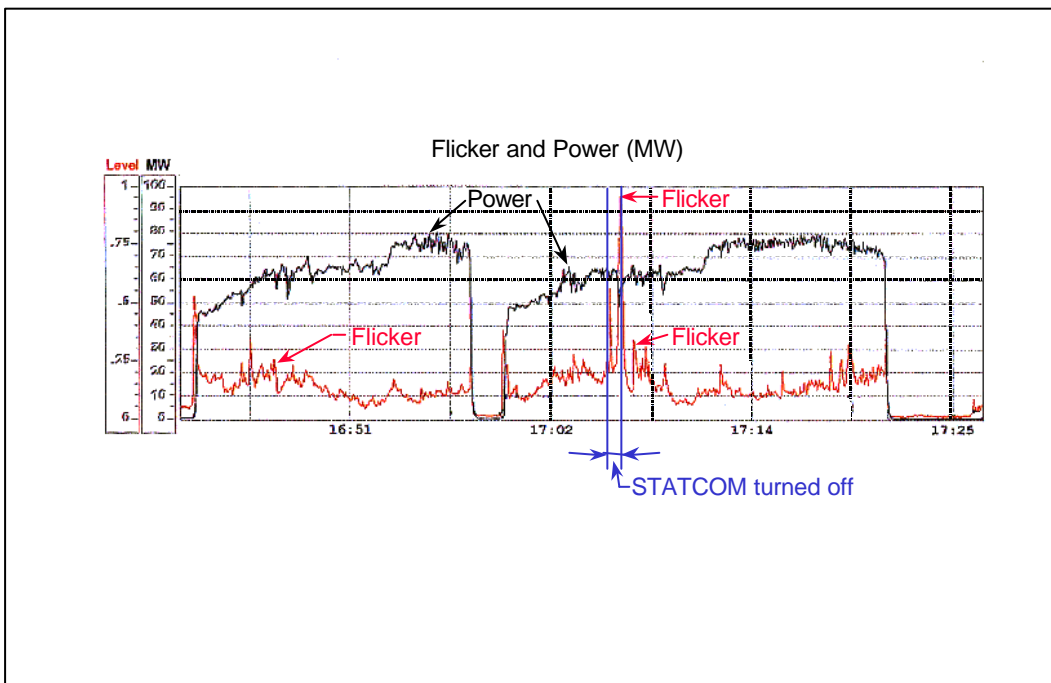

Figure 2.30 Flicker reduction at a 70MW (80MVA) arc furnace installation at Seguin, USA by STATCOM compensation.

In a similar manner, the flicker reduction achieved by STATCOM applications, in the case of an arc furnace of 38MW rating at Hagfors, Sweden and of 25MW rating at Trier, Germany are respectively shown in Figures 2.31 and 2.32. Again, the figures clearly illustrate that it is possible to achieve a flicker reduction factor of at least 4 times and better with STATCOM compensation of approximately the same rating as the arc furnace rating.

In Figure 2.31 the measurement was initiated during the weekend (14 April 2000) when the electrical arc furnace was out of operation. Around noon on 16th of April, an electrical arc furnace electrically remote from the actual steel plant where the measurements were being conducted started. In the evening of the 16 April 2000, the arc furnace at the steel plant where the measurements were being conducted started. Initially the STATCOM was not in operation. In the morning of the 17 April, the STATCOM was put into operation. The flicker reduction observed from these measurements was $P_{st95\%} = 3.75$ without the STATCOM reducing to $P_{st95\%} = 0.76$ with the STATCOM. The measurements indicated that a flicker reduction of around five times was achieved by the compensator.

Figure 2.33 shows typical measured harmonic currents from an electrical arc furnace. In this figure, the horizontal axis represents the harmonic order and the vertical axis represents the individual harmonic current as a percentage value of the fundamental frequency arc furnace current. The STATCOM due to its rapid response acting as an active filter to reduce the harmonic components of the arc furnace current is evident from this figure.

As described in the Section 2.1, the large and erratic swings of the real and reactive arc furnace current components, together with the harmonic and other extrabasal current components, cause corresponding voltage variations across the impedance of the a.c. supply network. This results in fluctuating terminal voltage with appreciable distortion and unbalance. The terminal voltage unbalance means that high values of the negative sequence components would be present furnace in the arc furnace current. Thus, reduction in the negative sequence currents indicates an improvement in furnace performance. Figure 2.34 shows the histogram of measured arc furnace current unbalance, expressed as the negative sequence component in relation to the average positive sequence current. The reduction in the arc furnace negative sequence current components and hence the terminal voltage fluctuations due to the operation of STATCOM is clearly evident from this figure.

References [2-4, 2-6, 2-7, 2-8] describe the design principles, installations and the measurements while reference [2-9] refers to the performance evaluation of arc furnace compensation which will be discussed in Chapter 4. Further detailed information on the rating, configuration and performance of the arc furnace installations with STATCOM compensation is given in Chapter 5. The reader's attention is drawn that in the case of one manufacturer the registered trademark "SVC Light" is used to describe STATCOM compensation installations in the literature.

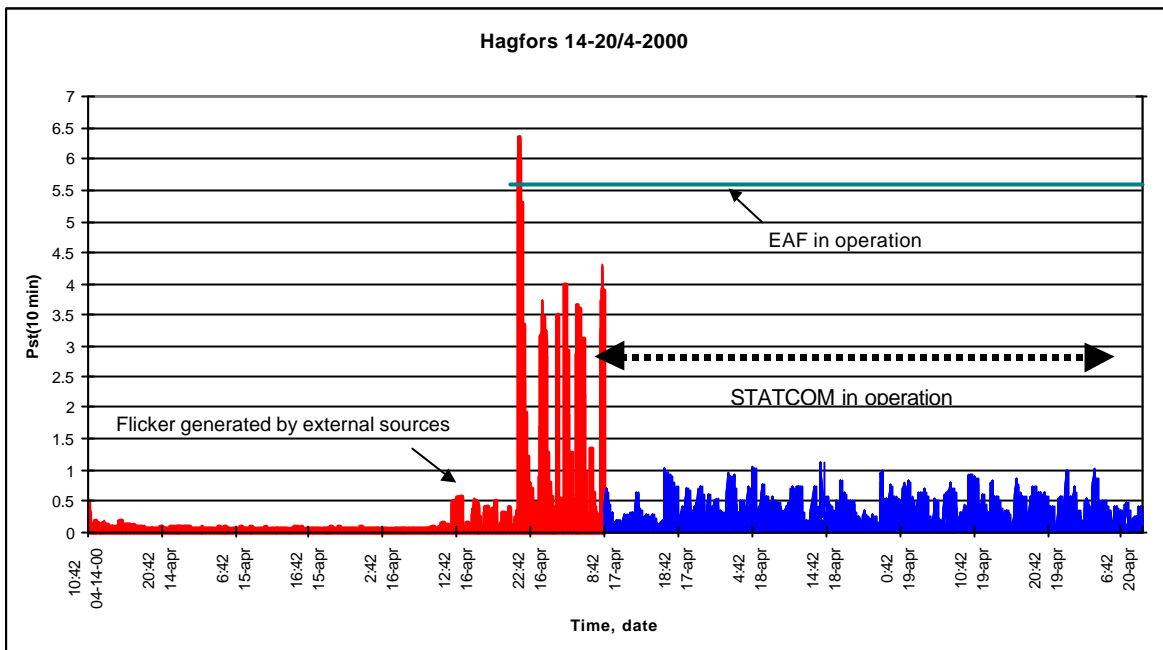

Figure 2.31 Flicker reduction at a 38MW arc furnace and 7MW ladle furnace installation at Hagfors, Sweden by STATCOM compensation.

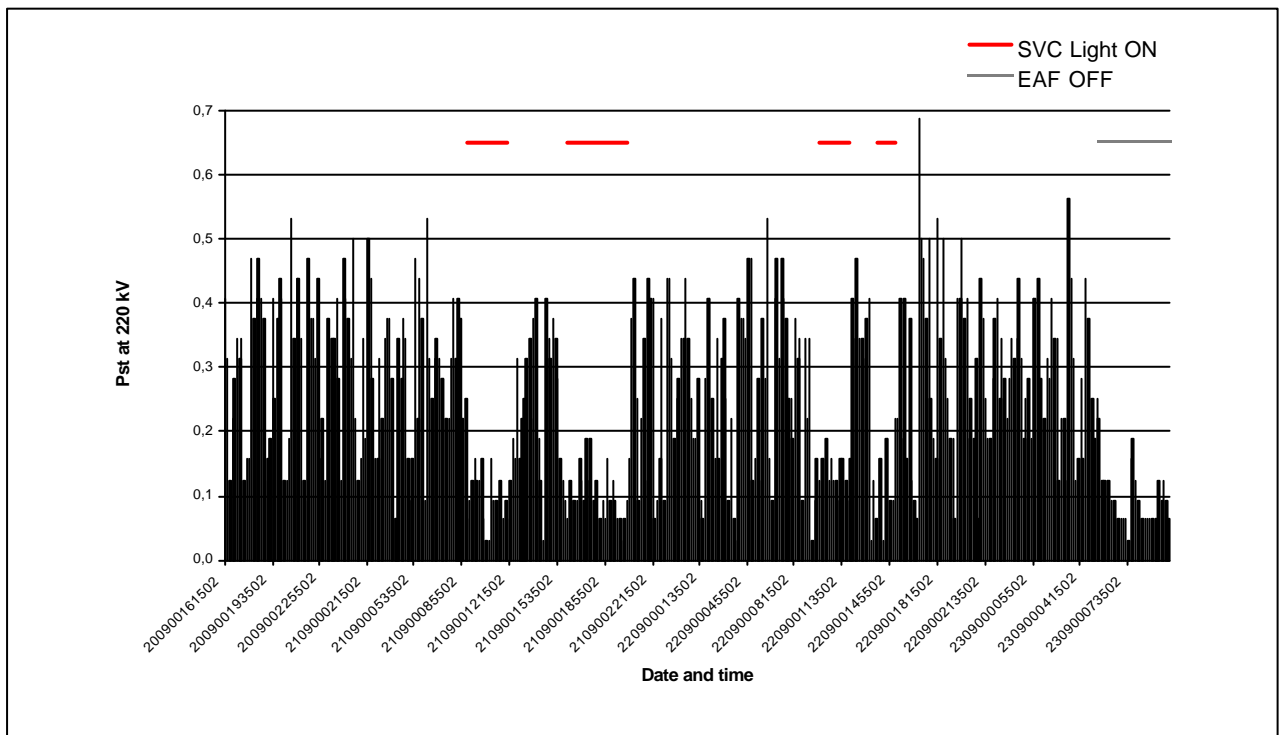

Figure 2.32 Flicker reduction at a 25MW arc furnace installation at Trier, Germany by STATCOM compensation.

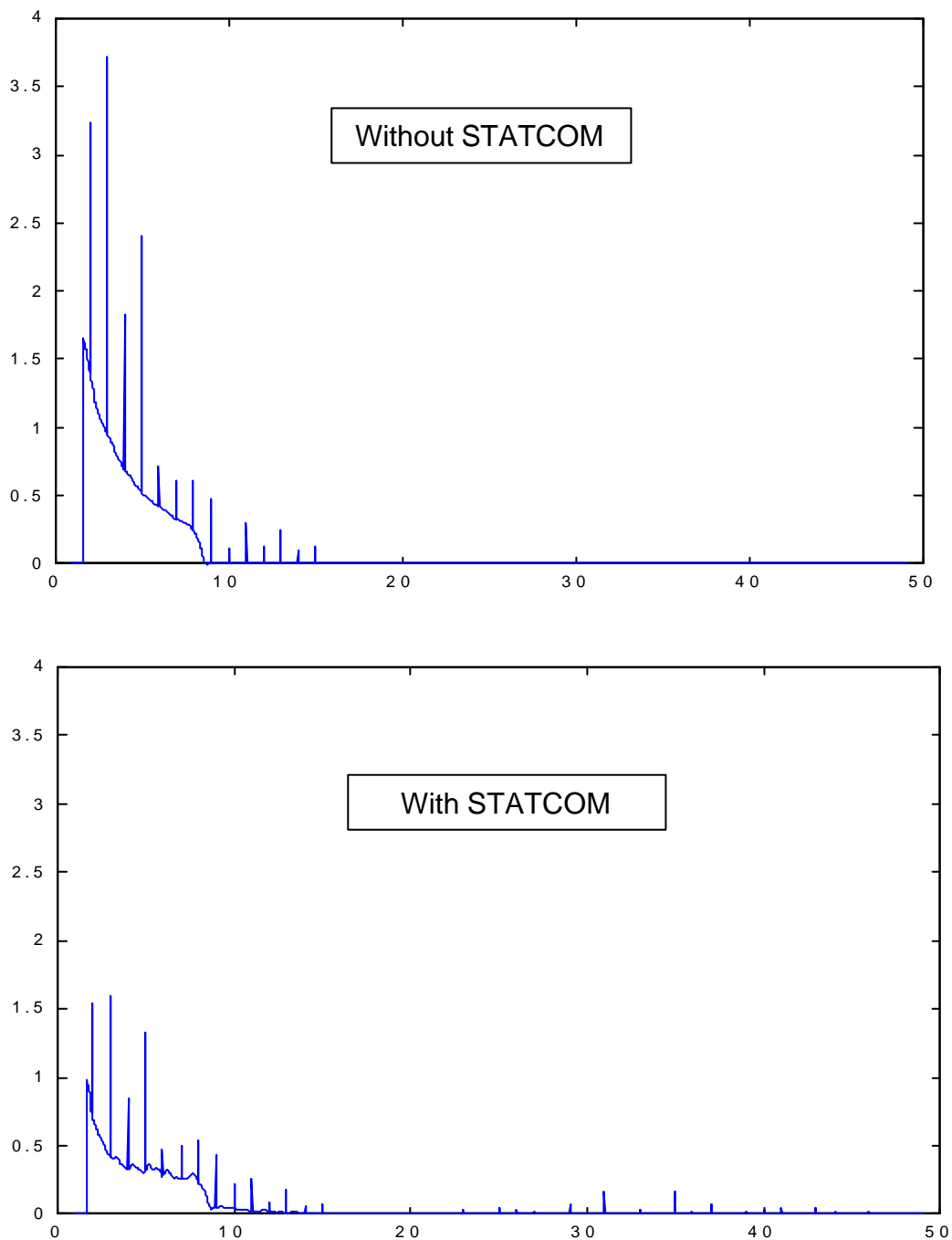

Figure 2.33: Harmonic current generated by an electric arc furnace EAF. (Vertical axis: Harmonic current from the furnace feeding into the power system expressed as a percentage of the fundamental, Horizontal axis: Harmonic order).

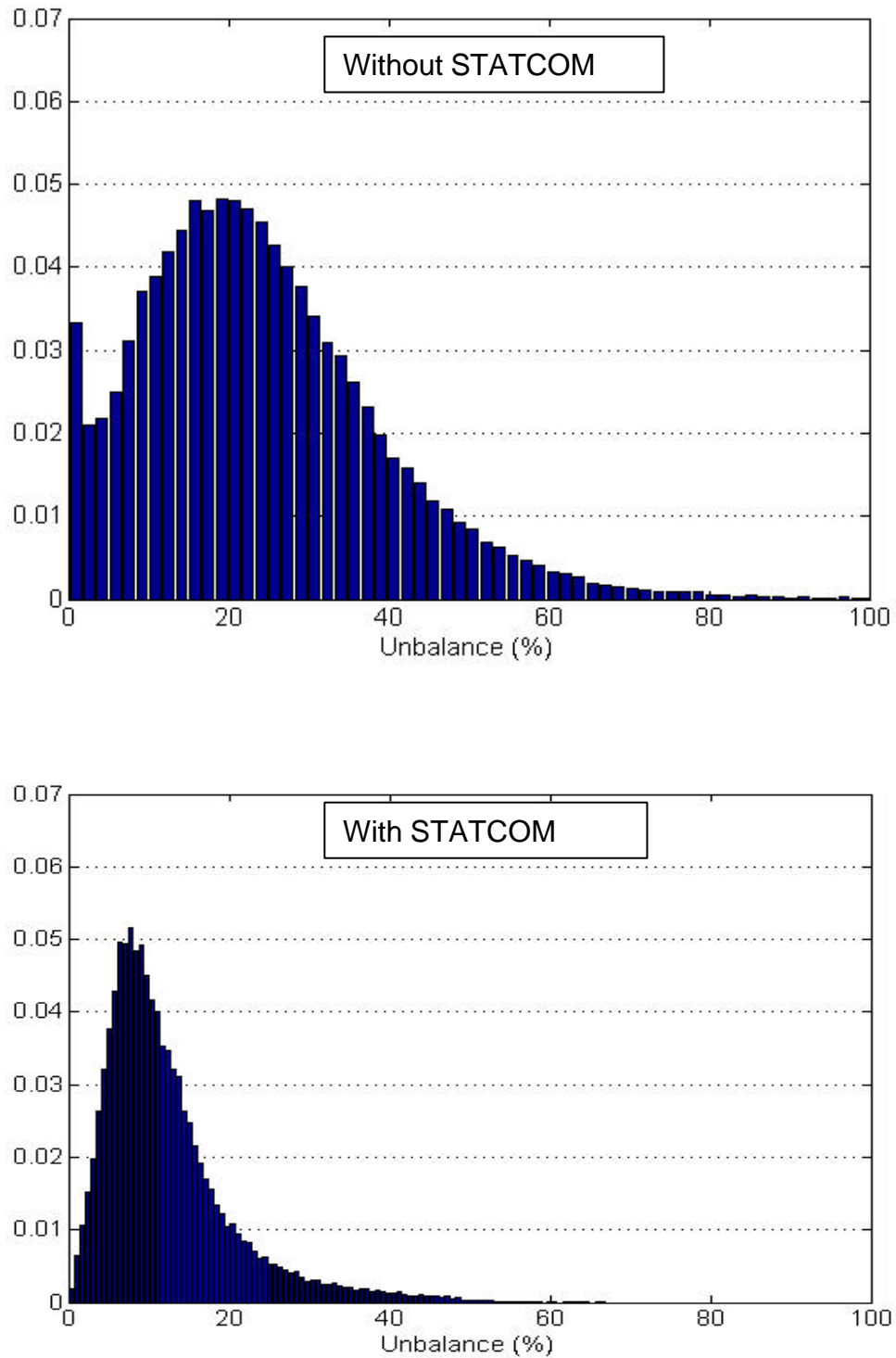

Figure 2.34 Histogram of the arc furnace current unbalance expressed by the ratio of the negative sequence current to the average positive sequence current in percent.

2.7 ACKNOWLEDGEMENTS

The author would like to acknowledge the contributions of Dr. Colin Schauder formerly of Westinghouse/Siemens, who was the lead designer of the STATCOM at Seguin, USA, and who produced the measured performance information on this installation included in this chapter. The author and the editor would also like to acknowledge the contributions of Mr. Tomas Gustafsson of ABB, who provided the performance information for this Chapter on the arc furnace installations compensated by the SVC Light.

2.8 REFERENCES

- [2-1] Gyugyi, L. and Otto, R.A. "Static Var Compensation of Electric Arc Furnaces", Union Internationale D'Electrothermie, VIII Congress, Section Va, Ref. No. 12, , Liege, 1975.
- [2-2] Gyugyi, L., Otto, R.A., and Putman, T.H. "Principles and Applications of Static, Thyristor-Controlled Shunt Compensators", IEEE Transactions on Power Apparatus and Systems, Vol. PAS-97, No. 5, Sept/Oct 1978.
- [2-3] Schauder, C.D, and Mehta, H. "Vector Analysis and Control of Advanced Static Var Compensators", IEE Fifth International Conference on AC and DC Transmission, Conference Publication No.345, pp 266-272, 1991.
- [2-5] Erinmez, I.A. and Foss, A.M. "Static Synchronous Compensator (STATCOM)" Report prepared by CIGRE Working Group 14.19, published by CIGRE as "Technical Brochure No 144" in August 1999.
- [2-4] Schauder, C.D. and Gyugyi, L. "STATCOM for Electric Arc Furnace Compensation", EPRI Workshop on Providing Quality Power to Steel Producers, Chicago, July 14-15, 1995.
- [2-6] Schauder, C.D. "STATCOM for Compensation of Large Electric Arc Furnace Installations", IEEE Power Engineering Society, Summer Meeting 1999, Volume 2, pp1109-1112.
- [2-7] Grünbaum, R., Gustafsson, T. and Johansson, T.: "SVC Light: a powerful flicker mitigator", Iron and Steel Society, 57th Electric Arc Furnace Conference, Nov14-16, 1999, Pittsburgh, PA, USA.
- [2-8] Hager, M., Gustafsson, T., Ingemars, B. Lahtinen, M., Olsson, U. and Agneholm, E. "Measurements Close to a 31.5MVA A.C. Arc Furnace with and without SVC Light", CIGRE Conference paper 36-202, CIGRE, August 2002, Paris.
- [2-9] Lahtinen, M. "New Method for Flicker Performance Evaluation of Arc Furnace Compensator", CIGRE Conference paper 36-205, CIGRE, August 2002, Paris.

Chapter 3 STATCOM CONTROL APPROACHES

Prepared by Guillaume de Preville, Michael Weinhold, Ani Gole and Dan Kell

3.1 INTRODUCTION

The previous two Chapters focused on the causes, consequences and measurement of flicker. The International Standards and recommendations for ensuring sufficient voltage quality throughout the system were described. Although well-proven equipment for mitigation of flicker such as SVC already exists, the capabilities and characteristics of STATCOM offer the utilities and industry additional benefits both in existing and new applications where application of the SVC by itself will not be able to deliver the required flicker mitigation performance.

This Chapter first examines the compensation control requirements for arc furnace flicker mitigation in relation to the basic circuit approaches of STATCOM and compares these approaches with the control strategies of STATCOM for main transmission system applications. The Chapter then provides detailed examples of control schemes for arc furnace flicker mitigation.

3.2 REQUIREMENTS FOR ARC FURNACE FLICKER MITIGATION

An arc furnace draws active as well as reactive power as shown in Figure 4.5 in Chapter 4 by the measurements from an actual arc furnace. The fluctuation of these power quantities is quite high and depends on the type and operational state of the furnace. The phase currents cause voltage drops across the system impedance, which may result in a flicker problem. In order to derive the compensation requirements the effect of the different current portions of the arc furnace current on the fluctuation of the PCC (Point of Common Coupling) voltage V_{PCC} must be analysed. Figure 3.1 shows a typical arc furnace arrangement and Figure 3.2 a simplified circuit diagram for analysis purposes.

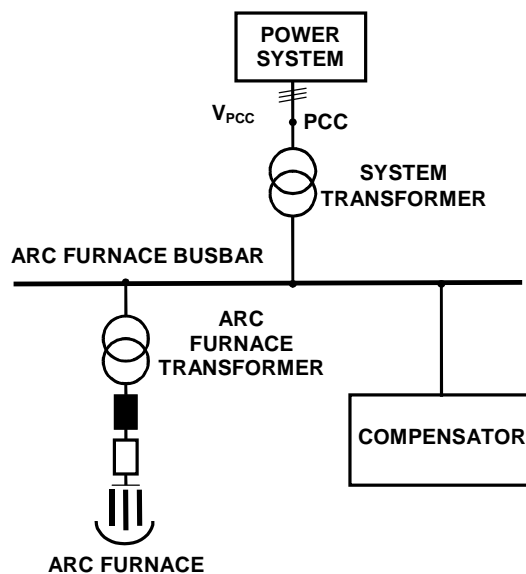

Figure 3.1: Example for connection of arc furnace plant with compensation to the power system.

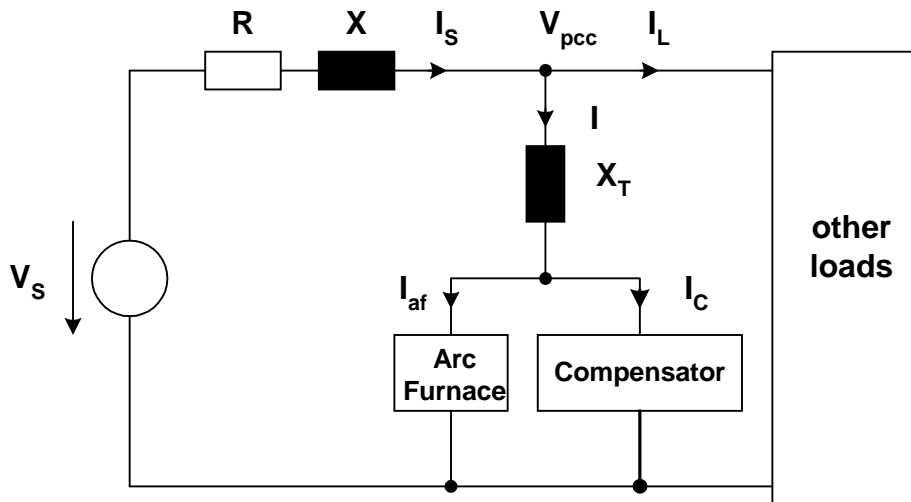

Figure 3.2: Simplified circuit for investigation of arc furnace compensation control strategies. The system impedance is modelled by the resistance R and reactance X . The impedance of the arc furnace plant transformer is modelled by the reactance X_T .

An analysis presented in reference [3-1] for example, shows that not only the fluctuations in reactive power but also in the active power, cause voltage deviations leading to flicker in the PCC voltage. The reactance of the transformer between the PCC and the arc furnace busbar is connected must also be considered for a complete analysis.

The Section of the Appendix B entitled “ i_d, i_q compensation theory” presents a complete analysis, of the various control strategies to mitigate the voltage fluctuation at the arc furnace busbar.

In principle there are two basic control approaches for mitigating the voltage fluctuation at the PCC:

- One basic control approach is to compensate the reactive power of the arc furnace and to smooth the fluctuations in active power consumption. This requires energy storage capability in the compensator. Such control schemes are presented in references [3-2], and [3-3]. As a consequence of applying this approach in full the arc furnace and the compensator appears as a purely ohmic load, which changes its resistance only very slowly. However, in order to achieve this the compensator must be able to instantaneously provide energy when the power consumption of the arc furnace changes. In contrast to dynamically responsive compensators, in arc furnace applications where passive compensation devices such as reactors and capacitors are connected, after calculations based on the well-known system equations, the control principle of the compensator in this case being described as “*compensation first, then adjustment*”. This means that the compensator in the short term, tries to maintain constant P and Q , and only refines its calculation slowly to adjust its output in order to accommodate power balance between the network and the arc furnace.
- The alternative control approach is to let the compensator inject only reactive power such that the voltage fluctuations at the PCC are eliminated [3-4]. Also the voltage fluctuation at the PCC resulting from changing active power consumption of the arc

furnace is cancelled by reactive current injection of the compensator. The advantage of such a control scheme is that the compensator does not require large energy storage equipment, which may result in smaller overall investment cost.

In general, the arc furnace current will cause both amplitude and phase fluctuations of the PCC-voltage. Since the flicker-meters have a very low sensitivity to phase fluctuations, it is sufficient for the compensator to cancel only the amplitude fluctuations.

In reference [3-1] it is shown that these amplitude fluctuations of the voltage at the PCC can be compensated by injecting a purely reactive current which corresponds to the second control approach. Here the voltage deviations due to active power fluctuation are taken care of by over-compensation of the reactive current. The details of such a control scheme for STATCOM are presented in Section 2 of Appendix B.

3.3 DIFFERENCES FROM TRANSMISSION STATCOM CONTROL

Chapter 4 of the CIGRE STATCOM Working Group document reference [3-5] gives an overview of STATCOM controller functions as shown in Figure 3.3. As outlined in the document the focus of the transmission system (power system) STATCOM is one or more of the following applications:

- Voltage regulation and control in systems with low short-circuit fault MVA levels;
- Improvement of steady-state power transfer capacity;
- Improvement of transient stability margin;
- Damping of power system oscillations;
- Damping of synchronous power system oscillations;
- Balanced loading of individual phases; and
- Reactive compensation of a.c./d.c. converters.

In contrast the task of a STATCOM for flicker mitigation is the elimination of certain portions of an arc furnace current which would cause unwanted voltage fluctuations at the PCC causing flicker. The transmission STATCOM exchanges mainly fundamental reactive current in quasi-periodic time dependency whereas the STATCOM for flicker mitigation mainly injects non-periodic currents.

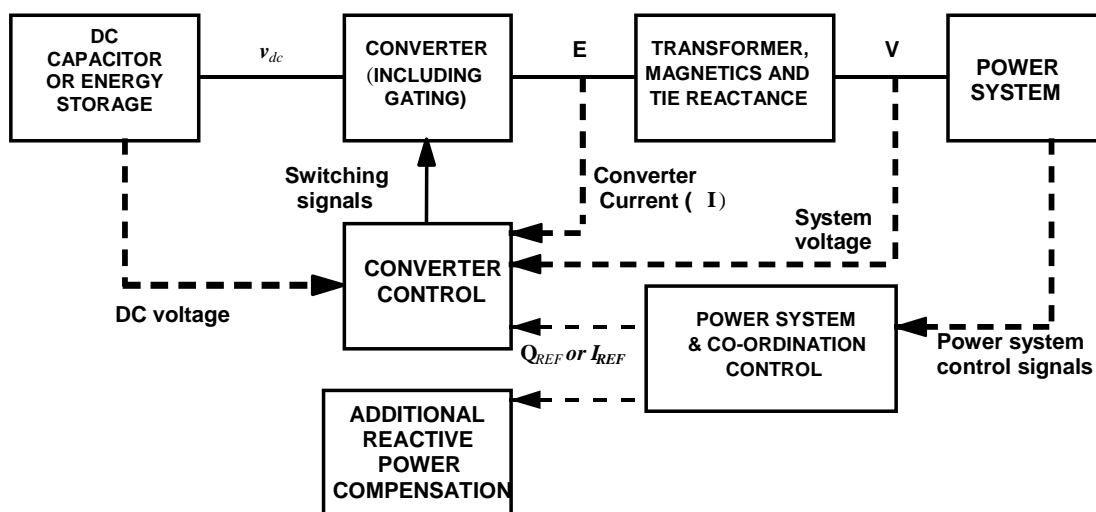

Figure. 3.3: Overview of the STATCOM Control for transmission applications.

3.4 BASIC TOPOLOGY AND OPERATING PRINCIPLE OF STATCOM

In this Section only the general ideas to give the necessary information for understanding the control schemes in the Appendix B and used later in Chapter 4, Section 4.5 will be discussed. Fundamental concepts of STATCOM are discussed in detail in Chapter 2 of this publication as well as in Chapter 2 of reference [3-5].

The voltage-sourced converter is the basic building block of a STATCOM. The STATCOM may consist of one or more converters connected in series and/or parallel, via reactors or transformers. Different topologies of installed STATCOM equipment are described in reference [3-6].

As described in detail in Chapter 2, Figure 3.4 shows the topology of a simple two-level 6-pulse converter consisting of six self-commutated semiconductors (GTOs or IGBTs) with anti-parallel-connected diodes. The switching states of the devices determine the terminal of the d.c. capacitor to which the a.c. side terminals are connected at any one instant. The converter can be modelled with three switches as shown in Figure 3.5.

Depending on the converter type different strategies such as Pulse Width Modulation (PWM) as shown in Figure 3.6, or optimised pulse patterns are applied to achieve a desired voltage waveform. In a good approximation the converter can be modelled as a three-phase voltage source.

When applying space vector representation as described in the Appendix B and in Section A.2.1 of reference [3-5] the converter model can be further simplified to a single voltage source. This approach has also been used in Appendix B of this publication. As will be explained in detail in Chapter 4, an ideal compensator in the form of a current source that completely compensates the voltage fluctuations is initially used in Chapter 4. However, in the EMTDC type simulations in Chapter 4 the STATCOM converter is fully modelled without any simplifications being applied.

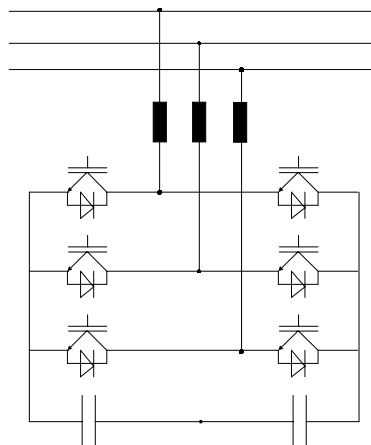

Figure 3.4: Topology of voltage-sourced self-commutated converter with IGBTs coupling to the power system via a reactor.

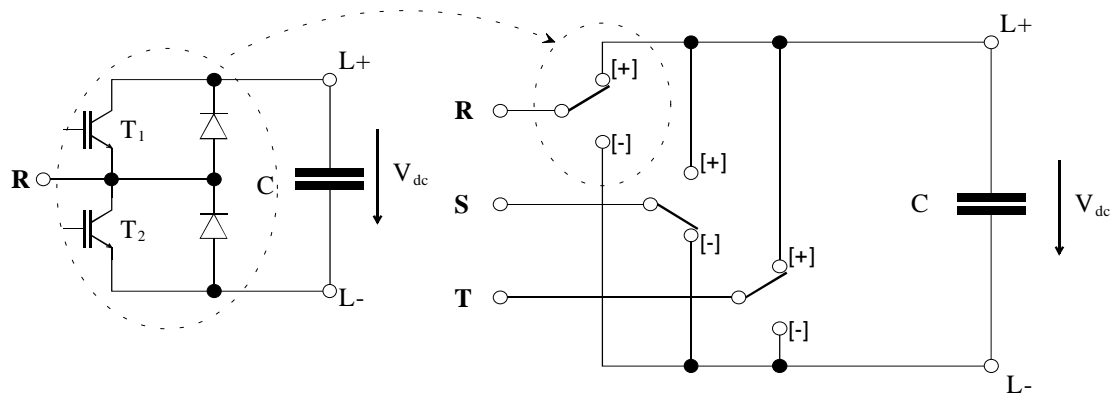

Figure 3.5: Modelling of two-level self-commutated converter with switches.

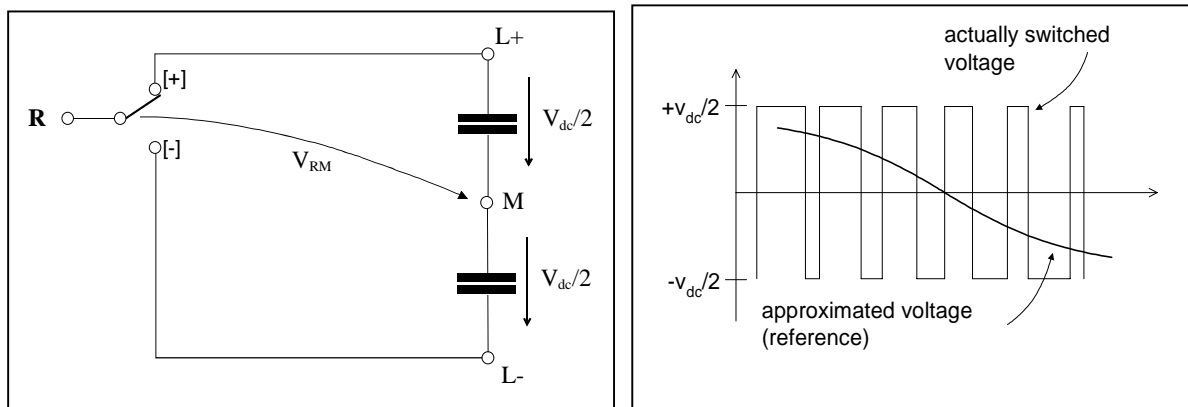

Figure 3.6: Principle of Pulse Width Modulation (PWM).

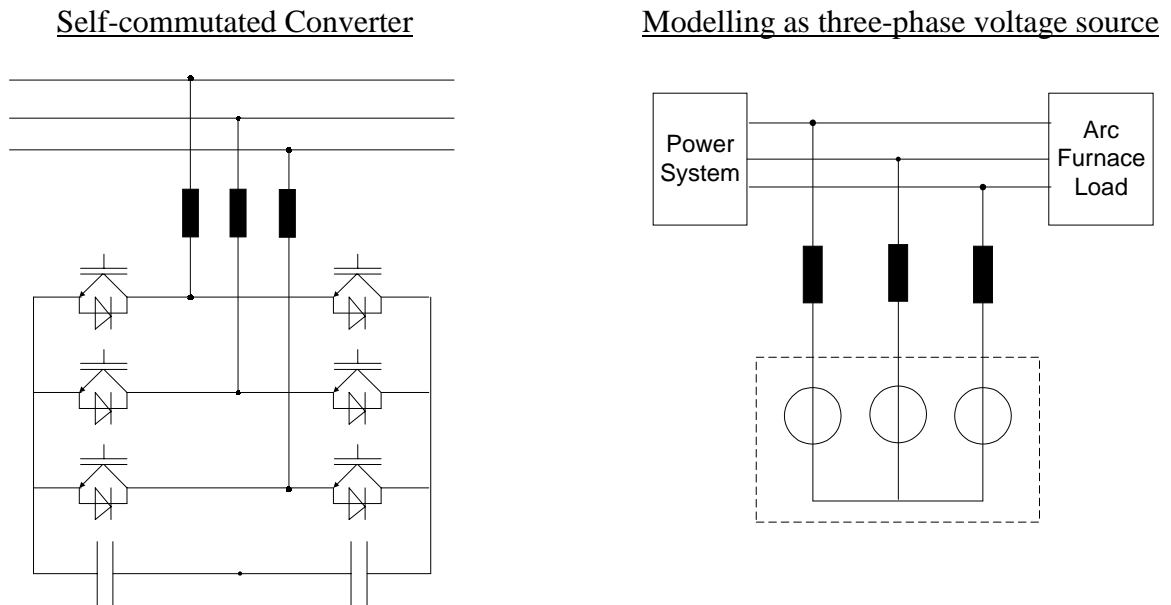

Figure 3.7: Modelling of self-commutated voltage-sourced converter as a three-phase voltage source.

3.5 EXAMPLE OF A STATCOM CONTROL IMPLEMENTATION FOR FLICKER MITIGATION

This section discusses the implementation of a typical flicker control system for the STATCOM. The reader is reminded that the detailed transient simulation results presented in Chapter 4 are generated using this control approach. This control scheme is similar to the first type of control approach described in Section 3.2. In this approach, the STATCOM compensates for rapid variations in the furnace currents and ensures a largely sinusoidal current flow into the a.c. network (power system).

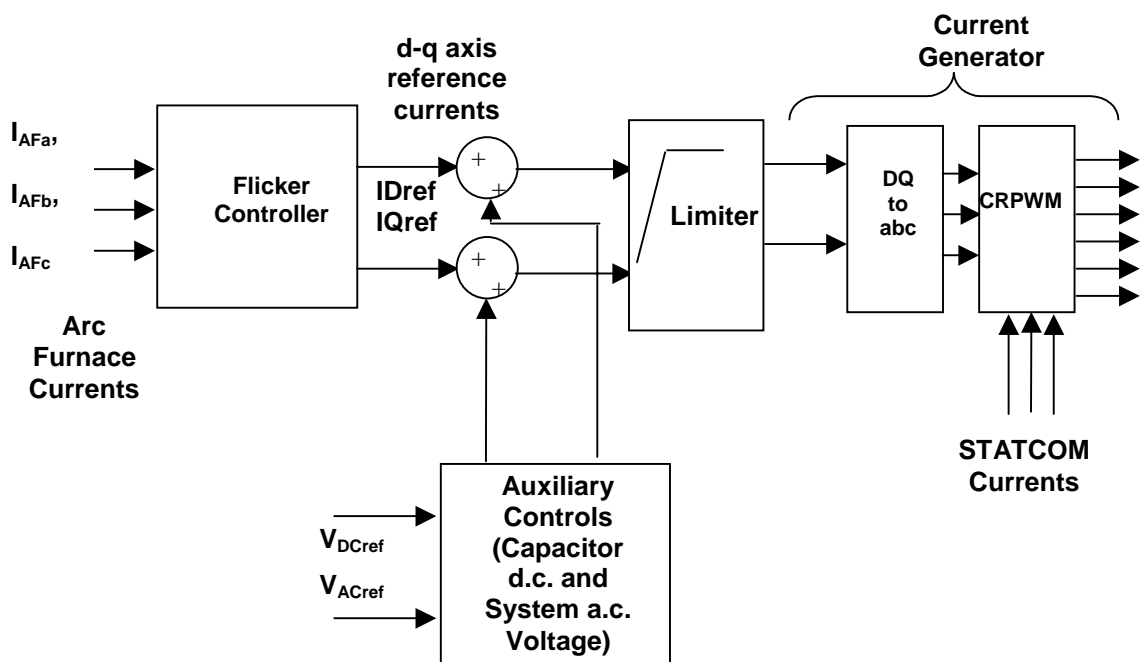

Figure 3.8: A typical approach to STATCOM Control System for flicker mitigation.

Consequently, the d.c. capacitor must be sized so that it can provide for some transient exchange of energy, although over several cycles, the net energy exchange is zero. Figure 3.8 shows a block diagram of the overall control scheme. The flicker control block derives the current reference signals that are necessary for mitigating the flicker. The auxiliary controls provide additional reference current components to achieve the objectives of regulating the capacitor d.c. voltage and the STATCOM's a.c. busbar voltage. The resultant current orders are then passed through the limiter block to ensure that the requested current is within the STATCOM rating. Finally, the current orders are converted back to the phase domain and firing pulses are issued to the STATCOM's semiconductor switches to ensure that the desired current does get injected into the network. A detailed description of these control blocks is provided below.

The Flicker Control Block

The purpose of this block is to create the current reference signals for controlling the flicker. These signals are then passed on to the current controller which results in the STATCOM injecting the appropriate current into the network (power system), thereby resulting in the mitigation of the flicker.

The first step in this process is to determine the fluctuations of the currents around their average fundamental component. This is best achieved by converting the current into the direct and quadrature axis equivalents. The direct or ‘d’ component of the current can be described as that component which causes the flow of real power into the STATCOM (at the point of common coupling), and the quadrature or ‘q’ component is the component that causes the flow of reactive power. The d and q components can be respectively determined, by resolving the phase currents into their projections along the positive sequence voltage phasor and on an axis perpendicular to it. If the current waveform is smooth balanced and harmonic free then the resulting d and q quantities are thus transformed into non-time varying d.c. quantities. In reality, however, the d and q components would not be smooth. Subtracting the d.c. component of d and q from their instantaneous values is thus a convenient mechanism for determining the variation of current around its average value.

An efficient algorithm to detect the d and q components from the three phase (a,b,c) quantities uses the intermediate step of first removing the zero sequence component and generating the 90° displaced time domain quantities α and β via the “Clarke Transformation”, as shown in Equation 3.1. The d and q quantities are then obtained by taking the projections of α and β along a rotating phasor locked in phase with the positive sequence a.c. system voltage, as indicated by the second equation. The phase locked loop (PLL) provides the reference angle for the system positive sequence phasor.

$$\begin{bmatrix} I\alpha \\ I\beta \end{bmatrix} = \frac{2}{3} \begin{bmatrix} 1 & -1 & -1 \\ 0 & \frac{\sqrt{3}}{2} & -\frac{\sqrt{3}}{2} \end{bmatrix} \begin{bmatrix} Ia \\ Ib \\ Ic \end{bmatrix}; \quad \begin{bmatrix} Id \\ Iq \end{bmatrix} = \begin{bmatrix} \cos(\theta) & \sin(\theta) \\ -\sin(\theta) & \cos(\theta) \end{bmatrix} \begin{bmatrix} I\alpha \\ I\beta \end{bmatrix} \quad \text{Eqn. 3.1}$$

The control implementation for this block is shown in Figure 3.9, with the phase currents of the arc furnace labelled as I_{AFa} , I_{AFb} and I_{AFc} . The d and q components (I_{AFd} and I_{AFq}) can be filtered with an averaging filter that calculates the long term average of these quantities using a typical sliding window of about a few tenths of a second (0.5 s in our case). The signals thus obtained (I_{davg} , I_{qavg}) can be subtracted from the instantaneous measurements, thus yielding the short-term fluctuations that need to be compensated (I_{dref} , I_{qref}). Often, an additional passive filter is present at the point of common coupling. The actual control signal to the STATCOM current controller therefore requires the further subtraction of the d and q components of the passive filter currents.

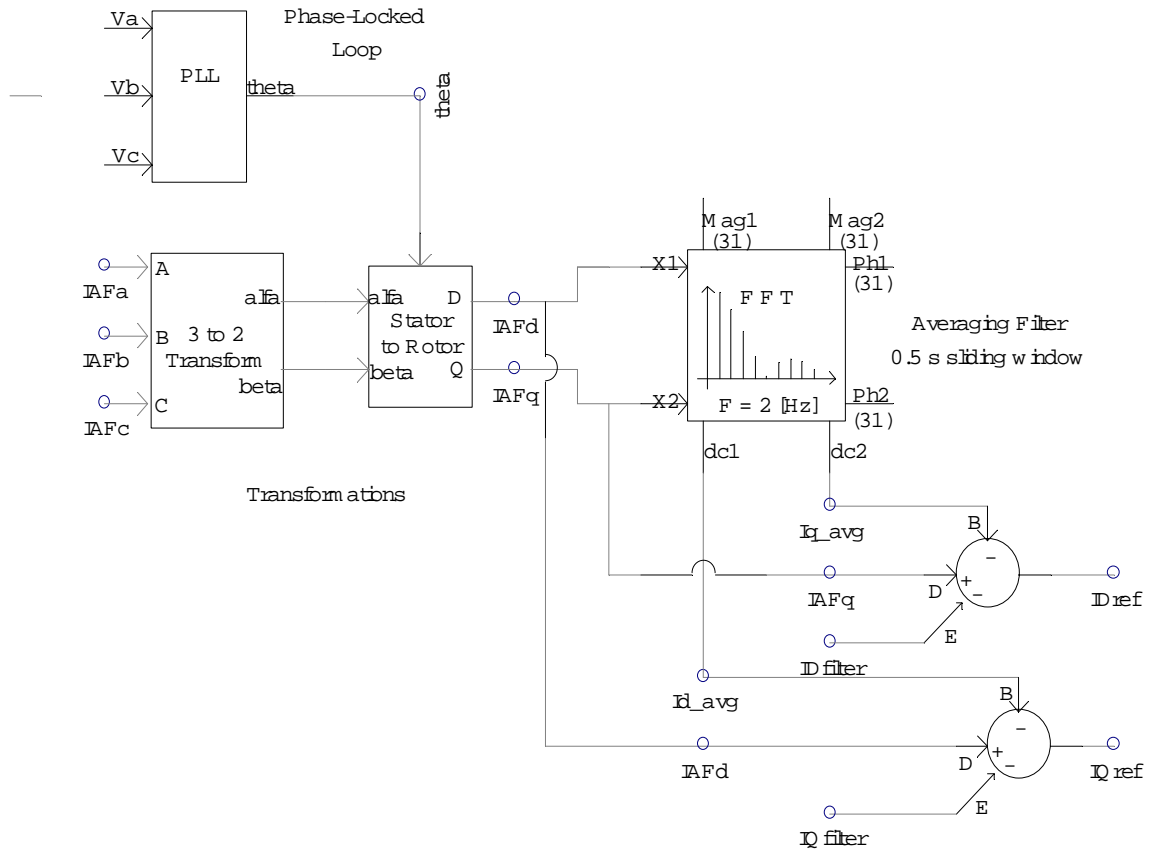

Figure 3.9: Generation of current orders for the STATCOM controller.

Figure 3.10 is instructive in understanding the processes involved. If the phase currents were balanced and harmonic free, as shown in the first few cycles of the waveform, the d and q components are constant (purely d.c.), and consequently the differences from their long term averages are zero. However, if some ripple is introduced as shown in the latter part of the waveform, the d and q components now show variations around their mean. The precise amount of variation is depicted in the last waveform in the series. If this variation is compensated by injecting the same amount of current from the STATCOM, then the a.c. network (power system) would be required to provide only the steady state component, thereby eliminating the flicker. In practice due to limitations in measurement and implementation, precise cancellation is not normally achievable, and some amount of flicker will be manifest.

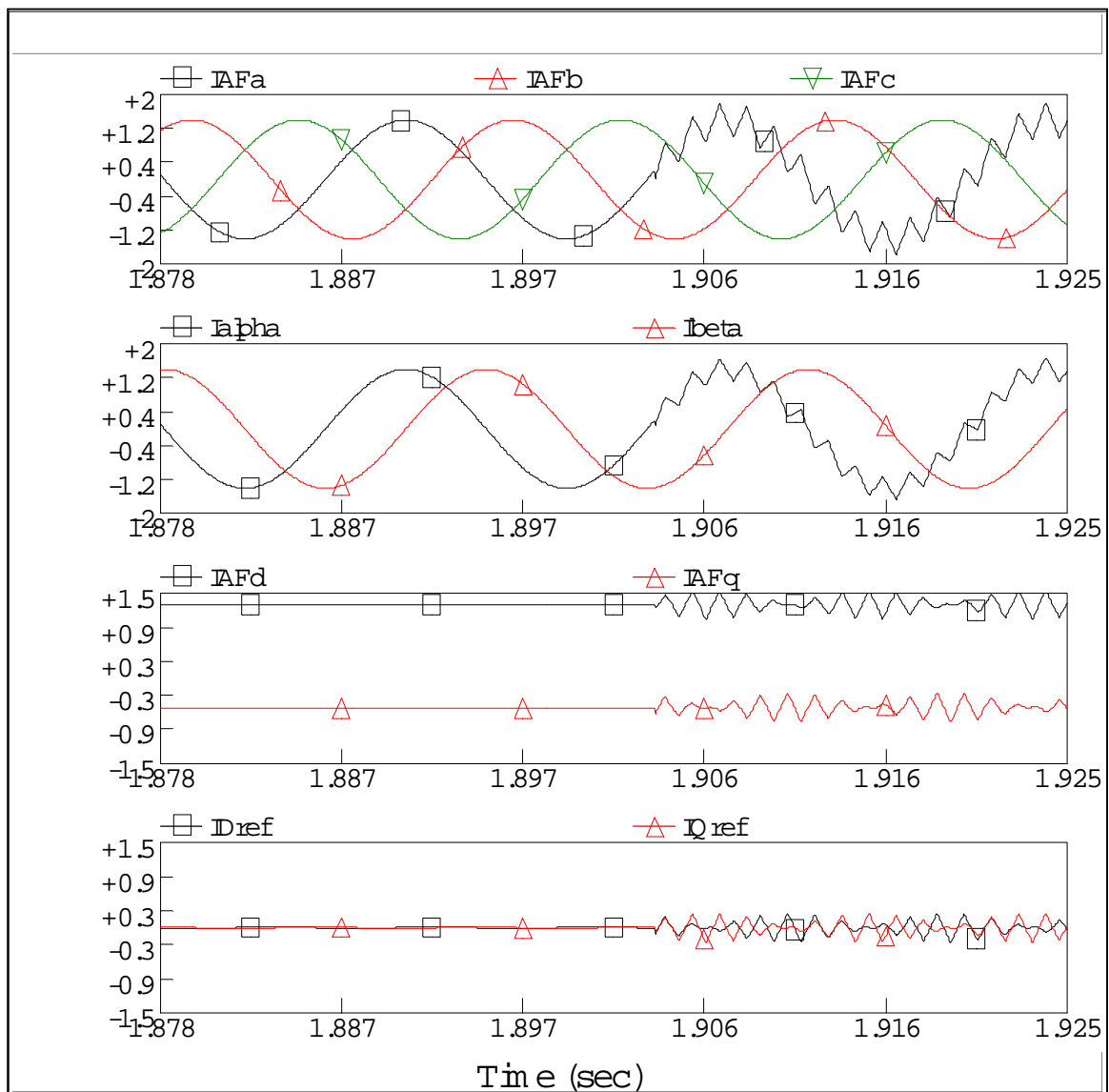

Figure 3.10: Phase (a,b,c) and transformed (α and β), (d and q) and reference currents in the STATCOM flicker controller.

Auxiliary Controls

Although the principal purpose of the STATCOM is to control the flicker, additional control loops are necessary to ensure proper operation. One such control loop, shown schematically on the left-hand side in Figure 3.11 is required to keep the d.c.-side (d.c. capacitor) voltage of the STATCOM at its rated value. This control loop consists of a proportional-integral controller, which acts on the voltage error from the rated value. The output of the loop (D_{id}) is an increment to the d axis current reference, thereby affecting the flow of real power into and out of the STATCOM. This real power flow is responsible for charging or discharging the d.c. capacitor with a view to regulating its voltage.

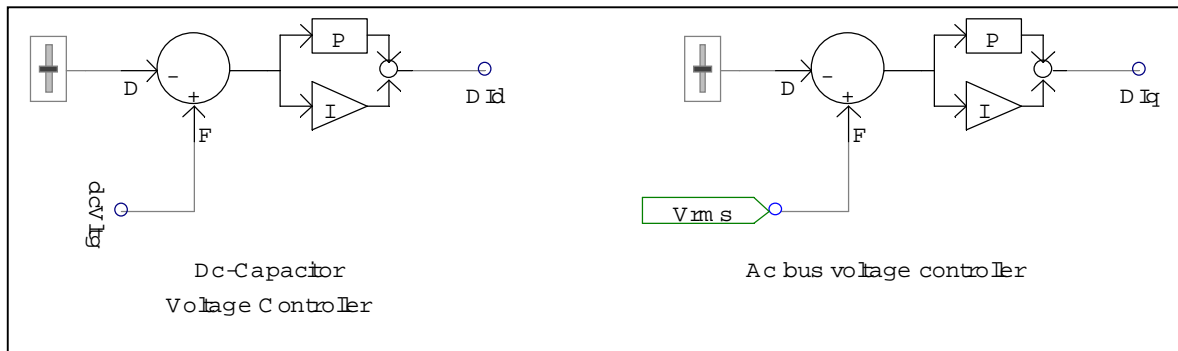

Figure 3.11: Auxiliary control blocks for d.c. capacitor and a.c. voltage regulation.

An additional control loop is sometimes required to regulate the a.c. side voltage of the STATCOM as well. As the voltage can be controlled by adjusting the reactive power output of the STATCOM, this loop adds an incremental quantity ($D_i q$) to the q-axis current reference.

In practice these auxiliary control loops are usually designed to have small gains and are thus slower acting such that the principal objective of flicker control is not compromised. Consequently, the control objectives of these auxiliary control loops are not tightly controlled in the transient states during operation. For example, the d.c. capacitor voltage may show moderate variations during transient operation.

Current Limiter

The current limiter ensures that the current order requested by the control system does not exceed the maximum current rating of the STATCOM. As shown schematically in Figure 3.12, this is achieved by converting the d and q axis signals to polar form and limiting the magnitude of the resultant control signal. It is worth to note that the total current order is the sum of the current orders from the flicker control block and the auxiliary control blocks discussed above.

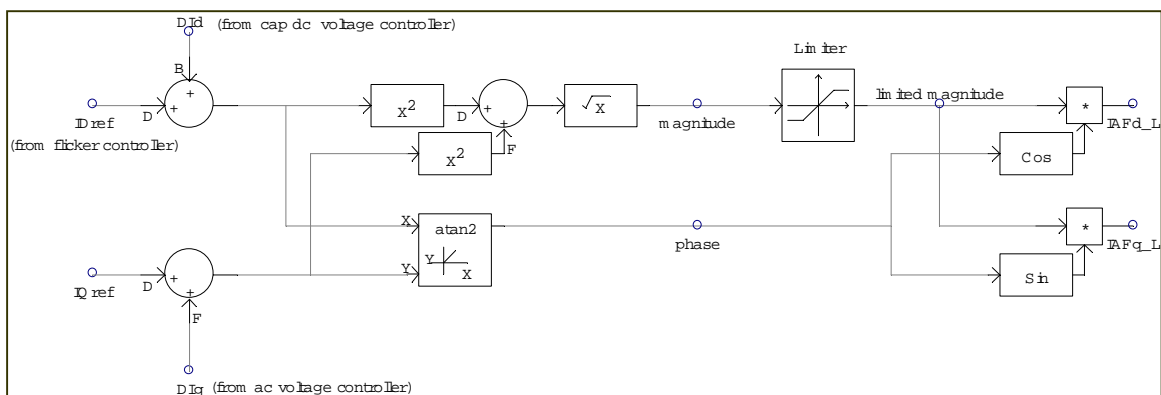

Figure 3.12: Current limiter control block.

For the conversion of current to and from d-q to polar (magnitude-phase) form are accomplished using the well known relationships (with I_m , and θ as the magnitude and phase, respectively):

$$\begin{aligned} I_m &= \sqrt{I_d^2 + I_q^2}, \quad \theta = \arctan(I_q / I_d); \\ I_d &= I_m \cos(\theta), \quad I_q = I_m \sin(\theta); \end{aligned} \quad \text{Eqn. 3.2}$$

Current Reference Pulse Width Modulated (CRPWM) based Current Generator

The d and q reference currents, which are the outputs from the current limiter, are converted into the corresponding phase quantities by using the inverse transformation to Equation 3.1 above.

$$\begin{bmatrix} I_\alpha \\ I_\beta \end{bmatrix} = \begin{bmatrix} \cos(\theta) & -\sin(\theta) \\ \sin(\theta) & \cos(\theta) \end{bmatrix} \begin{bmatrix} I_d \\ I_q \end{bmatrix}; \quad \begin{bmatrix} I_a \\ I_b \\ I_c \end{bmatrix} = \begin{bmatrix} 1 & 0 \\ -1/2 & \sqrt{3}/2 \\ -1/2 & -\sqrt{3}/2 \end{bmatrix} \begin{bmatrix} I_\alpha \\ I_\beta \end{bmatrix} \quad \text{Eqn. 3.3}$$

In Figure 3.13, these reference currents are labelled I_{a_ref} , I_{b_ref} and I_{c_ref} respectively. The current reference pulse width modulated (CRPWM) controller is one method that produces the desired currents. In the figure, only the firing pulse generator for phase a is shown. The firing pulse generators for phases b and c are similar. The controller consists of a comparator that controls the actual current with the reference current and passes it to a comparator with hysteresis characteristics. The overall effect of doing this is that the generated “on” signal at the points “g1” and “g4” (for the STATCOM IGBT switches T1 and T4) obey the following characteristic:

$$\begin{aligned} I_{actual} > I_{a_ref} + hy &\Rightarrow g1 = 0, \quad g4 = 1 \\ I_{actual} < I_{a_ref} - hy &\Rightarrow g1 = 1, \quad g4 = 0 \end{aligned} \quad \text{Eqn. 3.4}$$

where,

I_{actual} = the measured phase current; and
 hy = the width of the hysteresis band.

Figure 3.14 shows typical waveforms, which explain the operation of this controller. Assume for example that I_{actual} has just reached the lower threshold of the hysteresis. The “on” signal at “g1” goes high and turns the upper IGBT switch T1 on. This connects the phase “a” of the STATCOM to the positive d.c. busbar, which causes the phase “a” current to increase. The increase continues until the upper threshold of the hysteresis is reached, at which time “g4” goes high and turns the lower IGBT switch T4 on. This results in a reduction in the phase “a” current. Using this scheme, the phase current is confined to an arbitrarily small hysteresis band about the desired reference value, and thus essentially reproduces the desired reference value. Of course, the practical limit on the minimum time between switchings imposes the lower limit on the width of this hysteresis band.

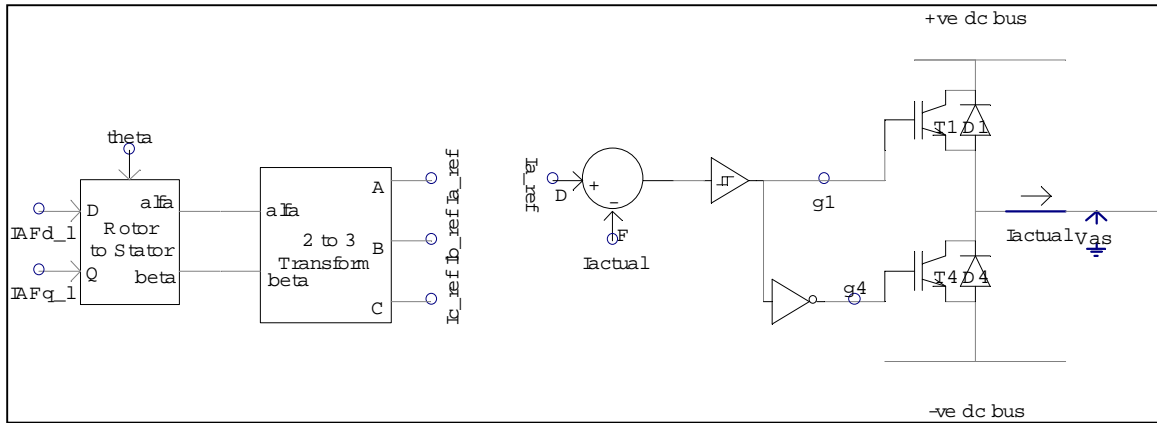

Figure 3.13: Current Reference Pulse Width Modulated (CRPWM) controller.

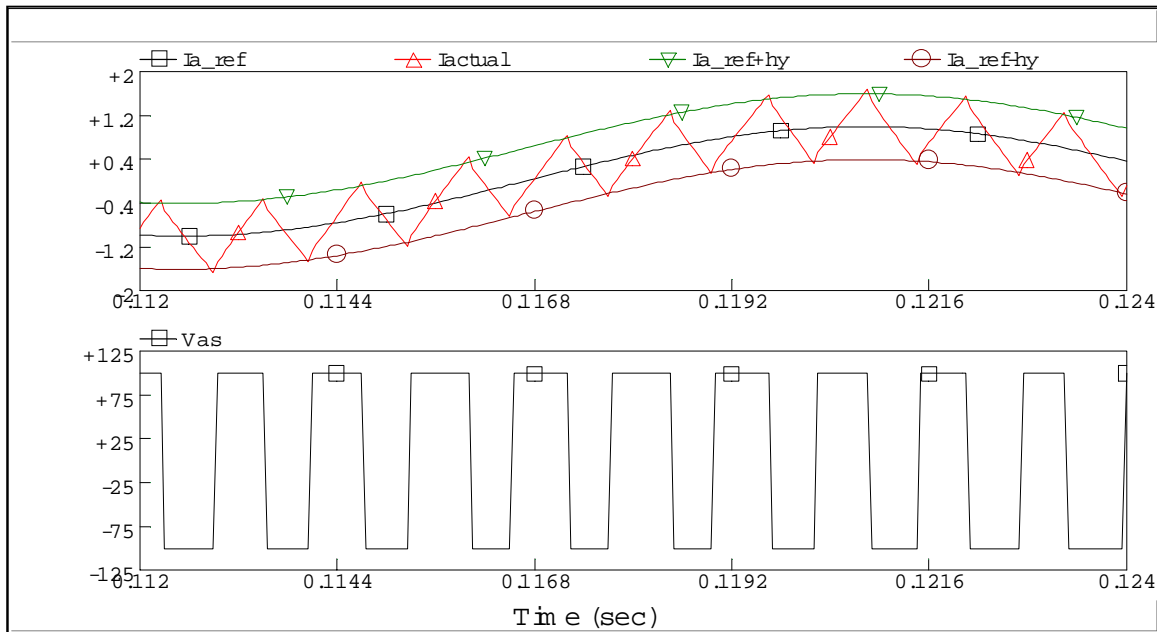

Figure 3.14: CRPWM controller current and voltage waveforms.

The CRPWM controller produces currents, which are essentially equal to the desired reference currents, which in turn were the outputs of the flicker control and other auxiliary control loops. Consequently, the STATCOM action of injecting these currents into the network reduces the flicker as well as achieves the auxiliary objectives.

3.6 OTHER METHODS OF STATCOM CONTROL IMPLEMENTATION FOR FLICKER MITIGATION

This STATCOM control example given in the previous Sections is illustrative of only one typical control method for a STATCOM designed for the arc furnace flicker mitigation. This method is used later in the simulations detailed in Chapter 4. It should be noted however, that other approaches to control do exist. Appendix B at the end of this document provides additional information on D-Q based compensation and discusses some other control implementations.

3.7 REFERENCES

- [3-1] Larsson, T.: “Voltage Source Converters for Mitigation of Flicker Caused by Arc Furnaces”, Dissertation at School of Electrical Engineering and Information Technology (KTH) at University of Stockholm, ISBN 91-7170-274-1, 1998.
- [3-2] Depenbrock, M.: “Kompensation schnell veränderlicher Blindströme”, ETZ-A Bd. 98 (1977) H. 6.
- [3-3] Klinger, G.: Steuer- und Regeleinrichtung einer selbstgeführten Kompensations-Stromrichterschaltung”, ETZ-A Bd. 98(1977), H. 6.
- [3-4] Le, T. N.: Kompensation schnell veränderlicher Blindströme eines Drehstromverbrauchers”, ETZ Archiv Bd. 11 (1998) H. 8.
- [3-5] Erinmez, I. A.; Foss, A.: “Static Synchronous Compensator (STATCOM)”, Technical Brochure No 144 of CIGRE Working Group 14.19, 1999.
- [3-6] Paserba, J.; Reed, G.; Takeda, M.; Aritsuka, T.: “FACTS and Custom Power Equipment for the Enhancement of Power Transmission System Performance and Power Quality”. VII SEPOPE, Curitiba, Brasil, 21.-26. 5. 2000.

Chapter 4. STATCOM RATING AND PERFORMANCE CONSIDERATIONS

Prepared by Matti Lahtinen, Ani Gole and Dan Kell

4.1 INTRODUCTION

Previous Chapters have dealt with the need to compensate the arc furnace and other non-linear loads to reduce flicker to acceptable levels, the international standards and guidance available to utilities, utilisation and performance characteristics and control of STATCOM for flicker reduction purposes. This Chapter deals with the practical utility aspects from estimating the flicker levels of an arc furnace installation at the connection planning stage.

4.2 FLICKER ESTIMATION FOR A NEW ARC FURNACE

The short-term flicker severity index of an arc furnace to be connected to an electric power system can be estimated at the connection planning stage by the utility using the following equation. This equation which provides an early indication was derived through observation of many arc furnaces in operation as described in reference [4-1].

$$P_{st99\%} = \frac{S_{cef} \cdot FR}{S_{ccn}} \cdot K_{st}$$

where,

S_{ccn} = the minimum fault level at the connection point to the power system;

S_{cef} = the fault level of arc furnace assuming infinite fault level of connection point;

FI = the Flicker Improvement Ratio of Compensator [$FI = P_{st\ without} / P_{st\ with} = 1 / FR$];

FR = the Flicker Reduction Factor of Compensator [$FR = P_{st\ with} / P_{st\ without} = 1 / FI$];

K_{st} = an empirical factor dependent upon the arc furnace operation, varying in the range 41 to 135 as described in reference [4-1];

$P_{st99\%}$ = the “short term flicker severity index”, not to be exceeded with 99% probability.

As a first approximation, by using $K_{st} = 75$ a first estimate of the short-term flicker severity index $P_{st99\%}$ of an arc furnace to be connected to an electric power system can be obtained. Some standards (e.g. CENELEC) specify the short-term flicker severity index $P_{st95\%}$, i.e., the short-term flicker severity index not to be exceeded with 95% probability, instead of $P_{st99\%}$. In such cases the approximate conversion relationship between the two indexes given below

$$P_{st99\%} = 1.1 P_{st95\%}$$

should be used to obtain the estimate of the quoted index.

The Flicker Reduction Factor (FR) figure applicable to various types of compensator is usually not defined in international standards and guidance. The value of FR will probably vary slightly dependent upon the criteria used, i.e., $P_{st99\%}$ or $P_{st95\%}$, to specify the arc furnace flicker performance required by the utility, be slightly different. However, at the early stages of connection planning by the utility such small differences need not be taken into account. In the following sections of this Chapter the values of Flicker Reduction applicable to various types of compensators will become clearer.

4.3 ANALYSIS OF UNCOMPENSATED ARC FURNACE

In order to carry out a fuller assessment of the conditions pertaining to the connection of an arc furnace to the power system the utility needs to analyse the active and reactive power demand of an uncompensated arc furnace as well as the electrical parameter data related to the system and the arc furnace at the connection point to the system.

The following example illustrates the type of electrical parameter data necessary for this purpose. The figures quoted are relevant to a particular installation based upon the author's experience. In this example, advantage was taken by the author's utility to carry out calculations and measurements on an existing arc furnace of 80MVA nominal rating while planning the connection of an additional arc furnace of 160MVA to a 110kV system was being considered. The following electrical parameter data expressed in per unit (p.u.) on an 80MVA and 110kV base applies to the existing connection point and the arc furnace.

HV network impedance	$X_{110kV} = 0.0421$ p.u.
	$S_{ccn} = 1900$ MVA
Impedance of network transformer	$X_{TI} = 0.15$ p.u.
Series reactor	$X_s = 0.136$ p.u.
Furnace transformer	$X_{T_AF} = 0.077$ p.u.
Furnace impedance	$X_{AF} = 0.302$ p.u.
The fault level of arc furnace	$S_{ccf} = 120$ MVA
Predicted short term flicker severity index without compensator on 110 kV bus	$P_{st99\%} = 4.7$
Predicted short term flicker severity index without compensator on 20 kV bus	$P_{st99\%} = 22.0$

It should be noted that the furnace transformer reactance given above corresponds to the reactance at the highest tap position i.e., at the highest voltage value. The configuration of the actual arc furnace installation considered in this example is given in Figure 4.1 together with the SVC type compensator connected for flicker reduction purposes. As will be described later extensive measurements were carried out on this specific installation with and without the compensator in operation to obtain a full assessment of the Flicker Reduction Factor obtainable for the particular network connection and arc furnace configuration.

Given the above electrical parameter information the arc furnace operating diagram shown by the solid and dashed lines on Figure 4.2, corresponding to the maximum and the minimum tap positions of the arc furnace transformer, can be obtained by calculation. In a similar manner it is possible to calculate the maximum values of real power at other major on-load tap-changer positions. Since the reactive power consumed by the furnace is also influenced by the furnace operational regime information on the maximum power consumption must be requested from arc furnace manufacturer to confirm the calculations made by the utility.

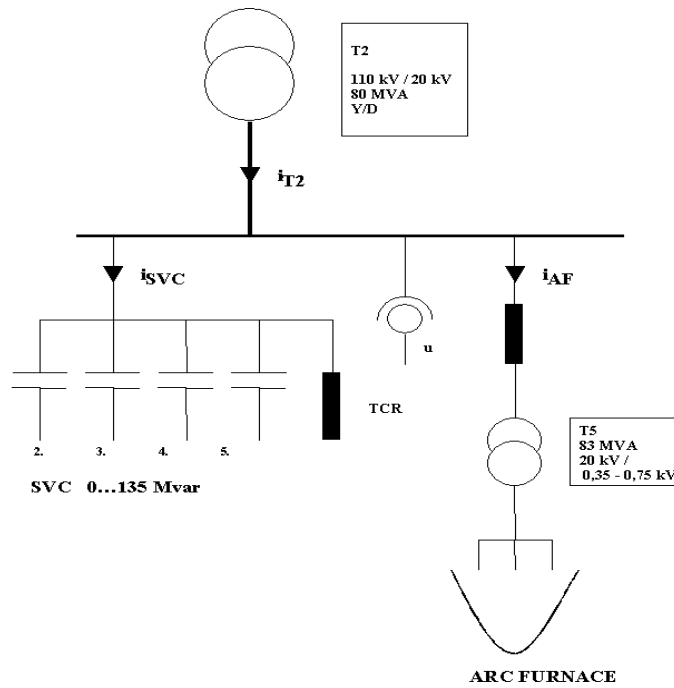

Figure 4.1. The single line diagram of the arc furnace installation and the associated SVC compensator indicating the measured currents and voltages. The SVC compensator is a thyristor controlled reactor with filters tuned to 2nd, 3rd, 4th and 5th harmonic.

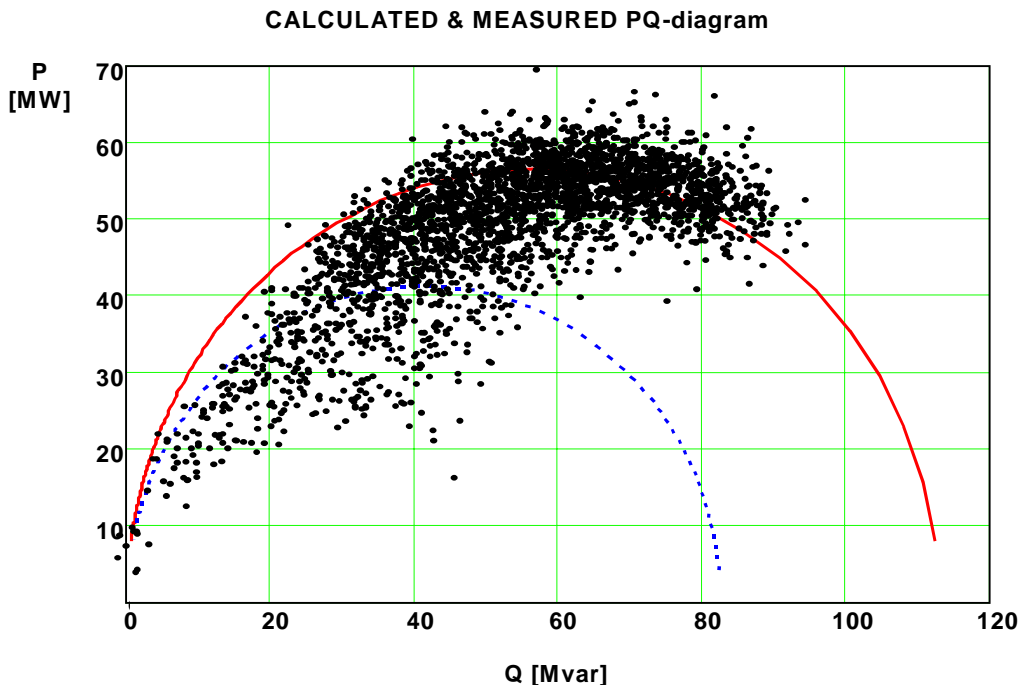

Figure 4.2. The calculated PQ-circle diagram of the example arc furnace at rated voltage assuming a purely resistive arc and the measured highest one cycle P and Q values during one minute periods of furnace operation at peak power.

The quantities measured during furnace operation and shown in Figure 4.1 were the:

- arc furnace phase currents;
- arc furnace phase voltages;
- transformer T2 currents; and the
- SVC phase currents.

The 3000 scatter points on Figure 4.2 each correspond to the average of measurements taken over each fundamental frequency cycle i.e., each scatter point represents the average of each P and Q measurement taken over a 20 msec period, for one minute of arc furnace operation. From this figure it is clear that the real power reaches a maximum value at power factor (pf) around 0.7pf suggests that operation at much higher values of reactive powers are not economical from a furnace design and melting point of view. In this example for 97% of the furnace operation time the reactive power is below 70 Mvar. The most likely reason for points exceeding the calculated PQ circle is the overvoltages experienced due to the overcompensation by the SVC at certain operational periods.

During the measurements simultaneous samples were recorded at a sampling frequency of 2000 Hz for 6 different melting periods like the one illustrated in Figure 4.3. From this basic data all the analysis reported in this Chapter was carried out.

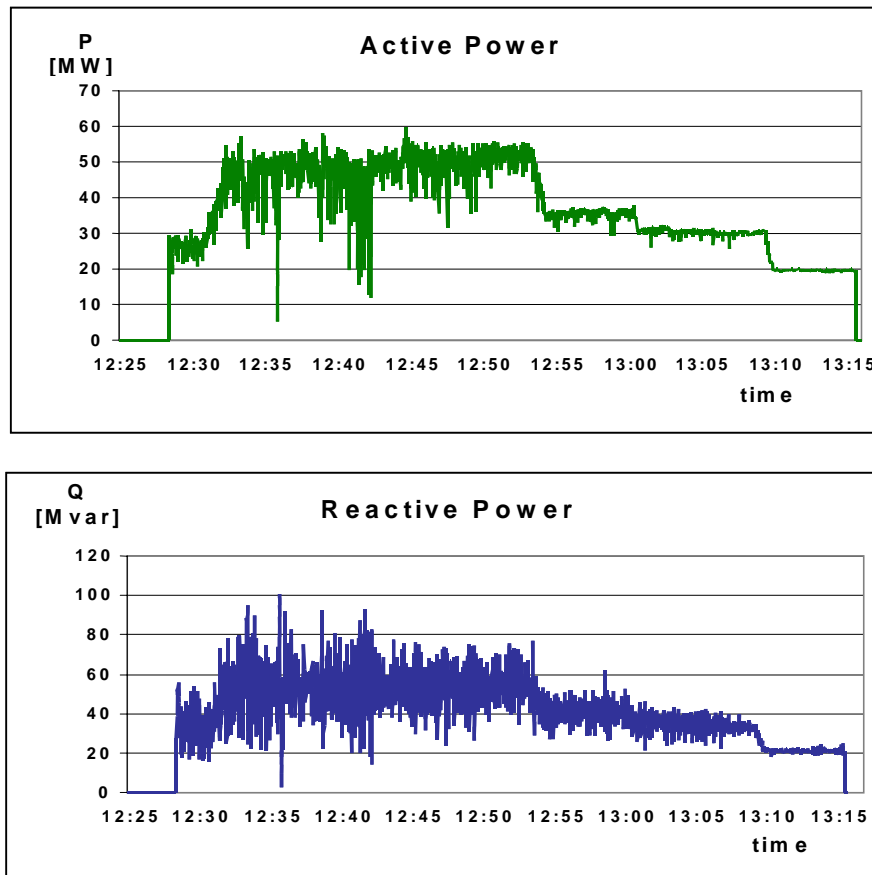

Figure 4.3. The recorded active and reactive powers of the arc furnace for one typical melting period.

Whilst the recorded active and reactive power traces in Figure 4.3 illustrate the progress of the melting process, from a compensation dimensioning point of view cumulative probability of active and reactive powers provide a more useful indicator. These percentage probability values (F_{P_j} and F_{Q_i}) for one typical melting period are plotted against the real and reactive power of the arc furnace in Figure 4.4. From these curves it can be seen that for 95% of the melting period the active power is below 52 MW and reactive power is below 67 Mvar.

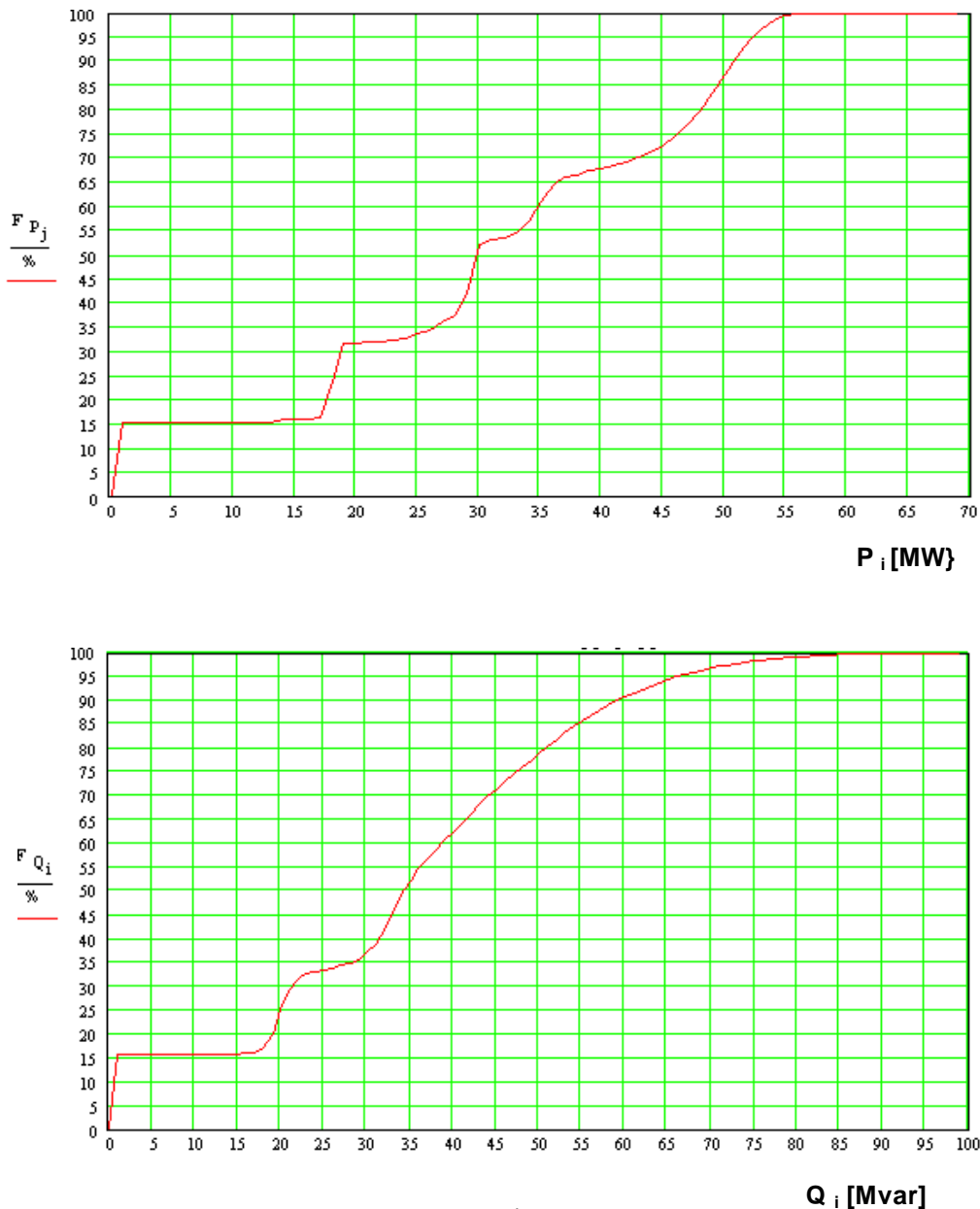

Figure 4.4. Cumulative probability of active (upper figure) and reactive (lower figure) power of the arc furnace for one typical melting period.

Figure 4.5. clearly demonstrates the effect of the resonances between the tuned filters of the SVC and power system. The current components to grid are higher than the arc furnace currents at frequencies: 80 Hz, 110 Hz, 170 Hz and 210 Hz.

The exact functionality of the second and fourth harmonic filters installed with the SVC may have altered with the development of the power system resulting in changes to the harmonic impedance of the system and methods of controlling the SVC. The arc furnace produces some even harmonics, but mostly interharmonics, which cannot be filtered out totally by passive filters. If only one particular frequency causes problem, this can be eliminated by tuned filter. However, there is always the possibility that this may cause another resonance problem at another frequency. The TCR does produce even harmonics, if controlled on a half cycle basis and these require filtering. In this particular case from the recorded measurements the parallel resonance of the 2nd harmonic filter with the system at around 80 Hz, is observable and this tends to amplify the magnitude of the flicker.

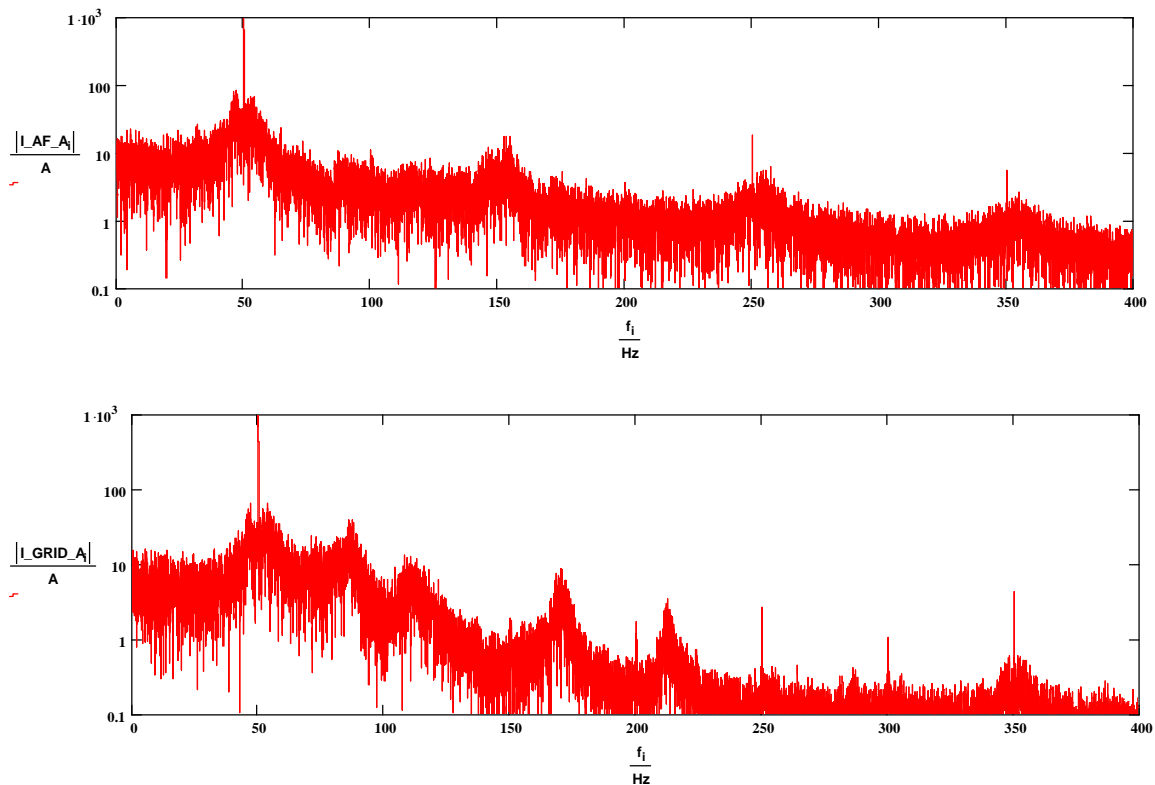

Figure 4.5. Fast Fourier Transform (FFT) of the arc furnace current I_{AF} (upper curve) and the current to the power (grid) system I_{GRID} (lower curve).

Figure 4.5 also illustrates another aspect of the limitations of the TCR for flicker reduction. The TCR produces a reactive compensation effect at frequencies less than 10 Hz. due to its inherent dynamic characteristics. For disturbances containing higher frequencies such as flicker, the TCR has no compensation effect and additionally tends to amplify the disturbances. Thus the components of the arc furnace flicker from 10 Hz to 50 Hz are amplified by the TCR. In this particular installation this coincides with the parallel resonant frequency of the Second Harmonic filter which is between 75 Hz and 100 Hz., i.e., 25 Hz flicker disturbance superimposed on the 50Hz power frequency current produces 75 Hz current components.

Figures 4.6. and 4.7 demonstrate the rapid change of the arc furnace active and reactive power. In Figure 4.6 the three phase active and reactive powers were calculated from the recorded sampled data for every half millisecond. The reader's notice is drawn to the large variations in active and reactive power even within one cycle at power frequency. This is a clear illustration of the challenge posed by the arc furnace to the compensator control system in terms of the required speed of response in reducing the flicker.

The distortion of arc furnace current is exceptional compared any other device as illustrated in Figure 4.5. Perhaps a more demonstrative picture can be obtained if we analyse current components other than fundamental. This analysis takes into account frequency components both above and below the fundamental frequency. The frequency components up to $\pm 20\text{Hz}$ of the fundamental are very important from flicker point of view. This component can be called total distortion current and calculated by $I_d = \sqrt{I^2 - I_1^2}$, where I_1 is fundamental frequency component. The result is shown in Figure 4.7. It is evident that those low frequency components play major role and therefore the control system must be capable to faithfully compensate these currents to mitigate flicker. Compensation of higher frequencies is not so important as long as they do not cause meaningful contribution to rms value of voltage.

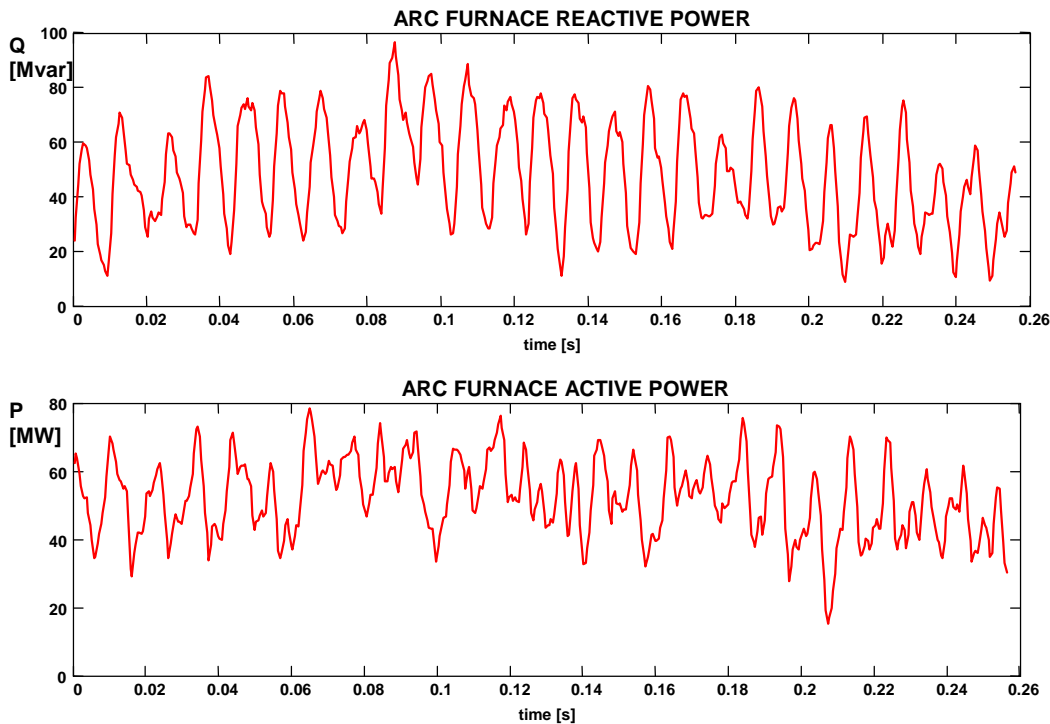

Figure 4.6. Example of instantaneous three phase reactive power and active power of the arc furnace plotted on one sample every half millisecond basis.

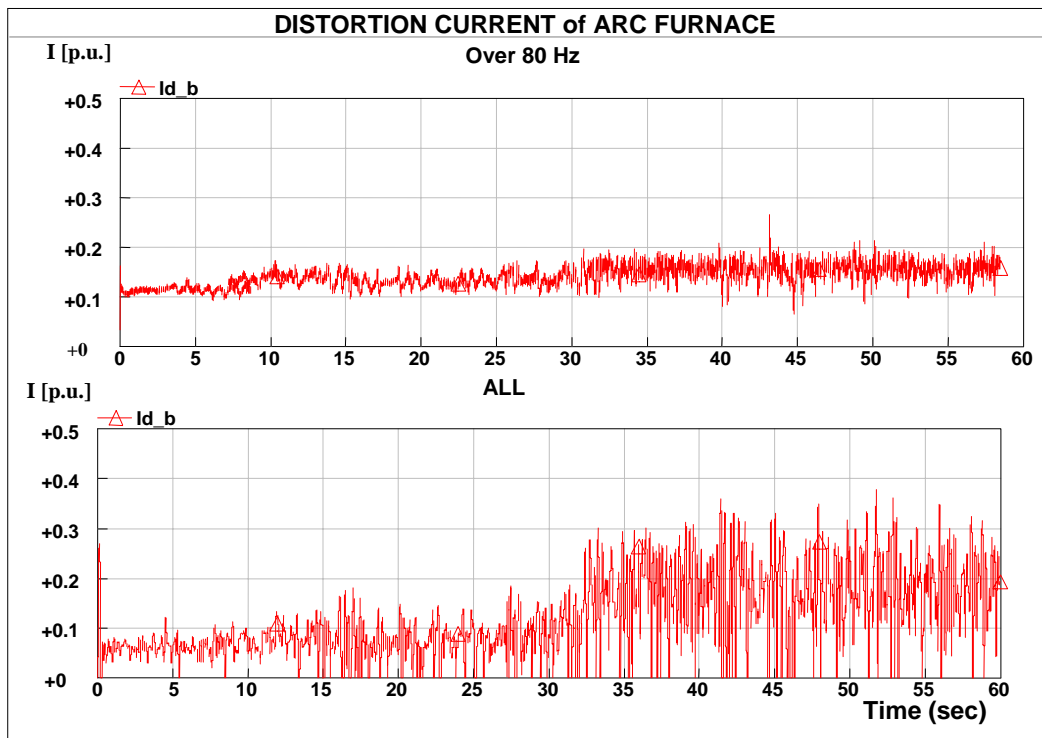

Figure 4.7. Sample of relative current distortion of the arc furnace during one minute of operation. RMS value of arc furnace current with frequencies above 80 Hz (top curve) and all frequencies except the 50 Hz component (bottom curve).

4.4 FLICKER REDUCTION FACTOR CALCULATIONS FOR EXISTING SYSTEM

There are several possible ways to evaluate the flicker reduction performance of existing arc furnace and reactive compensation installations. Classically the flicker performance evaluation has been done using flicker measurements with and without compensator. The major difficulty with this method is that the melting characteristics of every scrap metal charge are different. The consequence is that great number of measurements must be carried out to obtain reliable and accurate results. There are other possible ways to carry out the flicker performance evaluation given that calculation can be accepted as a part of evaluation process and the interaction effects can be assumed to be negligible. Interaction in this context means that the compensator associated with the arc furnace will at times increase the voltage and hence increase the power and current applied to the furnace. If the relative fluctuation of the arc furnace is assumed to be similar under the normal and increased voltage conditions, then the part of flicker compensation will be rendered ineffective for flicker reduction purposes due to the increased current.

One of the possible methods to determine the flicker reduction factor ($FR = P_{st\ with} / P_{st\ without}$) of an existing installation can be described as follows. The short term flicker severity $P_{st\ with}$ is the flicker severity factor calculated for voltage changes caused by the active and reactive power exchange of the arc furnace and its compensator with the power system, through transformer T2 (Fig. 4.1), at a specific system impedance determined by the fault level at the

connection busbar. Whereas $P_{st\ without}$ is flicker severity factor for voltage changes caused by active and reactive powers of arc furnace alone at the same specific system impedance.

Figure 4.8. illustrates $P_{st\ without}$ that was calculated for every minute of the example arc furnace installation. From the figure it is clear that the flicker reduction factor (FR) is fairly constant even though the flicker itself (P_{st}) varies within large range. However it must be kept in mind that the reduction factor should not obviously be constant because the speed of fluctuations varies and the performance of SVC as a function fluctuation frequency varies as well.

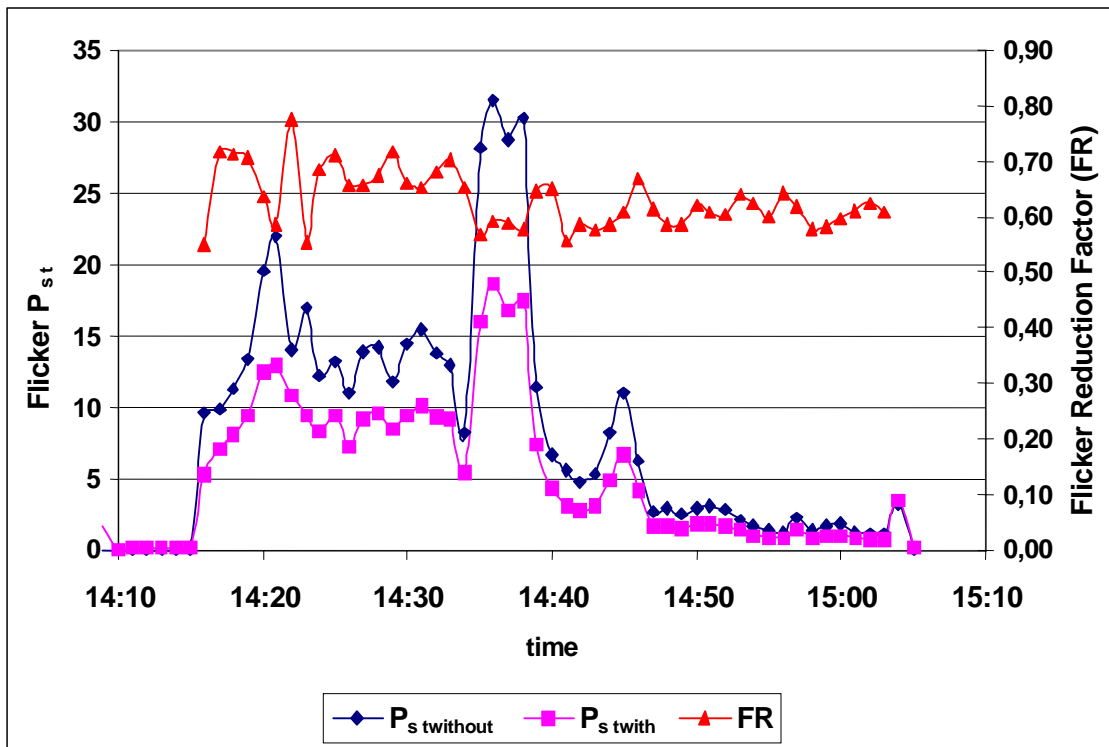

Figure 4.8. The calculated one minute flicker severity indexes $P_{st\ without}$ and $P_{st\ with}$ and flicker reduction factor $FR = P_{st\ with}/P_{st\ without}$ during one melting period of the example arc furnace installation.

Using simulation software, capable of modelling electromagnetic transient phenomena such as the EMTDC, which is capable of simulating the behaviour of reactive compensation equipment including STATCOM, it is possible to use measured data of existing arc furnaces to predict the flicker performance of a future installation, assuming similar type of operation. This simulation concept is diagrammatically illustrated in Figure 4.9.

Let us first examine the evaluation of the existing compensator performance. Feeding the measured three phase voltages to the flicker calculation block the real-time flicker values will be obtained. At the same time we can calculate the phase voltage fluctuations caused by arc furnace currents in the system impedance at the connection point. Calculating the real time flicker due to these voltages as well and forming the ratio we may get a result similar to the one shown in Figure 4.10. The result, reduction factor of compensator is shown for all phases. The result is filtered by first order low pass filter with 5 second time constant. Instantaneous flicker, the three lowest curves, corresponds the output 3 of IEC flickermeter.

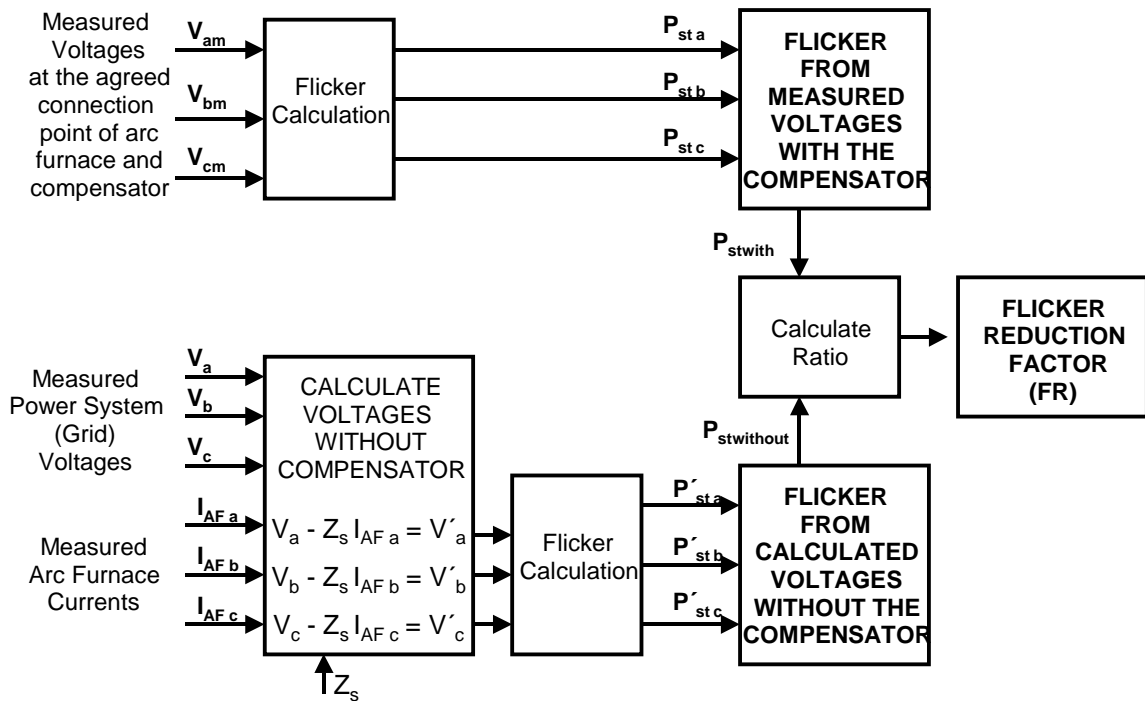

Figure 4.9. The flicker performance measurement and calculation process.

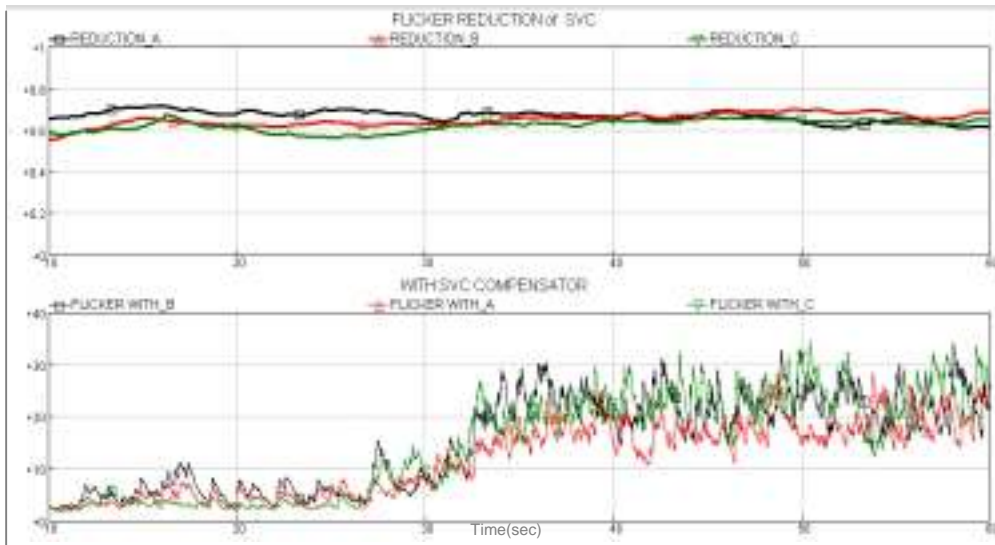

Figure 4.10. The flicker reduction performance calculation result for one minute of arc furnace operation with SVC type compensator. Top curve Flicker Reduction Factor of phases a, b and c and bottom curve instantaneous flicker magnitude at the arc furnace busbar.

4.5 FLICKER REDUCTION FACTOR CALCULATIONS FOR COMPENSATOR WITH LIMITED CAPACITY

Using the measured data for arc furnace and simulating a particular type of compensator the flicker performance for that compensator operating in combination with the arc furnace can

be evaluated using the procedure described in Section 4.3. The calculated values of the Flicker Improvement Ratio for an ideal compensator without any capacity limits and for two other cases of ideal compensator with limited capacity are illustrated in Table 4.1. In this respect an ideal compensator could be defined as a compensator which fully compensates the reactive component of the arc furnace current and the unbalance caused by that current removing all fluctuations in the ± 20 Hz bandwidth around the fundamental system frequency.

Table 4.1 Calculated Flicker Improvement Ratio with an ideal compensator

	Flicker Improvement Ratio (FI)
Ideal compensator with no capacity limits	infinite
Ideal compensator with capacity of 70 Mvar	2,9
Ideal compensator with capacity of 50 Mvar	1,45

From Figure 4.4 it is observed that the reactive power of arc furnace exceeds 70 Mvar for around 3% and exceeds 50 Mvar for about 20-25% of its operating time. It is worth to note that the calculation indicates that an ideal compensator of 50 Mvar rating will yield the same flicker improvement performance as the existing compensation of 135Mvar rating.

In the following simulations a STATCOM has been connected in parallel to arc furnace and its objective is simply minimise the reactive component of grid (power system) current. In this example simulation the compensator consists of fixed 40 Mvar filter and varying capacity STATCOM for the controlled part of the reactive compensation. The STATCOM control system controls the ideal current sources at each phase. A typical simulation result is shown in Figure 4.11.

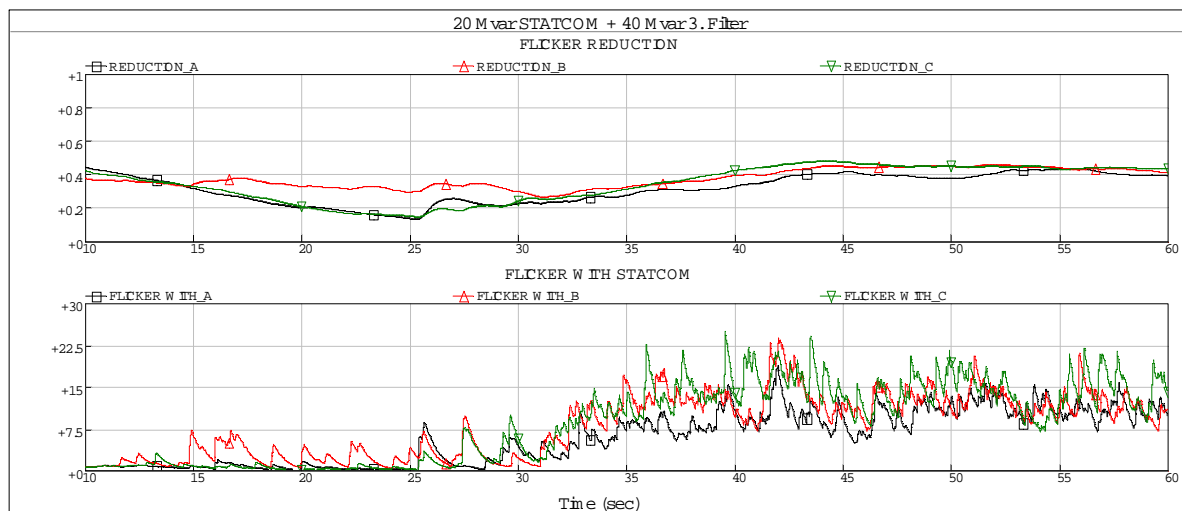

Figure 4.11. Simulated flicker reduction with proposed STATCOM control method of Figure 4.12. The ± 20 Mvar STATCOM in parallel with 40 Mvar third. harmonic filter compensating the reactive power fluctuation only. Top curve Flicker Reduction Factor of phases a, b and c and bottom curve instantaneous flicker magnitude at the arc furnace busbar.

Table 4.2 illustrates the flicker reduction performance obtainable with an ideal STATCOM with varied rating including a passive filter of 40 Mvar fixed rating.

Table 4.2. Ideal STATCOM control model with varied rating

STATCOM Rating (± Mvar)	Passive Filter Rating (Mvar)	Flicker Reduction Factor (FR)	Flicker Improvement Ratio (FI)
20	40	0.44	2.27
25	40	0.31	3.22
30	40	0.25	4.00
35	40	0.17	5.88
40	40	0.08	12.5

The results of a similar study made with a more detailed STATCOM model are given in Table 4.3.

Table 4.3. Simple realistic STATCOM control with varied rating

STATCOM Rating (± Mvar)	Passive Filter Rating (Mvar)	Flicker Reduction Factor (FR)	Flicker Improvement Ratio (FI)
20	40	0.58	1.72
25	40	0.47	2.13
30	40	0.38	2.63
35	40	0.30	3.33
40	40	0.25	4.00

The controls for the STATCOM used in this simulation study are shown in Figure 4.14. First the “instantaneous” direct and quadrature components of the a.c. currents are extracted. The direct component is the one in phase with the positive sequence (fundamental component) phasor of the a.c. bus voltage, and the quadrature component is the one at right angles to this phasor. The reference angle for calculating the d and q components is obtained from a phase-locked loop which tracks the a.c. voltage. These instantaneous components are then subtracted from their respective long-term averages; which are calculated using an on-line FFT based filter. This type of filter guarantees a maximum measurement delay of 1-cycle. The results are the d and q components of the compensator current. The current orders to each phase are then calculated using an inverse d-q transform. Actual compensator currents corresponding to these orders are then produced using a hysteresis type Current-Reference Pulse Width Modulation (CRPWM) algorithm in EMTDC software using an on-line Fast Fourier Transform (FFT). In addition to the controls loops for flicker reduction, additional slower feedback control loop is present to ensure that the d.c. capacitor voltage is also controlled using additional real current order.

As before, the installation has a 40 Mvar of fixed third harmonic filter in addition to the STATCOM rating of $\pm XX$ Mvar. This allows a total compensation rating from $40 - XX$ Mvar (inductive) to $40 + XX$ Mvar (capacitive).

Typical current waveforms entering the a.c. network after application of such a compensator are shown in Figure 4.12. The high-frequency ripple due to the PWM switching action is hardly visible as the filter of fixed rating largely absorbs this. The uncompensated system currents i.e., the currents drawn by the arc furnace are also shown in Figure 4.12. and the effectiveness of the STATCOM in reducing the unbalance and harmonics in the system currents is apparent.

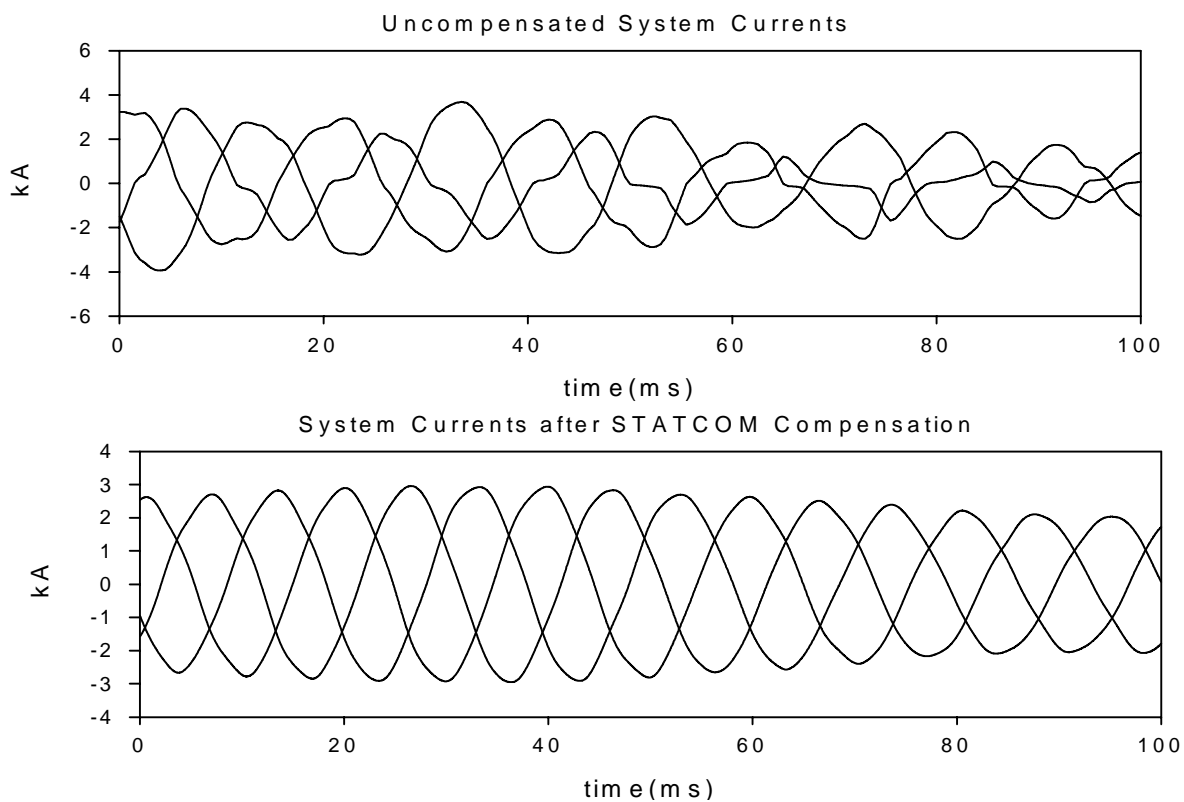
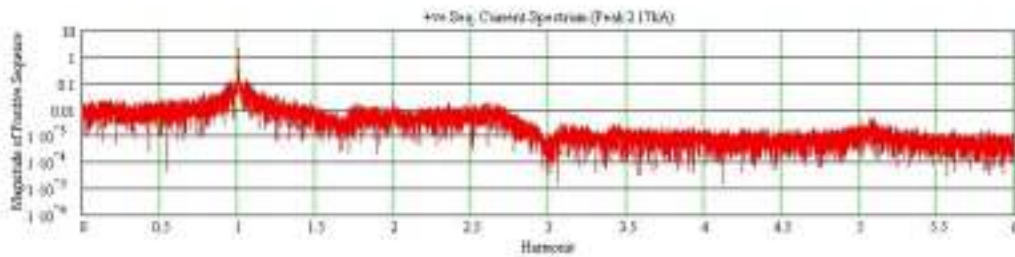
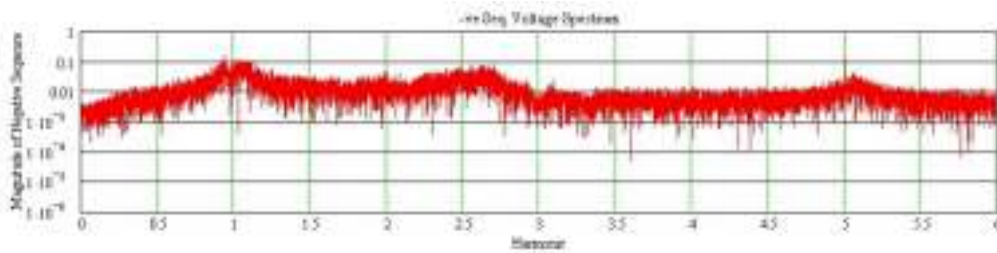

Figure 4.12. A.C. system currents with and without the STATCOM compensation.

Compensator behaviour can be analysed by examining the arc furnace current FFT spectrum as shown in Figure 4.13. The flicker causing current components are in the frequency bands at both sides of fundamental frequency. For 50 Hz this means the frequency bands from 30 to 49 Hz and from 51 to 70 Hz. The STATCOM compensation decreases both positive and negative sequence components at those frequencies drastically thus reducing the flicker as well. In this particular example there still are components at above mentioned frequency bands. In practice, it is possible that these components could be further reduced by optimising the STATCOM controls indicating that the STATCOM control used in the simulation example is not fully optimal.



a) Uncompensated positive sequence current



b) Uncompensated negative sequence current

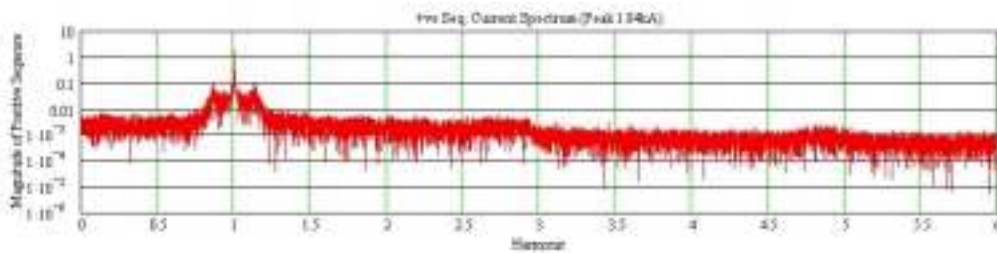

c) Compensated positive sequence current

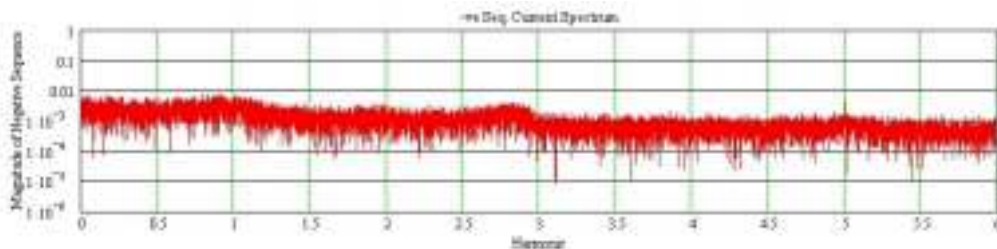

d) Compensated negative sequence current

Figure 4.13. Spectra of uncompensated arc furnace currents and currents with simulated realistic STATCOM compensator.(40 MVA and 40Mvar third harmonic filter) vertical scale is current in kA and horizontal scale is harmonic order as a multiple of the fundamental.

4.6 CONTROL PERFORMANCE CONSIDERATIONS

It has been already stated that the speed of response of the control system of the compensator is the most essential parameter in effective flicker reduction. In order to demonstrate the influence of speed the following calculation exercise was carried out. A specific delay was introduced to the instantaneous reactive power of arc furnace and subtracted from original signal. For this particular "compensated" reactive power the P_{st} was calculated for every minute. The results of the exercise illustrated in Figure 4.13 represent the performance of ideal STATCOM compensator with a certain control delay. From this figure it is clear that for

increasing values of the control system delay the flicker reduction performance will be adversely affected. In this respect an ideal STATCOM compensator was defined as a compensator which fully compensates the reactive component of the arc furnace current and the unbalance caused by that current removing all fluctuations in the $\pm 20\text{Hz}$ Hz bandwidth around the fundamental system frequency.

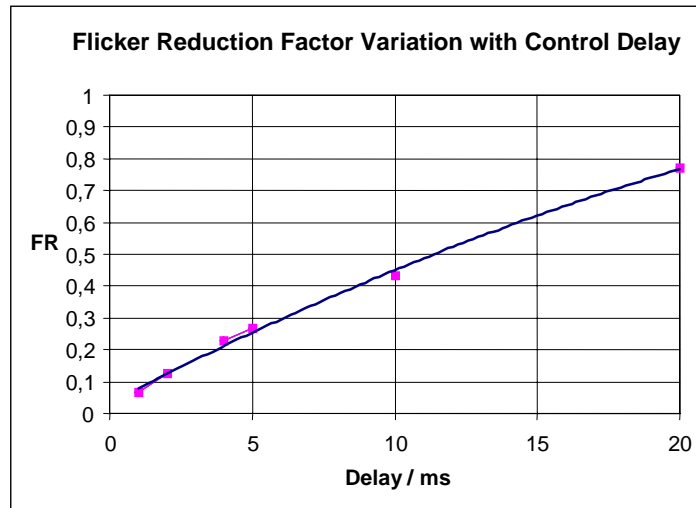

Figure 4.13. The effect of control delay to the Flicker Reduction Factor (FR).

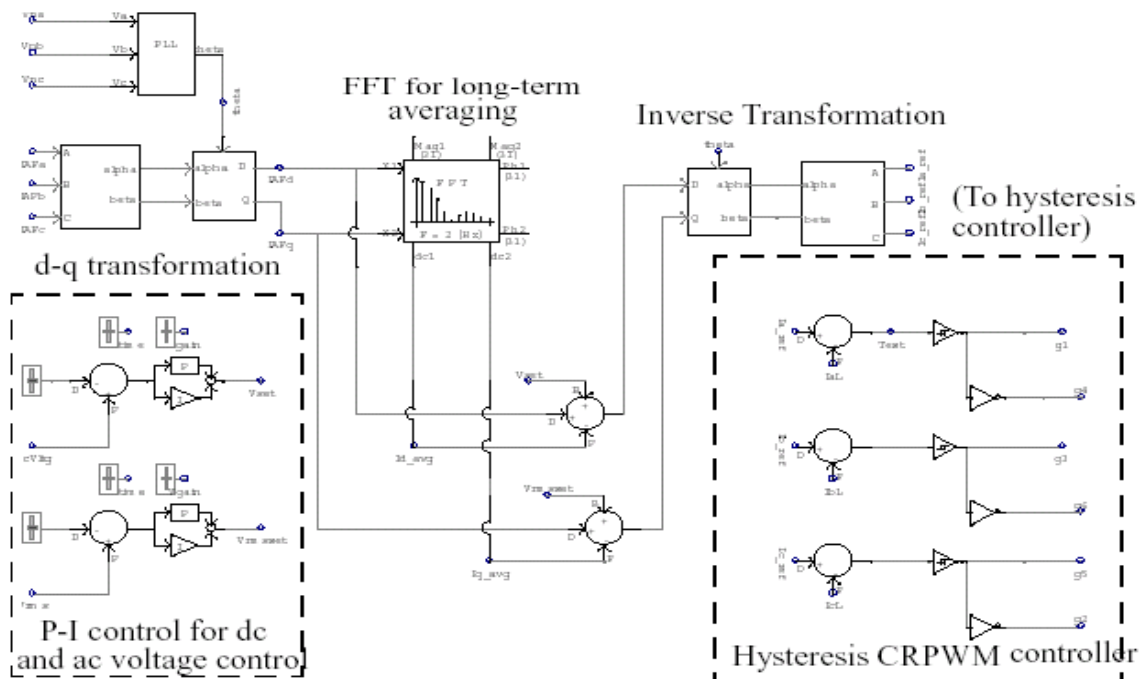

Figure 4.14. STATCOM controller used for the example EMTDC simulations.

In considering the response of the compensator associated with the arc furnace there are several other factors than the control delay which need to be taken into account. For example,

how the compensation can handle the low frequency waveform distortion and unsymmetry is a major concern as the distortion and unsymmetry is most severe during the melting period. The control method proposed in Chapter 3, and given in Figure 3.9 will compensate the low frequency waveform distortion and unsymmetry in full, and therefore achieves a much higher flicker reduction as shown in Figure 4.15. If however, the control method used only provides compensation for the fundamental frequency reactive power then the compensator performance obtained would be as that illustrated in Figure 4.16.

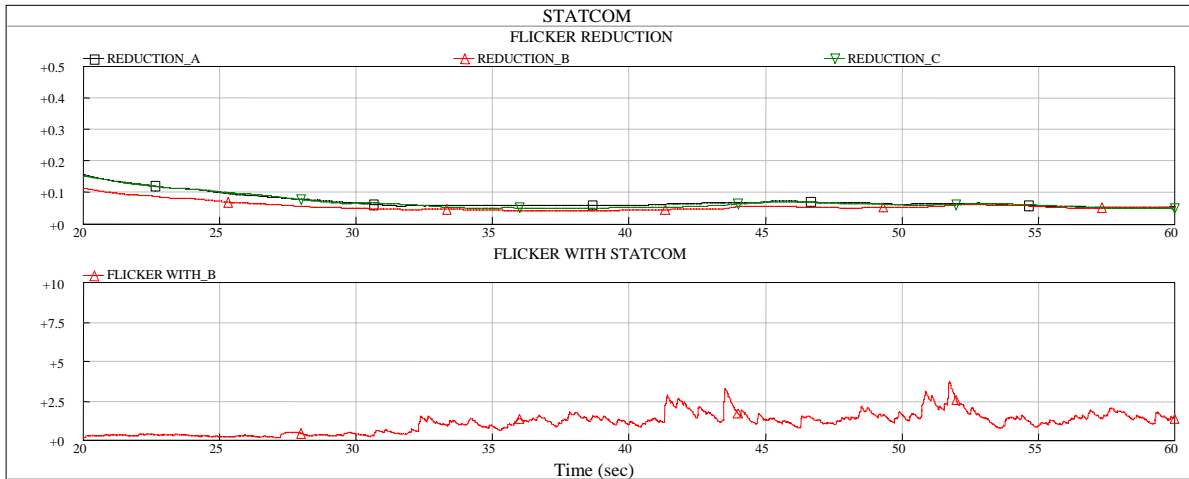

Figure 4.15. Simulated flicker reduction with proposed STATCOM control method of Figure 4.12 with the STATCOM control adjusted to compensate only the reactive power fluctuation including the low frequency distortion and unsymmetry. Top curve Flicker Reduction Factor of phases a, b and c and bottom curve instantaneous flicker magnitude at the arc furnace busbar.

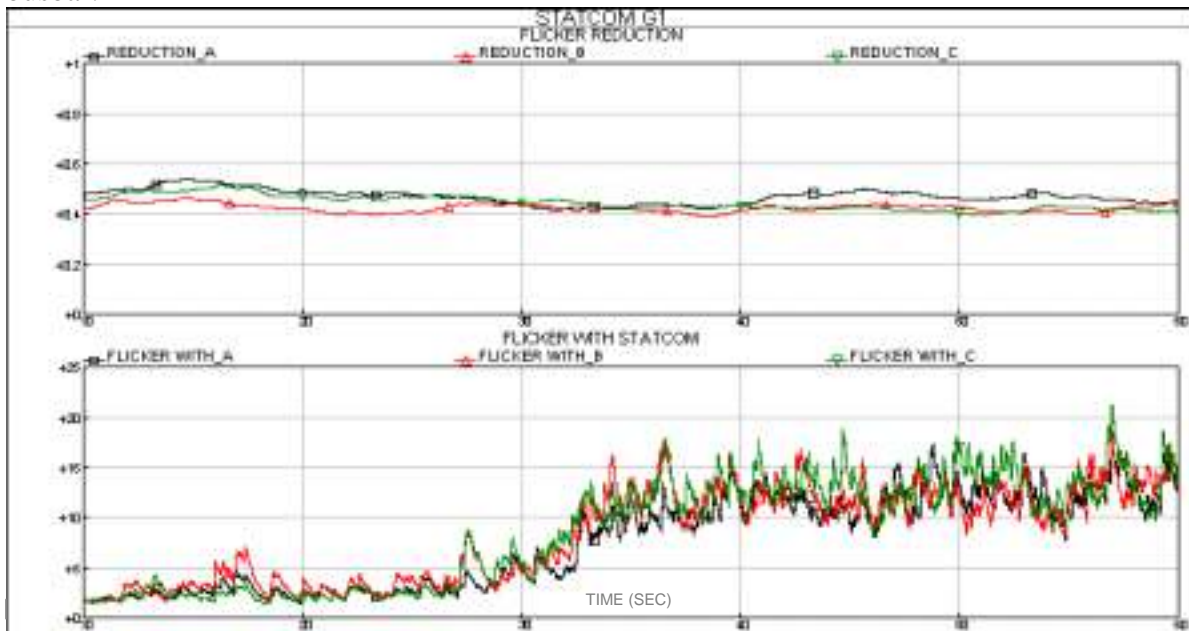

Figure 4.16. Simulated flicker reduction with STATCOM control scheme, which compensates only the fundamental frequency reactive power fluctuation, but not the low frequency distortion and unsymmetry. Top curve Flicker Reduction Factor of phases a, b and c and bottom curve instantaneous flicker magnitude at the arc furnace busbar.

4.7 RECOMMENDATIONS FOR COMPENSATOR RATING

The rating of STATCOM is not yet fully defined and therefore some remarks must be made. Rating of any device is usually related to ability to provide rated power continuously in certain defined working conditions e.g. ambient temperature, rated voltage, certain distortion and unbalance level of voltage. In addition for arc furnace compensation the capability to compensate unbalance is essential, because it sets requirements for d.c. capacitance. How this is taken into account in rating the STATCOM will be described below.

In reference [4-1] the following approximate equation for estimating the arc furnace SVC rating is suggested:

$$Q_{rated\ SVC} = [(FI-1) * S_{rated\ AF}] / (0.75)$$

with $FI < 2$ for SVC, and $S_{rated\ AF} = 0.6 * S_{ccf}$

where,

$Q_{rated\ SVC}$ = the rated reactive power of the SVC compensator at rated voltage

S_{ccf} = the fault level of arc furnace assuming infinite fault level of connection point

$S_{rated\ AF}$ = the rating of the arc furnace.

In a similar manner from observations of practical installations the following approximate equation for estimating the rating for an arc furnace STATCOM is suggested:

$$Q_{rated\ STATCOM} = 0.54 * \sqrt{(FI)} * S_{rated\ AF}$$

with $FI < 4$ to 6 for STATCOM, and $S_{rated\ AF} = 0.55$ to $0.65 * S_{ccf}$

where,

$Q_{rated\ STATCOM}$ = the rated reactive power of the STATCOM compensator at rated voltage

S_{ccf} = the fault level of arc furnace assuming infinite fault level of connection point

$S_{rated\ AF}$ = the rating of the arc furnace.

As an example, using these approximate equations for the stated parameters for the arc furnace and power system in Section 4.3 of this Chapter yields the following results:

For a target planning level to achieve a short term flicker severity $P_{st99\%} = 1$ requires a value of

$$FI = 4.7 \text{ or alternatively } FR = 0.213.$$

where,

FI = the Flicker Improvement Ratio of Compensator [$FI = P_{st\ without} / P_{st\ with} = 1 / FR$]

FR = the Flicker Reduction Factor of Compensator [$FR = P_{st\ with} / P_{st\ without} = 1 / FI$].

Using the above equations yields an SVC compensator rating:

$$S_{rated\ AF} = 0,6 * 120\ MVA = 72\ MVA$$

$$Q_{rated\ SVC} = [(4,7-1) * 72] / 0,75\ Mvar = 355\ Mvar$$

However, this approximate calculation gives a false impression since the SVC, however large its rating, can only provide a maximum flicker improvement ratio (FI) of 2 and therefore

cannot meet the required performance specification for this particular arc furnace installation at its specified point of connection.

In a similar manner using the above approximate equations yields a STATCOM rating:

$$S_{rated\ AF} = 0,6 * 120\ MVA = 72\ MVA$$

$$Q_{rated\ STATCOM} = 0,54 * \sqrt{(4,7)} * 72\ Mvar = 84\ Mvar$$

The estimate for the arc furnace rating given in the above approximate equations as 55 to 65 % of S_{cf} appears to be slightly low for this particular example. In fact from Figure 3.4 it is possible to calculate a value of 84 MVA which is 70% of S_{cf} .

Nevertheless the approximate equation yields 84 Mvar STATCOM rating (in practice ± 42 Mvar STATCOM with a 42 Mvar filter), which appears adequate for compensation as shown in Section 4.5. The simulation results presented in Section 4.3 indicate that there is no discernible benefit in increasing the STATCOM rating above the most probable power consumption of arc furnace. In practice, the occasional peaks of arc furnace power consumption exceeding the most probable furnace power consumption very rarely make a contribution to overall value of the flicker. As mentioned before it is very important for the utility to establish the most probable reactive power requirement to achieve the required performance. As Figure 4.2 illustrates that for this installation arc furnace operation at higher reactive power values than 84 Mvar is possible, but experienced rather more rarely in practice. In addition, it is also clear that for this arc furnace installation application of an SVC is not a viable compensation option as it cannot deliver the required flicker improvement performance even with a very large rating.

4.8 COMPARISON OF SVC AND STATCOM RATING

If, for the example installation, we want to compare ratings for STATCOM and SVC to achieve certain flicker performance then we must choose the FR achievable by the SVC, in this case FR = 0,5 or FI = 2.

Using the approximate equations in Section 3.6 yields an SVC compensator rating:

$$S_{rated\ AF} = 0,6 * 120\ MVA = 72\ MVA$$

$$Q_{rated\ SVC} = (2-1) * 72 / 0,75\ Mvar = 96\ Mvar$$

This in practice means 96 Mvar filter bank and 96 Mvar TCR rating for the SVC.

Using the approximate equations in Section 4.7 yields a STATCOM compensator rating:

$$S_{rated\ AF} = 0,6 * 120\ MVA = 72\ MVA$$

$$Q_{rated\ STATCOM} = 0,54 * \sqrt{(2,0)} * 72\ Mvar = 55\ Mvar$$

This reactive compensation installation might consist of a 35 Mvar filter bank and a STATCOM rated at ± 20 Mvar. However, this rating does not fulfil reactive power demand requirement illustrated in Figure 3.4. Obviously this can be solved by increasing the filter rating to 45 Mvar to achieve the required reactive power control range for most probable arc furnace operation of + 25 to + 65 Mvar as shown in Figure 3.2. If desired an additional reactive power of + 25 Mvar in the form of a thyristor switched capacitor or a filter can be included to cover the full range of possible arc furnace operation.

The STATCOM rating arrived at is in line with the calculated performance indicated in Table 4.1 and the result for SVC supports the experience in presented example in Section 4.5. This

difference in dynamic ratings, 96 Mvar for SVC and ± 20 Mvar for STATCOM is considerable and suggests that when considering compensator alternatives it is essential to define proper ratings for each combination.

4.9 REFERENCES

- [4-1] A.Robert and M. Couvreur “Arc Furnace Flicker Assessment and Prediction ” CIRED 1993 Conference, Paper 2.02.
- [4-2] UIE Guide on “Flicker Measurement and Evaluation, 1992.
- [4-3] D. Arlt and C. Eberlein “Network disturbances caused by ultra high power electric arc furnaces and possible reduction method”, 4th International Conference, Electrical Power Quality and Utilisation, September 23-25, 1997, Cracow, Poland.
- [4-4] L. Bisiach, I. Campestrini and C. Malaguti “Technical and Operational Experiences for Mitigating Interferences from High capacity Arc Furnaces”, CIGRE Session 1992, Paper 36-204.
- [4-5] E. De Jaeger “Measurement and Evaluation of the Flicker Emission Level from a Particular Fluctuating Load”, CIGRE/CIRED WG CC02 internal document, n. 9810.
- [4-6] M. Lahtinen, "New Method for Flicker Performance Evaluation of Arc Furnace Compensator", Paper 36-205, CIGRE Session 2002, Paris.

Chapter 5. APPLICATION OF STATCOM FOR ARC FURNACE COMPENSATION

Prepared by Arslan Erinmez

5.1 INTRODUCTION

This Chapter considers the application of a STATCOM for arc furnace compensation and flicker reduction and preparation of a functional specification for such applications. The Chapter examines both the direct application of STATCOM as well as application STATCOM alongside existing compensation especially with respect to existing arc furnace installations where extensions to the arc furnace installation, uprating or new arc furnace installations at the same location are planned. Following the definition of technical requirements and subsequent studies confirming broad characteristics of the STATCOM by the utility, a functional specification, enabling the utility to invite tenders from manufacturers for the equipment is required. This chapter presents the information that generally needs to be included in such a functional specification to ensure adequate information exchange between the utility and suppliers.

5.2 CONSIDERATIONS IN APPLICATION OF STATCOM FOR ARC FURNACE COMPENSATION

Arc furnace compensation methods applied to date were summarised in Section 1.6 of Chapter 1. These methods included, application of various types of power factor correction equipment arranged in a harmonic filter configuration and SVCs. The power factor correction equipment consisting of shunt connected capacitors are usually arranged in the form of harmonic filters to additionally limit the level of harmonics generated by the arc furnace. In Chapter 1 the advantages and disadvantages of various types of arc furnace compensation applied to date were also described together with the reasons for application of STATCOM.

In the following paragraphs the main arc furnace compensation performance considerations, referred to in detail elsewhere in this document, are summarised to assist with the functional specification of STATCOM and hybrid compensation applications.

Elements of a typical SVC arc furnace compensation application are shown in Figure 5.1. The SVC for such an application consists of Thyristor Controlled Reactor (TCR) formed by a thyristor valve connected in series with an inductor. A set of harmonic filters including additional inductor and capacitor elements are connected in parallel with the TCR to form the SVC installation. The current through the TCR can be varied by adjusting the point on the a.c. voltage waveform at which the thyristors in the are turned on and this current determines the reactive power in the inductor. The TCR absorbs reactive power while the harmonic filters, which are essentially capacitive, generate reactive power. Generally, the output of the SVC is controlled by an automatic controller, which adjusts the firing angle of the thyristors based on the voltage at the point of common coupling of the arc furnace and SVC to the power system. The TCR itself generates harmonics and the capacitor banks need to be arranged as harmonic filters to limit the harmonics generated by the arc furnace and the TCR.

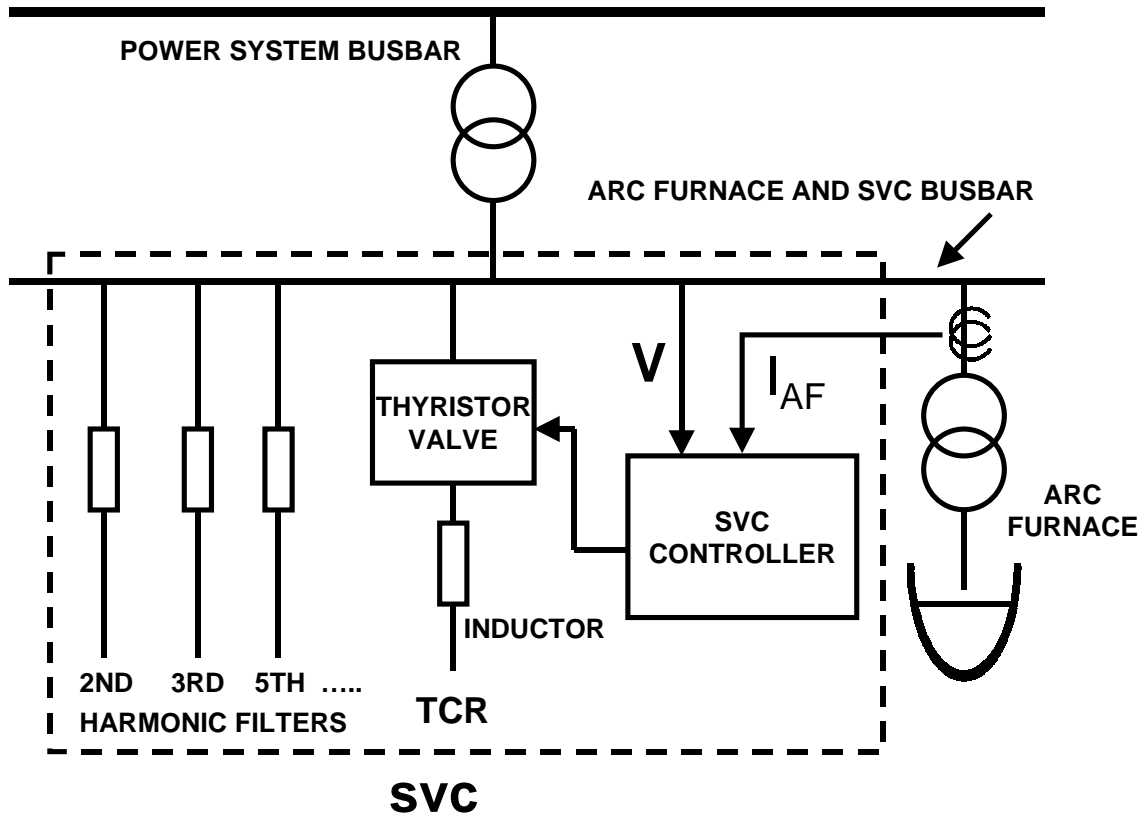

Figure 5.1 Elements of a typical SVC application for arc furnace compensation.

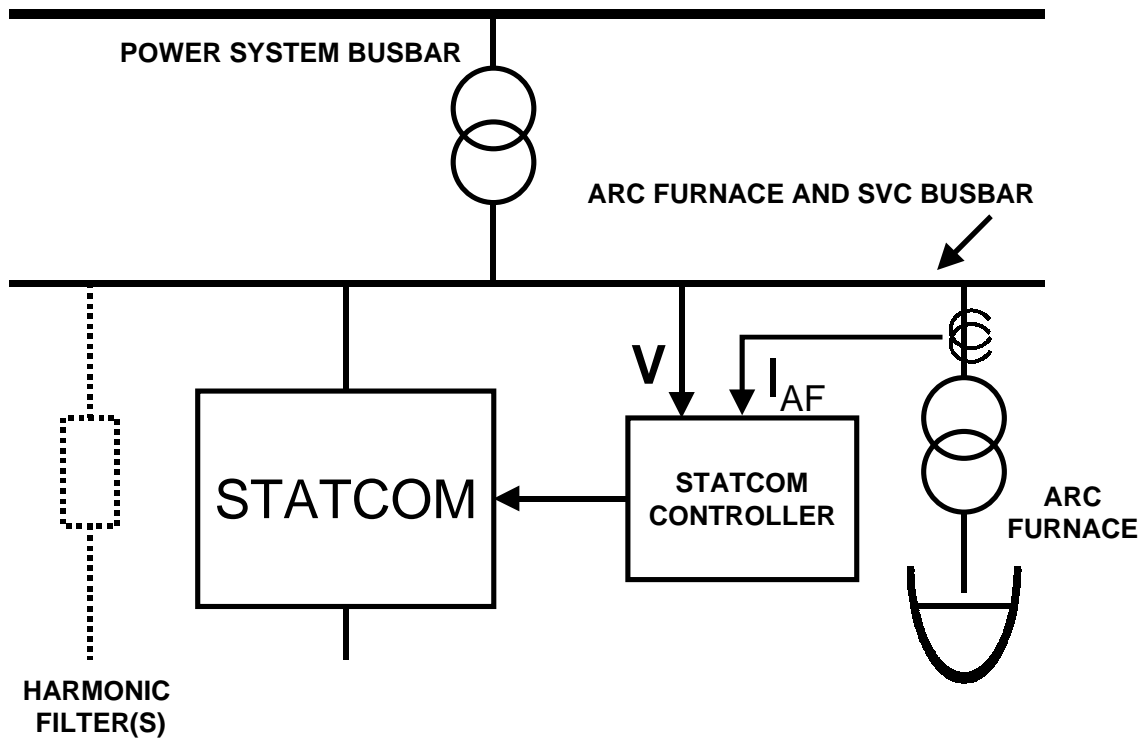

Figure 5.2 Elements of a typical STATCOM application for arc furnace compensation.

As described in Chapter 4 an approximate estimation of the SVC rating for arc furnace compensation applications could be found by using the relation given in reference [5-1]:

$$Q_{rated\ SVC} = [(FI-1) * S_{rated\ AF}] / (0.75)$$

with $FI < 2$ for SVC, and $S_{rated\ AF} = 0.6 * S_{ccf}$

$$FI = P_{st\ without} / P_{st\ with} = 1 / FR$$

where,

- $Q_{rated\ SVC}$ = the rated reactive power of the SVC compensator at rated voltage;
- S_{ccf} = the fault level of arc furnace assuming infinite fault level of connection point;
- $S_{rated\ AF}$ = the rating of the arc furnace;
- FI = the Flicker Improvement Ratio; and
- FR = the Flicker Reduction Ratio.

For example, to compensate an arc furnace of 100MVA rating and to achieve a flicker improvement ratio (FI) of 2, this approximate equation yields the SVC (TCR) rating of approximately 135Mvar. In applying this formula it must be borne in mind that the formula is only an approximation and the maximum value of the flicker reduction factor for a normally rated SVC is in the range of 2. In addition, in deciding the rating and performance specifications of an arc furnace compensator appropriate studies need to be carried out by the utility.

The SVC is essentially a controlled impedance, which continually varies in accordance with the operational requirements of the arc furnace. Careful attention to the design of the filters associated with the SVC is therefore required to avoid parallel resonances between the filters and the power system.

Elements of a typical STATCOM for arc furnace compensation applications is shown in Figure 5.2. In a similar manner applying the approximate equation suggested for estimating the rating for an arc furnace STATCOM in Section 4.7 of Chapter 4:

$$Q_{rated\ STATCOM} = 0.54 * \sqrt{(FI) * S_{rated\ AF}}$$

with $FI < 4$ to 6 for STATCOM, and $S_{rated\ AF} = 0.55$ to $0.65 * S_{ccf}$

$$FI = P_{st\ without} / P_{st\ with} = 1 / FR$$

where,

- $Q_{rated\ STATCOM}$ = the rated reactive power of the STATCOM compensator at rated voltage;
- S_{ccf} = the fault level of arc furnace assuming infinite fault level of connection point;
- $S_{rated\ AF}$ = the rating of the arc furnace;
- FI = the Flicker Improvement Ratio; and
- FR = the Flicker Reduction Ratio.

As an example, to compensate an arc furnace of 45MVA to achieve a flicker reduction factor of 4, the approximate rating of the STATCOM is calculated to be around 49Mvar. In practice, this means that a ± 24.5 Mvar STATCOM which can be utilised together with a 24.5Mvar filter.

For an arc furnace of 100MVA, to achieve the same compensation performance as the SVC above, i.e., to achieve a flicker improvement ratio of 2 with a STATCOM, the approximate rating of the STATCOM would be approximately 78Mvar. In practice, this would mean a compensator installation consisting of a ± 39 Mvar STATCOM and a 39Mvar filter.

STATCOM is essentially a controlled voltage source connected to the network through an impedance. As STATCOM applications for flicker mitigation generally utilise current control techniques, it could also be considered as equivalent to a controlled current source. Operation of STATCOM is therefore independent of the power system parameters.

The STATCOM is able to both generate and absorb reactive power and therefore does not essentially require capacitor arrangements for additional reactive power generation. In addition STATCOM only generates relatively low magnitudes of higher order harmonics which generally need less filtering due to inherently better damping of these harmonics by the power system. In practice, however, for economical reasons and for harmonic mitigation purposes some harmonic filters are included in arc furnace compensation applications.

At existing arc furnace installations where extensions to the arc furnace installation and/or furnace uprating is considered or in some cases for new arc furnace installations use of hybrid compensation techniques may be considered. This approach may take the form of utilising the existing SVC together with a STATCOM as shown in Figure 5.3.

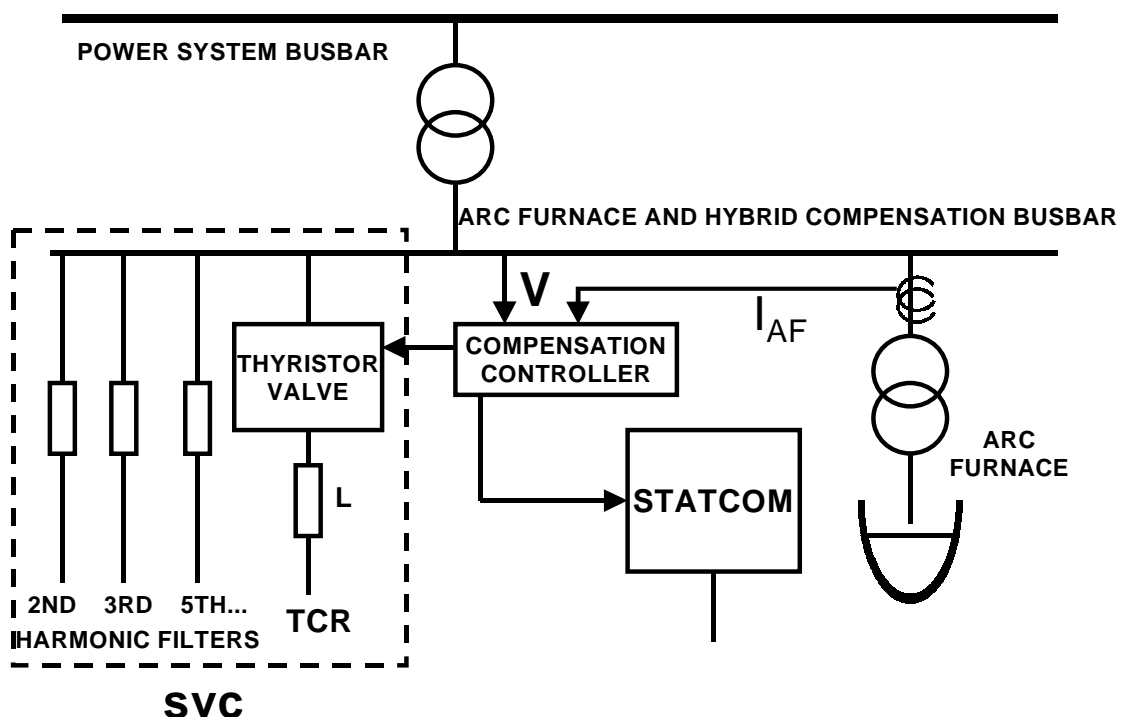

Figure 5.3 Elements of a typical hybrid arc furnace compensation application.

This type of application could offer cost reductions but require the installation of a controller co-ordinating the actions of both the STATCOM and the SVC. This control co-ordination could be in the form of utilising the SVC to compensate for relatively the slower fluctuations of the arc furnace current and the STATCOM to compensate the rapid fluctuations.

In such a hybrid application the equipment designer has many choices in terms of the rating, control duty and parameters of the STATCOM, the SVC and the filters. In terms of the choice of the duty it is considered optimal for the designer to assign the duties of various components forming the hybrid compensator as follows.

- The STATCOM as a voltage source will present a more balanced set of three phase voltages to the arc furnace and due to its superior speed of response will act as an active filter to reduce the harmonics generated by the arc furnace and the TCR.
- In addition, the STATCOM will effectively damp parallel resonances with the power system especially at harmonic frequencies. In some cases it may eliminate the need for the installation of second and third harmonic filters.
- The passive harmonic filters associated with the SVC will absorb the harmonic currents generated by the arc furnace and the TCR.
- The presence of STATCOM will increase the operational efficiency and speed of response of the TCR enabling the hybrid compensator to perform in a superior manner to a compensator consisting solely of an SVC.
- The SVC will compensate the relatively slower variations of the arc furnace current.

5.3 FUNCTIONAL SPECIFICATION OF STATCOM FOR ARC FURNACE AND DISTURBING LOAD COMPENSATION APPLICATIONS

In specifying the arc furnace flicker reduction and disturbing load compensation requirements, there are likely to be several areas of compensation performance where the utility can specify a minimum requirement, but would wish to recognise a deliverable device performance capability above the minimum requirement. A method by which such recognition may be indicated is through a premium for those areas in which performance above the minimum requirement is desirable.

In the following sections the information which needs to be respectively provided by the utility and compensation equipment manufacturer is summarised. However, it is recognised that for a successful installation the participation of two other parties is essential namely, the owner/ operator and the manufacturer of the arc furnace/disturbing load plant. The information exchange requirements can be classified as follows:

- general requirements describing the intended application of the STATCOM;
- power system characteristics giving details of the power system to which the STATCOM will be connected;
- the characteristics of the disturbing load, i.e., arc furnace, woodchip mill etc, giving details of the load the STATCOM will be compensating;
- steady-state performance requirements;
- dynamic performance requirements including control and monitoring facilities;

- performance tests and acceptance requirements;
- site and environmental considerations; and
- other considerations relating to health and safety and other ancillary requirements.

In order to enable the manufacturer(s) to offer the most suitable and economic equipment design a clear description of the broad performance requirements of the particular application together with a detailed description of the power system technical and operational characteristics. This is essential together with a good dialogue with the manufacturer both at the tender stage and subsequent to the issue of contract.

5.4 UTILITY, PLANT OWNER AND COMPENSATOR MANUFACTURER INFORMATION REQUIREMENTS

5.4.1 General Requirements

Utility Specification Requirement	Manufacturer/Owner Supplied Information
Broad statement of compensation requirement including details of the permissible operational envelope, e.g., <ul style="list-style-type: none"> - Flicker performance improvement required - Operating power factor improvement required - Limits of acceptable flicker - Limits of acceptable repetitive voltage variations - Limits of acceptable voltage unbalance - Limits of negative sequence voltages and/or currents - Limits for harmonic emission and electromagnetic interference 	Calculated installation performance characteristics.
Nominal connection voltage and details of connection requirements at the proposed point of connection. Indication of design preferences if a combination of devices is intended.	Diagrams showing all major components and their method of connection to the system. List of equipment, materials and services provided and specific exclusions. Component data including tolerances.
Minimum and continuous performance envelopes. In particular, at the minimum and maximum connection point voltages at which particular compensation performance should be achieved.	Device performance envelope, with specific confirmation of the performance at key points of the envelope.
If the installation is intended to be upgraded/uprated or operated in a different manner at a future date, likely magnitude of upgrading.	Details of proposals for upgrading.

5.4.2 Power System Characteristics

Utility Specification Requirement	Manufacturer/Owner Supplied Information
Range of System Voltages at the point of connection	Confirmation of operation
Range of System frequency and rate of frequency change	Confirmation of design and operation
Maximum and minimum fault levels at the point of connection	Confirmation of operation
Maximum fault clearance times	Confirmation of operation
Maximum harmonic voltage and current distortion at the point of connection. Harmonic impedance envelopes at the point of connection.	Confirmation of operation
Maximum phase imbalance at the point of connection	Confirmation of operation
Acceptable limits for flicker at the point of common coupling to other consumers	Confirmation of operation

5.4.3 Steady-state Performance

Utility Specification Requirement	Manufacturer/Owner Supplied Information
Range of system conditions over which rated performance is required (i.e. frequency, unbalance, harmonics, impedance, fault level, flicker)	Confirmation of performance over the range of operating conditions.
Range of system conditions over which the device is to remain operational or connected (i.e., voltage, frequency, unbalance, harmonics, system impedance, fault level)	Confirmation that the device remains operational or connected and description of the expected performance.
Maximum harmonic emissions (voltage and current) for a range of system impedances at the point of connection	Harmonics generated (voltage and current) , filters and filter design criteria.
Immunity to power system harmonic levels and switching transients	Confirmation of device immunity
Maximum negative and zero phase sequence emissions (voltage and current), as compared with a balanced source, for a range of system impedances at the point of connection.	Levels of negative and zero phase sequence emissions.
System frequency range & rate of frequency change.	System frequency range capability.
Limits of permissible operation beyond the 95% probability level	Confirmation of operation.

5.4.4 Dynamic Performance, Control and Monitoring Facilities

Utility Specification Requirement	Manufacturer Supplied Information
Dynamic behaviour of the compensation device and the overall arc furnace/disturbing load in relation to or influencing the dynamic performance of the power system.	Confirmation of dynamic performance characteristics of the compensator and the overall arc furnace/disturbing load over a range of system fault levels. Device models for dynamic studies.
Ability to ride through system faults and other low voltage conditions.	Performance in the presence of faults and other low voltage conditions. Control and protection provisions for operation in the presence of faults and other low voltage conditions.
Short-term device ratings and minimum requirements.	Short-term device ratings.
Control law requirements. Control law ranges. Measurement methods and requirements.	Device control modes and control laws, including details of control signals and their measurement method. Facilities for the provision of power-swing damping control.
Remote and local control, alarm and monitoring requirements for power system operational purposes. Data interface requirements.	Remote and local man-machine interfaces, detailing control, alarm, communication and monitoring facilities Adjustable parameters and their method of adjustment.
Requirements to operate under failure of one or more components. Permitted time of operation outside permissible limits.	Depleted operating mode facilities including control laws. Transient and persistent effect of component failure.
Transient and temporary overvoltages, shape, magnitude and duration. System insulation levels.	Overvoltage withstand capability, overload performance and protection. Insulation co-ordination design
Protection standards.	Protection system, including protection against internal failures. Worst case internal fault in terms of duration and effect on compensating current.
Initial energisation and shut-down requirements. Auxiliary power and cooling facilities available.	Auxiliary power facilities required system descriptions Method of initial energising, re-start and shut-down.

5.4.5 Performance Tests

Utility Specification Requirement	Manufacturer Supplied Information
Test requirements to establish the performance of the installation - Tests on the connection point equipment - Test specification and schedule - Measurement protocols and standards - Performance acceptance criteria - Establishing compliance of installation with utility statutory requirements and obligations.	Type test evidence. Test simulation data. Test schedules. Type of test equipment to be used to verify performance. Compliance report.

5.4.6 Site and Environmental

Utility Specification Requirement	Manufacturer Supplied Information
Space and footprint restrictions. Site access and transport limitations. Initial site and single-line diagram of Users connection point. Ownership boundaries.	Device layout and layout options. Access and transport requirements.
Electric and magnetic field limitations Electromagnetic immunity requirements.	Electromagnetic Field Generation. Electromagnetic immunity levels.
System grounding (earthing) conditions.	Type of grounding (earthing) and grounding (earthing) requirements
Ferroresonance standards.	Ferroresonance characteristics.
Transformer inrush current considerations.	Inrush current mitigation measures.
Ambient temperature, pressure and humidity ranges	Ambient temperature, pressure and humidity capabilities.
Solar, snow and ice, wind, air pollution, isokeraunic and seismic conditions.	Confirm operation under required conditions.
Noise restrictions, acoustic and electromagnetic and telephone interference restrictions.	Noise level, radio interference level, and screening requirements.

5.4.7 Other Considerations

Utility Specification Requirement	Manufacturer/Owner Supplied Information
Operational performance evaluation criteria. Restrictions to operation under specific power system conditions. Restrictions to operation in cases of performance shortfall.	Compliance with the agreed criteria.
Responsibility schedules at sites with both utility and customer equipment	Agreed responsibility schedules and compliance.
Special premiums applied to performance above the minimum level specified.	Capability of the installation or compensation equipment above the specified minimum.
Health & Safety requirements.	Health & Safety Standards
Fire safety requirements.	Use of fire retardant materials
Training requirements.	Utility and arc furnace operator training provisions.
Connection testing and project completion schedule.	Project timescales.

5.5 EQUIPMENT DESIGN STANDARDS

At present there is no single national or international standard which specifically deals with converter equipment using semiconductor power electronic components such as gate turn-off thyristors (GTOs) and insulated gate bipolar transistors (IGBTs). However, IEEE Std 1031-1991 (IEEE Guide for a Detailed Functional Specification of Static VAR Compensators) provides general guidance on SVCs.

The following IEC and other standards are relevant to major components of STATCOM.

IEC 70	Power capacitors
IEC 71-2	Insulation co-ordination: Application Guide
IEC 76	Power transformers
IEC 99-4	Metal-oxide surge arresters without gaps for a.c. systems
IEC 129	AC disconnectors (isolators) and earthing switches of rated voltage above 1kV
IEC 146	Semiconductor converters
IEC 147	Essential ratings and characteristics of semiconductor devices and general principles of measuring methods
IEC 168	Tests on indoor and outdoor post insulators of ceramic material or glass for systems with nominal voltages greater than 1kV
IEC 185	Current transformers
IEC 186	Voltage transformers
IEC 265	High-voltage switches

IEC 273	Dimension of indoor and outdoor post insulators and post insulator units for systems with nominal voltages greater than 1kV
IEC 517	Gas insulated metal enclosed switchgear for rated voltages of 72.5kV and above
IEC 694	Common clauses for high voltage switchgear and control gear standards
IEC 700	Testing of semiconductor valves for high voltage d.c. power transmission
IEC 801	Electromagnetic compatibility for industrial process measurement and control equipment
IEC 815	Guide for selection of insulators in respect of polluted conditions
IEC 870	Telecontrol equipment and systems
IEC 871-1	Shunt capacitors for a.c. power systems having a rated voltage above 660V
IEC 947-3	Low voltage switchgear and controlgear
IEC 1071-1	Power electronic capacitors

5.6 REFERENCES

- [5-1] A. Robert, and M. Couvreur “Arc Furnace Flicker Assessment and Prediction” Paper 2.02, CIRED 1993 Conference.

Chapter 6 EXAMPLES OF STATCOM APPLICATIONS FOR ARC FURNACE AND FLICKER CONTROL

Prepared by Laszlo Gyugyi, Tomas Gustafsson, Shoichi Irokawa and Arslan Erinmez

6.1 INTRODUCTION

In this Chapter an overview of existing and currently proposed STATCOM applications for arc furnace and flicker control is presented. The particulars of and design operational data for each specific application is summarised in Table 6.1. This table also includes information on the control features, harmonic performance characteristics and field tests performed on the installations. The experience gained from these installations indicated that confidence gained in the techniques developed and reliable operation achieved would result in further applications.

In the following sections of this Chapter other salient features, design characteristics and operational experience details of selected applications in service will be discussed together with details of the STATCOM converter and control configuration.

6.2 SEGUIN, TEXAS, USA

Siemens (formerly Westinghouse) announced the application of STATCOM for arc furnace compensation in 1995 [6-1], and has subsequently installed a large STATCOM-based compensator for Structural Metals Inc. (SMI) of Seguin, Texas. This arc furnace plant has a 100-ton furnace with a nominal rating of 80 MVA. A 138 kV transmission line from the Guadalupe Valley Electric Co. provides the main power supply, with a step-down transformer feeding the furnace transformer at approximately 15 kV. Flicker has long been a problem at this location and SMI has frequently been required to curtail production to stay within acceptable flicker limits. For many years a conventional SVC was used for power factor correction and this provided some measure of flicker mitigation. When the SVC was accidentally destroyed, SMI took the decision to replace it with STATCOM technology, which offered to provide a proper solution for the flicker problem.

The SMI installation, commissioned during 1998, comprises a ± 80 MVA STATCOM with a shunt coupling transformer connecting it to the 15 kV furnace bus. The STATCOM operates in conjunction with a fixed 60 MVA a.c. capacitor bank also connected in shunt with the 15 kV bus, as shown in Figure 6.1. Details of the installation are illustrated in the two pictures in Figure 6.2 showing details of the fixed capacitor, the STATCOM transformer, the d.c. capacitor and the STATCOM valves. The STATCOM rating is chosen such that, together with the capacitor, it can supply all of the sustained reactive power requirements of the arc furnace. In addition, the STATCOM has sufficient current rating to supply the randomly fluctuating instantaneous real (high frequency) and reactive power components drawn by the furnace. The STATCOM also inherently supplies those components of current (including negative sequence fundamental) associated with unbalanced operation of the furnace. As a result, all of these components of furnace current are eliminated from the main power feeder, reducing voltage flicker on the high voltage flicker bus.

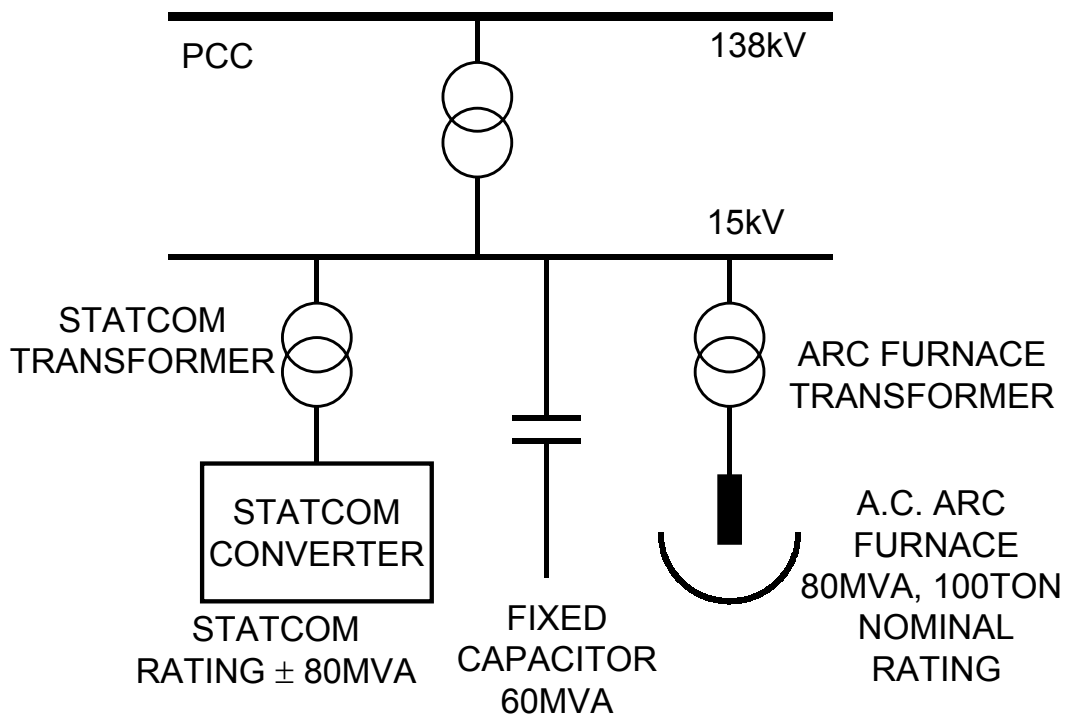

Figure 6.1 Single line diagram of the installation at Seguin, USA.

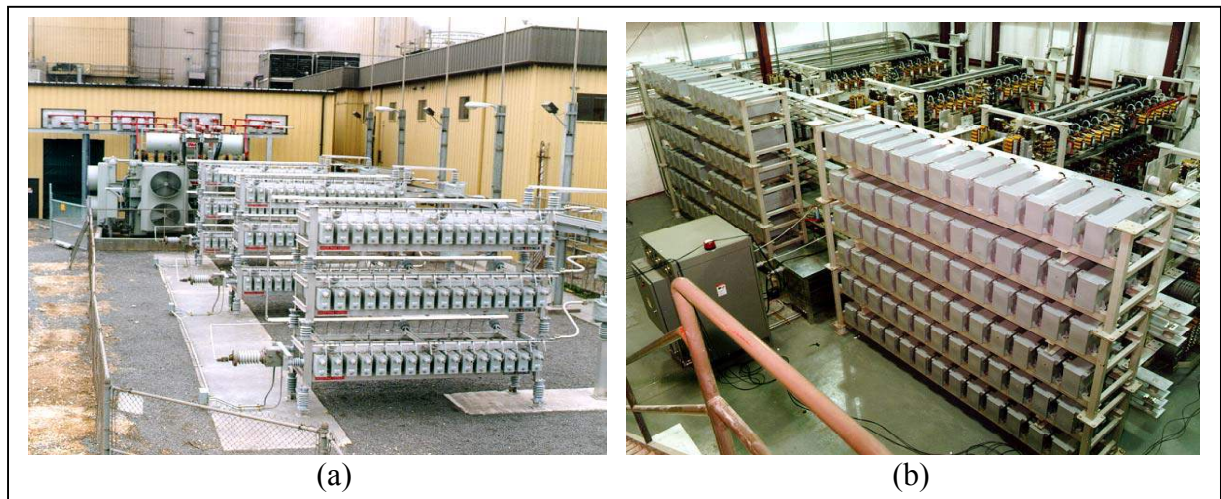

Figure 6.2. View of Seguin installation showing the fixed capacitor bank and STATCOM coupling transformer in picture (a) and the STATCOM valve hall and d.c. bus capacitors in picture (b).

In essence, the STATCOM control system acts to make the inverter operate as a controlled current source, delivering the desired current components to the arc furnace busbar on command. A further objective of the control is to regulate the voltage on the d.c. capacitor bank connected to the d.c. terminals of the STATCOM converter.

The operation of the inverter is governed by a high bandwidth vector current control loop that separately controls the real and reactive current output. All control computations are performed in a rotating reference frame that is maintained synchronous with the a.c. busbar voltage. The references to the current controller are obtained by combination of the measured furnace currents and error signals calculated for the STATCOM d.c. busbar voltage and the furnace bus voltage. In the course of normal operation, the main power feeder supplies the low frequency components of furnace real power, and the appropriate level of reactive power consistent with maintaining the desired level of voltage on the arc furnace busbar.

The flicker reduction performance of this installation is illustrated in the recordings in Figure 6.3 (where the left hand scale represents the flicker level and the right hand scale furnace power in MW) [6-1] and in Figures 2.29 and 2.30 included in Chapter 2. The figures clearly illustrate that with the STATCOM in operation a flicker reduction factor of at least 4 times is easily achieved for this particular installation. In this case based upon the long established experience of the utility and the customer the performance of the STATCOM and the arc furnace installation was evaluated using the so-called “Schwabe Flicker Meter” extensively utilised in the USA. The flicker measurements were carried out at the 138 kV flicker bus, and the flicker level recorded and shown in Figures 2.29 and 2.30 was the voltage variation in percent (according to the measurement definition given for the Schwabe meter) with respect to the r.m.s. bus voltage. A description of the “Schwabe Flicker Meter” is given in Appendix C.

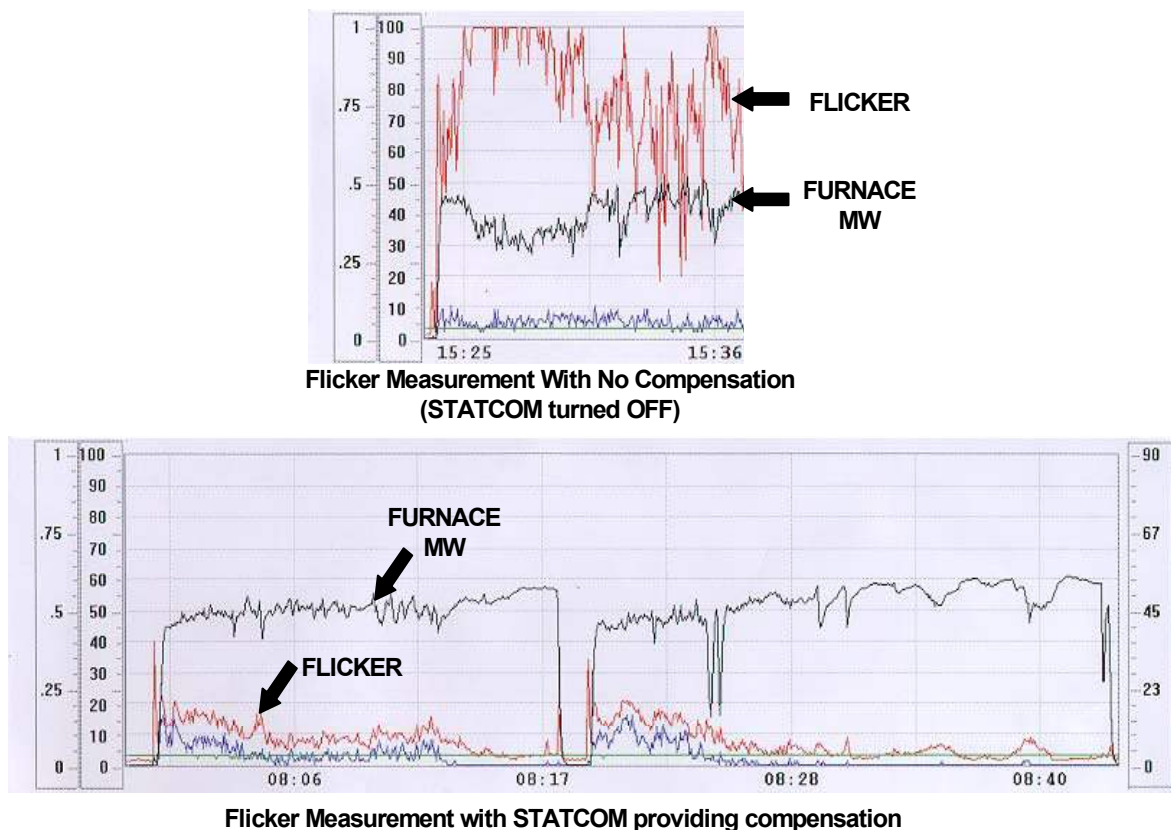

Figure 6.3. Flicker measurements from SMI arc furnace, Seguin, USA. Top recording shows the extent of the flicker when STATCOM is not running. Lower recording shows the flicker reduction when STATCOM is operating. The left hand scale represents the flicker level and the right hand scale furnace power in MW.

6.3 HAGFORS, SWEDEN

This is a ± 22 Mvar STATCOM (trade marked SVC Light[®] by the manufacturer ABB) installation in operation since 1999 which together with the existing harmonic filters at the site yields an overall reactive compensation range of 0-44 Mvar (capacitive). The installation owned by the steel producer Uddeholm Tooling AB, consists of an a.c. electric arc furnace (EAF) rated at 31,5 MVA with a 20% temporary overload capability for melting scrap metal, and a Ladle Furnace (LF) for subsequent refining rated at 6 MVA plus a 30% overload capability. Both furnaces are fed from a 132 kV grid via an intermediate voltage of 10,5 kV as shown in Figure 6.4. All SVC Light[®] equipment except the phase reactors and the harmonic filters is housed indoors in a small pre-fabricated building. The phase reactors and filters have been erected in a small, fenced outdoor yard. All in all, this gives a very compact layout for the installation as shown in Figure 6.5.

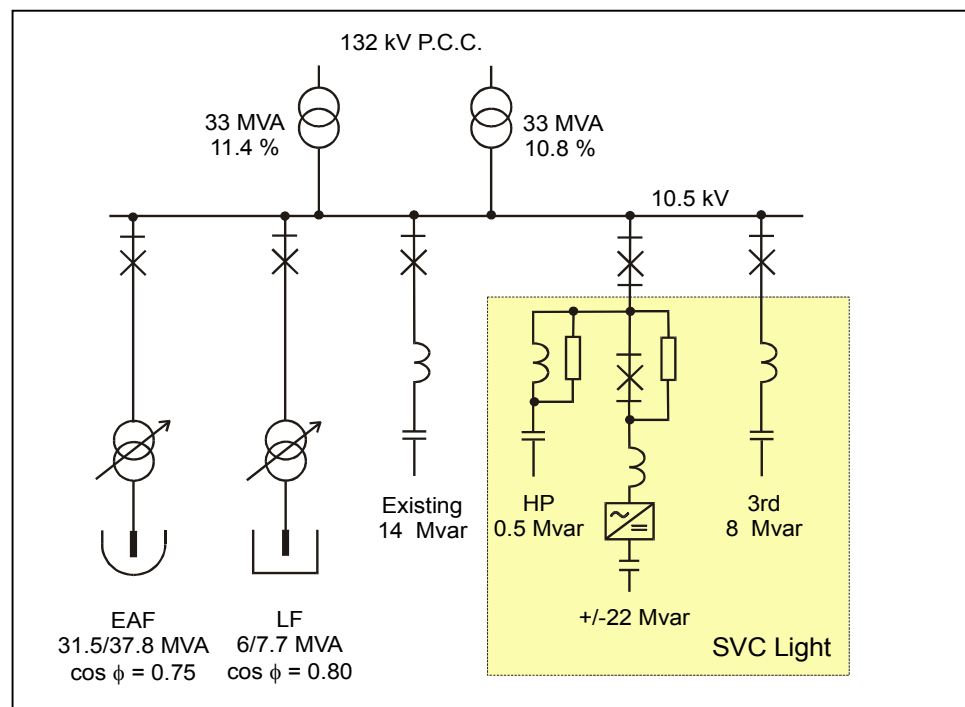

Figure 6.4 Single-line diagram of STATCOM (trade marked SVC Light) at Hagfors, Sweden.

The power grid system feeding the arc furnace installation is relatively weak, with a fault level at the Point of Common Coupling which normally does not exceed 1000 MVA. This fault level is not sufficient to enable operation of the both arc furnaces while maintaining reasonable power quality at the point of common coupling with other electricity consumers. Prior to the installation of the STATCOM, the Hagfors steel mill was a source of power quality problems to the utility, disturbing both the neighbouring consumers as well as affecting the operation of the steel mill itself. The flicker performance target of $P_{st95\%} \# 1$ set by the utility was met with the additional benefit of better furnace performance with regard to increased available melting power and a decrease in electrode consumption.

The voltage sourced converter (VSC) of a three-level design utilises Integrated Gate Bipolar Transistors (IGBTs) as switching devices. The converter also uses Pulse-Width Modulation (PWM), with a switching frequency of 1.65 kHz to generate a smooth balanced sinusoidal voltage.

The fast response of the STATCOM enables its use as an active filter in this application. The measured flicker with and without the STATCOM is illustrated in Figure 6.6. The measured long term flicker reduction ratio for the installation was around 3.5, which met the target set for $P_{st95\%}$ # 1 could be met.



Figure 6.5 View of Hagfors installation showing the SVC Light equipment and the phase reactors.

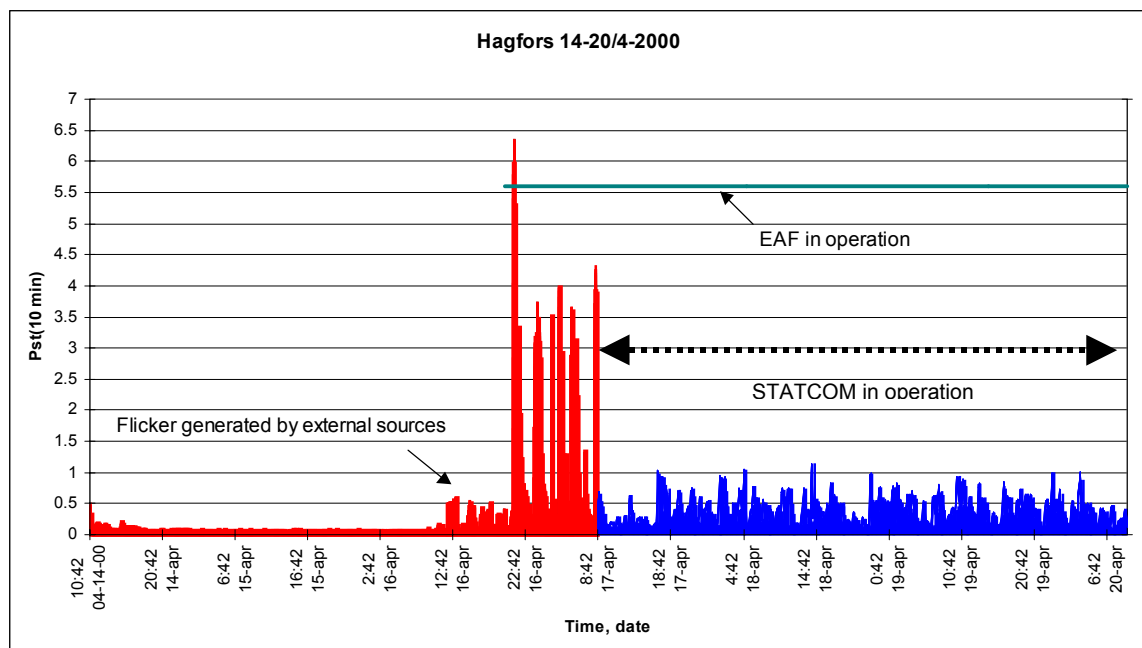

Figure 6.6 Flicker levels without and with STATCOM in operation at Hagfors.

The STATCOM uses an open-loop type control system for flicker reduction and for optimum speed of response. As an additional feature, the control system includes a second, but slower control function for power factor control. This feature permits a high and stable power factor of the plant at all times, with the power factor target of p.f. 0.95.

Measurements of the active power consumption of the arc furnace plant without and with the dynamic STATCOM compensation indicated that the voltage at the furnace busbar is better stabilised with the STATCOM in operation and this increases the available furnace power as shown in Figure 6.7.

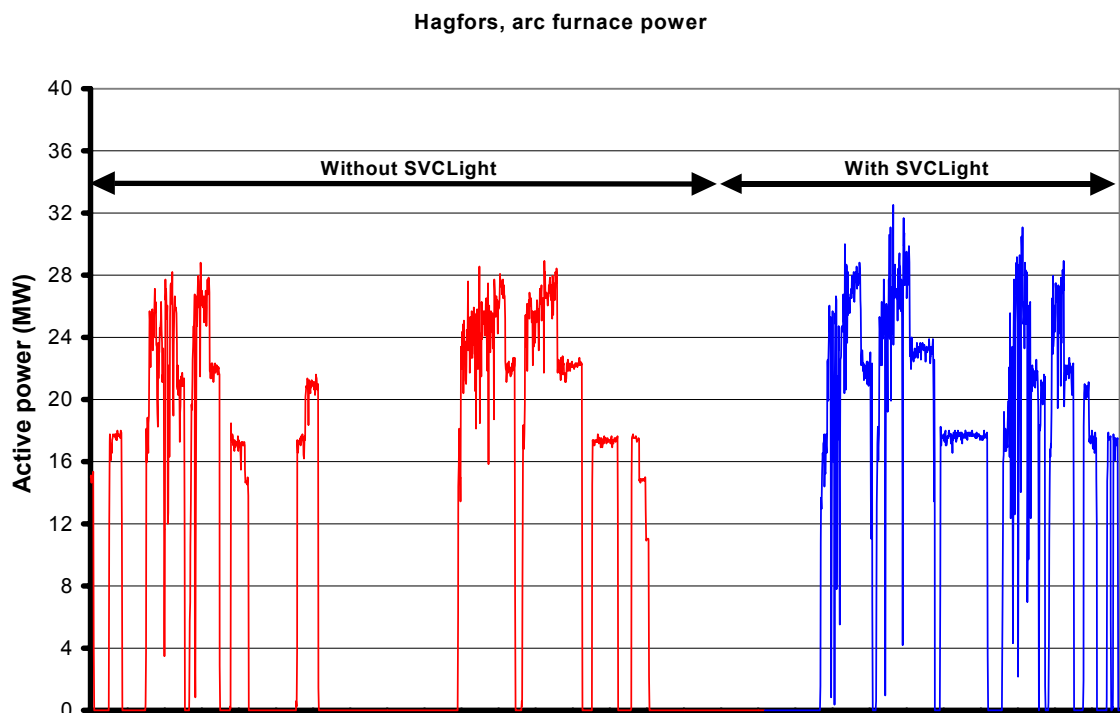

Figure 6.7 Active power into the EAF without and with dynamic STATCOM compensation at Hagfors.

Thus, the active power increase with the compensator in operation gives a furnace production increase from 27,5 to 31,4 tonnes/hour. This increase is attained at a bus voltage of 10.5 kV. Although an even higher rise in active power into the furnace would be possible at voltages higher than 10.5kV at the arc furnace busbar, this might be undesirable from the point of view of other equipment connected to the busbar.

The increase of active power into the EAF enables a faster melt, and thereby a saving in specific energy consumption in the process derivable to lower specific radiation losses from the furnace. This saving accumulates over time, to the benefit of the plant operator. Thus, the energy saving achieved is around 25 kWh/tonne, equal to some 4% saving. Likewise, a saving in specific electrode consumption of about 0.2 kg/tonne is also experienced.

6.4 TRIER, GERMANY

This is a ± 19 Mvar STATCOM (trade marked SVC Light[®] by the manufacturer ABB) installation in operation since 2000 which together with the existing harmonic filters at the site yields an overall reactive compensation range of 0- 38Mvar (capacitive). The installation owned by the steel producer Moselstahlwerk, at Trier, Germany, consists of an a.c. electric arc furnace (EAF) for scrap metal melting rated at 25/30 MVA. The furnace is fed from a 220 kV RWE Net AG grid via an intermediate voltage of 20kV as shown in Figure 6.8. All SVC Light[®] equipment except the phase reactors and the harmonic filters are housed indoors in a small pre-fabricated building. The phase reactors and filters have been erected in a small, fenced outdoor yard. All in all, this gives a very compact layout for the installation as shown in Figure 6.9.

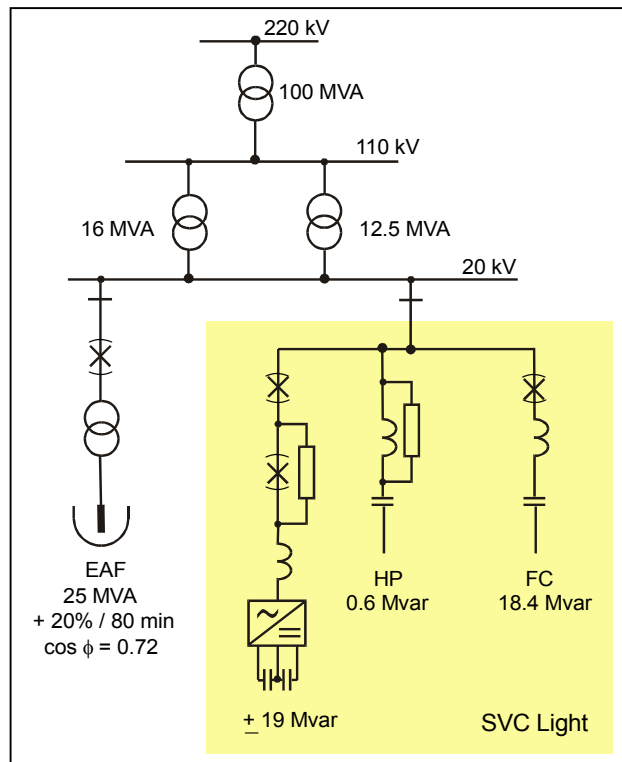

Figure 6.8 Single line diagram of the of STATCOM (trade mark SVC Light) at Trier, Germany (HP is the high pass filter and FC is a fixed capacitor).

The power grid system feeding the arc furnace installation is relatively weak, with insufficient fault level at the Point of Common Coupling to enable operation of the arc furnace while maintaining reasonable power quality at the point of common coupling with other electricity consumers. The flicker performance target of $P_{st95\%} \# 0.74$ set by the utility was met with the additional benefit of better furnace performance with regard to increased available melting power and a decrease in electrode consumption.



Figure 6.9 View of Trier installation showing the SVC Light equipment and the phase reactors.

The voltage sourced converter (VSC) is of a three-level design and utilises Integrated Gate Bipolar Transistors (IGBTs) as switching devices. The converter also uses Pulse-Width Modulation (PWM), with a switching frequency of 1.65 kHz to generate a smooth balanced sinusoidal voltage.

The fast response of the STATCOM enables its use as an active filter in this application. The measured flicker at the 220kV point of common coupling with and without the STATCOM is illustrated in Figure 6.10. The measured long term flicker reduction ratio for the installation was around 4.0, which met the target set for $P_{st95\%}$ #0.74 could be met.

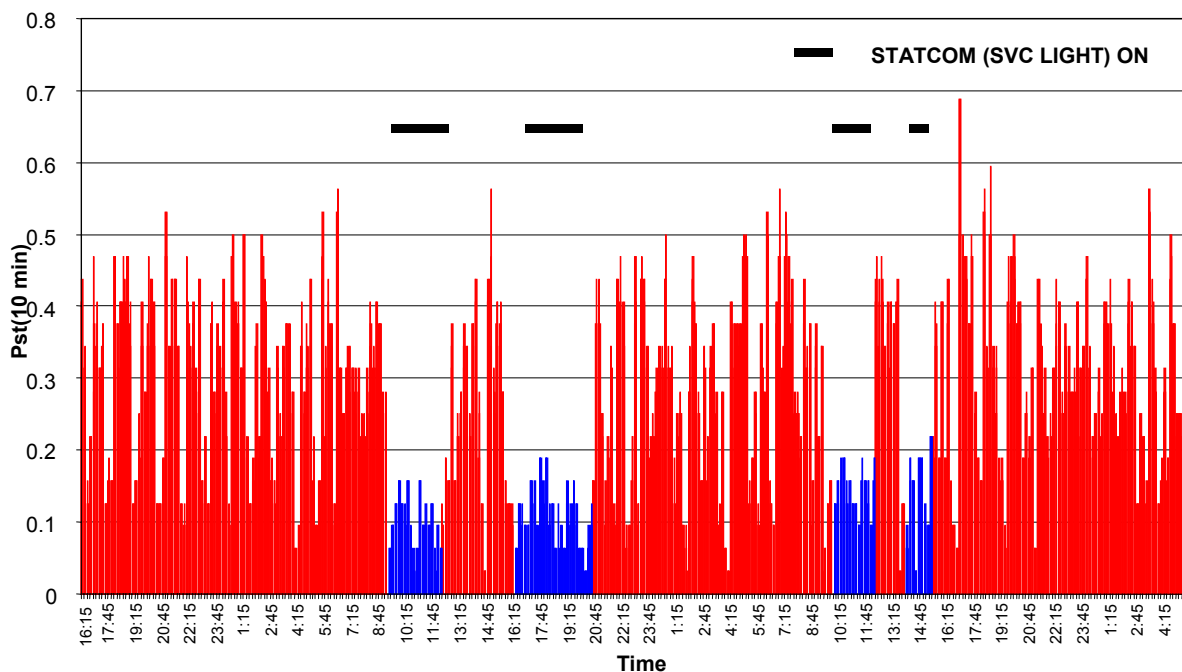

Figure 6.10 Flicker recording at the 220 kV PCC at Trier with and without the STATCOM in operation.

In addition a considerable improvement at the 20 kV furnace busbar voltage variations has been achieved by means of the compensator as illustrated in Figure 6.11. This means that a higher active power input is available into the arc furnace than in the uncompensated case, and hence, a more efficient melting procedure is enabled.

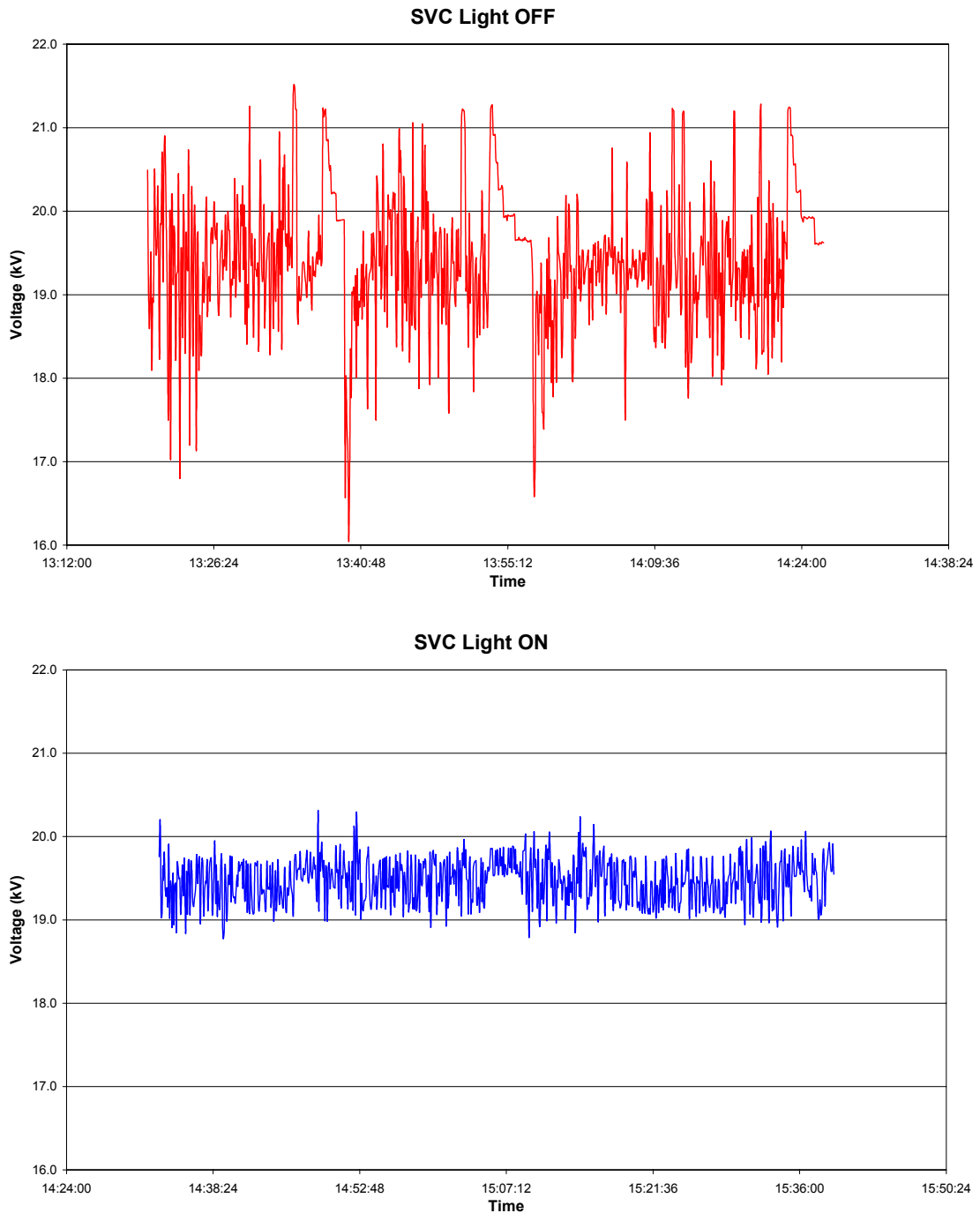

Figure 6.11 The 220kV point of common coupling busbar voltage without and with the compensator at Trier.

6.5 TORNIO, FINLAND

This is a ± 82 Mvar STATCOM (trade marked SVC Light® by the manufacturer ABB) installation which will become operational in 2002 which together with the existing harmonic filters at the site yields an overall reactive compensation range of 0- 164Mvar. The installation owned by the steel producer Avesta Polarit, at Tornio, Finland, consists of an a.c. electric arc furnace (EAF) for scrap metal melting rated at 140/160 MVA. The furnace is fed from the Fingrid 110kV grid via an intermediate voltage of 33kV as shown in Figure 6.12 [6-6].

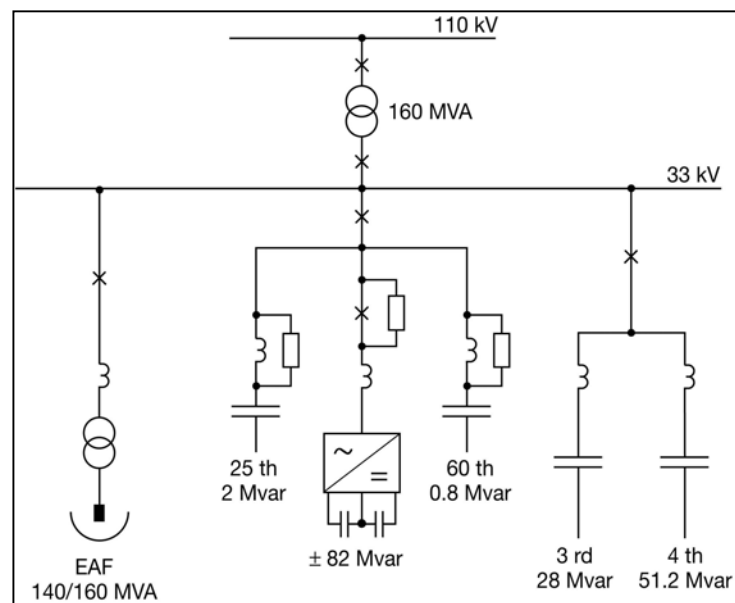

Figure 6.8 Single line diagram of the of STATCOM (trade mark SVC Light) at Tornio, Finland.

The feeding grid is relatively weak. The fault level is quite insufficient to enable operation of the furnace while maintaining reasonable power quality in the grid. Although a dedicated 400kV transmission line was built moving the PCC from the former 110kV level to 400kV the flicker from the existing and the new arc furnaces was still expected to exceed acceptable levels at the 400kV PCC. Although the flicker level at the 400kV PCC did not in itself pose a critical problem, the flicker would be transmitted to other customers via the nearby 110kV transformers.

The voltage sourced converter (VSC) is of a three-level design and utilises Integrated Gate Bipolar Transistors (IGBTs) as switching devices. The converter also uses Pulse-Width Modulation (PWM), with a switching frequency of 1.65 kHz to generate a smooth balanced sinusoidal voltage.

Measurements with and without the STATCOM were performed on site between January 20 and January 24 2003. The Fingrid specification required a guaranteed flicker improvement ratio (FI) of at least 3. The actual measurements have confirmed an improvement ratio of 4.6 in a high load cycle and 5.0 during a medium load cycle operation of the furnace.

6.6 THE STATCOM COMPENSATOR INSTALLATIONS FOR ARC FURNACE FLICKER COMPENSATION IN JAPAN

STATCOM compensators have been applied to arc furnace installations in Japan since 1991. Some 12 examples of such installations with STATCOM ratings from a few Mvar to ± 27 Mvar have been included in Table 6.1 together with a summary of their outline technical characteristics.

6.7 ACKNOWLEDGEMENTS

The authors would like to acknowledge the contributions of Dr. Colin Schauder formerly of Westinghouse/Siemens, who was the lead designer of the STATCOM at Seguin, USA, and who produced the measured performance information on this installation included in this Chapter.

6.8 REFERENCES

- [6-1] Schauder C. and Gyugyi L., "STATCOM for Electric Arc Furnace Compensation," EPRI Workshop - Providing Quality Power To Steel Producers, Chicago, July 13-14, 1995.
- [6-2] Schauder, C.D. "STATCOM for Compensation of Large Electric Arc Furnace Installations", IEEE Power Engineering Society, Summer Meeting 1999, Volume 2, pp1109-1112.
- [6-3] Grünbaum, R., Gustafsson, T. and Johansson, T.: "SVC Light: a Powerful Flicker Mitigator", Iron and Steel Society, 57th Electric Arc Furnace Conference, Nov14-16, 1999, Pittsburgh, PA, USA.
- [6-4] Hager, M., Gustafsson, T., Ingemars, B. Lahtinen, M., Olsson, U. and Agneholm, E. "Measurements Close to a 31.5MVA A.C. Arc Furnace with and without SVC Light", CIGRE Conference Paper 36-202, CIGRE 2002, Paris.
- [6-6] Grünbaum, R., Gustafsson, T., Hasler, J-P., Larsson, T and Lahtinen, M. "STATCOM, a Prerequisite for a Melt Shop Expansion – Performance Experiences", IEEE Power Tech 2003 Conference June 23-26, 2003, Bologna, Italy.

Table 6.1 : Main Existing and Proposed Installations (Page 1 of 4)

Utility / Location	Chiyoda Steel, Japan	Nissin Steel Company, Japan	Tokyo Steel at Okayama, Japan	Mukoyama Steel, Japan	Daido Steel, Japan
Status / Commissioning Date	1991	1990	1991	1994	1994
Rated System Frequency	50 Hz	60 Hz	60 Hz	50 Hz	50 Hz
System Fault Level at the PCC (MVA)					
Arc Furnace Type & Rating					
Nominal STATCOM Mvar Range	±15 MVar	2 x ±10 MVar sets	3 x ±16.5 MVar	±22 MVar	±18 MVar
Converter Configuration	6 x 2.5 MVar bridges connected through magnetics	2 x 4 x 2.5 MVar bridges connected through magnetics	3 x 6 x 2.75 MVar bridges connected through magnetics	2 x 4 x 2.75 MVar bridges connected through magnetics	6 x 3 MVar bridges connected through magnetics
Rated System AC Voltage & Current	22 kV	22 kV	33 kV	22 kV	22 kV
Bridge configuration	3 x 1-phase	3 x 1-phase	3 x 1-phase	3 x 1-phase	3 x 1-phase
Rated Bridge AC Voltage & Current	930 V / 896 A	930 V / 896 A	930 V / 986 A	930 V / 986 A	1.07 kV / 935 A
Arm Configuration	1 unit arm	1 unit arm	1 unit arm	1 unit arm	1 unit arm
Converter Type	VSC	VSC	VSC	VSC	VSC
Rated DC Voltage (positive to negative)	2.25 kV	2.25 kV	2.25 kV	2.25 kV	2.25 kV
Device, Rating & Type	4.5 kV / 3 kA GTO	4.5 kV / 3 kA GTO	4.5 kV / 3 kA GTO	4.5 kV / 3 kA GTO	4.5 kV / 3 kA GTO
Cooling System	Water	Water	Water	Water	Water
Insulation	Air	Air	Air	Air	Air
DC Voltage Control (normal)	Fixed d.c. voltage	Fixed d.c. voltage	Fixed d.c. voltage	Fixed d.c. voltage	Fixed d.c. voltage
Converter Switching Control (normal)	500 Hz PWM carrier per 1-phase bridge 6 kHz overall	500 Hz PWM carrier per 1-phase bridge 8 kHz overall	500 Hz PWM carrier per 1-phase bridge 18 kHz overall	500 Hz PWM carrier per 1-phase bridge 8 kHz overall	500 Hz PWM carrier per 1-phase bridge 6 kHz overall
Basic Purpose and Control Features	Arc furnace flicker control	Arc furnace flicker control	Arc furnace flicker control Var control	Arc furnace flicker control	Arc furnace flicker control
Reference Voltage Location	22 kV	22 kV	33 kV	22 kV	22 kV
Manufacturer	Toshiba	Toshiba	Toshiba	Toshiba	Toshiba

CIGRE STATCOM FOR ARC FURNACE AND FLICKER COMPENSATION
 Chapter 6: Examples of STATCOM Applications for Arc Furnace and Flicker Control
 by Laszlo Gyugyi, Tomas Gustafsson, Shoichi Irokawa and Arslan Erinmez

Table 6.1 : Main Existing and Proposed Installations (Page 2 of 4)

Utility / Location	Ishihara Steel, Japan	Chubu Steel, Japan	Nippon Yakin, Japan	Ube Steel Co. Ltd, Japan	Tokyo Tekko, Hatinohe, Japan
Status / Commissioning Date	1988	1991	1995	1997	1998
Rated System Frequency	50 Hz	60Hz	60 Hz	60 Hz	50 Hz
System Fault Level at the PCC (MVA)					
Arc Furnace Type & Rating					
Nominal STATCOM MVar Range	±10 MVar	±20 MVar	±10 MVar	±18 MVar	±18 MVar
Converter Configuration	4 x 2.5 MVar bridges connected through magnetics	6 x 3.33 MVar bridges connected through magnetics	4 x 4.5 MVar bridges connected through magnetics	4 x 4.5 MVar bridges connected through magnetics	4 x 4.5 MVar bridges connected through magnetics
Rated System AC Voltage & Current	22 kV	22 kV	22 kV	22 kV	22 kV
Bridge configuration	3 x 1-phase		3 x 1-phase	3 x 1-phase	3 x 1-phase
Rated Bridge AC Voltage & Current	930 V / 896 A	1 kV	1.43 kV / 1.049 kA	1.43 kV / 1.049 kA	1.43 kV / 1.049 kA
Arm Configuration	1 unit arm	1 unit arm	1 unit arm	1 unit arm	1 unit arm
Converter Type	VSC	VSC	VSC	VSC	VSC
Rated DC Voltage (positive to negative)	2.25 kV	2 kV	3 kV	3 kV	3 kV
Device, Rating & Type	4.5 kV / 2.5 kA GTO	4.5 kV / 3 kA GTO	6 kV / 2.5 kA GTO	6 kV / 2.5 kA GTO	6 kV / 2.5 kA GTO
Cooling System	Water	Oil-forced air	Water	Water	Water
Insulation	Air	Air	Air	Air	Air
DC Voltage Control (normal)	Fixed d.c. voltage	Fixed d.c. voltage	Fixed d.c. voltage	Fixed d.c. voltage	Fixed d.c. voltage
Converter Switching Control (normal)	500 Hz PWM carrier per 1-phase bridge 4 kHz overall	PWM	390 Hz PWM carrier per 1-phase bridge 3.12 kHz overall	390 Hz PWM carrier per 1-phase bridge 3.12 kHz overall	390 Hz PWM carrier per 1-phase bridge 3.12 kHz overall
Basic Purpose and Control Features	Arc furnace flicker control	Arc furnace flicker control	Arc furnace flicker control	Arc furnace flicker control	Arc furnace flicker control
Reference Voltage Location	22 kV	22 kV	22 kV	22 kV	22 kV
Manufacturer	Toshiba	Mitsubishi	Toshiba	Toshiba	Toshiba

CIGRE STATCOM FOR ARC FURNACE AND FLICKER COMPENSATION
Chapter 6: Examples of STATCOM Applications for Arc Furnace and Flicker Control
by Laszlo Gyugyi, Tomas Gustafsson, Shoichi Irokawa and Arslan Erinmez

Table 6.1: Main Existing and Proposed Installations (Page 3 of 4)

Utility / Location	Tokyo Tekko, Oyama, Japan	Tokyo Tekko, Oyama, Japan	Pacific Gas & Electric Co. at Paul Sweet Substation, CA, USA	Structural Metals Inc., Seguin, Texas, USA
Status / Commissioning Date	1999	1999	1998	1998
Rated System Frequency	50 Hz	50 Hz	60 Hz	60 Hz
System Fault Level at the PCC (MVA)				
Arc Furnace Type & Rating				
Nominal STATCOM MVA _r Range	±18 MVA _r	±27 MVA _r	±43 MVA _r STATCOM with 20 MVA _r FC	±80 MVA _r STATCOM with 60 MVA _r FC
Converter Configuration	4 x 4.5 MVA _r bridges connected through magnetics	6 x 4.5 MVA _r bridges connected through magnetics	2 x 21.5 MVA _r bridges connected through magnetics	4 x 20 MVA _r bridges connected through magnetics
Rated System AC Voltage & Current	22 kV	22 kV	115 kV	15 kV
Bridge Configuration	3 x 1-phase	3 x 1-phase	3-phase	3-phase
Rated Bridge AC Voltage & Current	1.43 kV / 1.049 kA	1.43 kV / 1.049 kA	8.7 kV	8.1 kV
Arm Configuration	1 unit arm	1 unit arm	5 + 5 units in series	5 + 5 units in series
Converter Type	VSC	VSC	3-level VSC	3-level VSC
Rated DC Voltage (positive to negative)	3 kV	3 kV	12.9 kV	12.0 kV
Device, Rating & Type	6 kV / 2.5 kA GTO	6 kV / 2.5 kA GTO	4.5 kV / 4.0 kA GTO	4.5 kV / 4 kA GTO
Cooling System	Water	Water	Ethylene glycol & water	Water
Insulation	Air	Air	Air	Air
DC Voltage Control (normal)	Fixed d.c. voltage	Fixed d.c. voltage	Variable d.c. voltage	Fixed d.c. voltage
Converter Switching Control (normal)	390 Hz PWM carrier per 1-phase bridge 3.12 kHz overall	390 Hz PWM carrier per 1-phase bridge 4.68 kHz overall	1 pulse AM 24 pulse waveform	1 pulse PWM
Basic Purpose and Control Features	<ul style="list-style-type: none"> Arc furnace flicker control 	<ul style="list-style-type: none"> Arc furnace flicker control 	<ul style="list-style-type: none"> Voltage control of transmission line 	<ul style="list-style-type: none"> Flicker control of Arc Furnace
Reference Voltage Location	22 kV	22 kV	115 kV	n/a
Manufacturer	Toshiba	Toshiba	Siemens (Westinghouse)	Siemens (Westinghouse)

CIGRE STATCOM FOR ARC FURNACE AND FLICKER COMPENSATION
Chapter 6: Examples of STATCOM Applications for Arc Furnace and Flicker Control
by Laszlo Gyugyi, Tomas Gustafsson, Shoichi Irokawa and Arslan Erinmez

Table 6.1: Main Existing and Proposed Installations (Page 4 of 4)

Utility / Location	Uddeholm Tooling, Hagfors, Sweden	Moselstahlwerke, Trier, Germany	Avesta Polarit, Tornio, Finland
Status / Commissioning Date	1999	2000	2002
Rated System Frequency	50 Hz	50 Hz	50 Hz
System Fault Level at the PCC (MVA)	1000 MVA		
Arc Furnace Type & Rating	EAF: 31.8/37.8 MVA LF:5.9/7.7 MVA	EAF: 25 MVA/30 MVA	EAF: 160 MVA
Nominal STATCOM MVar Range	44 Mvar type SVC Light® ±22Mvar	38 Mvar type SVC Light® ±19Mvar	164 Mvar type SVC Light® ± 82 Mvar
Converter Configuration	3-level direct connected to 10.5 kV	3-level direct connected to 20 kV	3-level direct connected to 33 kV
Rated System AC Voltage & Current	10.5 kV	20 kV	33 kV
Bridge Configuration	3-level	3-level	3-level
Rated Bridge AC Voltage & Current	10.5 kV/1210 A	20 kV/550 A	33 kV/1435 A
Arm Configuration	-	-	-
Converter Type	3-level NPC	3-level NPC	3-level NPC
Rated DC Voltage (positive to negative)	-	-	-
Device, Rating & Type	IGBT, 2.5 kV/ 1.8 kA	IGBT, 2.5 kV/1.3 kA	IGBT, 2.5 kV/1.8 kA
Cooling System	Water/water	Water/water	Water/water
Insulation	Air	Air	Air
DC Voltage Control (normal)	Fixed d.c. voltage	Fixed d.c. voltage	Fixed d.c. voltage
Converter Switching Control (normal)	1650 Hz, PWM	1650 Hz, PWM	1650 Hz, PWM
Basic Purpose and Control Features	Arc furnace flicker control	Arc furnace flicker control	Arc furnace flicker control
Reference Voltage Location	-	-	-
Manufacturer	ABB	ABB	ABB

Appendix A STATES OF THE A.C. ARC FURNACE

by Guillaume de Preville, Alstom

There are seven operational states for an a.c. arc furnace, with distinct values of furnace impedance, which are of particular interest from an arc furnace compensation point of view. These seven states correspond to a.c. arc furnace operation with:

1. All three phases short circuited;
2. Two phases short circuited and the third phase in nominal operation;
3. Two phases short circuited and the third phase on open circuit;
4. Only one phase short circuited, one phase on open circuit and one phase in nominal operation;
5. All three phases in nominal operation;
6. Two phases in nominal operation and one phase short circuited; and
7. Two phases in nominal operation and one phase open circuit.

The cases of operation with all three phases on open circuit and with two phases on open circuit are not of particular interest.

The arc furnace impedance values corresponding to an a.c. arc furnace of 100MVA rating connected at 33kV, are given in the Tables below as a representative example of operation in the different states of operation. The impedances are all expressed in per unit based on arc furnace transformer MVA rating and rated primary voltage.

During the “Boring” period of arc furnace operation:

Case	Phase 1	Phase 2	Phase 3
1	0.0550 + j 0.5729	0.0550 + j 0.5729	0.0550 + j 0.5729
2	0.0550 + j 0.5729	0.0550 + j 0.5729	0.6373 + j 0.5729
3	0.0550 + j 0.5729	0.0550 + j 0.5729	Infinity
4	0.0550 + j 0.5729	0.6373 + j 0.5729	Infinity
5	0.6373 + j 0.5729	0.6373 + j 0.5729	0.6373 + j 0.5729
6	0.6373 + j 0.5729	0.6373 + j 0.5729	0.0550 + j 0.5729
7	0.6373 + j 0.5729	0.6373 + j 0.5729	Infinity

During the “Melting” period of arc furnace operation:

Case	Phase 1	Phase 2	Phase 3
1	0.0221 + j 0.2900	0.0221 + j 0.2900	0.0221 + j 0.2900
2	0.0221 + j 0.2900	0.0221 + j 0.2900	0.4635 + j 0.2900
3	0.0221 + j 0.2900	0.0221 + j 0.2900	Infinity
4	0.0221 + j 0.2900	0.4635 + j 0.2900	Infinity
5	0.4635 + j 0.2900	0.4635 + j 0.2900	0.4635 + j 0.2900
6	0.4635 + j 0.2900	0.4635 + j 0.2900	0.0221 + j 0.2900
7	0.4635 + j 0.2900	0.4635 + j 0.2900	infinity

During the “Refining” period of operation:

Case	Phase 1	Phase 2	Phase 3
1	$0.0292 + j 0.3503$	$0.0292 + j 0.3503$	$0.0292 + j 0.3503$
2	$0.0292 + j 0.3503$	$0.0292 + j 0.3503$	$0.6067 + j 0.3503$
3	$0.0292 + j 0.3503$	$0.0292 + j 0.3503$	Infinity
4	$0.0292 + j 0.3503$	$0.6067 + j 0.3503$	Infinity
5	$0.6067 + j 0.3503$	$0.6067 + j 0.3503$	$0.6067 + j 0.3503$
6	$0.6067 + j 0.3503$	$0.6067 + j 0.3503$	$0.0292 + j 0.3503$
7	$0.6067 + j 0.3503$	$0.6067 + j 0.3503$	infinity

Appendix B: COMPENDIUM OF STATCOM CONTROL METHODS

Prepared by Guillaume de Preville, Alstom

This Appendix discusses further control methods, based on D-Q compensation theory, to the methods described in Chapter 3.

B1 I_D, I_Q COMPENSATION THEORY

The power system at the point of connection to the disturbing load busbar is characterised by its no load voltage E_S and its impedance Z_S . This impedance is derived from the three-phase short-circuit fault level S_{sc} at the point of common coupling as

$$S_{sc} = 3 (E_S^2 / Z_S)$$

where $Z_S = R + jX$

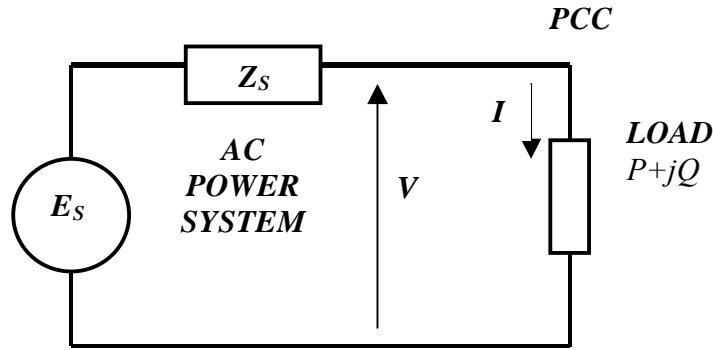

Figure B.1 Representation of the power system and the disturbing load at the point of common coupling.

At the point of common coupling, the voltage is V , and the load consumes active power P and reactive power Q .

The voltage at the point common coupling is given by the following equations, assuming per unit quantities on a base of nominal rating of the arc furnace transformer S_{nom} and the nominal rated voltage V_{nom} with the three-phase short-circuit fault MVA infeed from the system at the point of common coupling equal to S_{sc} .

$$V = E_S - R_S I - L_S dI / dt$$

so the voltage drop is

$$\Delta V = R_S I + L_S dI / dt$$

with $V = V_d$ $\Delta V = \Delta V_d + j \Delta V_q$ $I = I_d - j I_q$

$$\Delta V_d = \omega L_S I_q + R_S I_d + 1 / \omega L_S \omega dI_d / dt$$

$$\Delta V_q = \omega L_S I_d - R_S I_q - 1/\omega L_S \omega dI_q/dt \quad (\text{Eqn B.1})$$

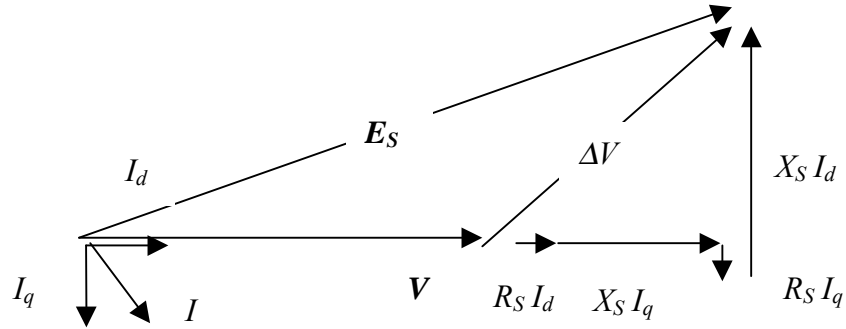

Figure B.2 Vector diagram corresponding to equation B.1.

Ideal compensation of the arc furnace can be achieved by following the following step by step procedure described below.

1. Step 1: The first step in achieving full compensation is to compensate the reactive current drawn by the arc furnace such that $I_q = 0$ by injecting a current reference equal to $(-I_q)$ into the compensator control system. Thus

$$I_{qref} = -I_q \quad (\text{Eqn B.2})$$

With $I_q=0$ equation B.1 becomes

$$\begin{aligned} \Delta V_d &= R_S I_d + (1/\omega) \omega L_S dI_d/dt \\ \Delta V_q &= \omega L_S I_d \end{aligned} \quad (\text{Eqn B.3})$$

as shown in Figure B.3. Compensating for the reactive part of the arc furnace current reduces the magnitude of the voltage drop ΔV .

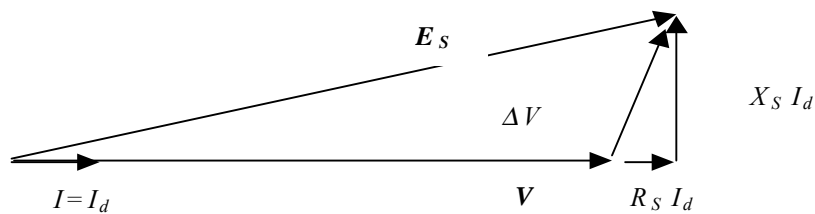

Figure B.3 Vector diagram corresponding to equation B.3.

2. Step 2: Since the voltage fluctuation due to the active power drawn by the arc furnace remains, in the second step compensation of the active power fluctuation is attempted by injecting an additional current $I_q = -(R_s / X_s) I_d$ to the reference of the compensator control system, i.e., injecting capacitive power proportional to I_d , to compensate the remaining voltage drop. So the reactive current reference for the shunt compensator becomes:

$$I_{qref} = -I_q - (R_s / X_s) I_d \quad (\text{Eqn B.4})$$

Substituting this reference current for I_q in equation B.1 gives

$$\begin{aligned} \Delta V_d &= +(1/\omega) X_s dI_d / dt \\ \Delta V_q &= X_s (1 + R_s^2 / X_s^2) I_d + (1/\omega) R_s dI_d / dt \end{aligned} \quad (\text{Eqn B.5})$$

This is illustrated in Figure B.4.

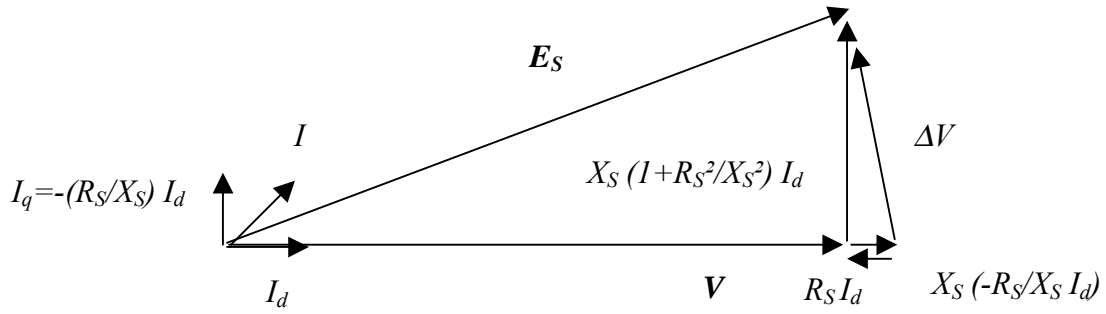

Figure B.4 Vector diagram corresponding to equation B.5.

3. Step 3: After the compensation of real power fluctuations attempted in the second step the ideal compensation objective of $V=E_s$ is still not fully realised because a small voltage drop still remains as;

$$E_s^2 = V_s^2 + X_s^2 (1 + R_s^2 / X_s^2)^2 I_d^2$$

$$V = \sqrt{E_s^2 - X_s^2 (1 + R_s^2 / X_s^2)^2 I_d^2} \quad \text{or}$$

$$V = E_s \sqrt{1 - (X_s^2 (1 + R_s^2 / X_s^2)^2 I_d^2 / E_s^2)} \neq E_s$$

In order to achieve $V=E_s$ the following current is added to the compensator control reference signal

$$I_q = -(R_s / X_s) I_d - (S_{nom} / 2 / S_{sc}) I_d^2$$

The reactive current reference for the shunt compensation thus becomes

$$I_{qref} = -I_q - (R_s / X_s) I_d - (S_{nom} / 2 / S_{sc}) I_d^2 \quad (\text{Eqn B.6})$$

Substituting in equation B.1 we obtain

$$\begin{aligned} \Delta V_d &= -X_s (S_{nom} / 2 / S_{sc}) I_d^2 + (1/\omega) X_s dI_d / dt \\ \Delta V_q &= -X_s (1 + R_s^2 / X_s^2) I_d + R_s (S_{nom} / 2 / S_{sc}) I_d^2 + (1/\omega) R_s dI_d / dt + (1/\omega) X_s (S_{nom} / 2 / S_{sc}) dI_d^2 / dt \end{aligned} \quad (\text{Eqn B.7})$$

This is illustrated in Figure. B.5. This compensation achieves $V=E_s$ in steady state, because:

$$E_s^2 = [V - X_s (S_{nom} / 2 / S_{sc}) I_d^2]^2 + [X_s (1 + R_s^2 / X_s^2) I_d + R_s (S_{nom} / 2 / S_{sc}) I_d^2]^2 \approx V^2$$

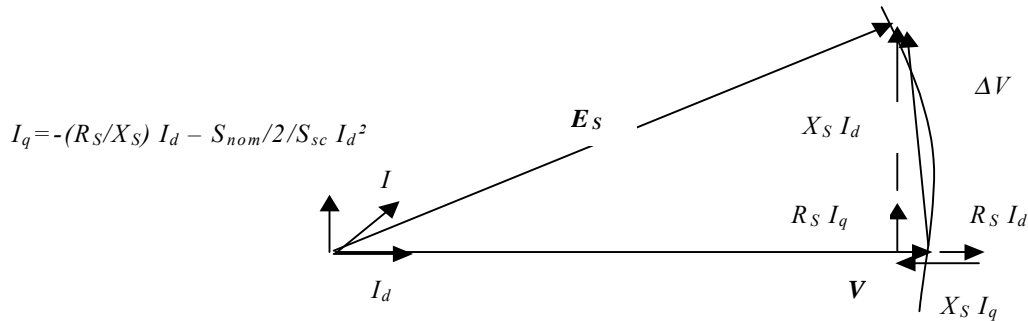

Figure B.5 Vector diagram for equation B.7.

Figure B.6 shows the reactive power requirements for compensation of an arc furnace where $S_{sc} = 250\text{MVA}$, $S_{nom} = 40\text{MVA}$, power system $R/X = 1/20$ and the voltage at the point of common coupling is 11kV .

The first curve (1) represents the needed capacitive power with compensation method ($I_q = -R_s/X_s * I_d$). The two other curves represent the real compensation requirement to achieve ($V = E_s$), in curve (3) and the approximate compensation method ($I_q = -R_s/X_s * I_d - S_{nom}/2/S_{sc} * I_d^2$) in curve (2).

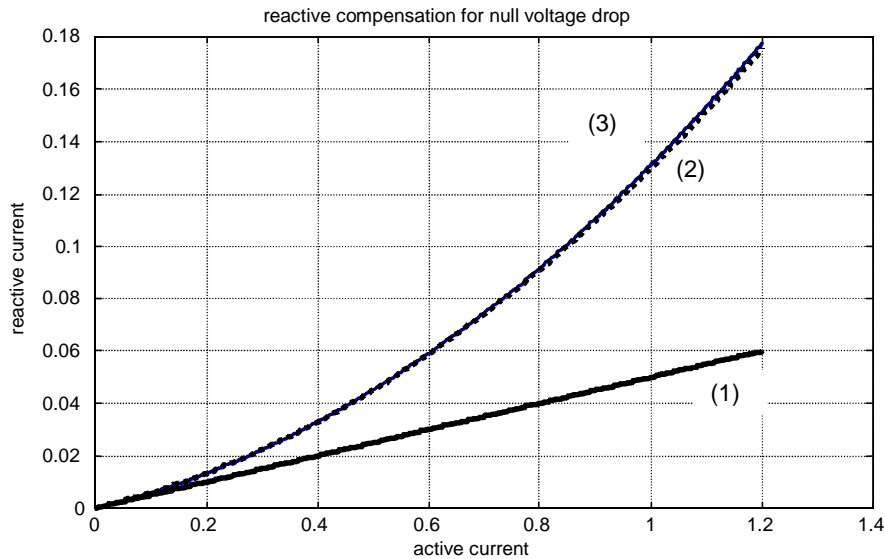

Figure B.6 Curves demonstrating the compensation requirements.

In Figure B.7 shows the percentage voltage drop for $I_q=0$ compensation method in curve (1), for $I_q=-R_s/X_s*I_d$ compensation method in curve (2) and for $I_q=-(R_s/X_s*I_d+S_{nom}/2/S_{sc}*I_d^2)$ compensation method in curve (3), with curve (4) representing the perfect (ideal) compensation where the voltage drop is equal to zero.

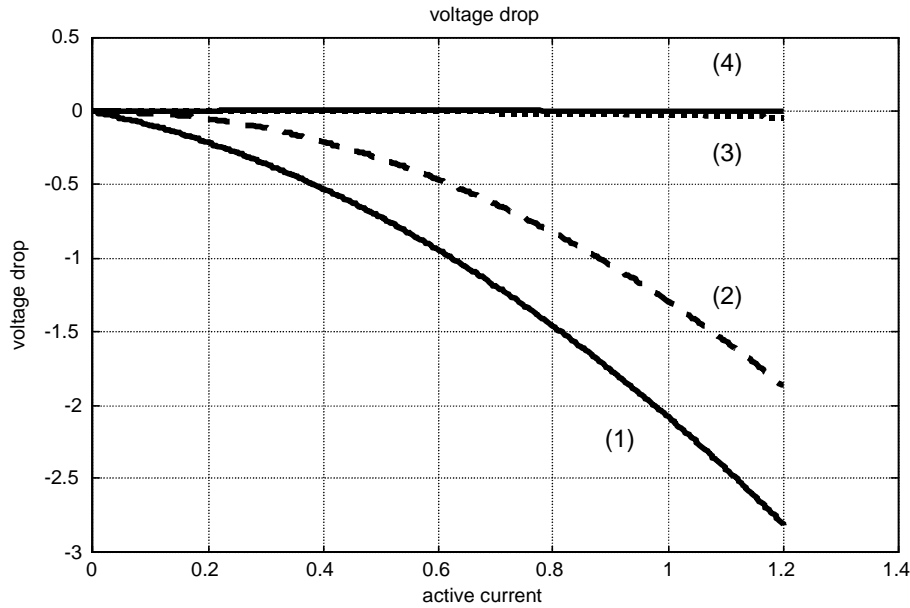

Figure B.7 Curves demonstrating the voltage drop obtainable for different compensation techniques.

Assuming that the furnace consumes active power and reactive power that could be described as $P = P_{dc} + P_f$ (continuous active power and fluctuating active power) and $Q = Q_{dc} + Q_f$ (continuous reactive power and fluctuating reactive power), the previous demonstration could be the first way to compensate the voltage fluctuation.

The STATCOM compensate the full reactive power absorbed by the furnace, and delivers to the network some capacitive power Q to reduce the voltage fluctuation. This is the way with classical SVC with thyristors and STATCOM.

Making $\Delta V_d = f(\Delta V_q)$ assures that $V = \text{Constant}$. The load reactive power is fully compensated and a capacitive power in accordance with the active power consumption is supplied to the power system. It means that we can only work on the voltage in the direct axis. The compensating device only generates reactive power at the point of common coupling. This is the purpose of classical SVC with thyristors and STATCOM with classical control.

With this, the network supplies the full active power $P_{dc} + P_f$ and absorbs the reactive power $Q = R/X*(P_{dc} + P_f) + 1/w*dP/dt + (P_{dc} + P_f)^2/(2*S_{sc})$ supplied by the compensator as shown in Figure B.8.

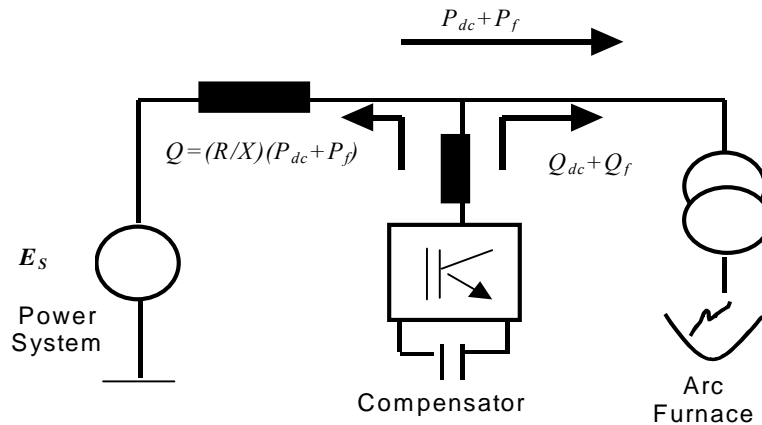

Figure B.8 Compensation by reactive power injection only by the compensator.

The second way for full compensation is to compensate directly the fluctuating active power P_f by the compensator and the full reactive power $Q_{dc} + Q_f$ by the compensator. With this method, the network supplies only the continuous active power, and the compensator supplies the full reactive power and the fluctuating active power P_f of the furnace. Alternatively, the compensator can supply to the network a continuous capacitive power $Q = (R/X)P_{dc} + P_{dc}^2 / (2S_{sc})$ only to compensate the continuous voltage drop as shown in Figure B.9.

The control method achieving $\Delta V_d = \text{Constant}$ and $\Delta V_q = \text{Constant}$ ensures that $V = \text{Constant}$. This method of compensation is only possible in the flicker frequency band (from 0.5Hz to 35Hz) with a STATCOM compensator. It is not possible with a classical SVC utilising thyristors, because classical SVC can only supply reactive power. Effective flicker compensation requires compensation of both active and reactive power fluctuations produced by the arc furnace. It means that control action is required both on the voltages in the direct axis and in quadrature axis. Active and reactive power are generated by the compensating device. This could be ideally carried out by the STATCOM with appropriate control and energy storage element (DC bus) capability. Of course, it will be difficult to compensate the fluctuating active power of the arc furnace in full, as this would require a very large energy storage capability. But in some applications compensation of only a proportion of the fluctuating active power will further improve the flicker reduction performance.

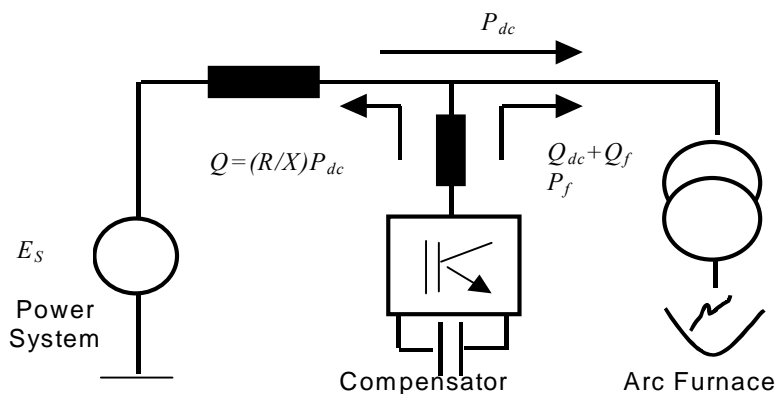

Figure B.9 Compensation by both reactive and active power injection by the compensator.

This demonstrates the two further possible ways of eliminating the voltage fluctuation due to active and reactive power consumption of the arc furnace.

B2 CONTROL SCHEMES FOR STATCOM

This Section presents the different possibilities available to the control system designer for the control of STATCOM used for flicker mitigation. First the principal control action to enable the control of the STATCOM reactive power output will be presented. Then two different methods of control used in STATCOM for flicker mitigation in industrial networks. The first method is for reactive power control based on vector control principle, and the next is one derived from active filtering applications. This will be followed by the description of two control approaches, one by controlling the STATCOM current, the other by the line current, respectively. Finally, for these latter two different approaches, an alternative approach for flicker mitigation will be presented

B2.1 STATCOM Control Principles

The voltage sourced converter (VSC) forms the basic building block of STATCOM compensators used in Power transmission system applications as described in Chapter 3 and reference [B-1]. The operation of the VSC converter and the STATCOM compensator as a reactive power source providing essentially a voltage support role can be described as follows. The single line diagram of the basic shunt connected STATCOM scheme for reactive power supply to the transmission system is shown in Figure B.10, where V is the power system voltage and E is the controllable output voltage of the VSC at the fundamental frequency of the power system.

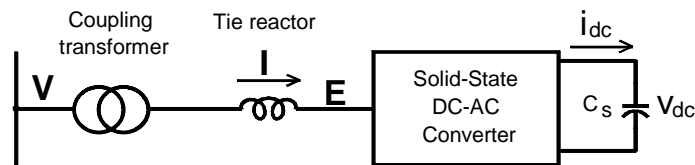

Figure B.10 Voltage-sourced Converter Scheme for Reactive Power Generation.

The active and reactive power exchanged between the network is given by:

$$P_{STATCOM} = V * E / X * \sin \delta$$

$$Q_{STATCOM} = V / X * (V - E * \cos \delta)$$

Since the STATCOM is essentially a lossless device, no active power exchanged occurs and $\delta = 0$. Thus

$$Q_{STATCOM} = V / X * (V - E)$$

From a d.c. input voltage source, provided by the charged capacitor C , the converter produces a set of controllable three-phase output voltages (\mathbf{E}) at the fundamental frequency of the a.c. power system. Each output voltage is in phase with, and coupled to the corresponding a.c. system voltage (\mathbf{V}) via a relatively small (0.1-0.15 p.u.) reactance, which typically may be the per phase leakage inductance of the coupling transformer. By varying the amplitude of the output voltages produced, the reactive power exchange between the converter and the a.c. system can be controlled in a manner similar to that of the rotating synchronous compensator as illustrated in Figure B.11.

If the amplitude E of the output voltage phasor (\mathbf{E}) is increased above the amplitude V of the a.c. system voltage phasor (\mathbf{V}), then the current phasor leads the voltage phasor and current flows from the converter to the a.c. system, and the converter generates (or supplies) reactive (capacitive) power to the a.c. system. If the amplitude of the output voltage phasor is decreased below that of the a.c. system, voltage phasor then the reactive current flows from the a.c. system to the converter, and the converter absorbs reactive (inductive) power from the a.c. system. If the amplitude of the output voltage is equal to that of the a.c. system voltage, the reactive power exchange is zero.

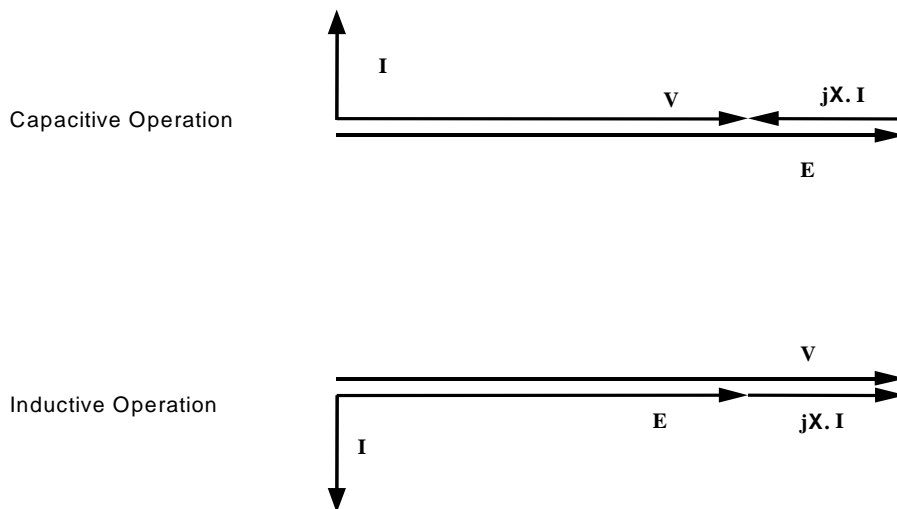

Figure B.11 Capacitive and inductive behaviour of STATCOM.

As described in reference [B-1] with the currently available semiconductor switching devices, the higher rated output STATCOM for power system applications generally utilise multi-pulse and multi-level converter structures for harmonic elimination purposes in preference to pulse width modulation (PWM) techniques. This also reduces the switching losses of the converter. This method of control could be termed as “indirect control”.

However, for smaller rated STATCOM for industrial applications PWM techniques are currently used. This technique permits the variation of the amplitude of the voltage V without the need to modify the phase angle between the network voltage V and the converter voltage E .

The control principle is simply that the reactive power is controlled by the magnitude of the voltage and the active power is controlled by the angle between the VSC voltage and the network voltage. As this angle is small, we can say:

$$P_{STATCOM} = V * E / X_s * \delta$$

$$Q_{STATCOM} = V * (V - E) / X$$

Therefore

$$E = V - X * Q_{STATCOM} / V$$

$$\delta = P_{STATCOM} / (Q_{STATCOM} * V - V^2 / X)$$

Thus the general principle of this type of control which could be termed “direct control” is illustrated in Figure B.13.

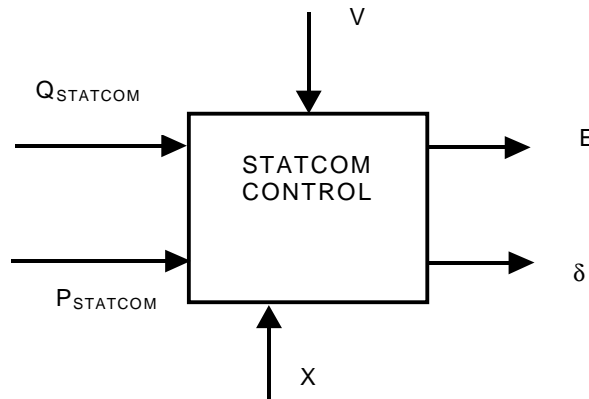

Figure B.13 Principle of “direct” STATCOM control.

This represents the principle of “direct” control of STATCOM. In practice the control can be realised in different ways as will be described in the following Section.

B2.2 Vector Control

B2.2.1 Principles of Vector Control

From Figure B.15 the following equation can be written

$$\underline{V} = -L * \frac{d\underline{I}}{dt} - R * \underline{I} + \underline{E}$$

where

\underline{V} = the power system voltage vector

\underline{E} = the STATCOM voltage vector

\underline{I} = the STATCOM current vector

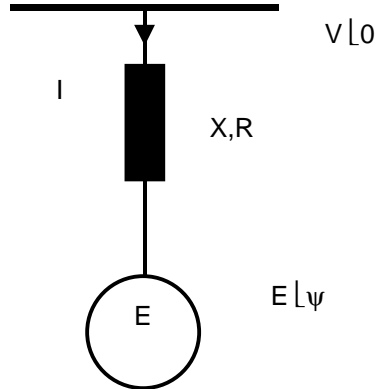

Figure B.15 Representation of STATCOM.

In polar form these vectors can be expressed as:

$$\underline{\mathbf{V}} = V e^{j\omega t}$$

$$\underline{\mathbf{E}} = E e^{j\omega t - j\psi} = E e^{j\omega t} e^{-j\psi}$$

$$\underline{\mathbf{I}} = I e^{j\omega t - j\phi} = I e^{j\omega t} e^{-j\phi}$$

giving

$$d\underline{\mathbf{I}}/dt = -j\omega I e^{j\omega t - j\phi} + e^{j\omega t} d[Ie^{-j\phi}]/dt$$

and

$$V = j\omega L I e^{-j\phi} - L d[Ie^{-j\phi}]/dt - R I e^{-j\phi} + E e^{-j\psi}$$

If we substitute $\omega t = 0$ then:

$$\underline{\mathbf{I}} = I e^{-j\phi} = I_d + jI_q;$$

$$\underline{\mathbf{V}} = V = V_d$$

$$\underline{\mathbf{E}} = E e^{-j\psi} = E_d + jE_q;$$

Then:

$$V_d = -\omega L I_q + L dI_d/dt + R I_d + E_d$$

$$0 = +\omega L I_d + L dI_q/dt + R I_q + E_q$$

So the STATCOM voltage components E_d and E_q are given by:

$$E_d = V_d + \omega L I_q - L dI_d/dt - R I_d \quad (\text{Eqn B 8})$$

$$E_q = -\omega L I_d - L dI_q/dt - R I_q$$

Two different control schemes can be used to implement the vector control principle, namely the “Direct Loop Control” or the “Decoupled Loop Control” schemes as will be described below.

B2.2.2 Direct Loop Control Scheme

From equation B.8, we can directly express the reference voltage in the rotating frame synchronous with the network voltage as:

$$E_d^* = V_d + L^*w^*I_q^* - L^*dI_d^*/dt - R^*I_d^* \quad (\text{Eqn B.9})$$

$$E_q^* = -L^*w^*I_d^* - L^*dI_q^*/dt - R^*I_q^*$$

where I_d^* and I_q^* are the required active and reactive current components of the STATCOM. I_q^* could be calculated from the measured arc furnace current and I_d^* is derived from the error (deviation) signal of the d.c. capacitor voltage. Figure B.16 shows the block diagram of the control:

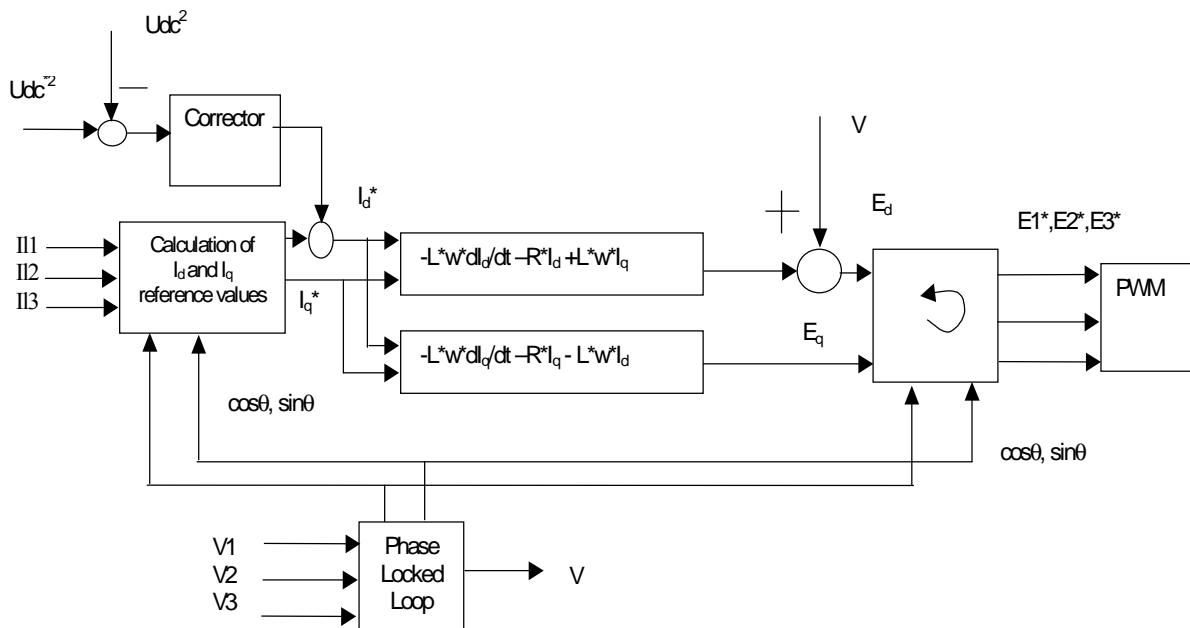

Figure B.16 “Direct Loop” control scheme for STATCOM.

The three load (arc furnace and filter) phase currents are transformed into (α, β) orthogonal co-ordinates using the Clarke transformation:

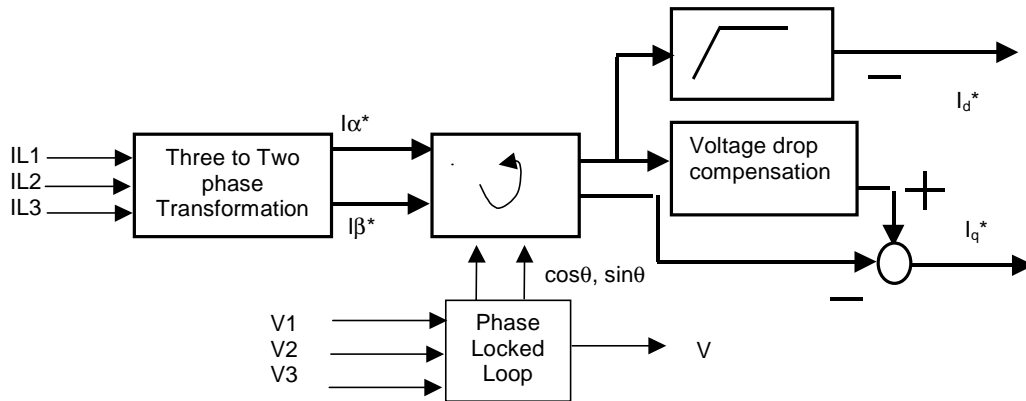

Figure B.18 Calculation of active and reactive current for the Decoupled Control Loop scheme.

From the three load (arc furnace and filter bank) currents, the two phase currents I_α and I_β are calculated. These two currents are demodulated with the $\cos\theta$, $\sin\theta$ signals coming from the Phase Locked Loop (PLL), and the demodulated currents after some specific treatment (specific filtering, and modification of reactive component by adding a part of active component as shown in Eq B.6) give the active and the reactive power references, I_d^* and I_q^* .

B.2.3 Active Filtering Control:

Another possibility for the control of the STATCOM is to control the three currents of STATCOM. This method is derived from the active control used in industrial active filtering devices. Figure B.19 shows such a control scheme for STATCOM which gives the three a.c. references for currents $I_{ref1}(t)$, $I_{ref2}(t)$, $I_{ref3}(t)$.

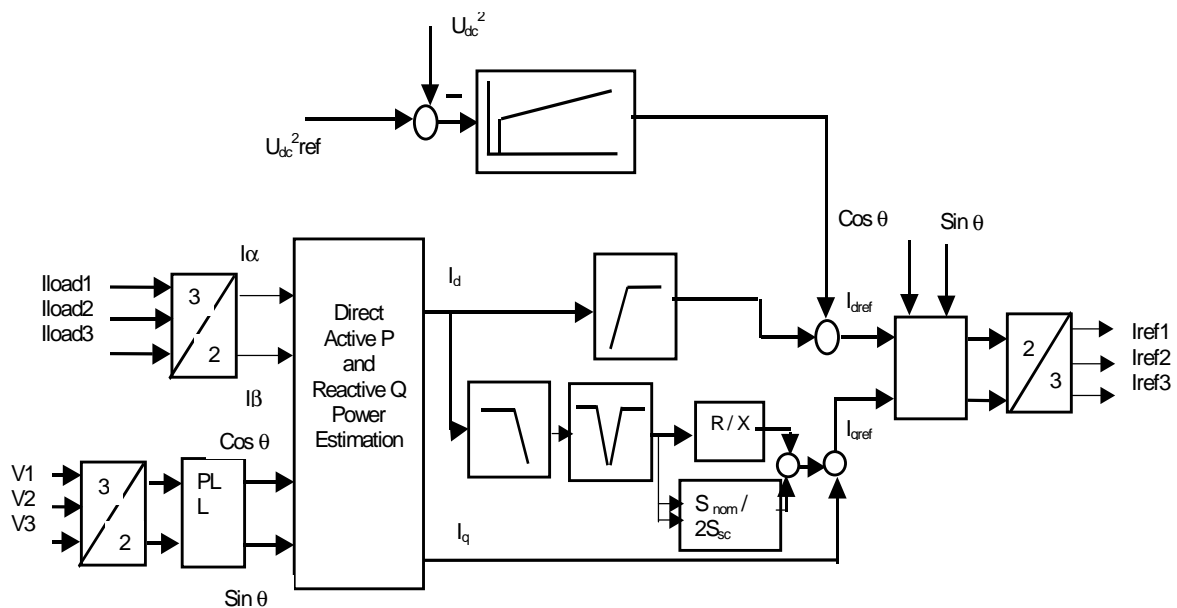

Figure B.19 The derivation of current references for Active Filtering Control for STATCOM.

The current control is then carried out phase by phase as shown in the Figure B.20.

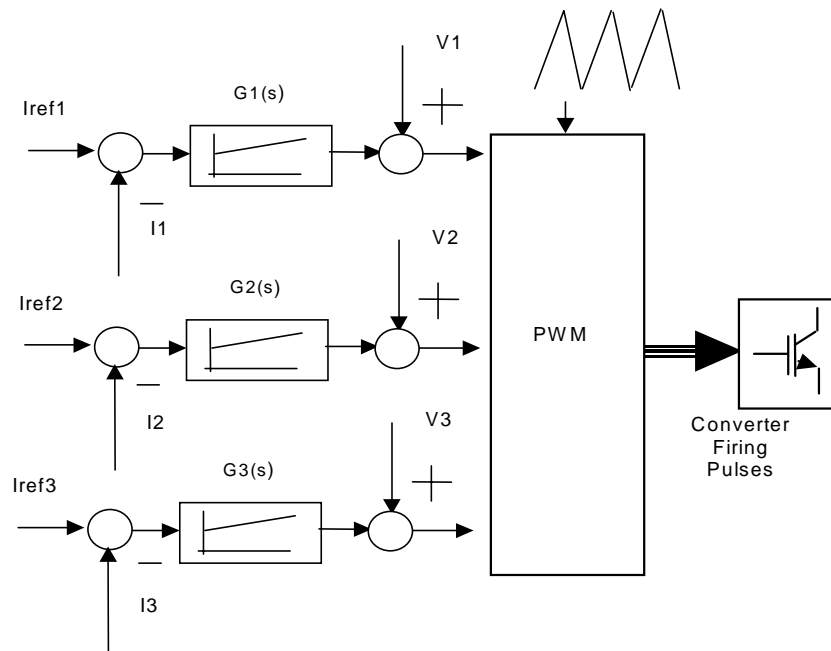

Figure B.20 Basis of the implementation of STATCOM current control for Active Filter Control from derived current references (the anti wind-up circuits not included).

Figures B 21, B22 and B23 give the results of the simulations of the Active Filter Control of STATCOM current obtained with a 4 level Foch Meynard (flying capacitor) type voltage sourced converter.

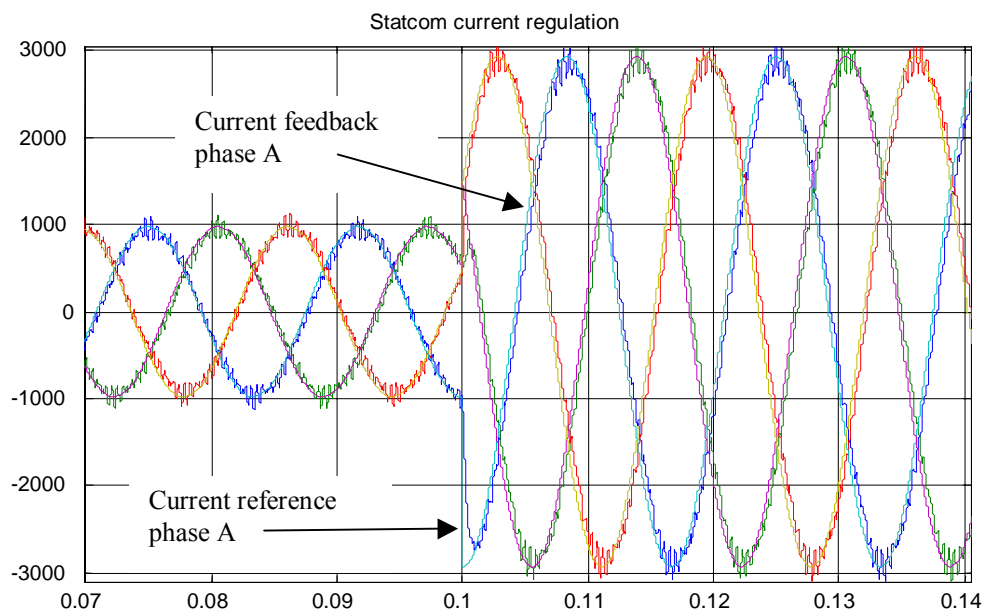

Figure B.21 Simulation illustrating the response of the STATCOM to a change in the phase A current reference.

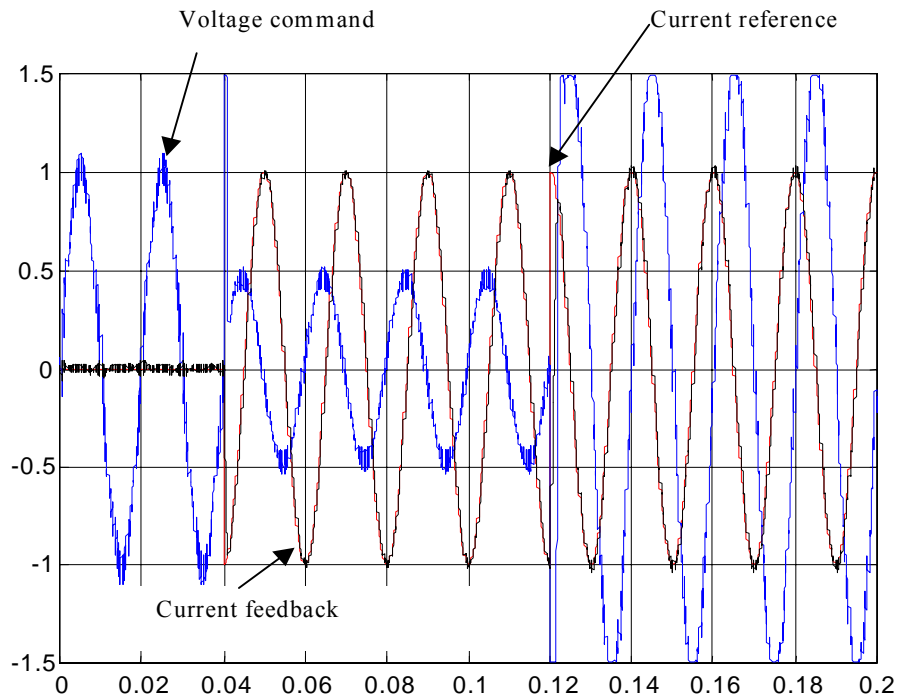

Figure B.22 Current regulation of STATCOM. Step change applied to the current reference causing the STATCOM output to swing from fully inductive to fully capacitive.

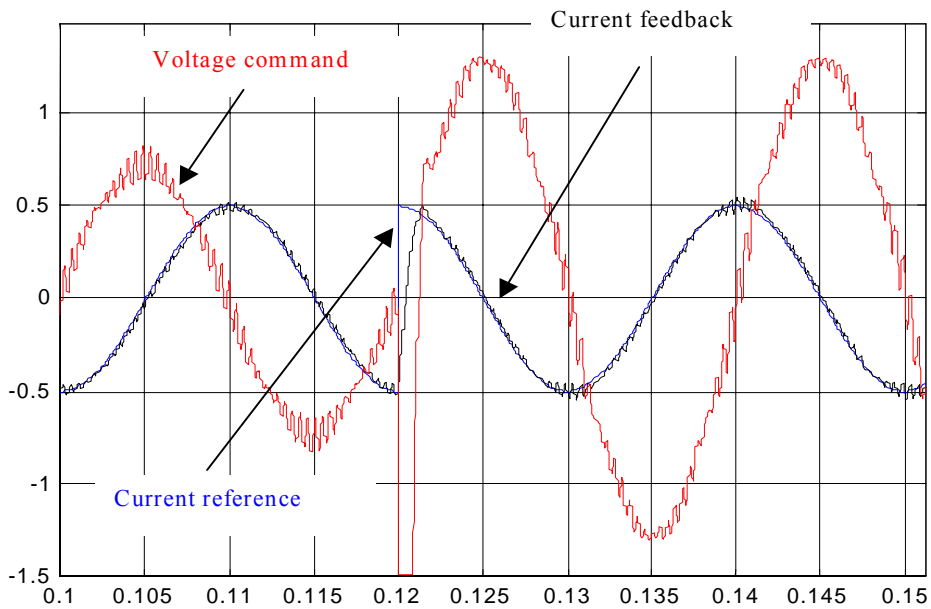

Figure B.23 Current regulation of STATCOM. Step change applied to the current reference causing the STATCOM output to swing from 50% inductive to 50% capacitive.

B2.4 Control Approach for Flicker Mitigation

This section presents a typical control scheme of STATCOM used for flicker mitigation. Several control blocks for understanding the functions required in the control schemes used are distinguished. The system for the control studies is presented.

Figure B.24 shows the single line diagram of a STATCOM scheme for flicker compensation.

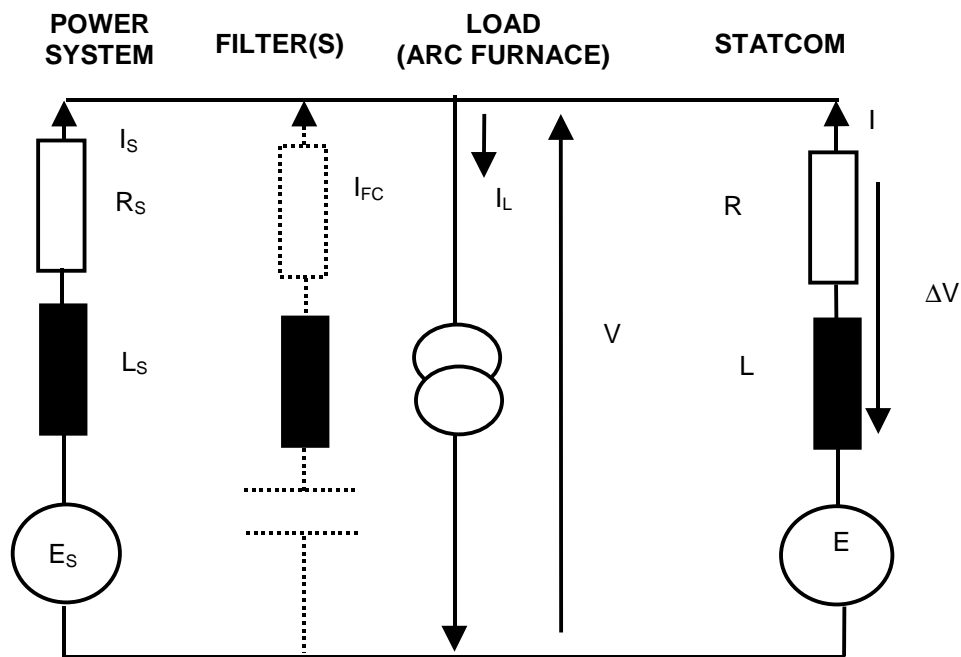

Figure B.24 Single line diagram of a STATCOM compensating a disturbing load.

In this diagram the power system is characterised by its no load voltage E_S and its short-circuit impedance (R_S and X_S); the optional filter capacitor banks (or fixed capacitive compensation) by its impedance and the current I_{FC} drawn from the power system; the disturbing load represented by the load current I_L , and the STATCOM represented by its internal source voltage E and its impedance given by R and X .

If there are of no fixed capacitors banks and/or filters or if for simplification the fixed capacitor and/or filter current is included in the load current, then the STATCOM current I is given by:

$$E_S - R_S \cdot I_S - L_S \cdot dI_S/dt = V = -R \cdot I - L \cdot dI/dt + E$$

Substituting $I_S = I_L - I$

we obtain $R_S \cdot I + L_S \cdot dI/dt + R \cdot I + L \cdot dI/dt = E - E_S + R_S \cdot I_L + L_S \cdot dI_L/dt$

This equation in the frequency domain becomes

$$I(s) = [(R_S + s * L_S) / (R_S + R + s * (L_S + L))] * I_L(s) + [(E(s) - E_S(s)) / (R_S + R + s * (L_S + L))] \quad (\text{Eqn B.10})$$

We can also say that;

$$I(s) = [(R_S + s * L_S) / (R + s * L)] * I_S(s) + [(E(s) - E_S(s)) / (R + s * L)]$$

And with $I = I_L - I_S$ this equation becomes

$$R_S * I_S + L_S * dI_S/dt + R * I_S + L * dI_S/dt = E_S - E + R * I_L + L * dI_L/dt$$

$$I_S(s) = [(R + s * L) / (R_S + R + s * (L_S + L))] * I_L(s) + [(E_S(s) - E(s)) / (R_S + R + s * (L_S + L))] \quad (\text{Eqn B.11})$$

The controls of the STATCOM act on the output voltage E of the STATCOM.

The current vectors I , I_L , and I_S in polar form can be expressed as

$$\begin{aligned} \mathbf{I} &= I_P + jI_Q \\ \mathbf{I}_L &= I_{LP} + jI_{LQ} \\ \mathbf{I}_S &= I_{SP} + jI_{SQ} \end{aligned}$$

In accordance with the equation B.10, a possible method of compensation could be achieved by applying a reference current signal $I_{ref} = -I_{LQ}$, the reactive component of the load current, to the STATCOM controller. Thus, the reactive current of the disturbing load is compensated by the action of the STATCOM control on the STATCOM current. This method is described above, with $R_t = R + R_S$ and $L_t = L + L_S$. In the transfer function block diagram shown in Figure B.25 where G(s) represents the corrector i.e., a gain term.

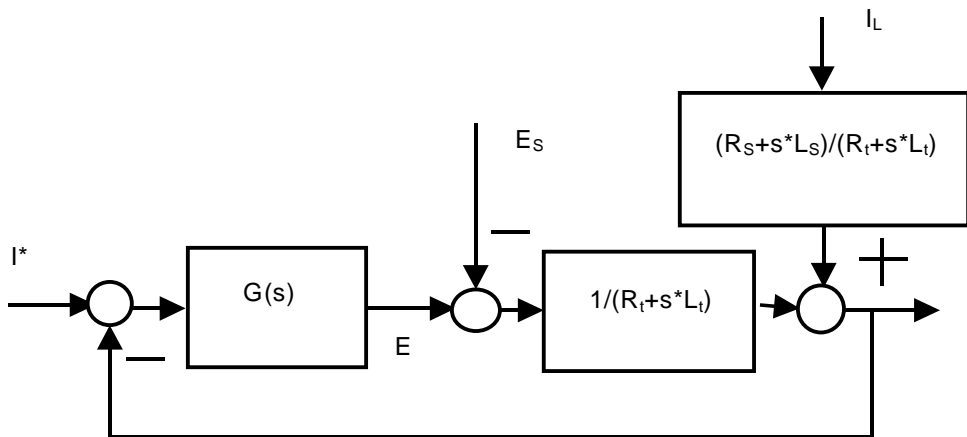

Figure B.25 Flicker control of STATCOM by “STATCOM Current” regulation. I^* equal to $I_{ref} = -I_{LQ}$.

According to equation equation B.11, the second compensation approach attempts to regulate the active component of the line current I_S . That is to say $I_{ref} = I_{SP}$ giving $I = -I_{LQ}$. This

approach is equivalent to the first in that although different signals and transfer functions are used in the STATCOM control system the same net result is achieved. The corresponding transfer function block diagram for this method of control is shown in Figure B.26.

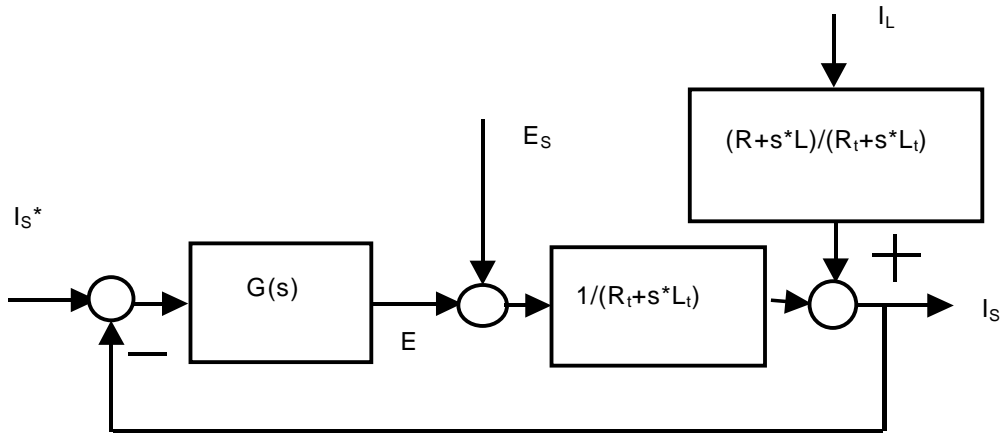

Figure B.26 Flicker control by of STATCOM by “Line Current” regulation $I_{ref} = I_{SP} = I_S^*$.

The transfer function $G(s)$ in both control methods represents the gain of the current regulator.

The “STATCOM Current” regulation method is preferred in practice for the following reasons:

- There is no risk of control system instability.
- The anti-saturation system for flicker priority in case of limitation of STATCOM capability is easier to do. The anti-saturation system allows to privilege the flicker mitigation versus power factor control in case of rating limitation of STATCOM capability.
- The control is exactly the same whether a filter or a fixed capacitor is installed or not.
- The regulation of the current seems easier to implement as shown in Figure B.27. Then the corrector gives only the voltage drop in the connecting reactor and the control is not depending on varying network parameters, as short circuit capability.

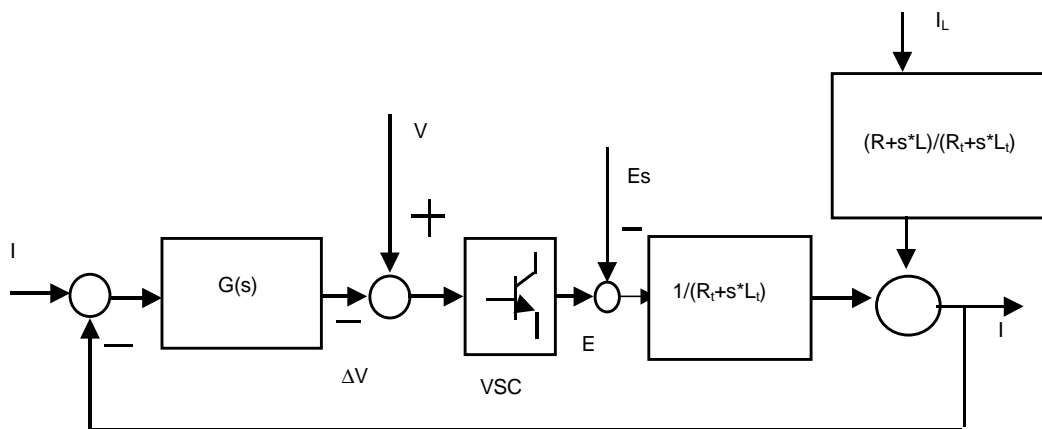

Figure B.27 Block diagram of the flicker control by “STATCOM Current” regulation scheme where the regulator produces only the correction term ΔV which is given by $\Delta V = R \cdot I + L \cdot dI/dt$.

The only advantage of the second method is that it uses the active and reactive part of the measured line current, and on the current reference calculation, as this current will be with close to unity power factor, and contain fewer harmonics where filters and/or fixed capacitors are included.

B2.5 Alternative Flicker Control Approach

The active and reactive current of the arc furnace could be expressed by several components. For instance the active and reactive current could be written as

$$I_d = I_{d\cong} + I_{d\approx} + I_{di} + I_{dh}$$

$$I_q = I_{q\cong} + I_{q\approx} + I_{qi} + I_{qh}$$

where:

$I_{d\cong}$, $I_{q\cong}$ represents the d.c. component and very low frequency components

$I_{d\approx}$, $I_{q\approx}$ represents the flicker components in frequency range from 0.5Hz to 35 Hz

I_{di} , I_{qi} represents the negative sequence components, and

I_{dh} , I_{qh} are the harmonic components.

As explained in Chapter 2, for flicker mitigation, three objectives of flicker compensation must be respected:

1. Balancing the arc furnace load current by making the negative sequence current equal to zero i.e., $I_{di} = 0$ and $I_{qi} = 0$
2. Compensating the reactive current $I_q^* = I_{q\cong} + I_{q\approx}$.
3. Compensating the active current fluctuation $I_{d\approx}$.

As it is explained at the introduction of this Appendix, compensating the active current fluctuation demands a big energy storage element. Therefore, in practice, the following three types of control are applicable.

Type 1:

The “Type 1” control carries out the basic control functions of:

1. Balancing the load $I_{di} = 0$ and $I_{qi} = 0$
2. Compensating the reactive current $I_q^* = I_{q\cong} + I_{q\approx}$.

This type of control assures $|V| = |E_s|$ by injecting some extra capacitive current into the system to compensate the voltage drop induced by the active current circulation. There is no compensation for the fluctuating active current component.

Type 2:

The “Type 2” control carries out the basic control functions of:

1. Balancing the load $I_{di} = 0$ and $I_{qi} = 0$
2. Compensating the reactive current $I_q^* = I_{q\cong} + I_{q\approx}$.
3. Partially compensating the active current fluctuation $I_{d\approx}$.

This permits the designer of control system to reach a compromise between the flicker reduction performance and the capital cost of the compensation.

Type 3:

The “Type 3” control carries out the basic control functions of:

1. Balancing the load $I_{di} = 0$ and $I_{qi} = 0$
2. Compensating the reactive current $I_q^* = I_{q\cong} + I_{q\approx}$.
3. Compensating the active current fluctuation $I_{d\approx}$ in full.

This could be achieved by STATCOM associated with an appropriately rated storage element or Superconducting Magnetic Energy Storage as shown in Figure B.28.

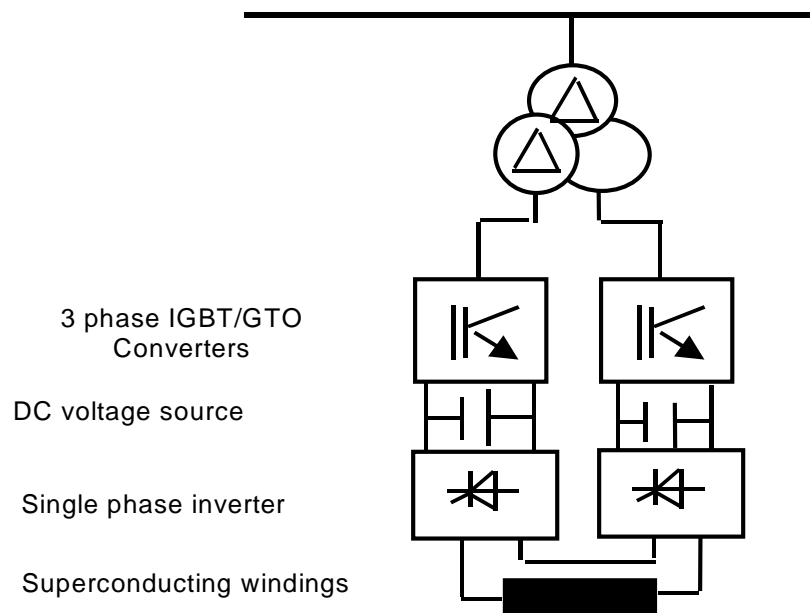

Figure B.28 STATCOM with superconducting magnetic energy storage.

B2.5.1 Implementation of Type 1 Control

The block diagram of this control is shown in Figure B.29. The reference signal I_q^* is calculated from the load active and reactive current measurements.

$$I_q^* = -(I_{q\cong} + I_{q\approx} + I_{qi} + I_{qh}) + R_S/X_S \cdot (I_{d\cong} + I_{d\approx}) + (I_{d\cong} + I_{d\approx})^2 \cdot S_{nom} / (2 \cdot S_{sc})$$

The reference signal I_d^* is derived from the d.c. voltage regulator and from the arc furnace load active current measurement:

$$I_d^* = -I_{di} - I_{dh} + I_d \cdot U_{dc}^*$$

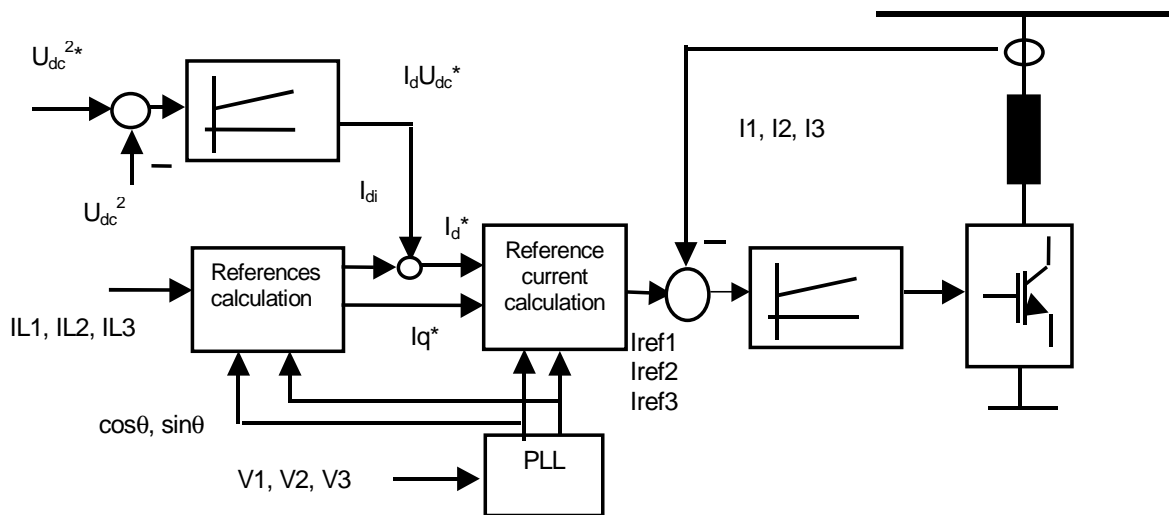

Figure B.29 Block diagram of Type 1Control.

B2.5.2 Implementation of Type 2Control

The block diagram of this control is shown in Figure B.30. The reference I_q^* is calculated from the load active and reactive current measurements.

$$I_q^* = -(I_{q\cong} + I_{q\approx} + I_{qi} + I_{qh}) + R_s/X_s \cdot (I_{d\cong}) + (I_{d\cong})^2 \cdot S_{nom} / (2 \cdot S_{sc})$$

The reference signal I_d^* is derived from the d.c. voltage regulator and from the arc furnace load active current measurement:

$$I_d^* = -I_{di} - I_{dh} + I_d \cdot U_{dc}^*$$

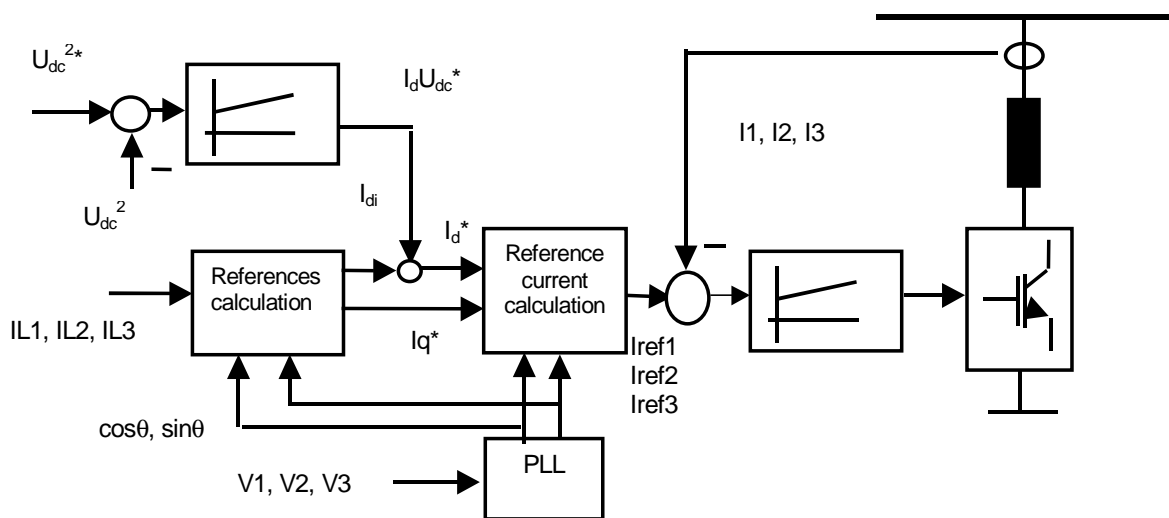

Figure B.30 Block diagram of Type 2Control.

The diagram principle for type 1 and 2 are the same as we can see in pictures B.29 and B.30. The difference are in the specific treatment (specific filtering) of the demodulated currents in References Calculation Block.

B2.5.3 Implementation of Type 3Control

The block diagram of this control is shown in Figure B.31. The reference I_q^* is calculated from the load active and reactive current measurements.

$$I_q^* = -(I_{q\cong} + I_{q\approx} + I_{qi} + I_{qh}) + R_s/X_s * (I_{d\cong}) + (I_{d\cong})^2 * S_{nom} / (2 * S_{sc})$$

The reference signal I_d^* is derived from the d.c. voltage regulator and from the arc furnace load active current measurement:

$$I_d^* = -(I_{d\cong} + I_{d\approx} + I_{di} + I_{dh}) + I_{dUdc}^*$$

The d.c. voltage regulator of the STATCOM ensures that the d.c. component of active current $I_{d\cong}$ is supplied by the network to the arc furnace load. In another term, I_{dUdc}^* will extract the component $-I_{d\cong}$ from the references I_d^* . Then, the STATCOM will compensate all the arc furnace load current except the d.c. component of the active current $I_{d\cong}$. This is why the control block diagram becomes like that presented in Figure B.31 using the “STATCOM current” control approach. Figures B.32 and B.33 show the same scheme with the same principle using “line current” control approach.

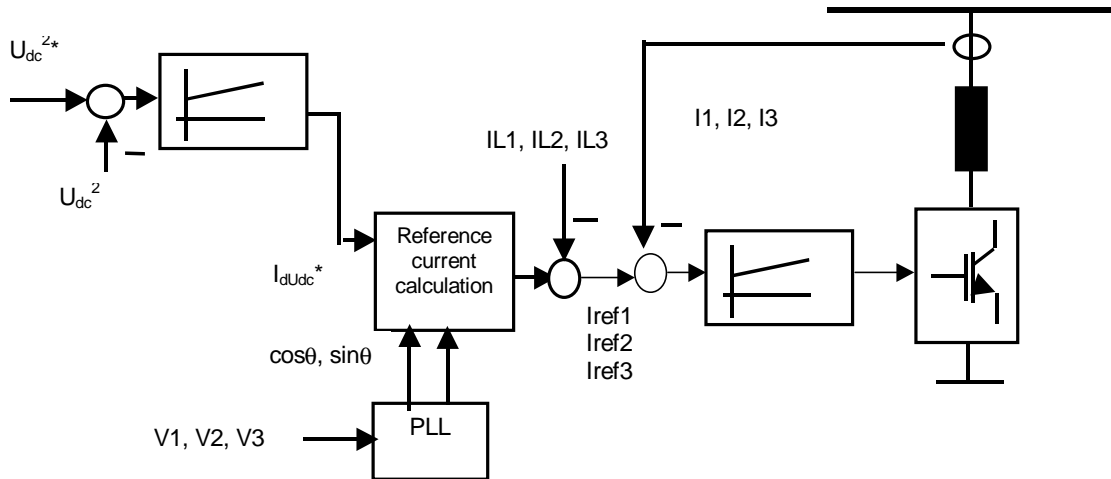

Figure B.31 Principle of Control type 3 with STATCOM current approach.

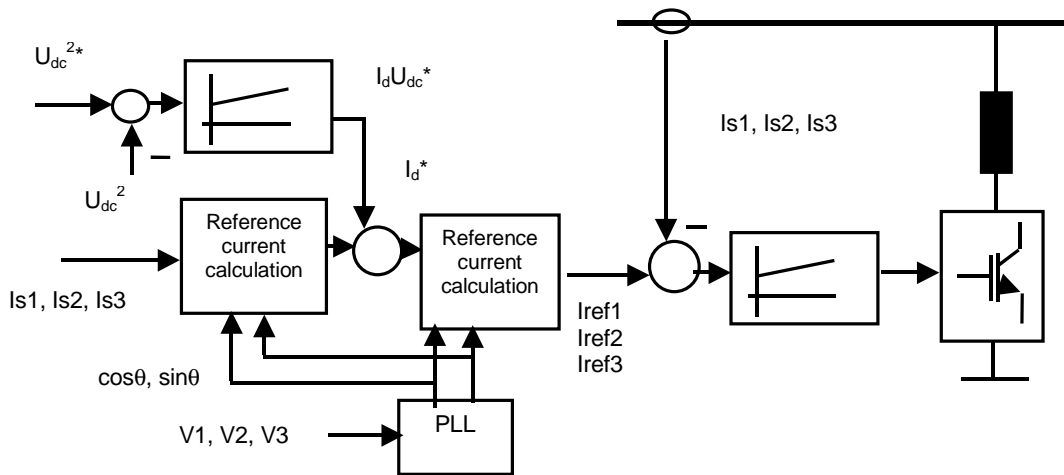

Figure B.32 Block diagram of Type 3 Control with “Line current” approach # 1.

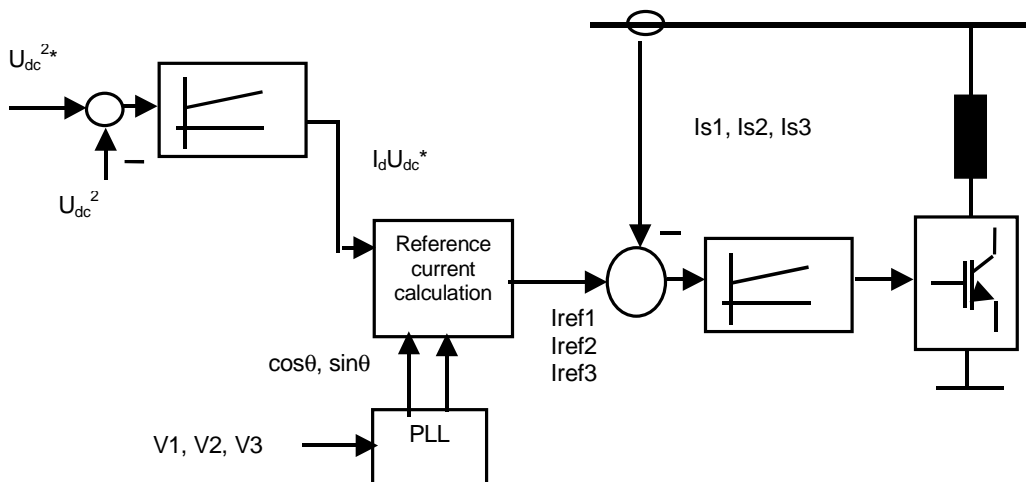

Figure B.33 Block diagram of Type 3 Control with “Line current” approach # 2.

This latter control scheme is equivalent to the previous ones by the fact the active power delivered by the power system must be equal to the active power consumed by the load. In fact if we write,

$$P_S = P + P_{load},$$

where

P_S represents the active power delivered by the power system

P represents the active power consumed or delivered by the STATCOM

P_{load} represents the active power consumed by the load.

When P_S is lower than P_{load} , then STATCOM delivers active power to the load. When P_S is greater than P_{load} , then STATCOM consumes active power. This means that in these cases, the d.c. voltage is varying.

The relationship between the d.c. voltage and the active power absorbed by the capacitors is given by the equation:

$$P_c = \frac{1}{2} * C * dU_{dc}^2 / dt$$

Figure B.34 illustrates the d.c. voltage regulation principle

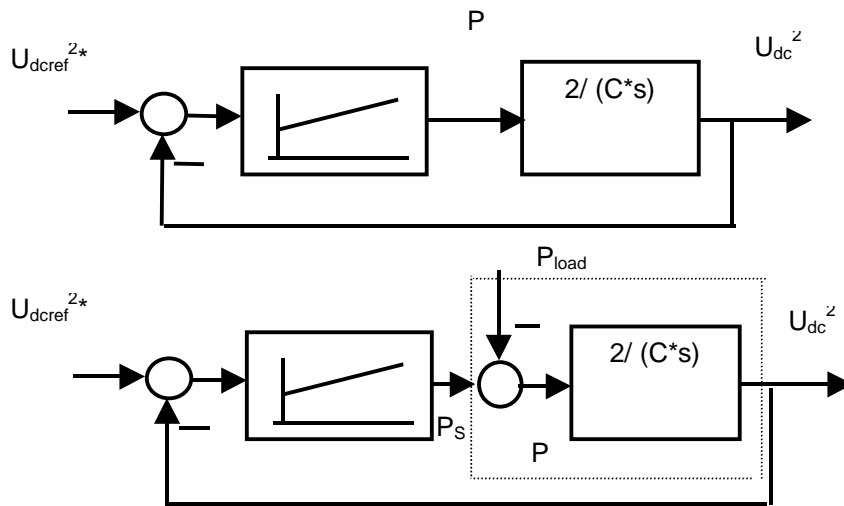

Figure B.34 The principle of d.c. voltage regulation.

All these control principles can be implemented by the vector control method and in derived active filtering control method as well. However, the control of STATCOM for flicker mitigation can be most easily achieved by controlling directly the currents in the stationary reference frame (as in active filtering control).

For example, Figure B.35 shows the block diagram of a control scheme which lends itself for the implementation with all types of control principles as well as the derived active filtering approach: The adjustment of the filters permits the implementation of type 1, type 2, or type 3 control.

Figure B.36 shows the block diagram of a control scheme available for the control in type 1, in derived active filtering method with current regulation in the stationary frame. However, this scheme does not permit harmonic compensation.

For all the control schemes the calculation of the positive sequence of the current is carried out using:

$$\begin{bmatrix} Id \\ Iq \end{bmatrix} = \begin{bmatrix} \cos \theta & \sin \theta \\ -\sin \theta & \cos \theta \end{bmatrix} * \begin{bmatrix} I\alpha \\ I\beta \end{bmatrix}$$

and the negative sequence current using:

$$\begin{bmatrix} Idi \\ Iqi \end{bmatrix} = \begin{bmatrix} \cos \theta & -\sin \theta \\ -\sin \theta & -\cos \theta \end{bmatrix} * \begin{bmatrix} I\alpha \\ I\beta \end{bmatrix}$$

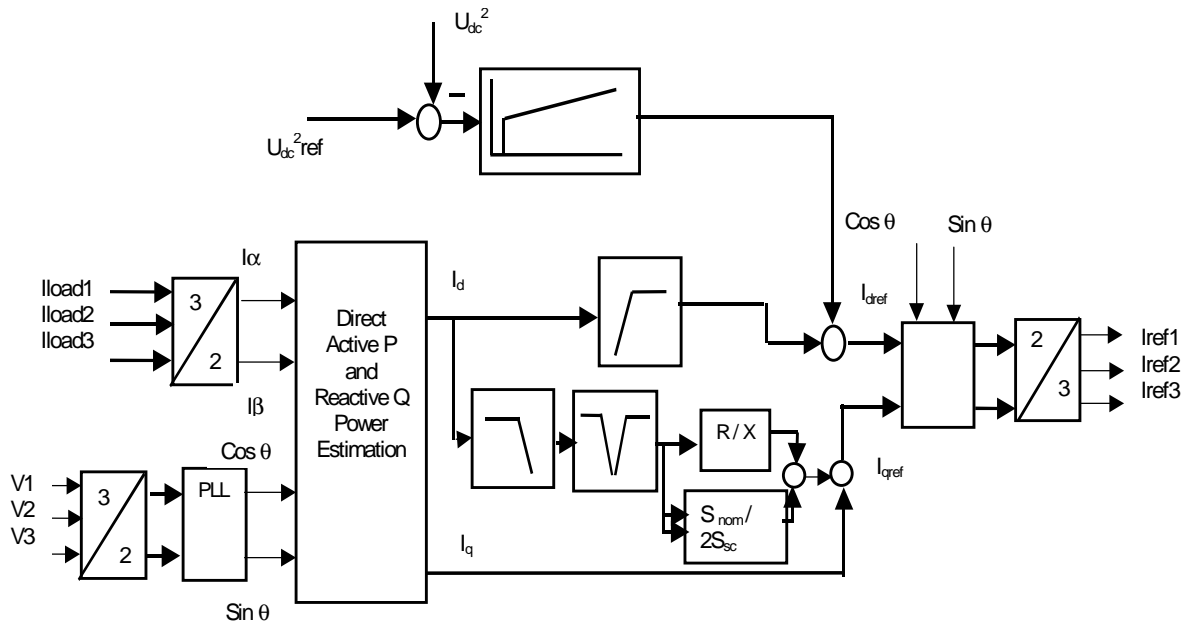

Figure B.35 Block diagram of the control scheme for implementation with Type 1, 2 or 3 controls in the derived active filtering approach.

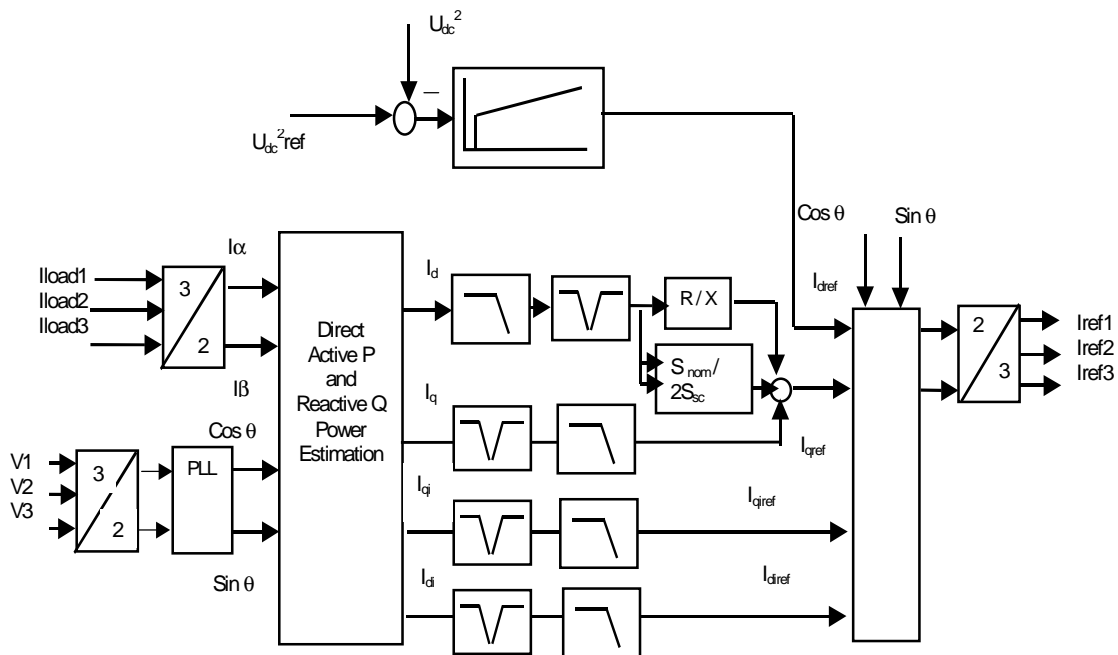

Figure B.36 Block diagram for the Type 1 control scheme in derived active filtering approach.

The scheme presented Figure B.36 is equivalent to the scheme presented in Figure B.35 except for the active filtering aspect, whereas the scheme presented Figure B.35 is able to compensate flicker and harmonics while the scheme in Figure B.36 is not able to compensate the harmonics. This is the reason why the control scheme presented in Figure B.35 will be preferred in practice but it will require the choice of a different rating for the STATCOM, as it includes the active filtering aspect. The harmonic control aspect is presented in Chapter 4.

B.3 SIMULATION RESULTS

A complete installation including Electric Arc furnace, network and STATCOM with Flicker control as presented in Figure B.35 was simulated. Figure B.37 shows the complete installation as implemented in Matlab Simulink software.

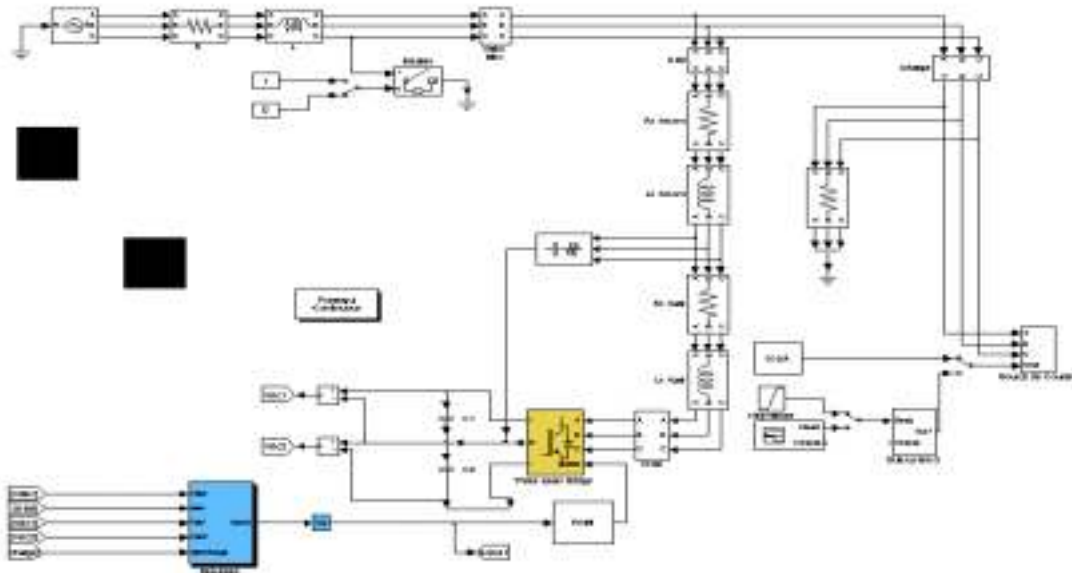

Figure B.37 Simulation of EAF installation in Matlab Simulink software.

Figures B.38, B.39 and B.40 present the flicker reduction in phases a, b and c obtained in this simulation.

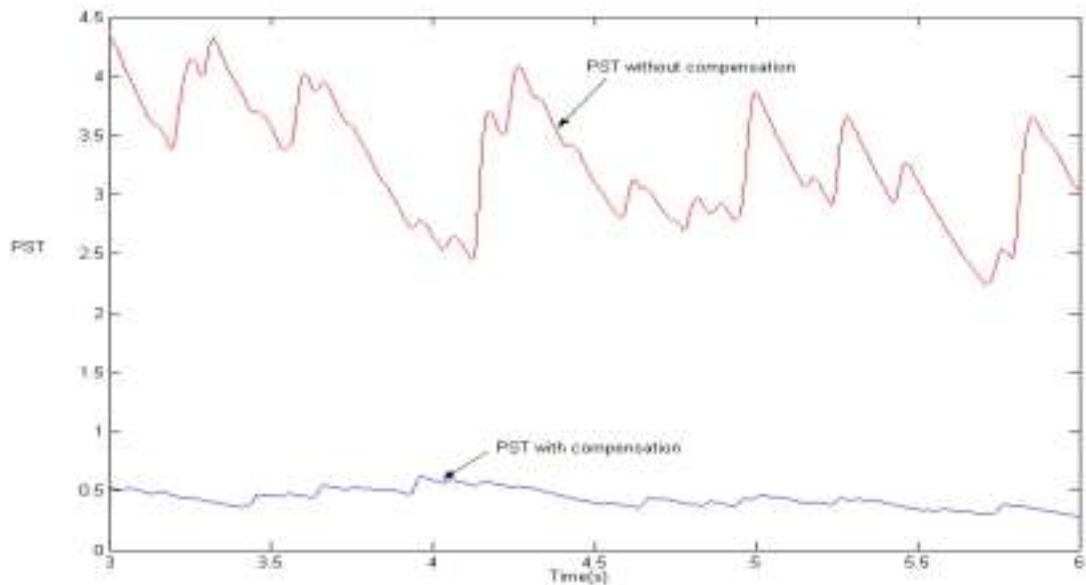

Figure B.38 PST without and with compensation in phase a.

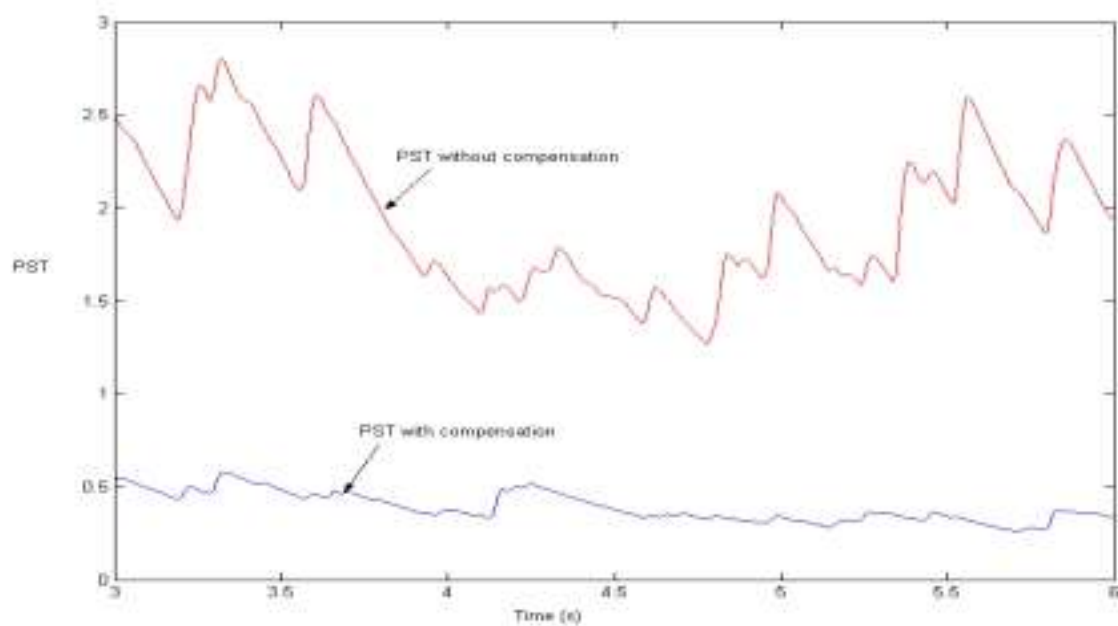

Figure B.39 PST without and with compensation in phase b.

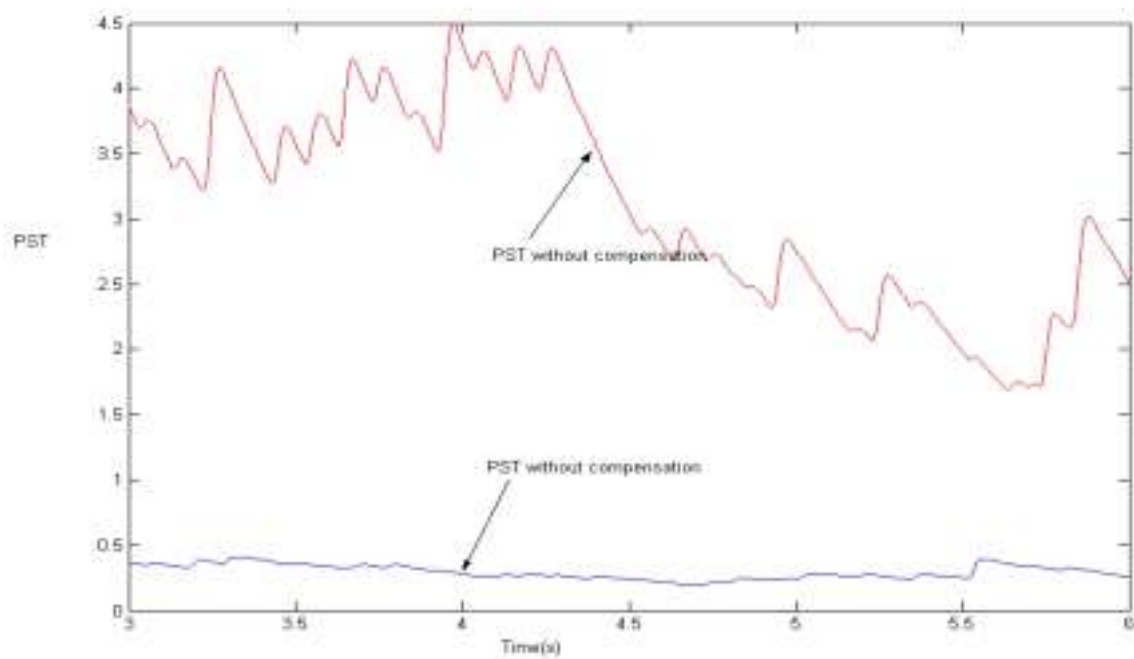
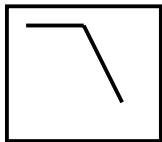

Figure B.40 PST without and with compensation in phase c.

B.4 References

- [B-1] Erinmez, I. A.; Foss, A.: “Static Synchronous Compensator (STATCOM)”, Technical Brochure No 144 of Cigré Working Group 14.19, 1999.
- [B-2] Depenbrock, M.: “Kompensation schnell veränderlicher Blindströme”, etz-a Bd. 98 (1977) H. 6.
- [B-3] Klinger, G.: Steuer- und Regeleinrichtung einer selbstgeführten Kompensations-Stromrichterschaltung”, etz-a Bd. 98(1977), H. 6.
- [B-4] Lê, T.-N.: Kompensation schnell veränderlicher Blindströme eines Drehstromverbrauchers”, etzArchiv Bd. 11 (1998) H. 8.
- [B-5] Larsson, T.: “Voltage Source Converters for Mitigation of Flicker Caused by Arc Furnaces”, Dissertation at School of Electrical Engineering and Information Technology (KTH) at University of Stockholm, ISBN 91-7170-274-1, 1998.
- [B-6] Paserba, J.; Reed, G.; Takeda, M.; Aritsuka, T.: “FACTS and Custom Power Equipment for the Enhancement of Power Transmission System Performance and Power Quality”. VII SEPOPE, Curitiba, Brasil, 21.-26. 5. 2000.
- [B-7] de Preville, G.: “Flicker mitigation, a STATCOM approach” Ganz European Power Electronics EPE2001
- [B-8] de Préville,G.:”Simulation de convertisseur multiniveaux, application à un STATCOM” Montpellier Electronique de Puissance du Futur EPF 2002.

Definition of elementary control blocks presented in the diagrams of this appendix are shown below.



Low band pass filter Block

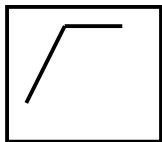

High band pass filter Block

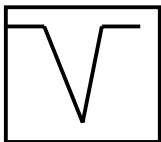

Notch filter Block

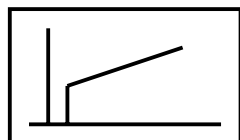
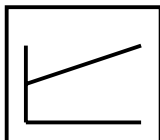

Corrector Block

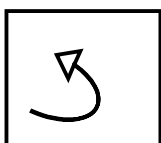

Rotating Frame Block

Appendix C BRIEF DESCRIPTION OF THE SCHWABE FLICKER METER EXTENSIVELY USED IN THE USA

The following description is taken directly from the description of the meter provided by William Schwabe, the designer and manufacturer of the meter.

“Each of the three inputs is measured independently by isolated modules. For each module the line voltage is resistively divided down to A/D levels and then digitized by a 16-bit converter. Two input ranges for voltages up to 240 volts RMS are software selected in supervisory mode. The sampling frequency is sufficient to measure up to the 30th harmonic at 60 Hz with a 100% over-range capability. Internally 30 harmonics, both real and imaginary components, are calculated. The dominant harmonic is selected from this information. The total harmonic distortion is calculated as the square root of the sum of the squares of all the components.

For the flicker measurements, each input data point is squared and passed through a sharp low pass digital filter with a break point at 38 Hz. Any residual line frequency components at 120/100 Hz are removed. Further filtering results in a flicker band pass filter of 0.5 Hz to 38 Hz. Between 1 and 30 Hz this (“FLAT”) filter deviates from 100% response by less than 1% and typically under 0.3%. The output, or processed flicker signal, is then converted to an RMS value. Dominant flicker frequency, line frequency and harmonic frequency are continuously calculated and displayed.

Special Filters

Filters corresponding to UIE and IEEE curves are included in the UHP Flicker/Harmonic Analyzer Model II D. These filters are based on the inverse of the defined filter and 100% response at the center or most critical frequency. Actual limits for the selected filter are set in the supervisory mode. When selected in supervisory mode, the flicker signal from the “FLAT” filter is passed through the selected digital filter to achieve the specific frequency response. Additional, user-specified filters are optionally available and can be selected by software or controlled by digital inputs selection on the rear of the unit.”

Appendix D

NOMENCLEATURE, ABBREVIATIONS AND GLOSSARY

NOMENCLEATURE

Complex and three-phase quantities denoted in **bold**.

Scalar quantities denoted in *italics*.

C_S	Capacitance of d.c. capacitor
d	Converter modulation depth ($= E/v_{dc}$)
E	Converter source voltage (see representation of three-phase quantities below)
E_S	Infinite bus source voltage
FR_{SVC}	Flicker reduction factor of an arc furnace installation compensated by an SVC
FI	The Flicker Improvement Ratio of Compensator [$FI = P_{st\ without} / P_{st\ with} = 1 / FR$]
FR	The Flicker Reduction Factor of Compensator [$FR = P_{st\ with} / P_{st\ without} = 1 / FI$]
I	Current drawn by STATCOM (see representation of three-phase quantities below)
I_F	Current drawn by the arc furnace from the power system (or I_{AF})
I_{1F}	Positive sequence component of the current drawn by the arc furnace from the power system
I_{2F}	Negative sequence component of the current drawn by the arc furnace from the power system
I_{1Fq}	The reactive component of the positive sequence current drawn by the arc furnace from the power system
I_{Fa}	Phase A current drawn by the arc furnace from the power system
I_{1Fa}	Positive sequence component of Phase A current drawn by the arc furnace from the power system
I_{2Fa}	Negative sequence component of Phase A current drawn by the arc furnace from the power system
I_{Fmax}	Maximum current drawn by the arc furnace from the power system
I_{Fmin}	Minimum current drawn by the arc furnace from the power system
I_{REF}	Current demand to the converter control space vector ($= I_{P,REF} + jI_{Q,REF}$)
$I_{L,REF}$	Reactive current demand to the converter control ($= -I_{Q,REF}$)
$I_{P,REF}$	Real part of I_{REF}
$I_{Q,REF}$	Imaginary part of I_{REF}
i_{dc}	d.c. current into the dc capacitor
I_{Cmax}	Maximum steady-state capacitive current drawn by STATCOM
I_{Lmax}	Maximum steady-state inductive current drawn by STATCOM
I_L	Inductive current drawn by STATCOM ($= -I_Q$)
I_d, I_q	Two-phase current components following application of Clarke transformation to the three-phase currents
I_d, I_q	d and q axis components of I_d and I_q along a rotating phasor locked in phase with the positive sequence a.c. system voltage
K_D	Voltage control droop gain ($= I/X_{SL}$)
L	Inductance between system terminal bus and STATCOM source voltage
p_n	Converter pulse number
p	Instantaneous active power

P	Real part of S
P_F	Real power drawn by the arc furnace from the power system
Q_F	Reactive power drawn by the arc furnace from the power system
P_{lt}	IEC long term flicker severity indicator (derived from P_{st} values over a period related to the duty cycle of the disturbing load)
$P_{lt99\%}$	The value of the P_{lt} with a 99% probability not to be exceeded over the total measurement period
$P_{lt95\%}$	The value of the P_{lt} with a 95% probability not to be exceeded over the total measurement period
P_{st}	IEC short term flicker severity indicator (perceived flicker severity averaged over 10 minutes)
$P_{st95\%}$	The value of the P_{st} with a 95% probability not to be exceeded over the total measurement period
$P_{st99\%}$	The value of the P_{st} with a 99% probability not to be exceeded over the total measurement period
q	Instantaneous reactive power
Q_{REF}	Reactive power demand to the converter control
Q_{REG}	Reactive power control reference setting
Q	Imaginary part of S
$Q_{ratedSTATCOM}$	The rated reactive power of the STATCOM compensator at rated voltage
$Q_{ratedSVC}$	The rated reactive power of the SVC compensator at rated voltage
R	Real part of Z
r_{Aa}	Arc resistance of phase A
r_{Amax}	Maximum value of the phase A arc resistance
r_{Amin}	Minimum value of the phase A arc resistance
s	Laplace operator
S	Complex power ($=P+jQ$)
S_f	The power rating of the arc furnace
S_{max}	The maximum apparent power demand of the fluctuating load
$S_{ratedAF}$	The rating of the arc furnace
S_{sc}	Three-phase short circuit fault MVA infeed at PCC
S_{scf}	The short circuit power of the arc furnace at PCC
S_{scmax}	Maximum three-phase short circuit fault MVA infeed
S_{ccn}	The minimum fault level at the connection point to the power system
S_{ccf}	The fault level of arc furnace assuming infinite fault level of connection point
S_L	Complex load at system terminal bus for power factor control ($=P_L+jQ_L$)
U	Machine internal voltage phasor or voltage at a specific point
V	System terminal voltage (see representation of three-phase quantities below) or any voltage in volts
v_{dc}	dc capacitor voltage
V_{REF}	Power system control reference voltage
V_{pcc}	Voltage at the point of common coupling
V_T	Measured value of V
X_{SL}	Voltage control droop reactance
X	Imaginary part of Z
X_E	Equivalent reactance
X_T	Arc furnace transformer reactance

Y	Symbol used on its own to indicate “wye” connection pattern of transformer windings
W	Power in watts
Z	Phase impedance between system terminal bus and STATCOM source voltage ($Z = R + jX$)
Z_S	System impedance from system terminal bus ($= R_S + jX_S$)
α	Thyristor firing delay angle with respect to the a.c. voltage zero crossing instant
(α, β)	Two-phase currents reference frame
ε	Space-vector transformation reference angle
	Machine / transmission system power angle
	Phase of convertor source voltage in P-Q rotating reference frame (STATCOM power angle)
	Phase of system terminal voltage in r-i stationary reference frame
	Phase of convertor source voltage in r-i stationary reference frame
v	Harmonic order
	Load power factor angle ($= \tan^{-1}(Q_L/P_L)$)
ϕ	STATCOM power factor angle ($= \tan^{-1}(Q/P)$)
ω	System angular frequency
\ddot{A}	Symbol preceding another symbol to indicate incremental value e.g., $\ddot{A}V$ voltage, $\ddot{A}I$ current, $\ddot{A}P$ power etc.
Δ	Symbol used on its own to indicate “delta” connection pattern of transformer windings
ΔV_{10} :	Indicator for flicker severity used in Japan
ΔV_{fn} :	Magnitude of sinusoidal voltage component of frequency f_n which is obtained from Fourier Transform of the voltage
Ω	Resistance in ohms

Representation of Three-phase Quantities (**E**, **I**, **V**)

e_a	Instantaneous phase quantity
e_{ab}	Instantaneous line quantity
$e_{i,a}$	Instantaneous phase quantity (device input)
$e_{o,a}$	Instantaneous phase quantity (device output)
i_a, i_b, i_c	Instantaneous line currents
e_a	Phasor of fundamental component of phase quantity
e	Space-vector in r-i stationary reference frame ($= e_r + j e_i$)
E	Three-phase quantity (e_a, e_b, e_c)
<u>E</u>	Phasor of fundamental positive phase sequence (pps) component or space-vector in an arbitrary synchronous reference frame ($= E + j E$)
E	Phasor of fundamental positive phase sequence (pps) component or space-vector in P-Q synchronous reference frame ($= E_P + j E_Q$)
E	Magnitude of e , E or <u>E</u>
E_v	v-th order harmonic quantity magnitude
v_a, v_b, v_c	Line to neutral voltages
Note 1 : Phasor quantities have magnitudes equal to r.m.s. values.	
Note 2 : $P + jQ = \mathbf{V} \mathbf{I}^* = V (I_P + j I_Q)^* = V (I_P - j I_Q) = V (I_P + j I_L)$	

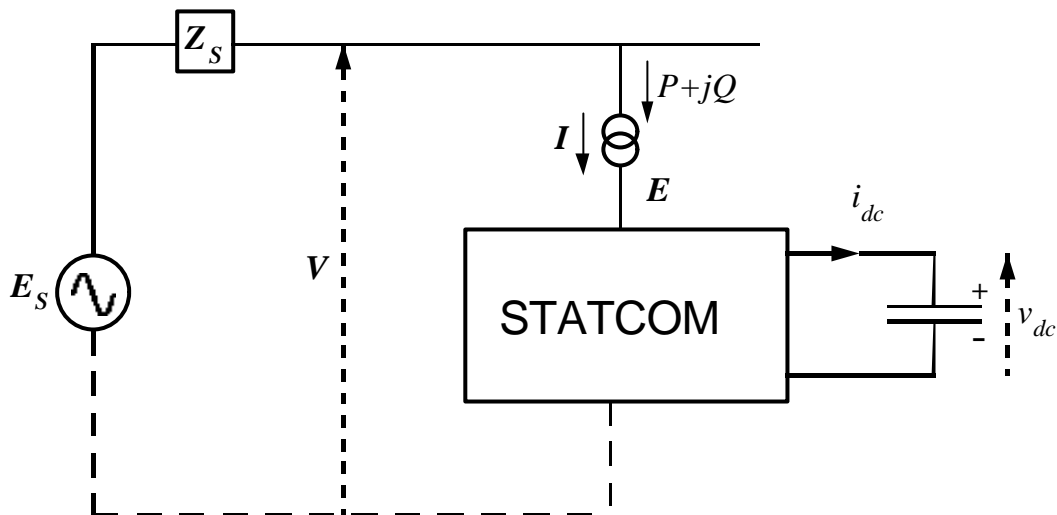

Voltage, Current and Power Sign Convention

ABBREVIATIONS

a.c.	Alternating current
ANSI	American National Standards Institute
CIGRE	Confrence International des Grands RJseaux l lectriques A Haute Tension
CIREN	Confrence International des RJseaux l lectriques A Distribution
CPF	Cumulative probability function
CSC	Controlled series compensation
CRPWM	Current-Reference Pulse Width Modulation
d.c.	Direct current
EHV	Extra-high voltage
EN	Euro Norm or European Community Standard
FACTS	Flexible a.c. Transmission System
FFT	Fast Fourier Transform
GCT	Gate Commutated Thyristor
GTO	Gate turn-off
HV	High voltage
HVDC	High voltage direct current
IEC	International Electrotechnical Commission
IEE	Institution of Electrical Engineers, UK
IEEE	Institute of Electrical and Electronics Engineers, USA
IGBT	Insulated Gate Bipolar Transistor
IGCT	Integrated Gate Commutated Thyristor
LV	Low voltage
MCT	MOS-Controlled Thyristor
MV	medium voltage
Mvar	Mega volt ampere reactive (unit of reactive power)
MW	Mega volt ampere real (unit of real power)
nps	Negative phase sequence

PAR	Phase angle regulator
PCC	Point of common coupling
POD	Power oscillation damping
pps	Positive phase sequence
PWM	Pulse width modulation
r.m.s.	Root mean square
r.s.s.	Root sum square
SCADA	Supervisory control and data acquisition
STATCOM	Static synchronous compensator
SVC	static var compensator
TCR	thyristor controlled reactor
THD	total harmonic distortion
TIF	telephone interference factor
TSC	thyristor switched capacitor
UIE	International Union of Electroheat (Union Internationale d'Electrothermie) or International Union for Electricity Applications
VA	Volt-Ampere
VSC	Voltage sourced converter
zps	Zero phase sequence

GLOSSARY

A Task Force of the IEEE FACTS Working Group developed a set of terms, which provide a common basis for discussing the various FACTS application related concepts described in this document [D-1]. These set of terms are included in this section together with the important terms related to flicker compensation applications discussed in this publication. In addition references [D-2, D-3, D-4, D-5] issued by UIE (International Union for Electricity Applications) and other UIE Publications contain further information and definitions on the subject matter contained in this report including flicker measurement techniques and international flicker meter specifications.

Battery Energy Storage System (BESS) – A chemical-based energy storage system using shunt connected, switching converters to supply or absorb energy to/from an ac system which can be adjusted rapidly.

FACTS – Alternating current transmission systems incorporating power electronic-based and other static controllers to enhance controllability and increase power transfer capability.

FACTS Controller – A power electronic-based system and other static equipment that provide control of one or more ac transmission system parameters.

Flexibility of Electric Power Transmission – The ability to accommodate change in the electric transmission system or operating conditions while maintaining sufficient steady-state and transient margins.

Interphase Power Controller (IPC) – A series-connected power controller consisting, in each phase, of inductive and capacitive branches subjected to separately phase-shifted voltages. The internal phase-shifts are implemented from interphase connections, giving each terminal a voltage-dependent current-source characteristic. The active power transfer is set by adjusting the phase-shifts and/or the impedances. The reactive power can be controlled independently of the active power. The set point of the characteristics can be modulated to meet the dynamic requirement of networks.

Static Synchronous Compensator (SSC or STATCOM) – A static synchronous generator operated without an external electric energy source as a shunt-connected static var compensator whose capacitive or inductive output current can be controlled independently of the ac system voltage. The STATCOM may include a transiently rated energy storage or energy absorbing device to enhance the dynamic behaviour of the power system by additional temporary real power (Watt) compensation.

Static Synchronous Condenser (STATCOM) – This term is deprecated in favour of the Static Synchronous Compensator (SSC or STATCOM).

Static Synchronous Generator (SSG) – A static, self-commutated switching power converter supplied from an appropriate electric energy source and operated to produce a set of adjustable multi-phase output voltages, which may be coupled to an ac power system for the purpose of exchanging independently controllable real and reactive power.

Static Synchronous Series Compensator (SSSC or S³C) – A static, synchronous generator operated without an external electric energy source as a series compensator whose output voltage is in quadrature with, and controllable independently of, the line current for the purpose of increasing or decreasing the overall reactive voltage drop across the line and thereby controlling the transmitted electric power. The S³C may include transiently rated energy storage or energy absorbing device to enhance the dynamic behaviour of the power system by additional temporary real power compensation to increase or decrease momentarily the overall real (resistive) voltage drop across the line.

Static Var Compensator (SVC) – A shunt-connected static var generator/absorber whose output is adjusted to exchange capacitive or inductive current so as to maintain or control specific parameters of the electrical power system (typically bus voltage).

Static Var Generator or Absorber (SVG) – A static electrical device, equipment, or system that is capable of drawing controlled capacitive and/or inductive current from an electrical power system and thereby generating or absorbing reactive power. Generally considered to consist of shunt-connected, thyristor-controlled reactor(s) and/or thyristor-switched capacitors.

Static Var System (SVS) – A combination of different static and mechanically-switched var compensators whose outputs are coordinated.

Super Conducting Magnetic Energy Storage (SMES) – A superconducting electromagnetic based energy storage system using shunt-connected switching converters to rapidly exchange energy with an ac system.

Thyristor Controlled Braking Resistor (TCBR) – A shunt-connected, thyristor-switched resistor, which is controlled to aid stabilization of a power system or to minimize power fluctuations on a generating unit.

Thyristor Controlled Phase Shifting Transformer (TCPST) – A phase-shifting transformer, adjusted by thyristor switches to provide a rapidly varying phase angle.

Thyristor Controlled Reactor (TCR) – A shunt-connected, thyristor-controlled inductor whose effective reactance is varied in a continuous manner by partial-conduction control of the thyristor valve.

Thyristor Controlled Series Capacitor (TCSC) – A capacitive reactance compensator which consists of series capacitor banks shunted by thyristor controlled reactor in order to provide a smoothly variable series capacitive reactance.

Thyristor Controlled Series Reactor (TCSR) – An inductive reactance compensator which consists of series reactor shunted by thyristor controlled reactor in order to provide a smoothly variable series inductive reactance.

Thyristor Controlled Voltage Limiter (TCVL) – A thyristor-switched metal-oxide varistor (MOV) to limit the voltage across the terminals during transient conditions.

Thyristor Switched Capacitor (TSC) – A shunt-connected, thyristor-switched capacitor whose effective reactance is varied in a stepwise manner by full- or zero-conduction operation of the thyristor valve.

Thyristor Switched Reactor (TSR) – A shunt-connected, thyristor-switched inductor whose effective reactance is varied in a stepwise manner by full- or zero-conduction operation of the thyristor valve.

Thyristor Switched Series Capacitor (TSSC) – A capacitive reactance compensator which consists of series capacitor banks shunted by a thyristor switched reactor to provide a step-wise control of series capacitive reactance.

Thyristor Switched Series Compensation – An impedance compensator which is applied in series on an ac transmission system to provide a step-wise control of series reactance.

Thyristor Switched Series Reactor (TSSR) – An inductive reactance compensator which consists of series reactor shunted by thyristor switched reactor in order to provide a step-wise control of series inductive reactance.

Unified Power Flow Controller (UPFC) – A combination of static synchronous compensator (STATCOM) and a static synchronous series compensator (S^3C) which are coupled via a common dc link, to allow bi-directional flow of real power between the series output terminals of the S^3C and shunt output terminals of the STATCOM, and are controlled to provide concurrent real and reactive series compensation without an external electric energy source. The UPFC, by means of angularly unconstrained series voltage injection, is able to control, concurrently or selectively, the transmission line voltage, impedance, an dangle or, alternatively, the real and reactive power flow in the line. The UPFC may also provide independently controllable shunt reactive compensation.

Var Compensating System (VCS) – A combination of different static and rotating var compensators whole output are coordinated.

The following definitions relating to the arc furnaces, fluctuating loads and their effects on power system supply quality are utilised throughout in this report.

Electric Arc Furnace – The electric arc furnace is an electrothermal system that uses the energy supplied by an electric arc to heat scrap metal placed in a vat. The arc created between the graphite electrodes of the furnace and the scrap metal melts the metal by the direct heating of the arc.

Fluctuating load – These are the types of non-linear loads connected to electric power systems causing rapid voltage fluctuations due to rapid variations in their active and reactive requirements dictated by the nature of the associated process or the process control requirements. Typical examples of such loads are resistance welding machines, rolling mills, arc furnaces, arc welders, saw/woodchip mills, rock crushers and large scale lasers.

Flicker – Flicker is the sensation experienced by the human visual system when subjected to changes occurring in the illumination intensity of light sources. Persistently and rapidly varying illumination due to the system voltage changes caused by rapidly varying loads such as arc furnaces can cause annoyance and adverse effects.

Power Supply Quality – This is a set of standards within which the power system is normally designed to operate where the limits for variations/deviations in voltage, frequency, voltage unbalance, repetitive voltage variations, flicker and harmonic distortion are clearly defined by the utility. The utility makes investments to maintain the supply quality standards and applies procedures to introduce measures or compensation equipment in cases when connecting certain types of loads which may impact on the supply quality and cause material damage and distress to other users of the supply system.

Flicker Reduction Factor (FR) – This is defined as the ratio of the reduction in flicker obtained before and after the installation of the compensation equipment expressed by the formula [$FR = P_{st\ with} / P_{st\ without} = 1 / FI$]. This factor could vary considerably for different modes of operation of the fluctuating load. It is therefore necessary to clearly define the operational conditions under which a particular reduction factor should be achieved.

Flicker Improvement Ratio (FI) – The inverse of the Flicker reduction Factor expressed by the formula [$FI = P_{st\ without} / P_{st\ with} = 1 / FR$]. In a similar manner to the Flicker Reduction Factor, this factor could vary considerably for different modes of operation of the fluctuating load. It is therefore necessary to clearly define the operational conditions under which a particular reduction factor should be achieved.

REFERENCES

- [D-1] IEEE Power Engineering Society and CIGRE – International Conference on Large High Voltage Electric Systems, “FACTS Overview”, IEEE Publication 95 TP 108, Piscataway, NJ, USA, 1995.
- [D-2] “Guide to Quality of Electrical Supply for Industrial Installations – Part 5: Flicker and Voltage Fluctuations”, UIE Power Quality WG 2, 1999.
- [D-3] WG Disturbances of UIE “Flicker Measurement and Evaluation, Second revised edition”, 1991.
- [D-4] “Guide to Quality of Electrical Supply for Industrial Installations – Part 5: Flicker and Voltage Fluctuations”, UIE Power Quality WG 2, 1999.
- [D-5] UIE Guide on “Flicker Measurement and Evaluation, 1992.

Copyright © 2002

Tout détenteur d'une publication CIGRE sur support papier ou électronique n'en possède qu'un droit d'usage. Sont interdites, sauf accord express du CIGRE, la reproduction totale ou partielle autre qu'à usage personnel et privé, et toute mise à disposition de tiers, dont la diffusion sur un réseau intranet ou un réseau d'entreprise.

Copyright © 2002

Ownership of a CIGRE publication, whether in paper form or on electronic support only infers right of use for personal purposes. Are prohibited, except if explicitly agreed by CIGRE, total or partial reproduction of the publication for use other than personal and transfer to a third party; hence circulation on any intranet or other company network is forbidden.