

**259**

# **FAILURE SURVEY ON CIRCUIT BREAKER CONTROL SYSTEMS**

**Working Group  
A3.12**

**October 2004**



# **Circuit Breaker Controls**

## **Failure Survey on Circuit Breaker Control Systems**

First Draft - January 2004

Last Changes 09.03.2004

CIGRÉ Working Group WG A3.12

### **Members:**

Harley Wilson, Mark Blundell, Jens Burger, Thomas Haas, Peter Högg, Antoni Hyczak, Hiroki Ito, Thierry Jung, Thomas Küng, Eva Pagán, Gunvantray Patel, Stanislaw Pokora, René Smeets

### **Copyright © 2004**

*"Ownership of a CIGRE publication, whether in paper form or on electronic support only infers right of use for personal purposes. Are prohibited, except if explicitly agreed by CIGRE, total or partial reproduction of the publication for use other than personal and transfer to a third party; hence circulation on any intranet or other company network is forbidden".*

### **Disclaimer notice**

*"CIGRE gives no warranty or assurance about the contents of this publication, nor does it accept any responsibility, as to the accuracy or exhaustiveness of the information. All implied warranties and conditions are excluded to the maximum extent permitted by law".*

## Introduction

The CIGRE Report of the Second International Enquiry on High Voltage Circuit Breaker Failures and Defects in Service was published in 1994 (Reference 1). This report, which considered SF<sub>6</sub> single pressure circuit breakers only, showed that approximately 25% of the major and minor failures of circuit breakers in service were caused by control circuit failures. This was the third highest cause of failure after operating mechanisms and leak tightness of SF<sub>6</sub> gas systems and associated monitoring. The First Enquiry on this subject was conducted in 1979 (Reference 2).

Since this observation is of concern to the operating utilities and manufacturers, CIGRE established Working Group A3.12 to further investigate the nature of control circuit failures and to make recommendations on how to improve the reliability and performance of circuit breaker control systems. Two of the objectives of this evaluation are to determine the nature of current failures in control systems and to ascertain whether the failures reported in 1994 remain as frequent with more modern technologies i.e. whether they were, in fact, related to older technologies. Working Group A3.12 was formed to focus solely on circuit breaker control system reliability. CIGRE Working Group A3.06 is conducting a more comprehensive evaluation of reliability for many different types of switchgear (not just circuit breakers) and all factors impacting reliability, not just control circuit reliability.

In order to achieve these objectives, CIGRE Working Group A3.12 conducted a limited survey concerning the frequency and nature of circuit breaker control system failures. To obtain this data in a timely manner, the survey was limited to selected utilities (2 – 3 per country which were easy to reach from the members of the working group) who were asked to report their experiences over the three-year period from 1998 through 2000. The results presented are based on data obtained from 27 utilities from 13 countries on 4 continents. This gives a worldwide overview of experience with different technologies. A total of 339 failures were reported in sufficient detail to be considered in the report. This report does not include any analysis of digital controls systems since very limited data was obtained in the initial survey. This will be a topic to be addressed in more detail in a follow-up evaluation. We thank all our interview partners for the useful cooperation.

A functional schematic diagram was developed to describe the basic functions that a circuit breaker must perform. This schematic allows for the differences in control systems due to the variations in the design of various circuit breakers (e.g. mechanisms, gas systems, degree of monitoring, as well as differences in the requirements of different countries). The results of the survey are summarized based on the functionalities described in this schematic.

This is the first time that a comprehensive overview of circuit breaker control has been published. Based on the results of the survey, recommendations are made for improving the performance of conventional control techniques and guidance is presented on aspects considered important for future, electronic technologies.

This is the first report of Working Group A3.12 and covers the initial survey results and key conclusions. A second report will be published in the future which will focus on possible corrective actions to improve circuit breaker control system reliability and to assess the possible impact of more advanced, electronic control systems.

## **Chapter 1**

### **Circuit Breaker Controls**

#### 1.1 Introduction to Circuit Breaker Controls

A circuit breaker is a device which opens or closes a high voltage circuit by opening or closing contacts which are driven by a mechanism. Circuit breakers are generally operated using solenoids, which release energy to the mechanical system to move the contacts. The energy required to operate the circuit breaker contacts is provided by various means (for example, spring, pneumatic pressure, hydraulic pressure, capacitor/motor, etc.) which are generally charged using motors or rectifiers. The circuit breaker is required to be capable of carrying, making and interrupting the normal and fault current. The breaker is operated by receiving an external command from an external relay or an operator which actuates the mechanism to change the position of the contacts. The external command is processed by the circuit breaker control circuit to provide the proper action to activate the circuit breaker. The circuit breaker control circuit is the electrical system required to ensure that the circuit breaker responds correctly, safely & reliably to external commands. This includes operating facilities such as operating coils as well as monitoring facilities such as condition and position indication. The reliability of this control circuit is the subject of this study.

When an external operating command is sent to a circuit breaker, the circuit breaker control system is required to determine whether the circuit breaker is ready to perform the required operation. If so, the control system is responsible for implementing the required action. Conversely if the circuit breaker is not able to complete the requested operation, the control system must prevent (“block” or “lockout”) the requested operation. To achieve this the control circuit monitors several conditions, such as operating energy, gas density, and the open/close position of the circuit breaker, in order to determine the operational capability of the circuit breaker at any given instant. In addition, the control system is required to monitor critical parameters and provide an alarm to the operator if these are changing such that they may cause the circuit breaker not to function in the future. This alarm function allows the operator to take action in a timely manner and prevent the circuit breaker from being unable to perform its function; a condition which may arise if changes in key parameters go unnoticed and uncorrected. In summary, the control circuit is required to supervise the operating conditions of the circuit breaker, prevent operation if the circuit breaker is outside its operational capabilities, and execute operating commands when it is safe to do so.

Control circuits vary for a variety of reasons including specific requirements in different countries, specific operator or system requirements, the type of operating mechanism, control voltage, control time, redundancy of the system, etc. However, all control circuits can be identified as having two main functions, these being:

1. Control of the circuit breaker
2. Monitoring of the condition of the circuit breaker (including auxiliary circuits) in order to:
  - Ensure safe operation of the circuit breaker
  - Provide information on the status of the circuit breaker to the operator

#### 1.2 Control Circuit Functions

By reviewing typical control circuit schematics from a variety of suppliers, the various vendors from different countries participating in the Working Group, a common logic for circuit breaker control circuits has been identified. This logic is more or less consistent regardless of the details of the schemes and the components used. This logic has been translated into a block diagram showing the essential functions of the control circuit which is shown in Figure 1.1. This diagram is the basis for

the reliability study which will be described later in the report. The specific components of this “standard” control schematic are described below. This basic schematic is appropriate for both single pole or three pole (Independent Pole Operation or “IPO”) tripping and closing. The components are related to the numbers shown in the schematic in Figure 1.1.

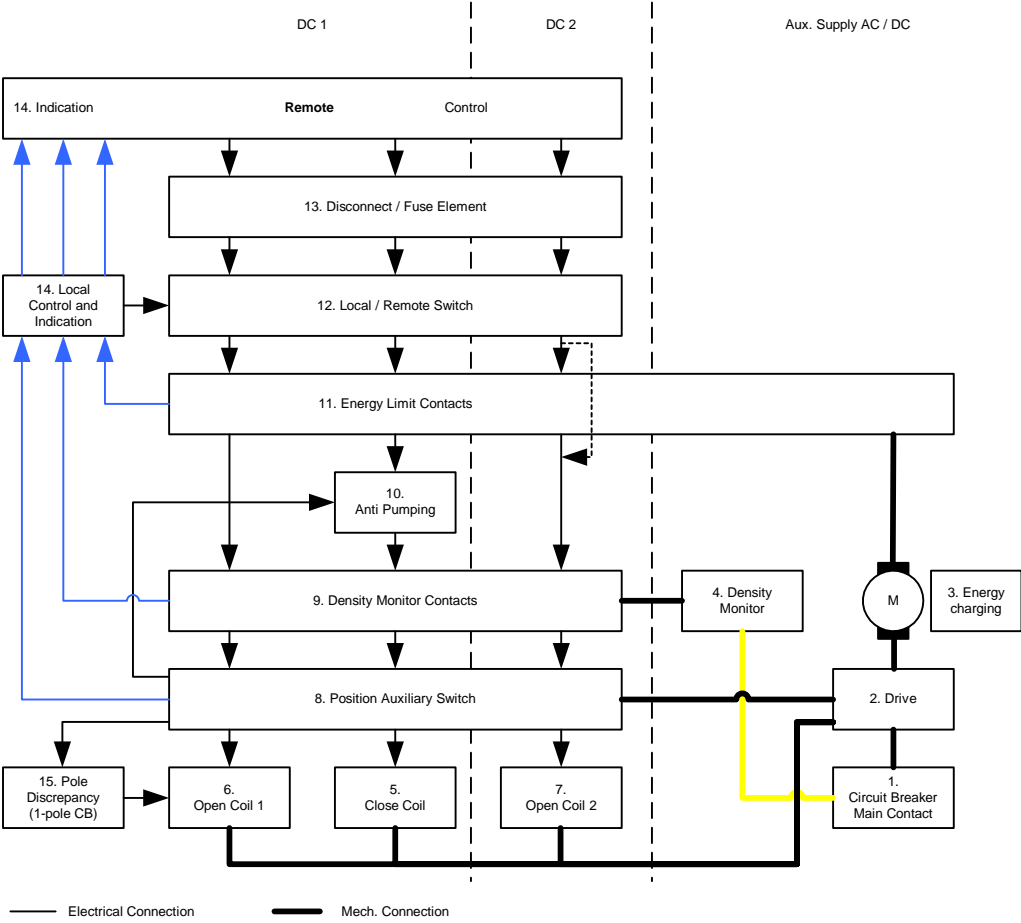

**Figure 1.1 – Generalized Circuit Breaker Control Schematic**

1. Circuit Breaker Main Contacts: The main contacts of the circuit breaker (not part of the control circuit).
2. Drive or operating mechanism: The mechanical device which releases the energy to move the main contacts (open and close) (not part of the control circuit).
3. Energy charging system: The device which provides energy to the operating mechanism in advance of operation to assure that the circuit breaker has adequate energy to close and/or open. In the case of hydraulic, spring, or pneumatic energy storage systems, this is an electric motor or a motor operated pump or compressor.
4. & 9. Density monitor and density monitor contacts: These devices provide the means for supervision of the insulation and/or arc extinguishing media; typically SF<sub>6</sub> in modern circuit breakers (in some cases, mixed gas technology is used to eliminate the need for heaters at low temperatures). Temperature compensated pressure switches are commonly used which operate auxiliary relays to prevent the tripping or closing of the circuit breaker if the SF<sub>6</sub> gas density in the enclosure falls below critical levels. There are two functions that are performed by these switches and contacts:

- To provide a warning or alarm in case of reduced SF<sub>6</sub> gas density in the enclosure before the lockout level is reached. This is an alarm only and provides time for the operator to correct the problem before the circuit breaker locks out and is not functional.
- To interlock or prohibit operation of the circuit breaker when the SF<sub>6</sub> gas density reaches a level (“lockout level”) where it will not operate safely. Typically the operator has the option of requiring the circuit breaker to automatically trip and lockout when this level is reached (“forced trip”) or having the circuit breaker lockout in the current position. The former option carries some safety risks.

5. Close coil: These are solenoid devices which are energised in the event of a valid closing signal being received by the circuit breaker. Energization releases the mechanism thereby closing the main contacts of the circuit breaker. Once the circuit breaker reaches the closed position, auxiliary switch contacts in the closing circuit open and de-energize the closing coils. Typically, there is only one closing coil in the control circuit.

6 & 7. Open coils: These are solenoid devices which are energized in the event of a valid opening signal being received by the circuit-breaker. Energization releases the mechanism thereby opening the main contacts of the circuit breaker. Once the circuit breaker reaches the open position auxiliary switch contacts in the trip coil circuits open and de-energize the trip coils. There are typically two trip coils that operate from independent power supplies. The operation of only one trip coil is sufficient to operate the circuit breaker. Two coils are provided in order to minimise the risk of a failure to trip.

8. Position auxiliary switch: These contacts, which are driven by the operation of the circuit breaker, are used to interrupt the current of the close and trip coils to de-energize them when the operation is complete. They are also used for indication and monitoring of the circuit breaker position and to interlock control & protection operations at the bay or station level to prevent an incorrect switching operation. These switches can be used for any function where the position of the circuit breaker is a required parameter.

10. Anti-Pumping: Anti pumping refers to the prevention of a re-closing operation in the situation where a previous close command is still applied to a circuit breaker that has been opened. This prevents the circuit breaker from repeatedly closing and opening. Typically the close command energizes an anti-pumping relay via an auxiliary switch contact (a Normally Open (NO) contact). One contact of the anti-pumping relay interrupts the circuit to the close coil. A second contact is used to latch or “seal in” the anti-pumping relay until the close command is removed from the circuit.

11. Energy limit contact: The energy limit contacts are set to operate when the stored energy in the mechanism is depleted either by operation or losses. Typically they start a motor in order to restore the energy of the mechanism to its normal operating level e.g. spring position, hydraulic/pneumatic pressure. For spring mechanisms recharging is typically after every close operation whilst other mechanism types may be able to perform several operations before recharging is required. Pneumatic & hydraulic systems have a switch which monitors the pressure and energizes a compressor when it falls below a critical level. When the energy level is restored, a switch opens, which stops the motor. The motor typically has protection against thermal overload and a time limit relay, which will stop the motor (or a motor operated pump or compressor) in the event of a malfunction. The switches or contacts monitoring the stored energy, therefore, perform the following functions:

- Lock out the close operation if the circuit breaker does not have enough energy to close and re-open safely.
- Lock out the open operation if the circuit breaker does not have enough energy to open safely. This is typical for hydraulic or pneumatic circuit breakers but not for spring operation where a successful closing charges the opening spring(s).
- Control (start and stop) the charging circuit of the energy storage device (e.g. spring).

12. Local/remote switch: This is a selector switch which allows the operator to interrupt remote control and only operate the circuit breaker locally. This is a safety feature to prevent remote operation of the circuit breaker while it is being serviced.

13. Disconnect/Fuse element: These devices are used to interrupt the power to the control system during maintenance work or during a fault to the control circuit. Disconnection is typically provided by knife switches or removable fuses/links which provide visual confirmation that the control circuit is open and which may be locked open to prevent unauthorised re-instatement. Where protection against short circuit is required, Mini Circuit Breakers (MCB) may be used as an alternative to simple fuses.

14. Local control and indication: This function provides an indication of the position of the circuit breaker and the status of the local/remote control facility. These indicators are for maintenance or emergency operations (depending on local safety rules).

15. Pole discrepancy / pole disagreement circuit: For Independent Pole Operation (IPO) circuit breakers (one mechanism for each phase); it is possible for one phase of the circuit breaker to not have the same position (open or close) as the other phases. This situation is called pole discrepancy or pole disagreement and can result in an unsymmetrical primary current. Auxiliary switch contacts in each phase are used to energize a time delay relay in the event that a pole discrepancy occurs. Assuming the discrepancy condition is persistent, after the preset time delay, an attempt will be made to trip all phases of the circuit breaker. In the event that the pole discrepancy was due to a failure to close of one pole, this trip is likely to succeed. However, if the initial discrepancy was due to a failure to open, the failed pole is unlikely to respond to subsequent opening commands and opening of other circuit breakers may be necessary. The preset time delay is normally between 1.5 to 5 seconds. The time depends on the specific grid conditions and how long the primary circuit could have operated asymmetrically (should be longer than 1 phase auto reclose time and shorter than the negative phase sequence protection of generation).

16. Heating: Space heaters are often provided in each of the operating mechanism and control housings to reduce condensation.

### 1.3 Overview of Control, Monitoring and other Functions

#### 1. Basic control functions directly related to control of the circuit breaker

As described above in Section 1.2, the control circuit is required to perform the following basic functions for the circuit breaker to operate safely.

- Charge the operating mechanism
- Verify that the circuit breaker is capable of performing its intended function (and block operation if it is not)
- Apply the close command
- Release the energy to move the main contacts
- Apply the open/trip command (1/3 phase, from control or protection)
- Trip the circuit breaker if it is not in the proper position (pole disagreement / discrepancy)
- Protect against repeated incorrect operation (Anti pumping)
- Control the environment of the drive (Anti condensation)
- Local / Remote switching
- Local power switching

#### 2. Monitoring functions directly related to control of the circuit breaker

In addition to the control functions listed above the control system will perform the following monitoring functions which are required for both supervision of the circuit breaker operation and information for the operator.

a) Frequently used:

- Stored energy status
- Position of local/remote selector switch
- Trip circuit supervision
- Insulating/extinguishing media status
- Position of the main contacts
- Pole discrepancy
- Thermal overload of the motor
- Count of circuit breaker operations

b) Seldom used currently but may be more frequently used with digital controls:

- Information about the travel curve of the circuit breaker
- Maximum running time of the recharging system
- Counter of system recharging (hydraulic, pneumatic)
- Monitoring of internal environment

3. Advanced Control Functions that are commonly mentioned within the circuit breaker control but which may be controlled at the bay level.

- Under voltage trip
- Auto-reclose
- Controlled Switching

This first report only addresses those functions described in 1. and 2.a) which relate directly to the circuit breaker operation.

#### 1.4 Specific Practices for Users and Manufacturers

Section 1.2 details the basic control and monitoring functions for the control circuits. However, it should be noted that there are many different practices that are used in various countries and by specific users and manufacturers. It is impractical to detail all variations but several of the most important differences are summarized below.

1. For ratings higher than 300kV, an additional circuit is required for redundancy except for cabinet heater, alarm contacts, spring charged motor, etc. Above 550kV, full duplicate control circuits are required in some countries. Duplicate control systems are required by some customers independent of rating.
2. At transmission voltages two voltage sources are generally used for the control circuit to provide redundancy. However, for lower voltages, due to cost reasons, one control voltage source is normally used. In any case, the practice is to use two trip circuits for high voltage breakers.
3. The close and trip coils are generally connected to the negative terminal of the supply voltage and disconnected from the positive terminal. This has an advantage of avoiding galvanic corrosion and deterioration of the coils.

4. The auxiliary switch pack generally provides additional contacts over and above those required for the control circuit. Six normally open (NO) and six normally closed (NC) contacts are generally available for other uses. Nevertheless, it is common for users to specify much higher numbers (as many as 16 NO + 16 NC) which are made available either directly or by using relay based contact multiplication.
5. The monitoring contacts (contacts of sensors like density monitor, spring charge monitor limit switch etc.) in a control circuit are generally used to energize an auxiliary relay. Typically these relays remain energized under normal working condition. This maximizes the reliability of the circuit since relay coil failure can be detected immediately and an alarm generated. A few users have reported using these relays in a normally de-energized mode such that they are only energized in the event of a change in state of the monitored parameter.
6. The control circuit is generally wired through 1.5mm<sup>2</sup> conductors however; some customers prefer 2.5mm<sup>2</sup> conductors.
7. It has been common practice to use lugs to terminate the wires on the equipment. Many termination options exist today and can be successfully used providing requirements for repeated disconnection/reconnection.
8. The drive charging motor is governed by a separate standard which does not relate specifically to high voltage products. The circuit breaker is governed by IEC62271-100 and IEC 60694. The dielectric test voltage for the auxiliary circuit in accordance with the circuit breaker standard is 2000 volts; however, the test voltage for the motor in accordance with the motor standard is 1500 volts. In addition, IEC 60694 defines 5kV impulse voltage withstand testing as a Type test. Lower values of 2,5kV for the impulse test and 1 kV for the power frequency test are permitted. However general practice is to bypass the motor (and other peripheral components such as lighting) during the dielectric test. This is in line with the IEC Standard.
9. Heaters are used to avoid condensation of moisture in humid conditions. For cold weather applications, additional heaters can be used to raise the internal ambient temperature to avoid malfunction of the components. Normally heaters are used which are rated to maintain the temperature without the use of thermostatic relays. However, thermostatic relays can be used if requested.
10. In some countries, no-fuse circuit- breakers (mini circuit-breakers (MCB's)) are used instead of the combination of a switch and a fuse. For example, no-fuse circuit breakers are applied for the protection of the motor circuit and the heater circuit. For most designs of spring operating mechanisms, a lockout switch for the stored energy of the close circuit is omitted since it is inherent in the design that a closing operation can only be initiated if the closing spring is completely charged. The surveillance circuit for the energy replenishment of spring operating mechanisms detects over-current and the operating time of a spring charged motor.

## Chapter 2 Questionnaire

The first and second CIGRE reports on failures and defects of high voltage circuit breakers (1, 2) concerned only one technology, i.e. SF<sub>6</sub> circuit breakers. The second survey was further limited to single pressure SF<sub>6</sub> circuit breakers. Since the percentage of major and minor failures caused by control circuits was high, the question of whether the problem was unique to SF<sub>6</sub> technology was raised. It was also noted that the pattern of failure rates appeared different for different types of operating mechanisms.

As a follow up activity from these reports, Working Group A3.12 conducted a limited survey to investigate the failures and defects of control circuits. In order to receive the most relevant information for the intended analysis e.g. which components are responsible for the failures and what the control circuit failure causes are, it was necessary to determine the most probable failure modes.

As members of WG A3.12 represent different Countries from Europe, Asia and North America, it was determined that the best way to gather the required data would be by each member conducting the survey "locally". In order to obtain the data in an expeditious manner, the survey was limited to cover the three years of 1998, 1999 and 2000. Every member of the Group was to interview three or more Utilities from their country or find somebody who could do the same work in the neighboring countries.

The questionnaire was tailored to the study objectives. The study objective was not to receive statistical data on failures and defects, but information on which failure modes, components and causes appear most frequently. The questionnaire was composed of two parts. The first part refers to the respondent and gives information about Country and Utility, date of completion, name of respondent, etc. The second part is the identification of the failure, identification of the circuit breaker, its history, application, environmental and system conditions, failure cause, and its criticality as well as the failed component and cause of failure. A copy of the questionnaire is attached in Table 2.1.

The failures were assigned to one of four major groups by the participating utility. These are summarized below:

- N - Major error no operation (failure to operate on command)
- U - Major error unintended operation (spurious operation)
- S - Minor error detected by self supervision (or continuous monitoring)
- I - Minor error detected by inspection

The categories refer to the component of control circuit which is responsible for a failure and the direct and indirect causes of the failure.

## Part I. Identification of the respondent

<b>Respondent information</b>	
Short Name	
Country	
Utility Name	
Address	
Contact Person Name	
Telephone	
Fax	
E-mail	
Date of questionnaire completed	
Name of Interviewer	

## Part II. Failure questionnaire

Respondent identification
---------------------------

Identification of incident	
General failure description	
Year of failure	
Environmental circumstances and operation conditions	

Identification of CB				
- Breaker technology	SF <sub>6</sub>	Air blast	Oil	Other
- Operating mechanism	Spring	Hydraulic	Pneumatic	Other
- Ambient service condition	Indoor	Outdoor		
- Rated voltage		KV		
- Year of manufacturing				
- Years of service				
- Years of service since last maintenance				
- Number of operations				
- Type of application	Line	Transformer	Capacitor	Reactor

Detailed failure description		
Classification	X	Comment ( e.g. reasons)
<b>Did not operate on command (major failure)</b>		
- Defect of the coil		
- Defect of current limiting resistor		
- Non continuity of circuit		
- Bad joint in wires		
- Disrupted wires		
- Defect of the auxiliary switch		
- bad contacting		
- no switching (mechanical problem)		
- Defect of an auxiliary relay		
- Defect of a limit switch		
- Defect of contact manometer		

- Defect of stored energy monitoring devices		
- Defect of density monitoring device		
- Incorrect blocking (lockout)		
- Defect of other supervision devices		
- Others		
<b>Spurious (unintended) operation (major failure)</b>		
- Earth fault in the close / opening circuits		
- Defect of the auxiliary switch		
- bad contacting		
- no switching (mechanical problem)		
- Defect of an auxiliary relay		
- Defect of density monitoring devices		
- Defect of other supervision devices		
- Others		
<b>Minor failures (detected by self supervision)</b>		
- Trip circuit supervision		
- Others		
<b>Minor failures (detected by inspection)</b>		
- Loose joints		
- broken wires		
- corrosion		
- animals		
- others		

**Table 2.1**

## Chapter 3 Results of the enquiry

### 3.1 Data summary

Replies were received from 27 utilities, covering 13 countries from all major areas of the world. 339 of the failure reports were considered sufficiently complete to support the Working Group's study. The participating countries were USA, Germany, Netherlands, Rumania, Switzerland, Australia, Poland, New Zealand, Spain, The Czech Republic, India, and Japan. Although this result may seem small compared to other similar studies (such as WG 13.06 for the second international enquiry on high-voltage circuit breaker failure or WG 13.08 for its study on operational stresses in service), the scope of this study was a subset of all circuit breaker failures, which requires more detailed knowledge and analysis of the failure causes. Consequently, this data was much more difficult to gather.

More than half of the replies were not fully usable because the cause of the failure was not known in sufficient detail. One could surmise that, in some cases, outsourced maintenance might involve less detailed knowledge about causes of failure. It should be noted that approximately 50 % of all the replies were supplied by 4 utilities from 2 countries. One country contributed approximately 35 % of the answers. The breakdown of the data by region is summarized in Figure 3.1.

The overall distribution of the data is summarized below as a function of several key variables (geographic region, application, voltage class, and technology). The analysis of the data is then summarized.

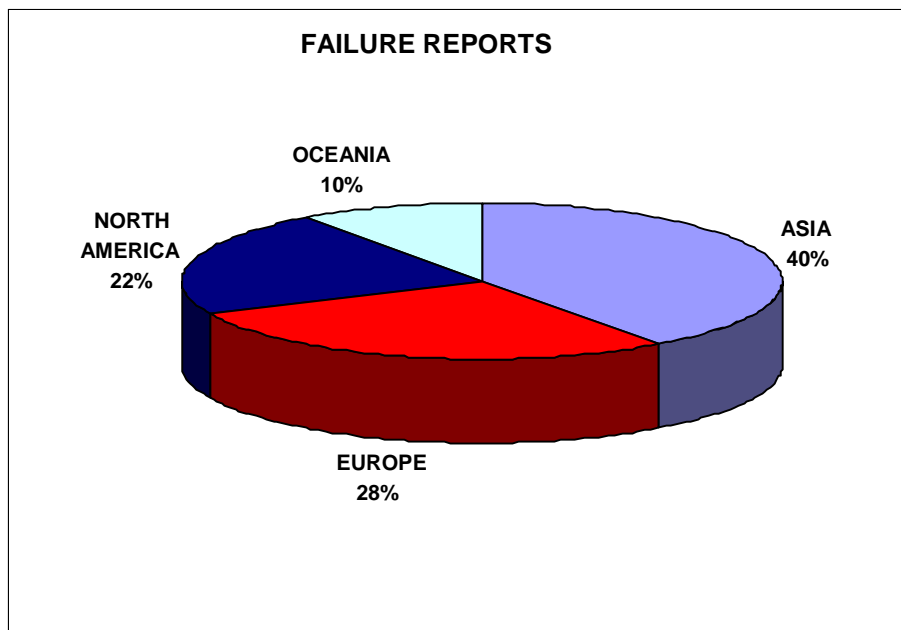

**Figure 3.1: Failure reports vs. geographical origin**

Note: Asian data is largely dominated by Japanese input

#### 3.1.1 Distribution by Geographic Region

The distribution of data between all major regions of the world is somewhat unbalanced by the absence of any input from Africa and a large amount of data coming from Asia (see fig. 3.1). This situation is in line with the distribution observed during previous reliability studies, with the exception that the larger amount of data in this study came from a different region of the world than in previous inquiries (i.e. Asia vs. Europe).

There does not seem to be any significant difference between countries and regions as far as the distribution of major failures are concerned. However, some differences appear for minor failures detected by maintenance operations. In Japan some utilities maintained detailed records as a result of frequent inspections which resulted in many minor failures. Other regions were more dominated by major failures.

3.1.2 Distribution by Application

Two categories of circuit breaker application represent the service condition of the majority of the reported failures: 73 % of the responses relate to line breakers, and 18 % to transformer breakers

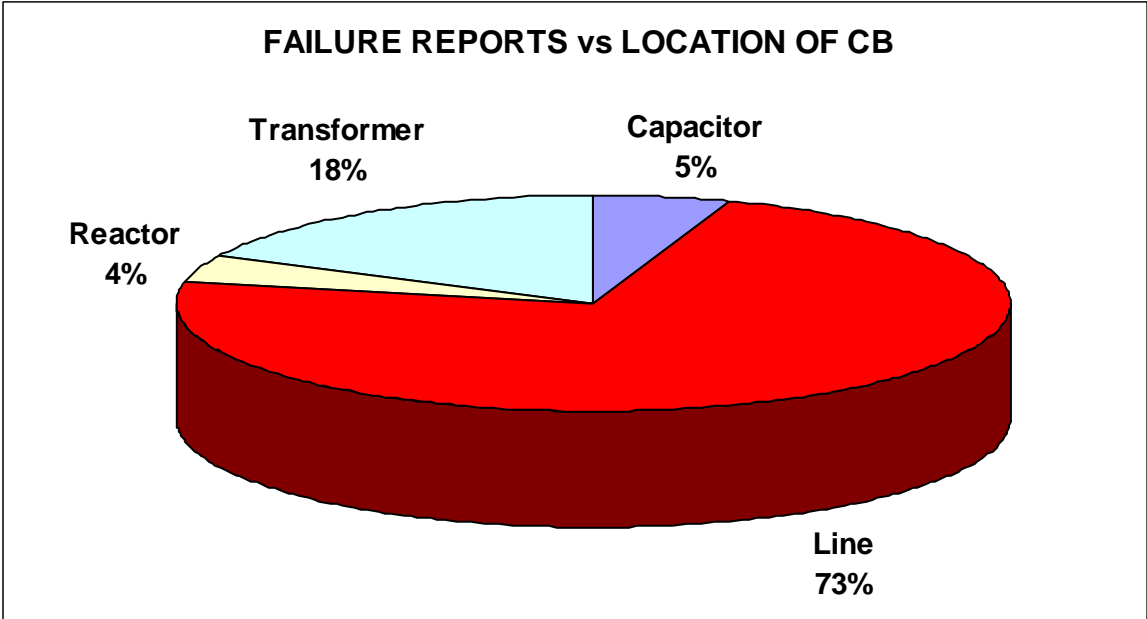

**Figure 3.2: Circuit Breaker application**

(Figure 3.2). These percentages remain fairly stable across the different classifications of failure (major, minor, spurious operation, self-detected failure, etc ...) except for “unintended operation “. For this failure classification, the number of failures for transformer applications rises to 26 %, and the contribution of line breakers decreases to 64 %.

3.1.3 Distribution by Voltage Class

Contrary to previous international enquiries on failures and stress conditions of circuit breakers, the population in the lower voltage range is not the overwhelmingly largest contributor to the total number of reported incidents. Failures are more evenly distributed across the overall voltage range (Fig. 3.3).

Failure to operate on command represents the most frequent type of problem for breakers between 110 kV and 380 kV, whereas minor failures (mostly discovered by inspection) tend to predominate at both extremes of the range.

3.1.4 Distribution by Technology

There are differences in the circuit breaker technology and the type of mechanisms found in this enquiry. Figures 3.4 and 3.5 illustrate the diversity of the type of circuit breakers and mechanisms for the reported incidents vs. the geographic region.

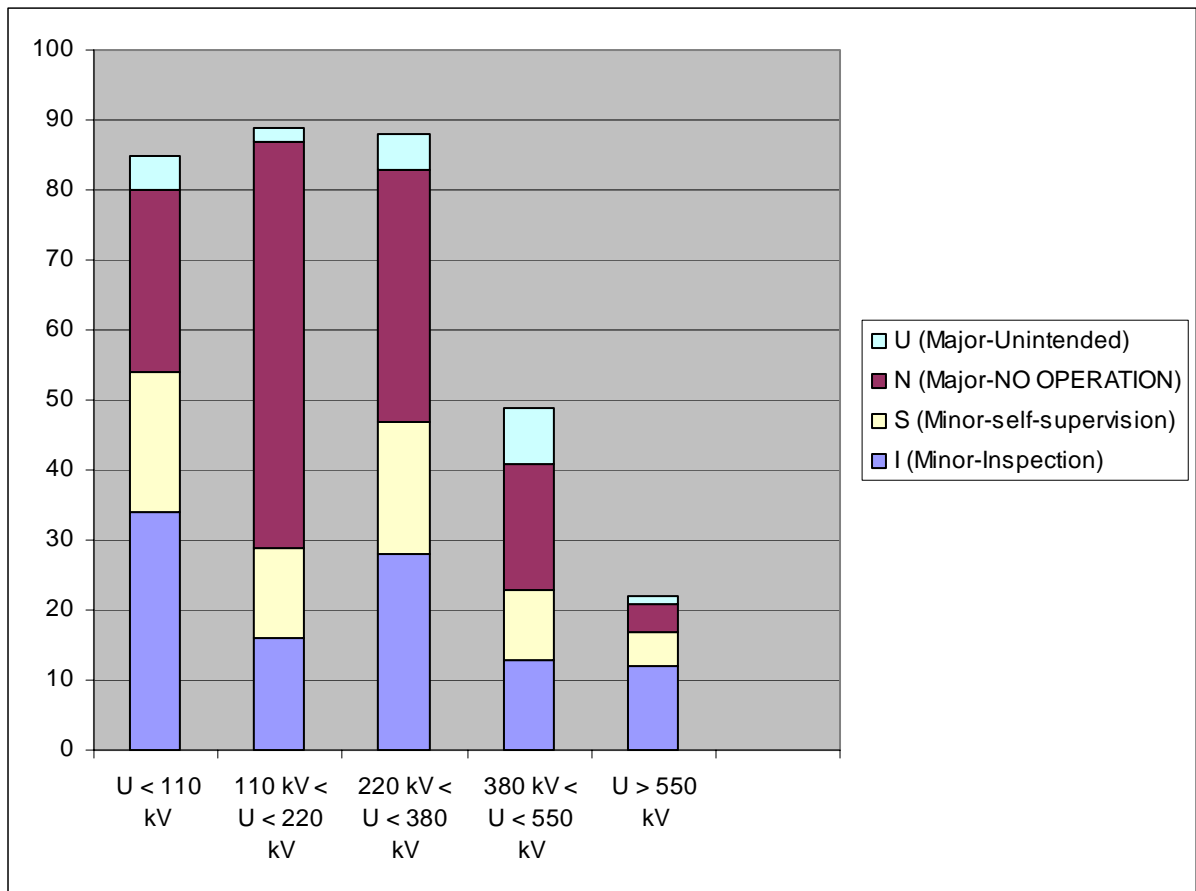

**Figure 3.3: Failure reports number vs. voltage level**

The overall results show the situation to be more balanced than expected, perhaps because there is still a significant proportion of non-SF<sub>6</sub> breakers (Fig . 3.6 & 3.7). While the bulk of the data comes from recent SF<sub>6</sub> breakers covering the entire voltage range, the older breakers tend to be found in the lower part of the range (oil technology ) and the upper part (air blast breakers ). A consequence of this situation is that comparison of failure modes between different technologies is very difficult, since each specific technology was primarily installed in a different period (i.e. recent SF<sub>6</sub> breaker compared to “old “oil breakers). This makes it difficult to separate the influence of technology from the influence of overall wear out and the differences in maintenance practices.

As can be seen in Figure 3.6 almost all new installed equipment is SF<sub>6</sub> technology. Therefore, in looking for future improvements for control system reliability, the focus should be on SF<sub>6</sub> technology.

The distribution of the type of failure incident with each technology is shown in Figures 3.10 and 3.11. The global number of failures is not higher for the older technologies (air blast, oil). This is probably due to specific maintenance programs targeted on these populations, as reported by many utilities. However, the higher complexity of these designs translates into a higher proportion of major failure compared to minor failures, thus supporting the policies of utilities which gradually take these technologies out of service.

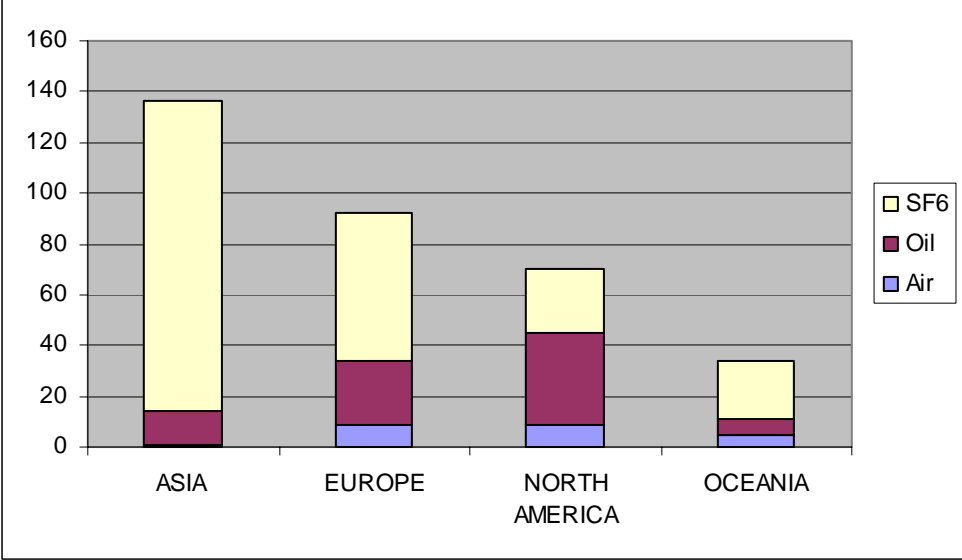

Figure 3.4: Geographical distribution of failure reports by breaker technology

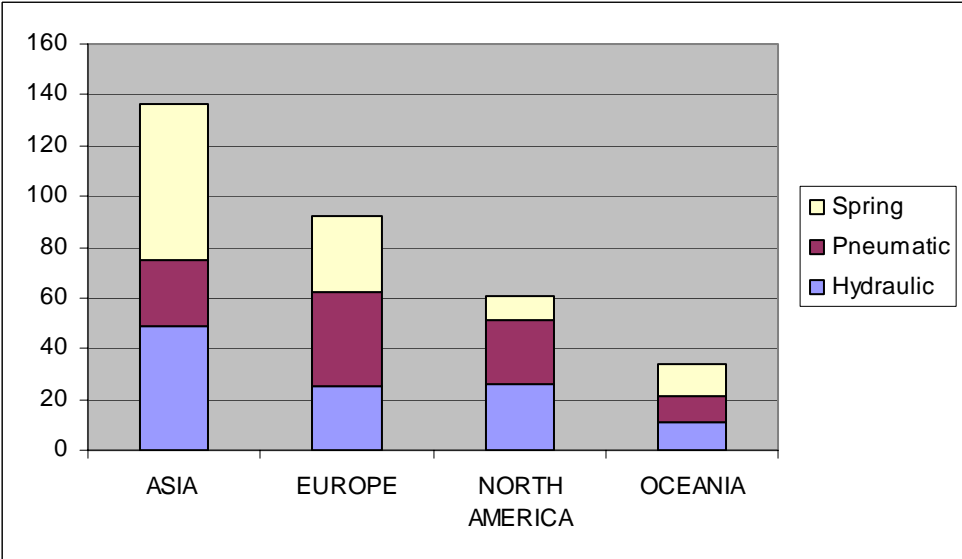
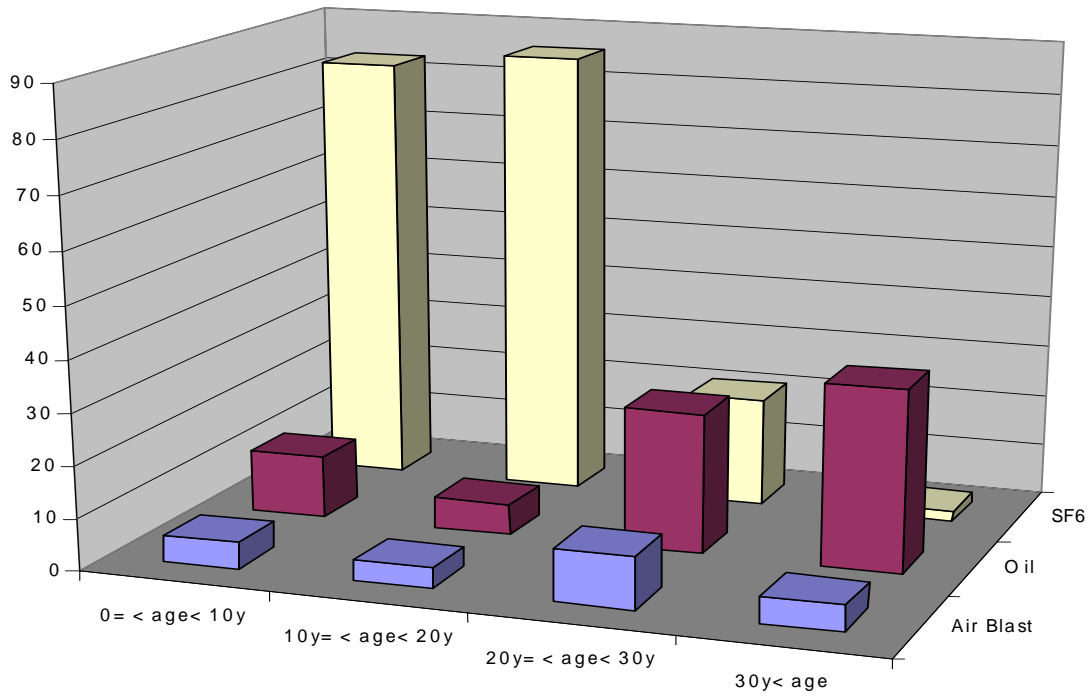

Figure 3.5: Geographical distribution of failure reports per breaker operating mechanism

**Failure report number per technology and years in service**



**Figure 3.6**

**Failure reports number per circuit breaker technology and voltage class**

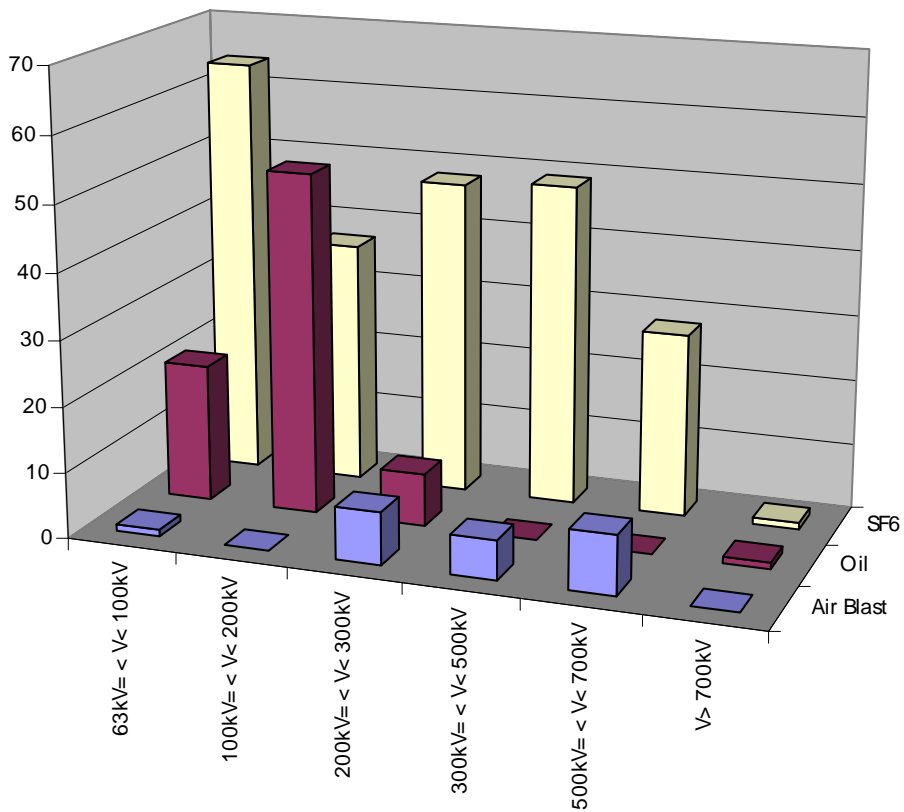

**Figure 3.7**

Air –type circuit breakers are 100% equipped with pneumatic drives. Oil type circuit breakers are mostly equipped with pneumatic drives (Fig. 3.8).

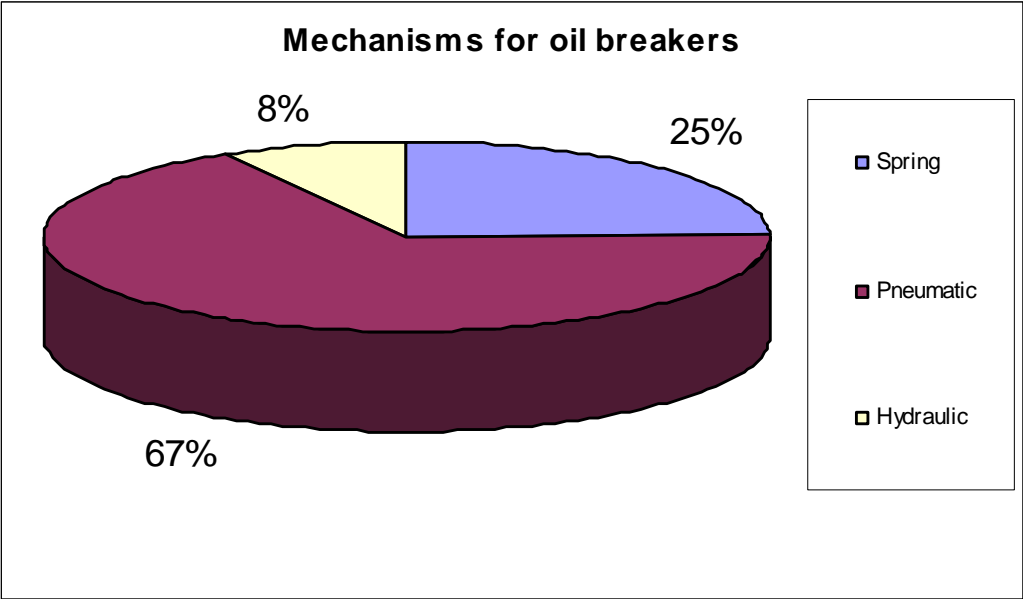

Figure 3.8

The SF<sub>6</sub> breakers in this enquiry are mainly equipped with hydraulic drives (Fig. 3.9). This may be surprising, but is still in line with the results of the second enquiry. The percentage of spring mechanisms has progressed steadily since 1994, but does not yet represent the majority of the data reported in this enquiry.

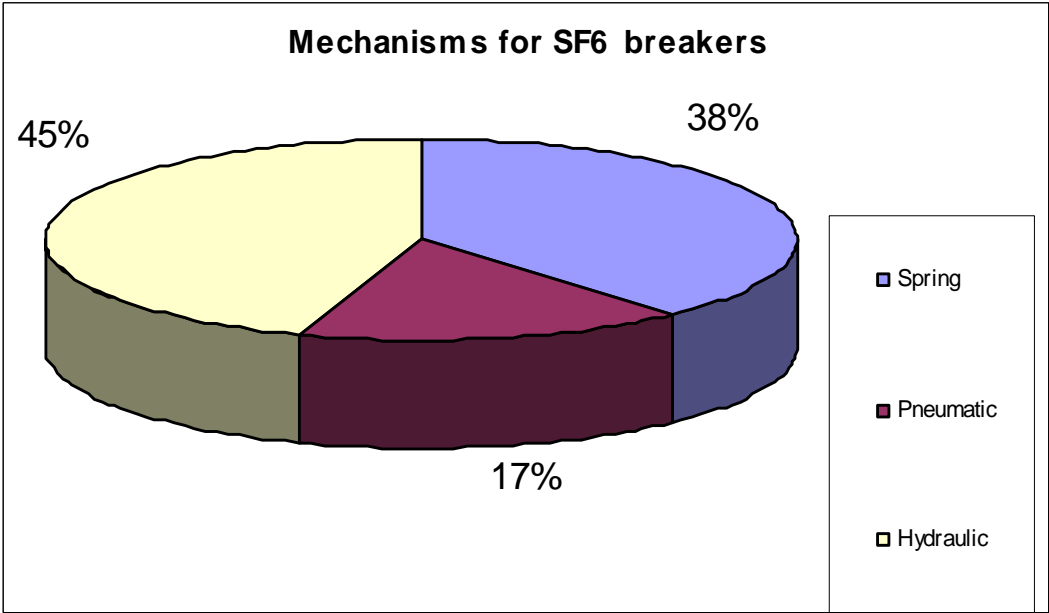
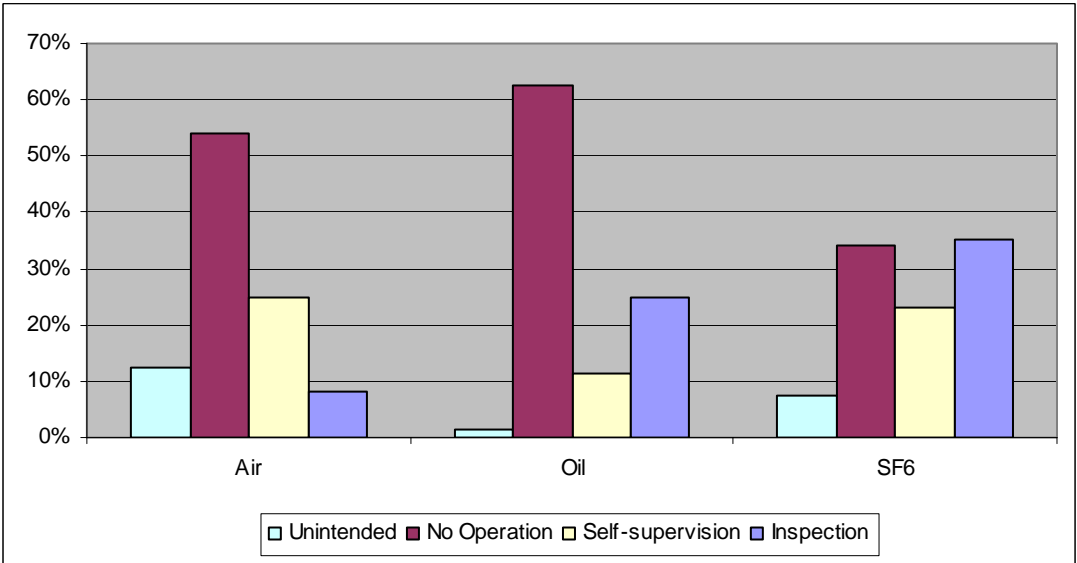

Figure 3.9

One of the objectives of this study was to check the specific failure modes related to different technologies and different mechanisms. Although earlier figures may suggest that technologies do

have an influence on failure frequency, Figure 3.11 suggests that there is no significant influence on control system failures linked to the type of mechanism.



**Figure 3.10: Failure reports vs. technology, % (sum of all failures for one technology = 100 % )**

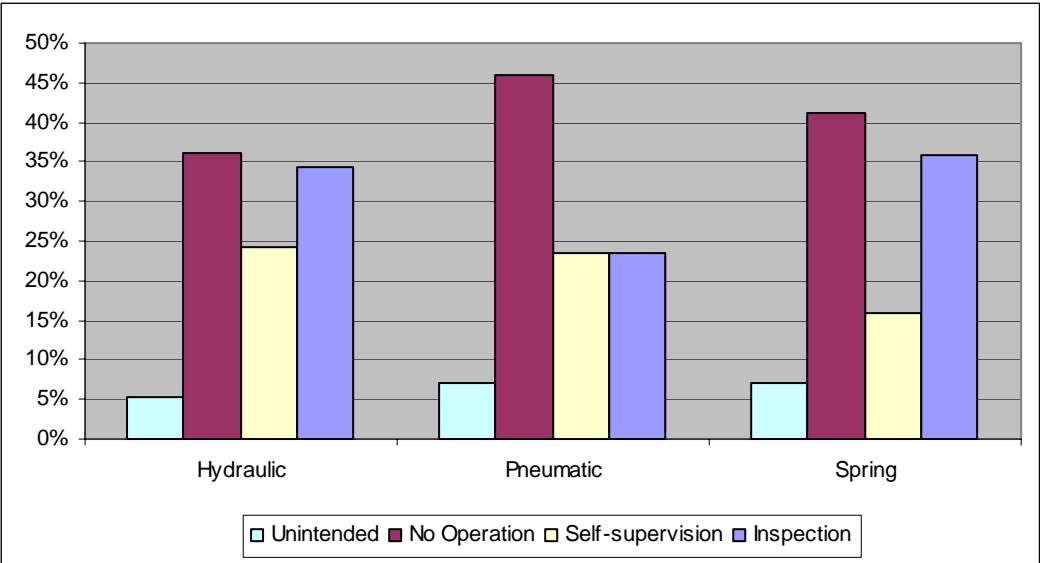

**Figure 3.11: Failure reports vs. operating mechanism, in % (sum of all failures for one technology = 100 % )**

3.2 Data analysis

Since we do not know the total population of breakers from which the reported control failures have been extracted, it is not possible to determine an overall failure rate from this data. As a result, a comparison with the results from the 1994 enquiry cannot be made and the data analysis is limited to an analysis of the cause of failure by component. The failures are evaluated by component using the component designation defined in Chapter 1.

Analysis of the data confirmed that the most frequent major failure mode for control circuits is failure to operate. Unintended operations represent only 13% of the major failures. The first analysis shows

### TOTAL FAILURE REPORTS vs COMPONENTS

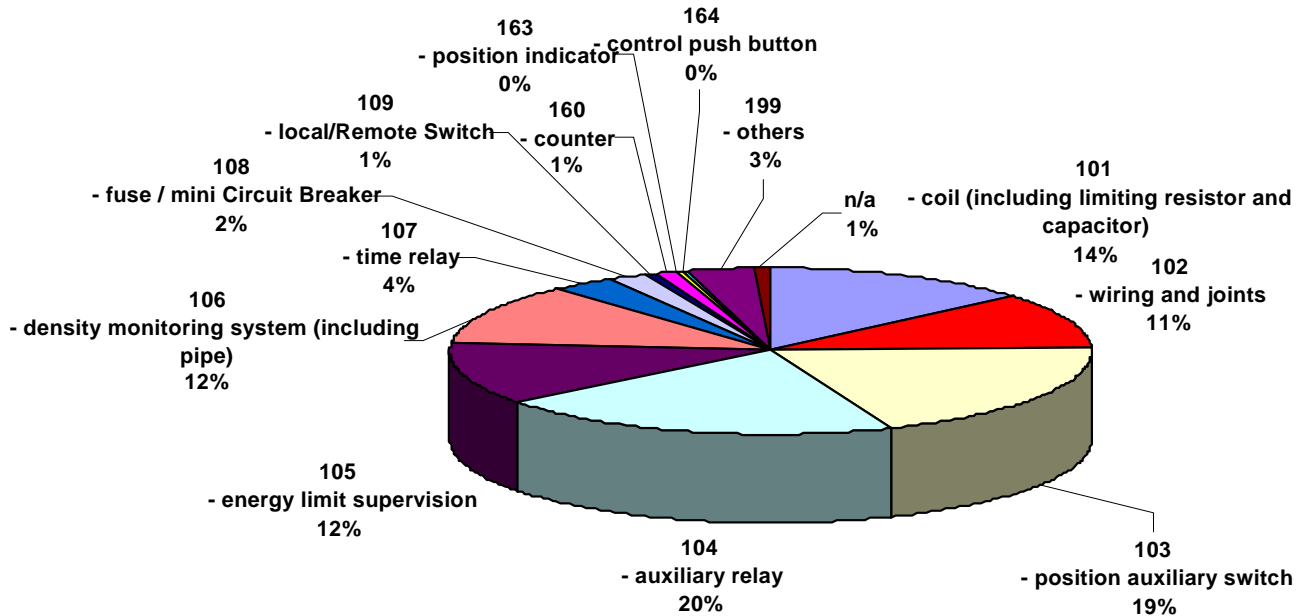

Figure 3.12

that it is difficult to identify a specific component as a major source of reliability problems. Evaluation shows that six (6) types of components make a significant contribution to the total number of failures (Fig. 3.12). The breakdown by component for major failures is shown in Figure 3.13 and for minor failures in Figure 3.14.

The six components, which account for 88% of all control failures, are:

- ◆ Auxiliary relays
- ◆ Position auxiliary switch ( mechanical parts )
- ◆ Coils
- ◆ Energy limit supervision
- ◆ Density monitoring ( including associated piping)
- ◆ Wiring and joints

The three largest contributors (auxiliary relays, position auxiliary switches and coils), account for 53% of all failures. This pattern is valid for both minor and major failures, except that the contribution of coil and position auxiliary switch failures doubles for major failures compared to minor failures,

accounting for 44 % of major failures (Fig. 3.13). On the other hand auxiliary relays account for 25 % of minor failures (Fig. 3.14).

### MAJOR FAILURES REPORTS vs COMPONENTS

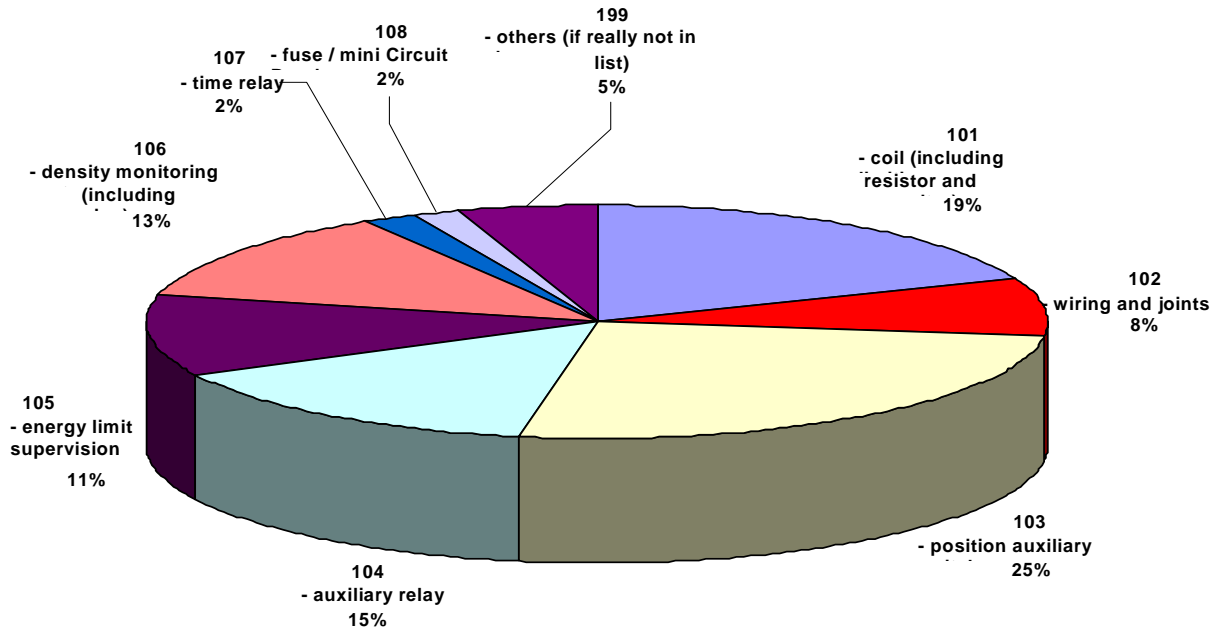

Figure 3.13

### MINOR FAILURE REPORTS vs COMPONENTS

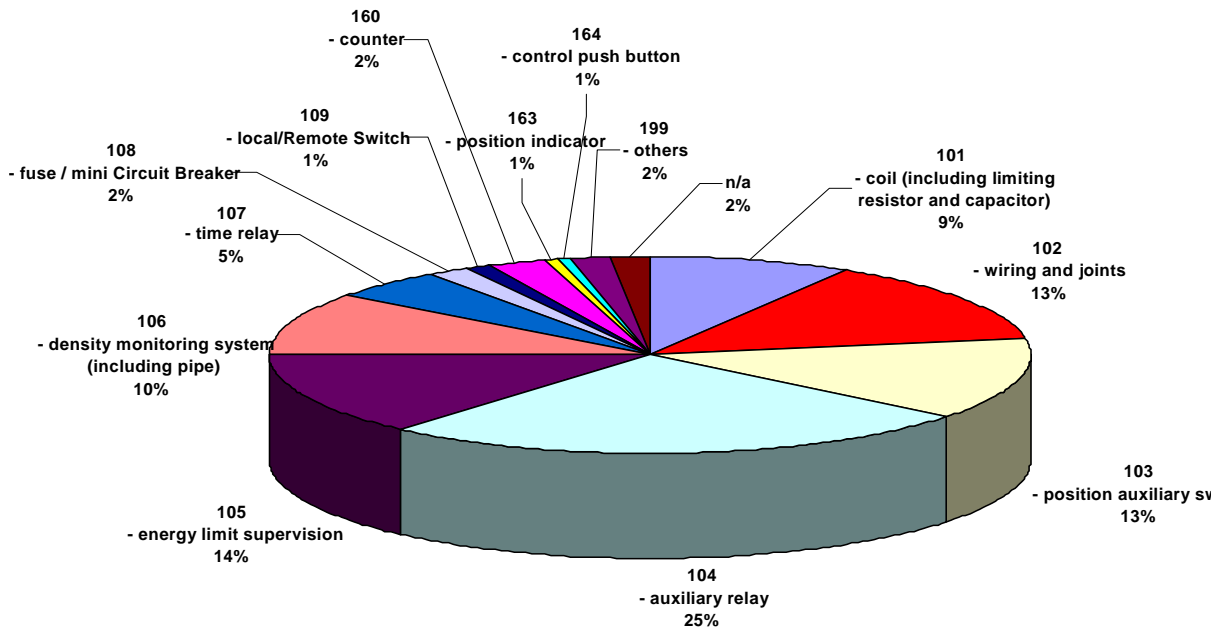

Figure 3.14

Since data was obtained for various technologies (e.g. oil, air blast, SF<sub>6</sub>), it is possible to summarize the reported failure data by component as a function of the technology. This data is summarized in Figures 3.15, 3.16, and 3.17 for air, oil and SF<sub>6</sub> technologies respectively. The Working Group concluded, however, that no meaningful comparisons or conclusions could be drawn from this data due to the relative ages of the circuit breakers. Since the oil and air technologies are older than the SF<sub>6</sub> technology, any relative comparison of the data might be unduly influenced by the relative ages of the circuit breakers.

Similarly, the data is also summarized by mechanism type in Figures 3.18, 3.19, and 3.20. Again, the variability in the relative ages of the circuit breakers makes any relative comparison of the data inappropriate. This data is presented for information purposes.

Some general conclusions can be drawn from this first global view:

- Major failures and minor failures represent 50 % each of the answers received. This is a major difference from the second enquiry in 1994 where minor failures were roughly ten times more numerous than major, but more in line with the results of the first international enquiry. This is probably due to the fact that the latest enquiry contains only 67 % of answers relating to SF<sub>6</sub> technology (both single and double pressure) whereas the second enquiry dealt solely with single pressure SF<sub>6</sub> breakers. As illustrated by Figures 3.10 and 3.11, SF<sub>6</sub> breakers exhibit a much higher minor/major failure ratio.
- The number of failures related to devices dedicated to monitoring and measurement of data in the control portion of the circuit (i.e. density supervision, energy limit supervision, position indication through auxiliary switches) is roughly equal to those related to “operational” components (i.e. coils, relays, fuses, joints). As the enquiry responses related almost entirely to conventional monitoring systems, there is considerable potential for improvement of reliability of control and monitoring systems of circuit breakers through replacement of these conventional monitoring devices by new systems and concepts based on new sensors and digital electronics.
- SF<sub>6</sub> gas density monitoring failures are no longer the major problem identified in the Second International Enquiry. Fig 3.12 and 3.13 show that density monitoring systems cause less than 12 % of total failures of control circuits whereas, in 1994 it was reported to account for over 15%. However, the ratio of major failures to minor failures has risen conspicuously from 5.3%/18.5% to 12.9%/10.2%.
- It was observed that the number of mechanical failures is proportional to the number of operations but not to the age of the breaker.
- The majority of failures are not related to mechanical failure of components, but to electrical failure, loss of properties, etc

**Breakdown of failure reports by components for AIR technology**

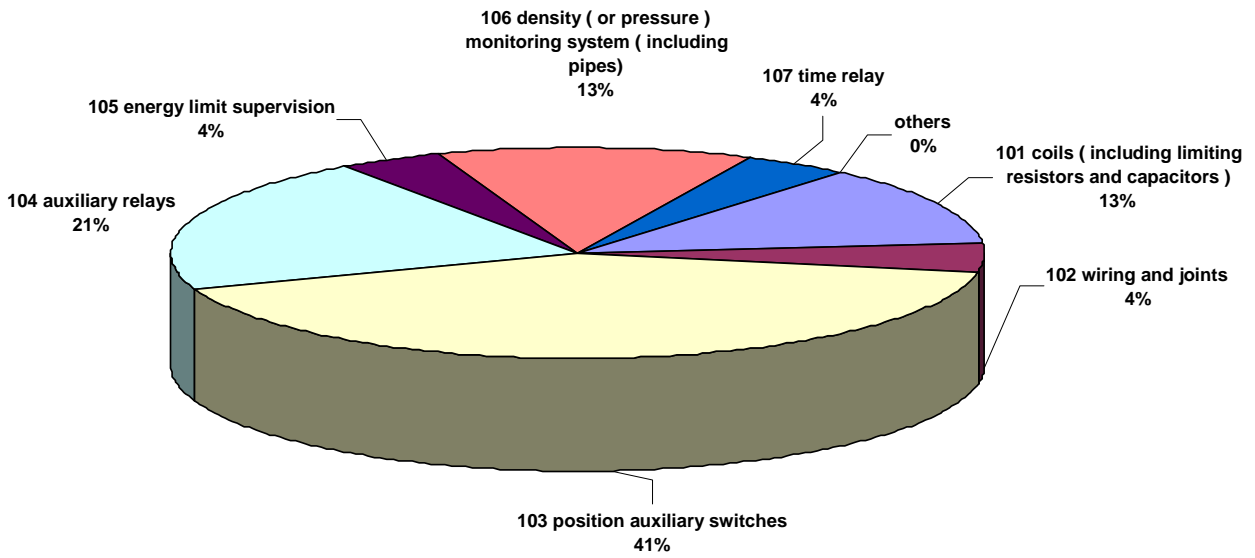

**Figure 3.15**

**Breakdown of failure reports by components for OIL technology**

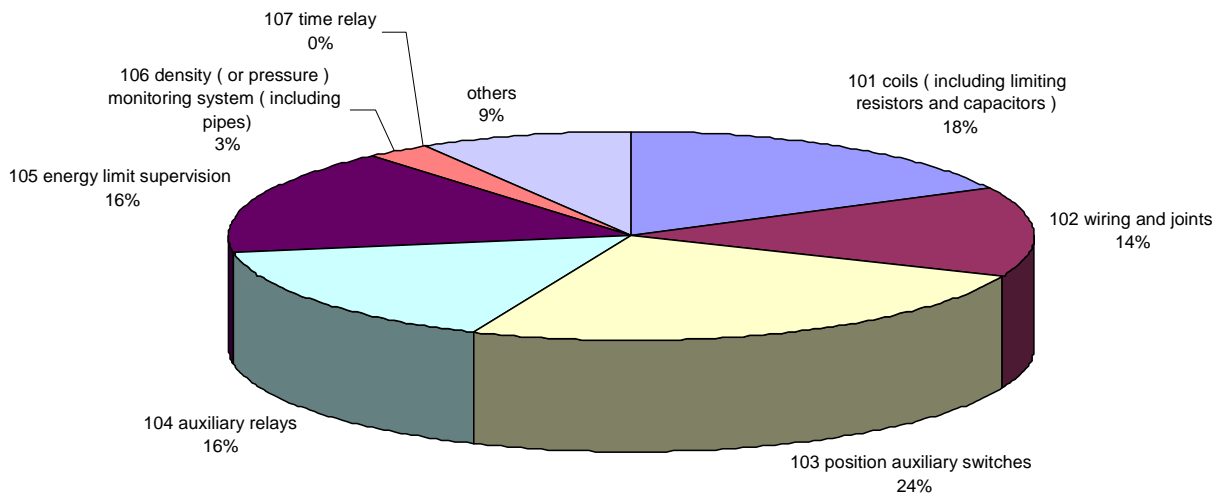

**Figure 3.16**

**Breakdown of failure reports by components for SF6 technology**

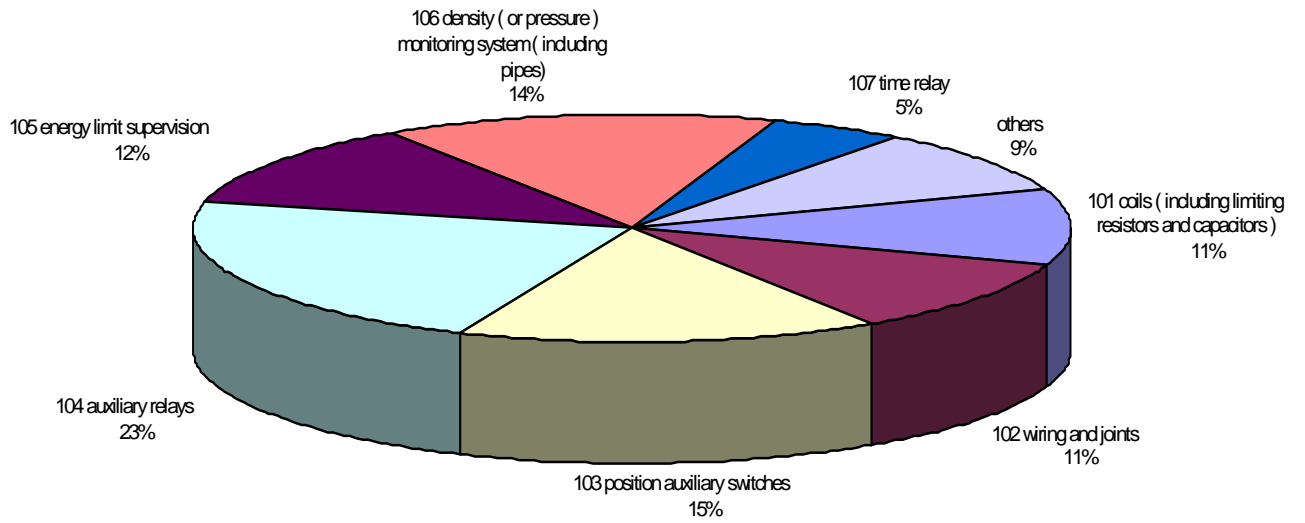

**Figure 3.17**

**Breakdown of failure reports for hydraulic mechanisms by components**

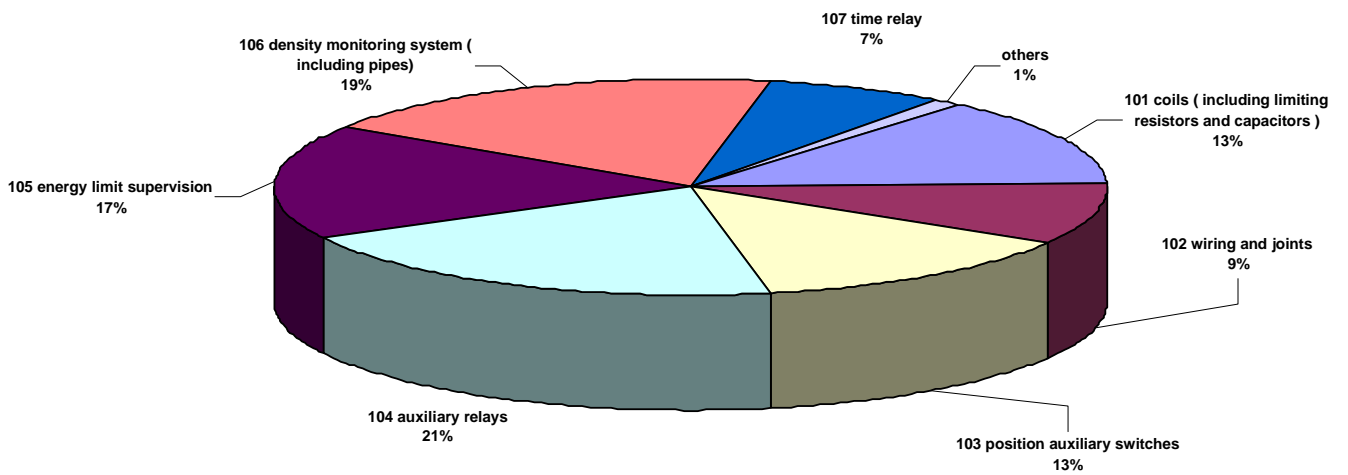

**Figure 3.18**

### Breakdown of failure reports for pneumatic mechanisms by components

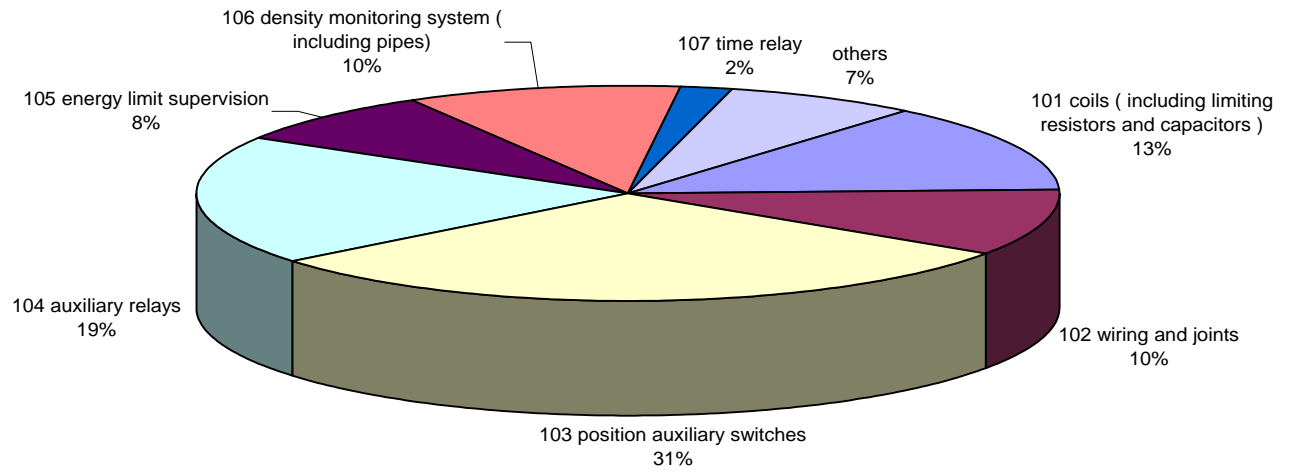

**Figure 3.19**

### Breakdown of failure reports for spring mechanisms by components

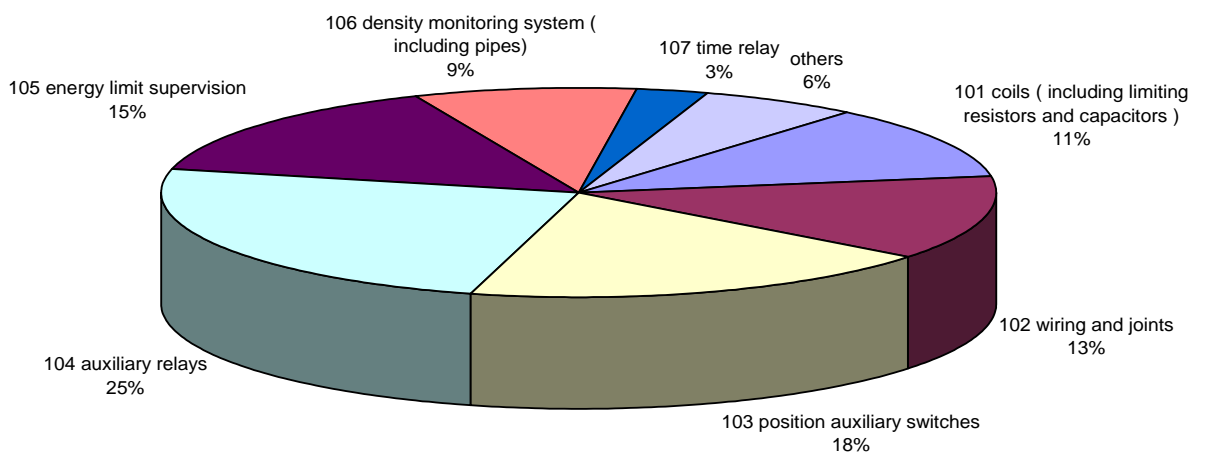

**Figure 3.20**

### 3.3 Timing of Failures

The timing of the reported failures was analyzed. This included analyzing the years since the last maintenance and the number of operations prior to the failure. It should be noted that, although this information was requested on the survey form, it was not reported for all of the failures. Many of the reported failures did not record the number of years since the last maintenance or the number of operations. For these cases, the failures where the information was not reported were eliminated and the analysis was performed for the remaining cases where the data was reported. As pointed out in Figure 3.6 almost all new installed equipment is SF<sub>6</sub> technology therefore the analysis is only based on SF<sub>6</sub> technology.

#### 3.3.1 Number of failures since last maintenance

From our database, we have information about years in service and years since last maintenance for 139 SF<sub>6</sub> breakers. The distribution for SF<sub>6</sub> circuit breakers only is shown in Figure 3.21. The data for time since the last maintenance operation is shown in Figure 3.22 for both major and minor failures for SF<sub>6</sub> circuit breakers.

The distribution of failures for SF<sub>6</sub> circuit breakers is approximately the same as for all breakers. The percentage by component is within +/- 4% for the SF<sub>6</sub> breakers vs all breakers.

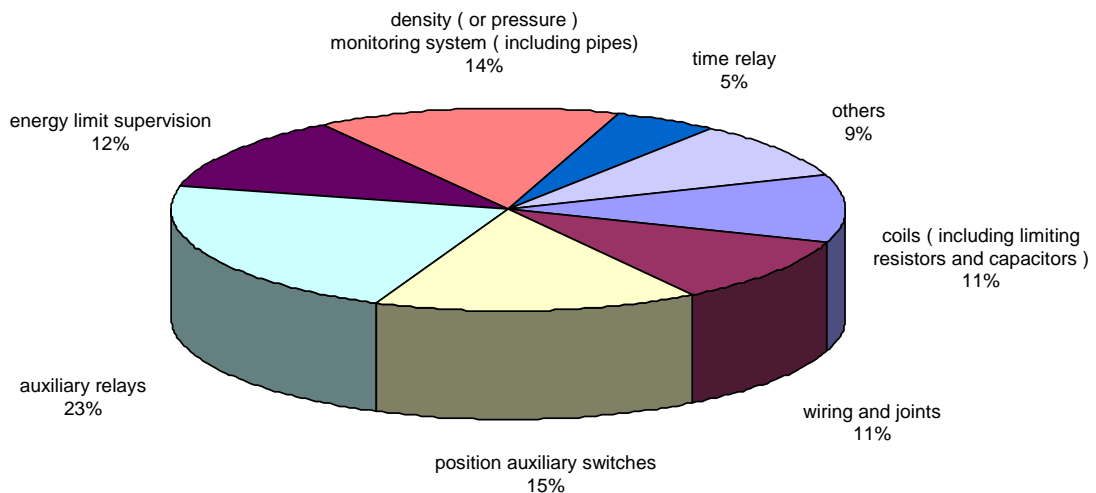
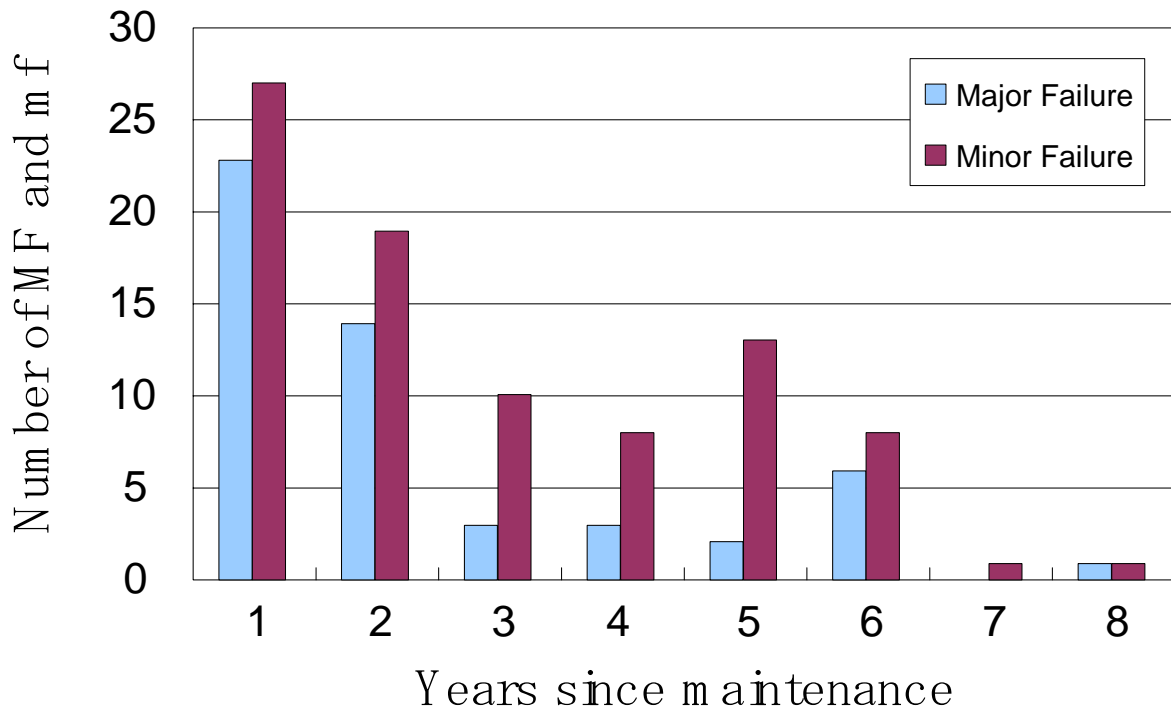

**Figure 3.21**

### **Breakdown of failures by Components for SF6**

A trend is observed in Figure 3.22 where a higher percentage of the failures are observed in the first 1-2 years after maintenance is performed. The number of failures seems to decrease after the first 1-2 years to a lower rate. This is observed for both the major and minor failures, but is more pronounced for the major failures.

The observation is thought to not be related to the specific activity performed, but instead, is likely related to the potential for human error during such operations. Therefore, the observation is interpreted as indicating that proper training and care should be taken whenever work is performed in the circuit breaker since there is the potential to make human error during these operations.



**Figure 3-22:**  
**Years of Failures since last maintenance**

3.3.2 Number of failures as a function of the number of operations

A cumulative distribution of the major and minor failures as a function of the number of operations is summarized in Figure 3.23. The key conclusion from this data is that the number of failures does not increase significantly with the number of operations. Approximately 87% of both the major and minor failures occur at less than 1,000 operations.

### Failure Frequency vs. Number of Operations

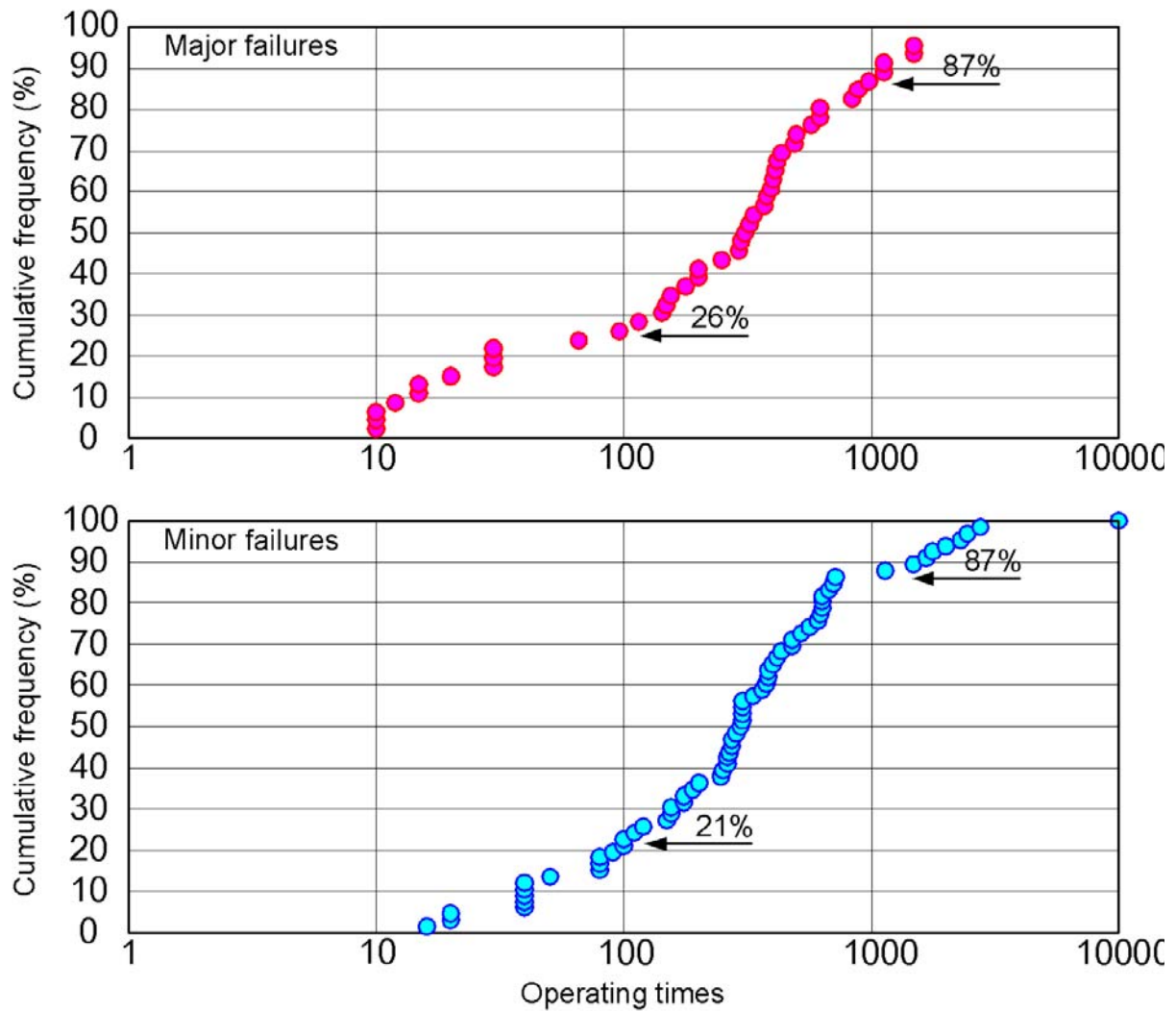

Figure 3.23

#### 3.4 Analysis of minor failures

One of the objectives of the Working Group was to see if the data showed any trends towards the increased use of monitoring and minor failures were of particular interest in this area. This was one of the reasons for dividing the minor failures into the inspection and self-supervision categories.

The majority of minor failures (61 %) are still detected by inspection. Only 39 % of minor failures are detected by self-supervision. It is suspected that this observation is partly the result of our sample and that modern SF<sub>6</sub> breakers, which include more supervision systems, would show a larger proportion of self-detected failures.

The breakdown of self-supervision (S) and inspection (I) minor failures as a function of components is shown in Figures 3.24 and 3.25. The conclusions from Fig. 3.14 remain valid. As shown in Figure 3.24, the number of coil minor failures detected by self supervision remains surprisingly low (1% of these failures), given the many coil continuity supervision systems installed on control circuits.

A comparison of the minor failures for SF<sub>6</sub> circuit breakers compared to minor failures for all reported data in this survey is summarized in Figure 3.26.

COMPONENT	Failures
- coil (including limiting resistor and capacitor) 101	1%
- wiring and joints 102	10%
- position auxiliary switch 103	6%
- auxiliary relay 104	38%
- energy limit supervision 105	14%
- density monitoring system (including pipe) 106	12%
- time relay 107	13%
- fuse / mini Circuit Breaker 108	4%
- local/Remote Switch 109	0%
- counter 160	0%
- position indicator 163	0%
- control push button 164	0%
- others (if really not in above list) 199	1%

**Figure 3.24: Minor failures detected by self-supervision by component**

COMPONENT	Failures
- coil (including limiting resistor and capacitor) 101	13%
- wiring and joints 102	16%
- position auxiliary switch 103	19%
- auxiliary relay 104	18%
- energy limit supervision 105	13%
- density monitoring system (including pipe) 106	10%
- time relay 107	0%
- fuse / mini Circuit Breaker 108	0%
- local/Remote Switch 109	2%
- counter 160	4%
- position indicator 163	1%
- control push button 164	1%
- others (if really not in above list) 199	2%

**Figure 3.25: Minor failures detected by inspection by component**

COMPONENT		Failures (SF6)	Failures (All)	Ratio SF6/All
- coil (including limiting resistor and capacitor)	101	25	46	54,3%
- wiring and joints	102	24	37	64,9%
- position auxiliary switch	103	35	66	53,0%
- auxiliary relay	104	51	69	73,9%
- energy limit supervision	105	28	42	66,7%
- density monitoring system (including pipe)	106	33	39	84,6%
- time relay	107	11	12	91,7%
- fuse / mini Circuit Breaker	108	4	6	66,7%
- local/Remote Switch	109	2	2	100,0%
- counter	160	4	4	100,0%
- position indicator	163	1	1	100,0%
- control push button	164	1	1	100,0%
- others (if really not in above list)	199	6	11	54,5%
n/a		3	3	100,0%
<b>TOTAL</b>		<b>228</b>	<b>339</b>	

**Figure 3.26: Analysis of mf and MF for SF<sub>6</sub> breakers**

## Chapter 4 Summary and Conclusions

### 4.1 Summary of Survey Results

CIGRE Working Group A3.12 compiled a survey of reliability data for circuit breaker control systems. Utilities from several countries were asked to provide data on control circuit related failures in the time period of 1998 through 2000. This limited time frame was intended to give results which are representative of current operation. Unlike the 1994 CIGRE enquiry that focused only on SF<sub>6</sub> circuit breakers, this study collected data for all types of circuit breakers (e.g. oil, air-blast, SF<sub>6</sub>) in order to find any trends that may exist. The data was limited to the High Voltage data (e.g. >69 kV) for purposes of this study. The survey was conducted by filling out a form drafted by the Working Group which collected the desired information. The key objectives of the study were: 1) to determine the nature of current control system failures, and 2) to determine if the failures are as frequent with more modern technologies or whether the failures are related to the older technologies.

The Working Group members compared control schemes used in the various countries and found that, although there were differences in some specific details and nomenclature, the general functionality of the control systems was basically the same from the various regions. Therefore, a general functional schematic was developed which summarized the required control circuit components and functions. This schematic is shown in Figure 1.1. The results of the survey were then tabulated and analyzed based on the components defined in this functional schematic.

Data was received from 27 utilities from 13 countries and 4 continents. A total of 339 failure reports were considered sufficiently complete that they could be used by the Working Group for evaluation. It should be noted that these reports addressed only failures in the circuit breaker control system. Several reported occurrences were deleted by the Working Group since the cause of the reported failure was due to a non-control circuit issue. Several limitations were noted in the data.

- A major limitation of the data is that the total number of circuit breakers in operation on the systems for which the data is reported is not known. Therefore, an overall failure rate can not be determined which limits the comparisons with the earlier inquiries. The analysis focused on the components that failed, which could be compared to the earlier surveys.
- For more than half of the data, although the specific component that failed was known, the actual cause of failure was not known in sufficient detail for use in detailed analysis.
- There appeared to be a difference in the reporting practices of the various regions. A very large number of the reported minor failures (inspection and self-supervision) were reported by one country. The Working Group felt that this is probably due to differences in maintenance and reporting practices rather than a difference in actual performance.

### 4.2 Key Conclusions

The data from the survey is summarized in Chapter 3 along with the analysis of data performed to date. Several conclusions of the analysis are summarized along with the analysis results. The key conclusions are summarized below:

- No single component was a major contributor to the reported failures. Instead, six (6) components accounted for the majority (88%) of the failures. These components and their percentage contribution to the major failures are summarized below. This observation is very similar to the results from the 1994 study.

- Auxiliary relays – 20%
- Auxiliary switches – 19%
- Coils – 14%
- Energy limit devices – 12%
- Gas density monitoring – 12%
- Wiring and joints – 11%

These results show that there is no single component that is responsible for all of the failures, but, instead, different components are responsible.

- Major and minor failures were approximately equal in number in this survey. This is a significant difference with the results of the second enquiry, but similar to the first enquiry.
- Although the distribution of the failures by component was very similar to the 1994 study for the major failures, there was a significant reduction in gas density monitoring failures for the minor failures in the current study than was reported in the 1994 study. This is assumed to reflect improvements in this technology.
- There was a trend observed for a higher tendency for failures in the first 1-2 years following a maintenance operation. This was interpreted as an indication of the potential for human error when maintenance work is performed on circuit breakers.
- The number of failures does not increase significantly with the number of operations.
- As almost all new installed capacities are SF<sub>6</sub> technologies. Therefore in looking for future improvements for control systems reliability the focus should be on SF<sub>6</sub> technology.

#### 4.3 Future Efforts

Future Working Group efforts will be to further review the results of the existing data and make recommendations on methods to improve the reliability of control systems. In addition, it was noted that the survey results provided little experience on more modern digital control systems. Future efforts will focus on the potential for digital control systems to provide alternatives to conventional technologies for improving control system reliability. This will include current state-of-the-art, experience, and industry needs.

#### 5.0 References

1. Final Report on Results of the Second International Enquiry into Circuit Breaker Reliability; CIGRE Brochure 83.
2. Mazza, G., Michaca, R., The First International Enquiry on Circuit-Breaker Failures and Defects in Service. Electra Nr. 79, December 1981, pp. 21-91.