

269

VSC TRANSMISSION

WORKING GROUP

B4.37

APRIL 2005



CIGRÉ

INTERNATIONAL CONFERENCE OF
LARGE HIGH-VOLTAGE ELECTRIC SYSTEMS

STUDY COMMITTEE B4
HVDC and Power Electronics

VSC Transmission

Copyright © 2005

“Ownership of a CIGRE publication, whether in paper form or on electronic support only infers right of use for personal purposes. Are prohibited, except if explicitly agreed by CIGRE, total or partial reproduction of the publication for use other than personal and transfer to a third party; hence circulation on any intranet or other company network is forbidden”.

Disclaimer notice

“CIGRE gives no warranty or assurance about the contents of this publication, nor does it accept any responsibility, as to the accuracy or exhaustiveness of the information. All implied warranties and conditions are excluded to the maximum extent permitted by law”.

FOREWORD

DC TRANSMISSION USING VOLTAGE SOURCED CONVERTERS

INTRODUCTION

HVDC Transmission was first put into commercial service in 1954 and has since been used extensively for the interconnection of asynchronous ac networks and for the transmission of power over long distances. The switching elements used for the conversion between ac and dc were able to switch on as commanded, but depended on a naturally occurring current zero for the turn-off process. Thus the technology relies on the presence of an ac voltage in the network for the commutation process, and is known as line commutated converter (LCC) HVDC technology. In this report it will be referred to as LCC HVDC. This technology is still used extensively for HVDC transmission. LCC HVDC schemes installed by the end of 2004 have a total rating in excess of 60 GW, with more being added each year.

The use of voltage sourced converters for dc power transmission (VSC Transmission) was introduced with the commissioning in 1997 of the 3MW, +/-10kVdc technology demonstrator at Hellsjön, Sweden. VSC Transmission enables reliable and controllable power transfer between networks. In principle, the operation of its converters (rectifier and inverter) at the two ends of the VSC Transmission does not rely on the strength of the connected ac systems. Furthermore, it provides independent control of the reactive power at the two ends and independently of the active power transfer over the dc transmission.

The objective of this document is to describe the VSC Transmission technology, with a particular view to the issues to be considered when it is applied at voltages above 100 kVdc, and power in excess of 100 MW. The book provides information about the equipment included in a VSC Transmission scheme, as well as the characteristics and performance that can be expected.

The information presented here is aimed at several groups of people:

- Transmission network owners/operators planning to build a VSC Transmission scheme
- Those involved in the specification of a VSC Transmission scheme, e.g., transmission or distribution network owners/operators
- Investors considering inter-connectors and other merchant transmission links
- Anyone wanting to know more about the VSC Transmission technology

Some readers may have technical interests and some may have non-technical interests. Therefore, the document has been structured such that different needs can be met by reading selected sections.

For readers without particular interest in the detailed technical issues, the chapters expected to be of greatest interest are:

- Chapter 2 VSC Transmission Applications
- Chapter 10 Environmental Impact
- Chapter 13 Life Cycle Cost
- Chapter 14 Comparison of Line Commutated Converter and VSC

For readers wanting a deeper insight into the VSC Transmission technology, but without knowledge of LCC HVDC technology, it may be advantageous to read Appendix C, "Overview of LCC HVDC," before reading the rest of the document.

OVERVIEW OF VSC TRANSMISSION TECHNOLOGY

Since its introduction in the early 1950s, LCC HVDC technology has undergone continuous development, particularly in the areas of converter switches and controls. Today LCC HVDC schemes provide reliable, efficient and cost effective solutions for many applications. The use of modern techniques have made it possible to obtain stable operation for LCC HVDC schemes connected to much weaker ac networks than was previously possible.

Other fields of power electronics, such as industrial drives, have tended to determine the development of new semiconductor devices, because the quantity of devices produced each year for these applications can be many times the number required for HVDC schemes. Motor drives have, over the years, moved on from using line commutated converters to the use of voltage sourced converters (VSC) with pulse width modulation (PWM) control, which results in compact and more controllable drives. Usually such drives operate at relatively low ac and dc voltage and do not use series-connected semiconductors.

The 3-MW Hellsjön VSC transmission installation put into service in Sweden in 1997 was an extension of modern motor drive technology. To reach a transmission voltage of 10 kVdc, however, series-connected semiconductors were required. The trial installation proved the feasibility of the technology and demonstrated its superior technical capability when compared to LCC HVDC. Subsequently, more schemes have been installed, with the largest in service at the end of 2004 having a rating of 330 MW and ± 150 kVdc. CIGRÉ has given this new type of dc transmission the name VSC Transmission.

VSC Transmission has a number of technical features that are superior to those of LCC HVDC schemes and make it especially attractive for the following applications:

- Feeding into passive networks
- Transmission to/from weak ac systems
- Enhancement of an ac system
- Land cable systems
- Supply of offshore loads
- Connection to wind farms (on-shore or off-shore) or wave power generation
- In-feeds to city centres
- Multi-terminal systems

Continuing developments in semiconductors and VSC Transmission technology are likely to make VSC Transmission attractive in an increasing number of applications as research and development efforts continue to bring down the capital cost and power losses of the converters.

OVERVIEW OF THE DOCUMENT

The report consists of 16 chapters and three appendices.

Chapter 1 provides a list of definitions of symbols and terms introduced in the report. Where possible, the terminology for high-voltage direct current (HVDC) transmission, as defined in IEC 60633, has been used. The definitions included in Chapter 1 have been limited to those which are new, as far as HVDC Transmission is concerned.

Chapter 2 describes a VSC Transmission scheme as a black box and outlines the main characteristics of a VSC Transmission scheme, in particular the principles of active and reactive power control, and its operational characteristics. The chapter also outlines potential applications and the present status of VSC Transmission technology.

Chapter 3 presents the operational characteristics of a VSC Transmission scheme in greater detail, starting with the operation of a 2-level converter. The basic characteristics of 3-level and multi-level converters are described, as is the use of pulse width modulation (PWM).

Chapter 4 describes different converter topologies, which may be used for VSC Transmission. Simplified circuit diagrams are given for each of these topologies, along with their waveshapes.

Chapter 5 gives an overview of the switches, called VSC valves, which are used to convert between ac and dc. The chapter includes a description of the various semiconductors that could be used for a VSC valve, and outlines the design considerations for a high-voltage VSC valve.

Chapter 6 presents a typical power circuit diagram for a VSC substation, and outlines the characteristics of the other major power equipment that may be used.

Chapter 7 discusses the different modes of control that can be used for a VSC Transmission scheme, as well as the information needs and performance required. A possible hierarchy of controls is described, followed by a discussion of the controls for a number of different applications.

Chapter 8 discusses the fault performance and protection requirements for a VSC Transmission scheme. It outlines the mechanisms leading to different faults and their consequences. Faults (and transients) within the converter on the ac side and dc side are discussed.

Chapter 9 describes the harmonics generated by a VSC substation and various methods that can be adopted to minimise the need for filtering, including the use of multi-level or multi-pulse converters and PWM switching. The consequences of harmonics in power networks are outlined, and the design of ac and dc harmonic filters is presented.

Chapter 10 covers the environmental impact of a VSC substation. The topics include audible noise, electric and magnetic fields (EMF), and radio frequency interference (RFI).

Chapter 11 discusses the studies that may be performed as part of the planning and implementation of a VSC Transmission scheme. The studies include those needed as background to the investment decision, those required for the tender exercise, and those for the simulation of critical system tests.

Chapter 12 gives a brief overview of the testing and commissioning associated with a VSC Transmission scheme. The process to be followed is very similar to that used for HVDC or FACTS.

Chapter 13 outlines the life cycle cost of a VSC Transmission scheme, including the capital cost, power losses, maintenance, disposal costs, refurbishment, and the cost of unavailability.

Chapter 14 provides a brief comparison of LCC HVDC and VSC Transmission.

Chapter 15 looks ahead to the next generation of semiconductors and outlines developments that could further improve the characteristics the VSC Transmission technology and lead to an increase the number of installed VSC schemes.

Chapter 16 is a brief conclusion.

Appendix A gives a list of VSC Transmission schemes in operation at the end of 2004.

Appendix B provides a guideline for a functional specification of a VSC Transmission scheme.

Appendix C presents a brief overview of LCC HVDC transmission, and is primarily intended for those readers who have little or no knowledge of this technology. Included is a list of all LCC HVDC schemes in service at the end of 2004.

WORKING GROUP MEMBERSHIP

As the convenor of this Working Group, I have been fortunate to have the enthusiastic support of knowledgeable and hard working members. Each member has contributed many hours of effort, both between and during each meeting. We began in May 2001 and have held a total of seven meetings. I hope that the members have enjoyed our friendship and work as much as I have. Thank you to you all.

The members of the Working Group were:

Dr. Bjarne Andersen, Andersen PES, UK – Convenor
Mr. Henri Baerd, AREVA, France
Mr. Håkon Borgen, STATNETT, Norway
Mr. Narinder S. Dhaliwal, Manitoba Hydro, Canada
Dr. Abdel-Aty Edris, EPRI, USA
Mr. Mats Hyttinen, ABB, Sweden
Mr. Shoichi Irokawa, TM T&D, Japan
Mr. Éric Joncquel, EDF, France
Mr. Jussi Jyrinsalo, FINGRID, Finland
Mr. Wayne Litzenberger, BPA, USA
Mr. Claudio Pincella, CESI, Italy
Mr. Frank Schettler, SIEMENS, Germany
Mr. Kent Søbriink, ELTRA, Denmark
Mr. Masahiro Takasaki, CRIEPI, Japan
Prof. Nicholas A Vovos, University of Patras, Greece
Mr. Dennis Woodford, Electranix, Canada

The Working Group would like to thank Mr Dan Flanagan, Technical Editor at BPA, for his valuable assistance with the editing of the final document. Dan's efforts have saved the members much time and resulted in a good-looking document. Thank you Dan.

Dr. Bjarne Andersen
Convenor WG B4-37
August 2004

CONTENTS

1. DEFINITIONS	1-1
1.1 INTRODUCTION	1-1
1.2 LIST OF LETTER SYMBOLS	1-1
1.3 GENERAL TERMS RELATED TO CONVERTER CIRCUITS AND POLE TOPOLOGIES FOR VSC CIRCUITS.....	1-2
1.3.1 VSC Transmission	1-2
1.3.2 VSC Phase Unit.....	1-2
1.3.3 VSC Unit	1-2
1.3.4 VSC Substation.....	1-2
1.3.5 Two-Level Converter.....	1-2
1.3.6 Three-Level Converter	1-2
1.3.7 Multi-Level Converter.....	1-2
1.3.8 VSC Pulse Number p	1-2
1.4 VSC UNIT EQUIPMENT	1-3
1.4.1 VSC Valve	1-3
1.4.2 Diode Valve.....	1-3
1.4.3 VSC Valve Level.....	1-3
1.5 VSC SUBSTATION EQUIPMENT.....	1-3
1.5.1 Interface Transformer	1-3
1.5.2 Phase Reactor	1-3
1.5.3 VSC DC Capacitor.....	1-4
1.6 REFERENCES.....	1-4
2. VSC TRANSMISSION APPLICATIONS.....	2-1
2.1 INTRODUCTION	2-1
2.2 EXAMPLES OF POSSIBLE VSC TRANSMISSION APPLICATIONS.....	2-2
2.3 THE VOLTAGE SOURCE CONVERTER AS A BLACK BOX.....	2-2
2.4 THE PRINCIPLES OF ACTIVE AND REACTIVE POWER CONTROL	2-3
2.4.1 The Principle of Active Power Control	2-3
2.4.2 The Principle of Reactive Power Control.....	2-4
2.4.3 Basic PQ Diagram for a VSC Station	2-5
2.5 OPERATING PRINCIPLES OF A VSC TRANSMISSION SCHEME	2-6
2.6 LOSSES	2-6
2.7 SUMMARY OF THE BASIC CHARACTERISTICS OF VSC TRANSMISSION	2-6
2.8 REFERENCES.....	2-7
3. BASIC OPERATING PRINCIPLES OF VSC TRANSMISSION	3-1
3.1 INTRODUCTION	3-1
3.2 BASIC OPERATING PRINCIPLES OF TWO-LEVEL CONVERTERS.....	3-2
3.3 TWO-LEVEL VSC—THREE-PHASE CONFIGURATION.....	3-4
3.3.1 Terminal Voltages.....	3-4
3.3.2 Fundamental Frequency Equations—Square Wave Operation.....	3-5
3.4 ACTIVE AND REACTIVE POWER EQUATIONS	3-6
3.5 VSC CONTROL AND HARMONICS	3-7
3.6 REFERENCES.....	3-7
4. VSC TRANSMISSION TOPOLOGIES	4-1
4.1 INTRODUCTION	4-1
4.2 CONVERTER PHASE UNIT TOPOLOGIES.....	4-1
4.2.1 Converter Phase Unit Topologies—General Aspects.....	4-2
4.2.2 Two-Level Converter.....	4-3
4.2.3 Three-Level Neutral Point Clamped Converter	4-4
4.2.4 Multi-Level Neutral Point Clamped Converter.....	4-5
4.2.5 Three-Level Floating Capacitor Topology.....	4-6
4.2.6 Multi-Level Capacitor Topology.....	4-7
4.3 COMBINATION OF CONVERTER PHASE UNITS	4-8
4.3.1 General	4-8
4.3.2 Combination Using Separate Transformer Windings	4-9

4.3.2.1 Series Connection of Converters	4-9
4.3.2.2 Parallel Connection of Converters.....	4-10
4.3.2.3 Series and Parallel Connection on the DC Side.....	4-11
4.4 CONCLUDING DISCUSSION	4-12
4.4.1 Converter Phase Unit Topologies.....	4-12
4.4.2 Combination of Converter Units.....	4-12
4.5 REFERENCES.....	4-13
5. VSC TRANSMISSION VALVES.....	5-1
5.1 INTRODUCTION	5-1
5.2 SEMICONDUCTORS FOR VSC TRANSMISSION.....	5-1
5.2.1 Overview of High Power Semiconductors.....	5-1
5.2.2 Thyristors.....	5-1
5.2.3 GTOs and IGCTs (GCT).....	5-2
5.2.4 IGBT Type Devices	5-2
5.2.5 Comparison of Devices	5-3
5.3 VSC VALVE DESIGN CONSIDERATIONS	5-3
5.3.1 Reliability (IGBT).....	5-4
5.3.2 IGBT Current Rating.....	5-4
5.3.3 Transient Current Requirements.....	5-4
5.3.4 Diode Requirements.....	5-5
5.4 THERMAL DESIGN.....	5-5
5.4.1 Converter Power Losses	5-6
5.4.2 Cooling System Design	5-7
5.4.3 IGBT Losses.....	5-7
5.4.4 Voltage Rating	5-7
5.4.4.1 Aspects of Series Connection.....	5-7
5.4.4.2 Commutation Process.....	5-8
5.5 MECHANICAL STRUCTURE OF THE VALVE.....	5-9
5.6 VALVE HALL OR VALVE ENCLOSURES	5-9
5.7 REFERENCES.....	5-10
6. OTHER MAIN EQUIPMENT FOR VSC TRANSMISSION SCHEMES.....	6-1
6.1 INTRODUCTION	6-1
6.2 POWER COMPONENTS OF A VSC TRANSMISSION SCHEME	6-2
6.3 VSC SUBSTATION CIRCUIT BREAKER	6-2
6.4 AC SYSTEM SIDE HARMONIC FILTERS	6-3
6.5 RADIO FREQUENCY INTERFERENCE FILTERS	6-4
6.6 INTERFACE TRANSFORMERS AND PHASE REACTORS.....	6-4
6.7 CONVERTER SIDE HARMONIC FILTERS AND HF BLOCKING FILTER	6-5
6.8 VSC DC CAPACITOR.....	6-6
6.9 DC FILTER	6-7
6.10 NEUTRAL POINT GROUNDING BRANCH	6-7
6.11 DC REACTOR	6-8
6.12 COMMON MODE BLOCKING REACTOR	6-8
6.13 DC CABLE AND OVERHEAD TRANSMISSION LINES.....	6-9
6.14 SPECIAL ASPECTS FOR BACK-TO-BACK DC TRANSMISSION SYSTEMS	6-10
6.15 REFERENCES.....	6-10
7. VSC CONTROL	7-1
7.1 INTRODUCTION	7-1
7.2 MODES OF CONTROL.....	7-2
7.2.1 AC Voltage Control.....	7-3
7.2.2 Power Control.....	7-4
7.2.3 Reactive Power Control.....	7-4
7.2.4 DC Voltage Control	7-5
7.2.5 Current Control	7-5
7.2.6 Frequency Control.....	7-5
7.3 INFORMATION REQUIREMENTS FOR CONTROLS	7-6
7.4 PERFORMANCE OF CONTROLS	7-6
7.5 LEVELS OF CONTROLS	7-6
7.5.1 Firing Control.....	7-7
7.5.2 Converter Unit Control.....	7-7
7.5.3 System Control.....	7-7
7.6 COORDINATION OF CONTROLS	7-8

7.6.1	Supply to a Load with No Other Source of Generation.....	7-8
7.6.2	Interconnection of Two or More AC Power Systems.....	7-8
7.6.3	Telecommunication Between Converter Stations.....	7-10
7.6.4	Supply from a Wind Farm.....	7-11
7.7	REFERENCES.....	7-11
8.	FAULT PERFORMANCE AND PROTECTION REQUIREMENTS.....	8-1
8.1	PROTECTION SYSTEM PHILOSOPHY.....	8-1
8.2	TYPE OF PROTECTION AND FAULT CLEARING ACTIONS.....	8-2
8.3	VSC SUBSTATION PROTECTION.....	8-3
8.4	INTERNAL FAULTS IN THE VSC SUBSTATION.....	8-3
8.4.1	Internal AC Bus Fault.....	8-3
8.4.2	DC Bus Fault.....	8-4
8.4.3	Component Failure.....	8-4
8.4.3.1	VSC Valve Failure.....	8-4
8.4.3.2	DC Capacitor Failure.....	8-4
8.4.3.3	Phase Reactor Failure.....	8-4
8.5	EXTERNAL FAULTS AND SWITCHING TRANSIENTS ON THE AC SIDE.....	8-5
8.5.1	AC Voltage Dip.....	8-5
8.5.2	AC Temporary Overvoltage.....	8-5
8.5.3	AC Lightning Overvoltage.....	8-5
8.5.4	AC Switching Overvoltage.....	8-6
8.5.5	AC Voltage Phase Shifting.....	8-6
8.5.6	AC Voltage Phase Unbalance.....	8-6
8.5.7	DC Overvoltage.....	8-6
8.5.8	Post-Fault Recovery.....	8-7
8.6	FAULTS ON THE DC TRANSMISSION LINE OR CABLE.....	8-7
8.6.1	DC Cable Fault.....	8-7
8.6.2	DC Overhead Line Fault.....	8-7
8.6.3	DC Bus Overvoltage (dc overhead line only).....	8-7
8.6.4	DC Overvoltage.....	8-8
8.6.5	Other Protection Measures.....	8-8
8.7	REFERENCES.....	8-8
9.	HARMONIC PERFORMANCE.....	9-1
9.1	INTRODUCTION.....	9-1
9.2	WAVE DISTORTION.....	9-1
9.3	FUNDAMENTAL AND HARMONICS.....	9-2
9.3.1	Three-Phase 2-Level VSC.....	9-2
9.3.2	Pulse Width Modulation (PWM).....	9-2
9.3.3	Multi-Pulse and Multi-Level Converters.....	9-5
9.3.4	Comparison of the Harmonic Content at the AC Terminals of the VSC Valve Units.....	9-6
9.4	HARMONIC VOLTAGES ON POWER SYSTEMS DUE TO VSC OPERATION.....	9-7
9.5	DESIGN CONSIDERATIONS FOR HARMONIC FILTERS (AC SIDE).....	9-9
9.6	DC SIDE FILTERING.....	9-9
9.7	REFERENCES.....	9-10
10.	ENVIRONMENTAL IMPACT.....	10-1
10.1	INTRODUCTION.....	10-1
10.2	AUDIBLE NOISE.....	10-1
10.3	VISUAL IMPACT.....	10-2
10.4	ELECTRIC AND MAGNETIC FIELDS (EMF).....	10-2
10.5	ELECTROMAGNETIC COMPATIBILITY (EMC).....	10-2
10.6	REFERENCES.....	10-3
11.	APPLICATION STUDIES.....	11-1
11.1	INTRODUCTION.....	11-1
11.2	FEASIBILITY STUDIES.....	11-2
11.2.1	Economic Justification of a VSC Scheme.....	11-2
11.2.2	Comparing Alternative Termination Points for the VSC Scheme.....	11-3
11.2.3	Comparing the Selected Scheme with Alternative Solutions.....	11-4
11.2.4	Preparing an Outline Specification of the VSC Transmission Project.....	11-4
11.3	SPECIFICATION STUDIES.....	11-5
11.3.1	Specifying the Performance Requirements for the VSC Scheme.....	11-5
11.3.2	AC System Data for the Design of the VSC Scheme.....	11-6

11.4 IMPLEMENTATION STUDIES	11-7
11.5 MODELLING OF THE VSC SCHEME	11-7
11.5.1 Load Flow Modelling Requirements	11-8
11.5.2 Short-Circuit and Harmonic Modelling Requirements	11-8
11.5.3 Electromechanical Stability Modelling Requirements	11-9
11.5.4 Electromagnetic Transient Modelling Requirements	11-9
11.6 REFERENCES	11-10
12. TESTING AND COMMISSIONING	12-1
12.1 INTRODUCTION	12-1
12.2 THE TESTING AND COMMISSIONING PROCESS	12-1
12.3 FACTORY TESTS	12-2
12.3.1 Component Tests	12-2
12.3.2 Control System Tests	12-2
12.4 SITE TESTS (COMMISSIONING)	12-3
12.4.1 General	12-3
12.4.2 Precommissioning Tests	12-3
12.4.3 Subsystem Tests	12-3
12.4.4 System Tests	12-4
12.4.4.1 High-Voltage Energisation	12-5
12.4.4.2 Converter Operational Tests	12-5
12.4.4.3 Transmission Tests	12-6
12.4.5 Trial Operation	12-7
12.4.6 Acceptance Tests	12-7
12.5 REFERENCES	12-8
13. LIFE CYCLE COST	13-1
13.1 INTRODUCTION	13-1
13.2 DETERMINATION OF THE PROFITABILITY OF AN INVESTMENT	13-1
13.3 LIFE CYCLE COSTING	13-1
13.3.1 Operational Life	13-2
13.3.2 Interest and Inflation Rates—Calculation of Present Value	13-2
13.3.3 Initial Costs of the System	13-2
13.3.4 Cost of Spare Parts	13-2
13.3.5 Annual Costs of System Losses	13-2
13.3.6 Cost of Periodic Refurbishment	13-3
13.3.7 Annual Operating Costs of the System	13-3
13.3.8 Annual Maintenance Costs of the System	13-3
13.3.9 Annual Cost of Unavailability	13-3
13.3.10 Salvage Value or Disposal Costs of VSC Transmission Systems	13-4
13.3.10.1 Salvage Value	13-4
13.3.10.2 Disposal Cost	13-4
13.4 BENEFITS OF CONTROLLABILITY	13-4
13.5 REFERENCES	13-5
14. COMPARISON OF LINE COMMUTATED CONVERTER AND VSC	14-1
14.1 INTRODUCTION	14-1
14.2 DIFFERENCES RESULTING FROM THE COMMUTATION PRINCIPLE	14-1
14.2.1 Dependence on an AC Voltage Source	14-1
14.2.2 Reactive Power Consumption or Generation	14-1
14.2.3 Short-Circuit Level Requirement for Stable Operation	14-2
14.2.4 Harmonics and Filter Requirements	14-2
14.2.5 Overvoltages in the AC System	14-2
14.2.6 Robustness against AC System Faults	14-3
14.3 DIFFERENCES RESULTING FROM THE SOURCE TYPE	14-3
14.3.1 Protection against DC System Faults	14-3
14.3.2 Flexibility of the Power Flow Reversal in the Multi-Terminal HVDC System	14-3
14.3.3 Cost, Losses, Reliability and the Availability of the Large Scale HVDC System	14-4
14.4 SUMMARY	14-4
14.5 REFERENCES	14-6
15. VSC TRANSMISSION OUTLOOK	15-1
15.1 INTRODUCTION	15-1
15.2 FUTURE TRENDS	15-1
15.2.1 Reliability	15-1

15.2.2 Capital Cost of a VSC Transmission Installation.....	15-1
15.2.3 Controllable Switching Components.....	15-1
15.2.4 Power Losses	15-3
15.2.5 Increased DC Voltage and Power Rating of DC Extruded Cables	15-3
15.2.6 Utilisation of the Functionality and Controllability of VSC Transmission.....	15-3
15.3 REFERENCES.....	15-4
16. CONCLUSION	16-1

APPENDICES

APPENDIX A: LIST OF VSC TRANSMISSION SCHEMES	A-1
1 HVDC TJUJA-ASHU-SUSAMYR, REGIONAL PS OF KIRGIZIYA SSR	A-1
2 HELLSJÖN HVDC LIGHT, VB ELNÄT, SWEDEN	A-2
3 INTERCONNECTION REINFORCEMENT PROJECT, CRIEPI, JAPAN	A-3
4 GOTLAND HVDC LIGHT PROJECT, VATTENFALL AB, SWEDEN	A-5
5 TJAEREBORG HVDC LIGHT, ELTRA, DENMARK	A-7
6 DIRECTLINK HVDC LIGHT, TRANSENERGIE, AUSTRALIA	A-9
7 EAGLE PASS, CSW CORP., DFE, MEXICO-USA BORDER.....	A-11
8 MURRAY LINK HVDC LIGHT PROJECT, TRANSENERGIE, AUSTRALIA	A-13
9 CROSS SOUND HVDC LIGHT PROJECT, TRANSENERGIE, USA	A-14
10 TROLL, A PRECOMPRESSION ELECTRICAL DRIVE SYSTEM, STATOIL, NORWAY.....	A-15
APPENDIX B: FUNCTIONAL SPECIFICATION FOR A VSC TRANSMISSION SYSTEM	B-1
1 INTRODUCTION	B-1
2 UTILITY AND MANUFACTURER INFORMATION REQUIREMENTS	B-1
2.1 General Requirements.....	B-2
2.2 Power System Characteristics.....	B-2
2.3a DC Line/Cable (Turnkey, supplied by the converter manufacturer)	B-3
2.3b DC Line/Cable (Not supplied by the converter manufacturer)	B-3
2.4 Steady-State Performance.....	B-3
2.5 Dynamic Performance, Control and Monitoring Facilities	B-4
2.6 Maintenance, Test and Spares	B-5
2.7 Site and Environmental.....	B-5
2.8 Factory and Commissioning Tests	B-5
2.9 Other Considerations.....	B-6
3 EQUIPMENT DESIGN STANDARDS	B-6
APPENDIX C: OVERVIEW OF LINE COMMUTATED CONVERTER BASED HVDC	C-1
1 INTRODUCTION	C-1
2 SYSTEM CONFIGURATION	C-1
2.1 Converters.....	C-2
2.2 Converter Transformers.....	C-3
2.3 Harmonic Filters.....	C-3
2.4 Shunt Capacitors.....	C-3
2.5 DC Reactors.....	C-3
2.6 DC Connections	C-3
3 HVDC SYSTEM CONTROL AND OPERATING CHARACTERISTICS.....	C-3
4 LIST OF LCC HVDC SCHEMES	C-5
5 REFERENCES	C-7

1. DEFINITIONS

1.1 INTRODUCTION

This report uses the terminology established by IEC 60633, *Terminology for high-voltage direct current (HVDC) transmission* [1-1]. However, due to the differences in converter technology and operating characteristics of voltage sourced converters (VSC) compared to line commutated converters (LCC), the Working Group has felt it appropriate to define some new terms used in this report. Those terms that are either identical to or obvious extensions of the IEC 60633 terminology have not been defined.

To support the explanations, Figure 1.1 presents the basic diagram of a VSC substation.

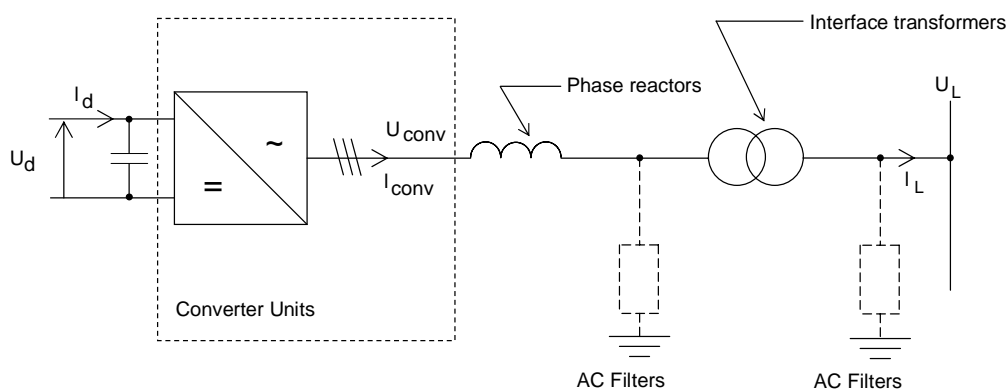

Figure 1.1: Basic diagram of a VSC substation

For the purpose of this report, the symbol for a VSC valve is as shown in Figure 1.2.

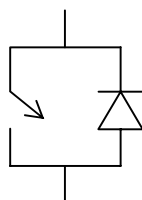

Figure 1.2: Symbol of a VSC valve as used in this report

1.2 LIST OF LETTER SYMBOLS

- U_{conv} Line-to-line ac voltage of the converter unit(s), rms value, including harmonics
- $U_{\text{conv-ph}}$ Phase-to-Phase ac voltage of the converter unit(s), rms value, including harmonics
- I_{conv} Alternating current of the converter unit(s), rms value, including harmonics

1.3 GENERAL TERMS RELATED TO CONVERTER CIRCUITS AND POLE TOPOLOGIES FOR VSC CIRCUITS

1.3.1 VSC Transmission

A high-voltage dc transmission system in which the conversion between ac and dc, and vice versa, is performed by means of voltage sourced converters.

1.3.2 VSC Phase Unit

The equipment used to connect the two dc busbars to one ac terminal.

Note: In the simplest implementation, this consists of two VSC valves. The VSC phase unit may also include control and protection equipment and other components.

1.3.3 VSC Unit

Three VSC phase units, together with VSC unit control equipment, essential protective and switching devices and auxiliaries, if any, used for conversion.

1.3.4 VSC Substation

Part of a VSC Transmission scheme, consisting of one or more VSC unit(s) installed in a single location together with buildings, VSC dc capacitors, reactors, transformers, filters, control, monitoring, protective, measuring and auxiliary equipment, as applicable.

1.3.5 Two-Level Converter

A converter in which the voltage at the ac terminals of the VSC unit is switched between two discrete dc voltage levels.

1.3.6 Three-Level Converter

A converter in which the voltage at the ac terminals of the VSC unit is switched between three discrete dc voltage levels.

1.3.7 Multi-Level Converter

A converter in which the voltage at the ac terminals of the VSC unit is switched between more than three discrete dc voltage levels.

1.3.8 VSC Pulse Number p

Characteristic of a VSC unit connection expressed as the number of non-simultaneous symmetrical commutations occurring during one cycle of the ac line voltage, assuming the valves in each VSC unit are controlled to achieve full wave rectification/inversion.

1.4 VSC UNIT EQUIPMENT

1.4.1 VSC Valve

Complete operative controllable valve device assembly, including its free wheeling diode, which can function as part of a VSC phase unit.

1.4.2 Diode Valve

Complete operative valve device assembly, comprised of diodes, which may be used in some VSC units.

1.4.3 VSC Valve Level

Part of a VSC valve comprised of a controllable switch and a diode, or controllable switches and diodes connected in parallel, together with the immediate auxiliaries and reactor, if any.

1.5 VSC SUBSTATION EQUIPMENT

1.5.1 Interface Transformer

Transformer through which power is transmitted between the ac system connection point and one or more VSC units.

1.5.2 Phase Reactor

A reactor series-connected directly to the ac terminal of the VSC phase unit.

1.5.3 VSC DC Capacitor

Capacitor bank(s) which sustain the direct voltage for the operation of the voltage sourced converter. The capacitors may be connected between the dc terminals of a VSC unit or within the VSC unit.

1.6 REFERENCES

[1-1] *Terminology for high-voltage direct current (HVDC) transmission*, IEC 60633, October 1998.

2. VSC TRANSMISSION APPLICATIONS

2.1 INTRODUCTION

The advantage of HVDC transmission has been proven since 1954, when the first commercial link from the mainland of Sweden to the island of Gotland was commissioned. The early HVDC schemes used mercury arc valve technology, but this has now been replaced by thyristor valves because of the superiority of the thyristor technology. With these types of converter switches, the conversion from ac to dc and vice versa depends on an ac voltage for the commutation process. For satisfactory operation, a relatively strong ac system with a sufficiently high short-circuit power is necessary. These converters are called line commutated converters, and HVDC transmission using this technology is referred to in this report as LCC HVDC.

Voltage sourced converters (VSCs) have been used for many years in motor drives. The application of VSCs to HVDC transmission, however, is new and has only been a reality since 1997, when the concept of VSC Transmission was announced for medium power dc transmission. Several schemes are now in operation. At the end of 2004 the largest VSC Transmission installation was the Cross Sound Cable between Connecticut and Long Island, New York. Commissioned in 2002, it has a capacity of 330 MW using a transmission voltage of ± 150 kVdc. Appendix A gives a list of VSC Transmission schemes in service or under construction at the end of 2004.

The thyristor valve used for the conversion in LCC HVDC can only switch off when the current through it passes zero, and hence relies on the line voltage for commutation (line commutated converter). In contrast, the voltage sourced converter is based on controllable semiconductor switches, meaning that the valves can be switched on and off by external low-voltage control signals independently of the main current passing through the valve. This difference in operation gives VSC Transmission significant advantages over LCC HVDC, since the VSC can function when it is connected to an ac system with a very low short-circuit ratio, or even to passive a ac system without any generation or short-circuit power.

In addition, a significant distortion in the ac voltage waveshape can lead to a commutation failure for an LCC HVDC scheme, causing a short and temporary interruption in power flow. Because the VSC is self-commutating, it does not suffer from such commutation failures.

However, the VSC has diodes connected in anti-parallel to the IGBTs, and in the event of a fault on an overhead dc line, the VSC at both ends must be disconnected by opening the ac circuit breakers and enabling the arc to extinguish. In such a circumstance, an LCC HVDC converter would suffer a shorter interruption, since the valves can automatically block to stop the direct current flow and extinguish the arc without opening the breakers. This ensures the fast recovery of the LCC HVDC scheme in case of transient faults in the dc grid.

Because modern semiconductors, such as IGBTs, can be switched on and off several times each power frequency cycle, it is possible with switching techniques to produce an output waveshape that will eliminate low order harmonics. The drawback is that these switching operations cause power losses that increase with the switching frequency. However, the better wave shape means that harmonic filtering is easier for VSC Transmission than for LCC HVDC, rendering large switchable harmonic filters unnecessary. As a consequence, the footprint of a VSC scheme is much smaller than for an LCC HVDC scheme of the same rating.

LCC HVDC and VSC Transmission are compared in Chapter 14.

2.2 EXAMPLES OF POSSIBLE VSC TRANSMISSION APPLICATIONS

The excellent characteristics of VSC Transmission are very promising for a wide range of possible applications, such as the following:

- Point-to-point schemes—overhead lines
- Point-to-point schemes—cables
- In-feeds to city centres
- Transmission to/from weak ac systems
- Back-to-back schemes
- In parallel with an existing LCC HVDC link, for increase of transfer capability
- Enhancement of an ac system
- As a parallel link to ac transmission lines, to reduce bottlenecks in transmission networks
- DC land cable systems
- DC transmission cables in areas where it is impossible to obtain permission to build overhead lines
- Multi-terminal systems
- Interconnections of asynchronous power systems
- Supply of loads in isolated areas
- Connection to wind farms (onshore or offshore) or wave power generation
- Supply to and from offshore loads/platforms

In instances where a VSC Transmission scheme supplies a local ac system with low generation and mechanical inertia, and the VSC Transmission supply is dominant compared with local generation, the sending and receiving end ac systems should be checked for stability.

2.3 THE VOLTAGE SOURCED CONVERTER AS A BLACK BOX

The operation of a voltage sourced converter is described in greater detail in Chapter 3. In this chapter the converter is treated as a black box that can convert from ac to dc and vice versa, and only steady-state operation is considered.

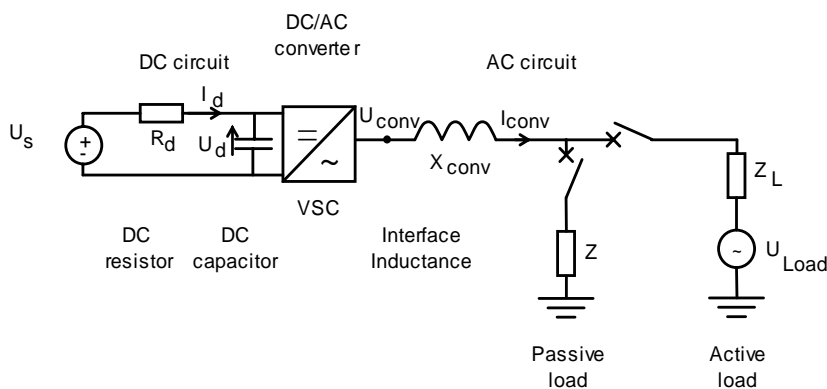

Figure 2.1: Diagram of a generic voltage sourced converter

Figure 2.1 depicts a schematic diagram of a generic voltage sourced converter connected to a dc circuit on one side and to an ac circuit on the other.

The VSC can be operated as either an inverter, injecting real power into the ac ac system ($I_d \times U_d > 0$), or as a rectifier absorbing power from the ac ac system ($I_d \times U_d < 0$). Similarly, the VSC can be operated either capacitively, injecting reactive power into the ac ac system ($j I_{conv} \times U_{conv} > 0$), or inductively, absorbing reactive power from the ac ac system ($j I_{conv} \times U_{conv} < 0$). The VSC can be operated capacitively or inductively in both the inverter and the rectifier mode.

The designation voltage sourced converter is used because the function of the VSC is predicated on the connection of a voltage source on the dc side.

To the left in Figure 2.1, a dc voltage source U_s is shown with a dc resistor R_d representing the dc circuit resistance, and a dc capacitor connected across the dc terminal of the VSC. The dc shunt capacitor serves the purpose of stabilising the dc voltage U_d . The conversion from dc to ac takes place in the VSC as explained in Chapter 4. On the ac side, an interface inductance is provided which serves two purposes: First, it stabilises the ac current, and secondly, it enables the control of active and reactive output power from the VSC, as explained in Section 2.4. The interface inductance can be implemented as phase reactors, as leakage inductances in transformers, or as a combination thereof. The dc capacitor on the input side and the ac interface inductance on the output side are important components for the proper functioning of a VSC.

A passive or active ac ac system can be connected on the ac side of the VSC. If the VSC is connected to a passive ac system on its ac side, the power flow can be only from the dc input side towards the passive load on the ac side. However, if the ac side is connected to an active ac ac system, the power flow can be in both directions by controlling the ac voltage output U_{conv} of the VSC.

By controlling the phase angle of U_{conv} , the active power through the VSC can be controlled as explained in Section 2.4.1. By controlling the voltage amplitude of U_{conv} , the reactive power through the VSC can be controlled, as explained in Section 2.4.2.

2.4 THE PRINCIPLES OF ACTIVE AND REACTIVE POWER CONTROL

The VSC can be considered as an equivalent of a synchronous generator without mechanical inertia, which has the capability of individually controlling active and reactive power.

The exchange of active and reactive power between a VSC and the ac system is controlled by the phase angle and amplitude of the VSC output voltage in relation to the voltage of the ac system.

The active and reactive power can be controlled simultaneously and independently of each other. If U_{conv} is in phase with the line voltage U_L and its amplitude is equal to U_L , there is no ac current I_{conv} from the VSC. Under these conditions, the dc current I_d becomes zero and the dc capacitor voltage U_d becomes equal to the dc source voltage U_s .

2.4.1 The Principle of Active Power Control

The principle of active power control is depicted in Figure 2.2, where the active power through the interface inductance is controlled by regulating the VSC voltage angle.

If the angle of the VSC output voltage leads the ac system voltage, the VSC will inject active power to the ac system, i.e., it operates as an inverter. On the dc side, an equivalent current will be drawn from the dc source and the voltage U_d will decrease in accordance with Ohm's law ($U_d = U_s - R_d \cdot I_d$).

If, on the other hand, the VSC output voltage lags the voltage of the ac ac system, the VSC will absorb active power from the ac ac system, i.e., it operates as a rectifier. On the dc side, an equivalent current will be injected in the dc source and the voltage U_d will increase in accordance with Ohm's law ($U_d = U_s + R_d \cdot I_d$).

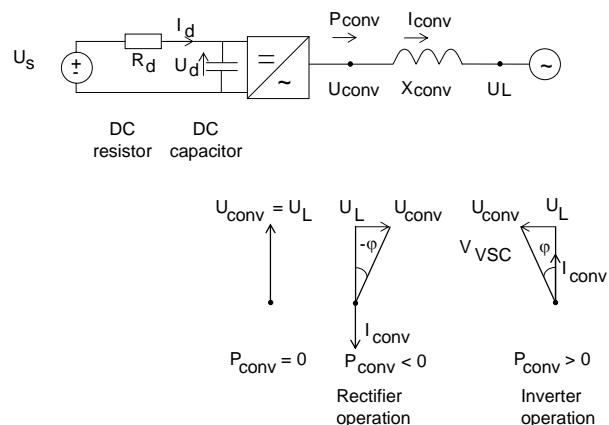

Figure 2.2: The principle of active power control

If the VSC is connected to a passive load, an ac output current will be drawn from the VSC determined by Ohm's law $I_{conv} = U_{conv}/Z$. Again, an equivalent dc current will be drawn from the source and the voltage U_d on the dc capacitor will drop to a value determined by Ohm's law. No active power can be drawn from the ac side, because it is a passive ac circuit.

2.4.2 The Principle of Reactive Power Control

The principle of reactive power control is depicted in Figure 2.3, where the reactive power through the interface inductance is controlled by regulating the amplitude of the VSC output ac voltage.

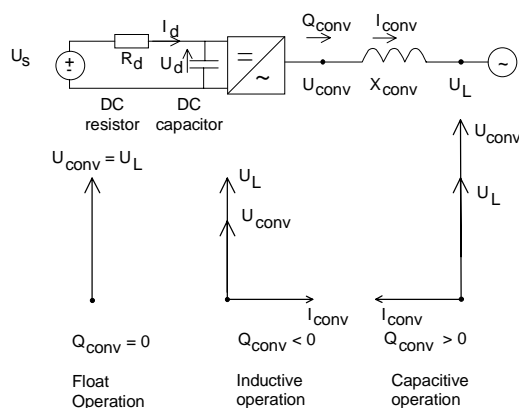

Figure 2.3: The principle of reactive power control

If the amplitude of the VSC output voltage U_{conv} is higher than the ac ac system voltage U_L , the VSC will inject reactive power in the ac ac system, i.e., will operate in the capacitive mode. If the amplitude of the VSC output voltage is lower than the ac ac system voltage, the VSC absorbs reactive power from the ac ac system, i.e., the inductive operating mode.

2.4.3 Basic PQ Diagram for a VSC Station

The PQ capability diagram of a VSC shows its possible operating regime. The diagram normally gives the capability at the ac interface point. When active output power P is positive, the VSC is operated as an inverter, either in capacitive mode, when Q is positive, or in inductive mode when Q is negative. When P is negative, the VSC is operated as a rectifier, either in capacitive or inductive mode. A simplified PQ diagram at minimum (U_{min}) and maximum (U_{max}) ac ac system voltage, in which filters

are not considered, is shown in Figure 2.4. The VSC can be operated within all four quadrants of the PQ plane.

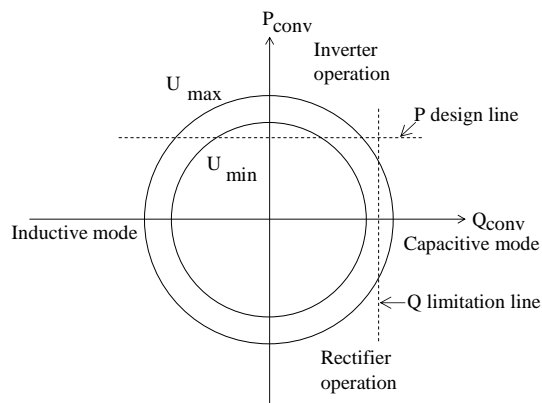

Figure 2.4: A basic simplified PQ diagram

The PQ diagram shows that the VA capability of the VSC depends on the ac system voltage. At the rated current capability of the converter and at minimum ac system voltage, the circular locus identified as U_{min} represents the limit of VA capability of the VSC. The circular locus identified as U_{max} represents the potential increase of capability, which would be available at maximum ac system voltage. The increased output requires an increase of U_{conv} and correspondingly of dc voltage, the operation at maximum capacitive output demands the greatest dc voltage. However, operation at maximum capacitive output demand and at maximum ac system voltage would be an extremely unusual requirement for a VSC. The Q limitation line indicates how the maximum dc voltage on the storage capacitor would impose a limit to the available capacitive output. Note that the centre of the circles is dependant on the design of the converter, and may not be at the origin of the diagram.

The diagram also indicates an active power design line (P design) corresponding to the desired rated power of the VSC. In the example shown, the required power capability in inverter operation is less than the potential capability of the VSC

The PQ characteristics depend on the ac voltage U_{conv} . Therefore, if an interface transformer is provided, the transformer ratio can be used to optimise the PQ characteristic. With an on-load tap changer, the transformer ratio can be continuously optimised to maximise the steady-state power capability of the converter. An additional benefit of a tap changer is that it can minimise the power losses of the VSC Transmission system.

2.5 OPERATING PRINCIPLES OF A VSC TRANSMISSION SCHEME

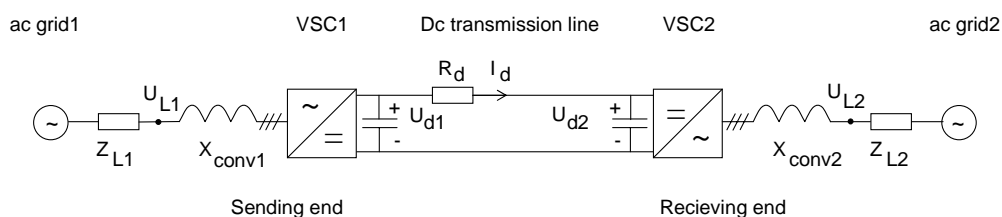

Figure 2.5: A point-to-point VSC Transmission scheme

The point-to-point VSC Transmission scheme shown in Figure 2.5 consists of two VSCs interconnected on the dc side via a dc transmission line and connected to two different ac systems on the ac side. The basic characteristics of a VSC have been described in the previous sections. One of these characteristics is that the dc voltage polarity is always the same. Therefore, the direction of the power flow on the dc line is determined by the direction of the dc current. In Figure 2.5 the current flow and the power flow are from VSC1 (the sending or rectifier end) to VSC2 (the inverter or receiving end) of the dc line.

The direction of a dc current is always from a higher dc voltage level to a lower dc voltage level. The dc voltage at the sending end of the dc line must therefore be higher than dc voltage at the receiving end. The value of the current is determined by Ohm's law, as the voltage difference between sending and receiving ends divided by the resistance in the dc line $I_d = (U_{d1} - U_{d2}) / R_d$.

In LCC HVDC, the dc line power flow can be controlled by holding the dc voltage at the receiving end converter (the inverter) at a constant value, and by letting the sending end converter (the rectifier) control the dc current. The same approach can be used in VSC Transmission. However, one main difference is that in LCC HVDC the current direction is always the same; therefore, the power direction is changed by changing the dc voltage polarity.

2.6 LOSSES

VSC Transmission has higher losses than LCC HVDC . This is obviously an economic disadvantage for VSC Transmission in bulk power transmission, since its capitalised losses are comparatively high.

However, the technical advantages of VSC Transmission can offer other system benefits, such as ancillary services like ac voltage support or black network start. VSC Transmission is also well suited for use in a liberalised market where rapid and frequent power transmission changes in both directions can be expected. For such applications, it is important to accurately assess transmission losses under realistic operating conditions when comparing LCC HVDC and VSC Transmission.

In general, losses can be divided into no-load losses and load losses. The no-load losses are those that arise when the VSC Transmission is energised without any power being transmitted, and when no reactive power is exchanged between the VSC stations and the ac system.

No-load losses primarily arise in interface transformers, phase reactors and filters as iron or dielectric losses. In addition, various auxiliary systems, such as cooling, heating and power supply to the control system, also contribute to these losses when the VSC stations are energized.

The load losses occur when power is being transmitted and the VSC stations are exchanging reactive power with their ac systems. Load losses increase with the loading of the dc transmission line and the VSC stations. The load losses arise from ohmic conduction losses in the dc lines and in the VSC stations. Load losses in the VSC station come from ohmic conduction losses, and from switching losses in the semiconductor switches and their anti-parallel diodes, and in snubber circuits, if any.

For an accurate capitalisation of the losses, as described in Chapter 13, it is crucial to know the no-load and load losses as a function of power transmission and reactive power exchange with the ac system. Based on this information, as well as on the expected use and loading of the VSC Transmission scheme (e.g., as a load duration curve over a year), it is possible to capitalise losses.

2.7 SUMMARY OF THE BASIC CHARACTERISTICS OF VSC TRANSMISSION

Although VSC Transmission possesses several inherent technical advantages over LCC HVDC, it should be emphasised that some functionalities similar to those of VSC may be obtained with an LCC if special measures and design are implemented in the scheme. For instance, it is possible to design an LCC HVDC scheme for operation at extreme low short-circuit ratio (SCR), particularly if the installation is supplemented by synchronous condensers for voltage control and additional mechanical inertia in the ac systems. This would, however, add losses and costs to an LCC HVDC solution

The advantages and disadvantages of VSC Transmission compared with LCC HVDC are summarised as follows:

VSC Advantages Compared with LCC

- The VSC valves are self-commutating.
- Commutation failures due to ac system fault or ac voltage dips do not occur.
- The VSC may be operated at a very small short-circuit ratio. The least SCR which has been practically experienced by the end of year 2004 is 1.3.
- The VSC can energise a passive or dead ac system.
- VSC Transmission has no minimum dc current limits.
- The reactive power, either capacitive or inductive, can be controlled independently of the active power within the rating of the equipment.
- Reactive shunt compensation is not required.
- Only harmonic filters are needed, and they need not be switchable.
- Depending on the converter topology, if transformers are needed they do not have to be specially-designed HVDC converter transformers, but conventional ac transformers may be used.
- The voltage polarity on the dc side is always the same. DC cables are always exposed to the same voltage polarity.
- The VSC control can be designed such that the VSC stations can eliminate flicker and selected harmonics in the ac system.
- The VSC stations can be operated as STATCOMs, even if the VSC is not connected to the dc line.
- The footprint of a VSC station is considerably smaller than an LCC HVDC station.
- Inherently, VSC Transmission can operate without telecommunication between the VSC substations.

VSC Disadvantages Compared with LCC

- At the end of year 2004, practical experience with VSC Transmission was not as extensive as with LCC.
- The maximum VSC Transmission ratings are +/- 150 kV and 350 MW (receiving end). For higher transmission capacities, additional parallel VSC Transmission schemes would be required, which would add costs and losses to a VSC solution.
- DC line faults require opening of the VSC ac circuit breakers at both ends of a scheme in order to clear the dc fault, unless appropriate dc breakers are provided in the scheme.
- The switching losses in the VSC valves are higher compared with similar LCC valves, primarily due to higher switching frequency, and because a VSC valve has many more semiconductor switches than an LCC valve of the same rating.

Today, the main obstacles to VSC Transmission are its high losses and limited capacity for bulk power transmission.

2.8 REFERENCES

- [2-1] Eek, J., Pedersen, K.O.H., Sørensen, K., "Development and testing of ride-through capability solutions for a wind turbine with doubly fed induction generator using VSC transmission." CIGRÉ session paper No. B4-302, Paris, 2004.
- [2-2] Belhomme, R., Joncquel, E., Sørensen, K., Woodford, D., "AC Cable Versus DC Cable Transmission for Offshore Wind Farms, a Study Case." Fourth International ELTRA

- Workshop on Large-Scale Integration of Wind Power and Transmission Networks for Offshore Wind Farms, Billund, Denmark, 2003.
- [2-3] Belhomme, R., Joncquel, E., Sørensen, K., Abildgaard, H., Woodford, D., "The challenge of integrating large-scale offshore wind farms into power systems." CIGRÉ session paper No. 14-204, Paris, 2002.
- [2-4] Eriksson, K., Liljegren, C., Sørensen, K., "HVDC Light experiences for power transmission from offshore wind power parks." ASME/AIAA, Wind Energy Symposium, Reno NV, USA, January 2004.
- [2-5] Eriksson, K., "Operational Experiences of HVDC Light." 7th International IEE Conference on AC-DC Power Transmission, London, UK, November 2001.
- [2-6] Castro, A.D., Ellström, R., Häffner, Y.J., Liljegren, C., "Co-ordination of Parallel AC-DC Systems for Optimum Performance." Power Delivery Conference, Madrid, September 1999.
- [2-7] Sørensen, K.H., Sørensen, P.L., Christensen, P., Andersen, N., Eriksson, K., Holmberg, P., "DC feeder for connection of a wind farm." CIGRÉ Symposium paper No. 500-06, Kuala Lumpur, 1999.
- [2-8] Jing, Y., Ekström, Å., "A comparison study between UPFC and back-to-back stations. *Proceedings, 3rd International Power Engineering Conference, IPEC 97*, Singapore, May 1997.
- [2-9] Larsson, T., Petersson, Å., Edris, A., Kidd, D., Aboytes, F., "Eagle Pass Back-to-Back Tie: A Dual Purpose Application of Voltage Source Converter Technology." IEEE paper 0-7803-7173-9/01, 2001.
- [2-10] Stendius, L., Eriksson, K., "HVDC Light: An Excellent Tool for City Center Infeed." PowerGen Conference, Singapore, September 1999.
- [2-11] Grunbaum, R., "Enhancing of power quality and availability in distribution systems by means of Voltage Source Converters." IEE 16th International Conference and Exhibition on Electricity Distribution, CIRED2001, Conference Publication No. 482, Amsterdam, June 2001.
- [2-12] Bahrman, M.P., Johansson, J.G., Nilsson, B.A., "Voltage source converter transmission technologies—the right fit for the application." IEEE PES General Meeting, Toronto, July 2003.
- [2-13] Toledo, P.F., Söder, L., "Benefits of New Voltage Source Converter HVDC Configurations for City Infeed." 2nd IASTED International Conference, Power and Energy Systems, EuroPES2002, Crete, Greece, June 2002.
- [2-14] Toledo, P.F., Ekström, Å., "Cooperation between line commutated current source converter and forced commutated voltage source converters in HVDC transmission." *Proceedings, 10th European Conference on Power Electronics and Applications, EPE 2003*, Toulouse, France, September 2003.
- [2-15] Karlstrand, J., Bergman, G., Jönsson, H-Å., "Cost-efficient XLPE cable system solution." IEE 7th International Conference on AC-DC Power Transmission, Conference publication No. 455, November 2001.
- [2-16] Lu, W., Ooi, B.T., "Multi-terminal HVDC system for optimal acquisition of power in wind-farm using induction generators." *IEEE Transactions on Power Electronics*, Vol. 17, No. 4, pp. 558-563, July 2002.
- [2-17] Lu, W., Ooi, B.T., "Optimal Acquisition and Aggregation of Offshore Wind-Power by Multi-Terminal Voltage-Source HVDC." *IEEE Transactions on Power Delivery*, Vol. 18, No.1, pp. 201-206, January 2003.
- [2-18] Lu, W., Ooi, B.T., "Multi-terminal HVDC as enabling technology of premium power quality park." IEEE PES Winter Meeting, New York, 2002.
- [2-19] Lu, W., Ooi, B.T., "Multi-terminal DC transmission system for wind-farms." IEEE Power Engineering Society Winter Meeting, Vol. 3, pp. 1091-1096, 2001.

3. BASIC OPERATING PRINCIPLES OF VSC TRANSMISSION

3.1 INTRODUCTION

The VSC Transmission technology described in this report uses self-commutated voltage sourced converters (VSC), in which commutation does not rely on the voltage of the ac network. The VSC valves use solid-state devices, like insulated gate bipolar transistors (IGBT) or other devices with controlled turn-on and turn-off capability. VSC Transmission has a number of technical features that are superior to those of an LCC HVDC scheme.

A simplified one-line diagram of one of the VSC terminals in a VSC Transmission scheme is shown in Figure 3.1. In a point-to-point transmission scheme, the other half of the scheme would be a mirror image about the mid-point of the dc link. The dc link may be a cable or overhead line. In contrast to line commutated dc transmission, the polarity of the dc voltage remains the same at all times, with the dc current being reversed to change the direction of power flow. The different VSC Transmission applications are described in Chapter 2.

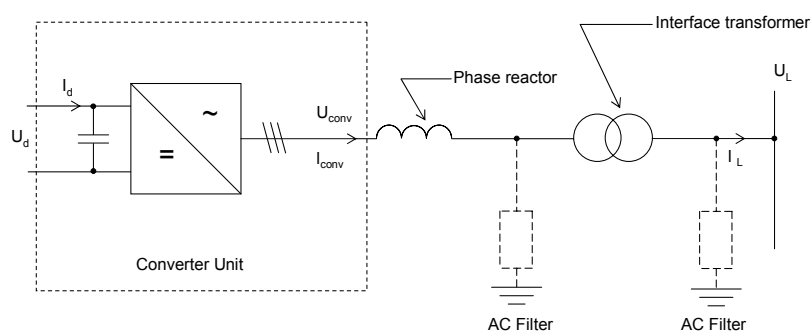

Figure 3.1: One VSC terminal of a VSC Transmission scheme

The VSC approximates a voltage source. The term “voltage source” derives from mathematical circuit analysis and can be defined as: “A voltage source which maintains a prescribed voltage across its terminals, irrespective of the magnitude or polarity of the current flowing through the source. The voltage may be constant dc, sinusoidal ac, a series of pulses, etc. For a prescribed voltage source, the output current depends only on the impedance connected across its terminals.” [3-1].

A VSC has a capacitor connected directly across the dc terminals, with no intervening impedance apart from snubbers and wiring. For short-time transients, a capacitor can be regarded as a voltage source, hence this capacitor represents an approximate dc voltage source. The switching devices are controlled to interconnect the dc and ac terminals in a time sequence such that an ac source of the same type as the dc source is produced. Thus, a VSC produces a quasi-square wave ac voltage.

The basic operating mechanism of an ideal VSC is covered in this chapter. The description is initially limited to a 2-level VSC in square wave operation. The 2-level VSC is the simplest structure needed to convert a dc voltage into ac voltages. Although other types of multi-level VSCs are more complex, their basic operating principle does not differ from that of the 2-level VSC. The different multi-level converter topologies are discussed further in Chapter 4.

For the purpose of illustration, the VSC valves are described as ideal switches without any switching losses. A VSC valve in a real application consists of a large number of series-connected semiconductor devices, and is described in greater detail in Chapter 5. The stray inductances are neglected here, and the dc capacitors have been assumed to have infinite capacitance—i.e., no dc voltage ripple is shown.

The output of the VSC should be connected in series with a phase reactor, as shown in Figure 3.1. The phase reactor enables the VSC to control power flow in addition to smoothing the output current. VSC components are further explained in Chapter 6.

3.2 BASIC OPERATIONAL PRINCIPLE OF TWO-LEVEL CONVERTERS

The basic ac output waveform of a VSC is determined by the topology of the converter. The operating principle of a 2-level VSC is described in the following paragraphs.

A schematic of one-phase of a 2-level converter is presented in Figure 3.2. As shown, it is capable of generating the two voltage levels. In order to improve the quality of the output voltage, pulse width modulation (PWM) (see Chapter 9.3) can be used to produce an output waveform with dominant fundamental component, but also high-order harmonics, as described among others in [3-2] and [3-3].

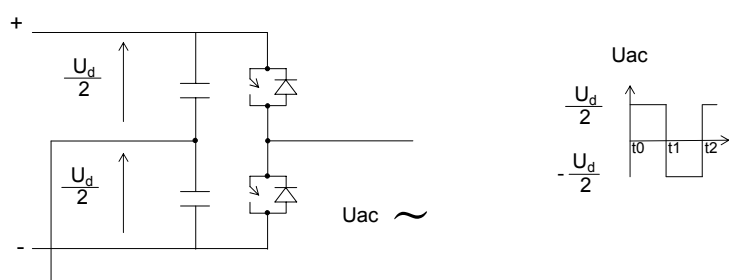

Figure 3.2: Basic operational characteristic of a 2-level VSC

In a real VSC, the switches are implemented as solid-state switches and the voltage source input characteristic is obtained by connecting two dc capacitors in series, as shown in Figure 3.2.

The solid-state switches are unidirectional only, therefore free-wheeling diodes are connected across the solid-state switches, which are shown in the diagram as ideal unidirectional switches. The midpoint of the capacitors can be considered as the reference point for the ac output voltage of the phase unit $U_{ac} = U_{conv}$. The output terminals can only be connected at two voltage levels: the positive dc voltage $+U_d/2$, or the negative dc voltage $-U_d/2$, therefore this is called a two-level converters.

Thus the direct voltage in Figure 3.2 can only have one polarity due to the free-wheeling diodes, whereas the current can flow in both directions.

The four possible current paths in a single-phase, 2-level VSC are shown in Figure 3.3 a,b,c,d. The output current can either be negative or positive. Positive current direction in the VSC is defined as current flowing from the dc side to the ac side (refer to Figure 3.3b and 3.3d).

If the upper VSC valve is on, the output voltage is $+U_d/2$. If the current is negative (Figure 3.3a), the current path is through the upper free-wheeling diode, because the controllable switch can only conduct current in the downward direction. If the current is positive (Figure 3.3b), the current path is through the upper controllable switch.

If the lower VSC valve is on, the output voltage is $-U_d/2$. If the output current is negative, the current path is through the controllable switch (Figure 3.3c), and if the current is positive, its path is through the lower free-wheeling diode (Figure 3.3d).

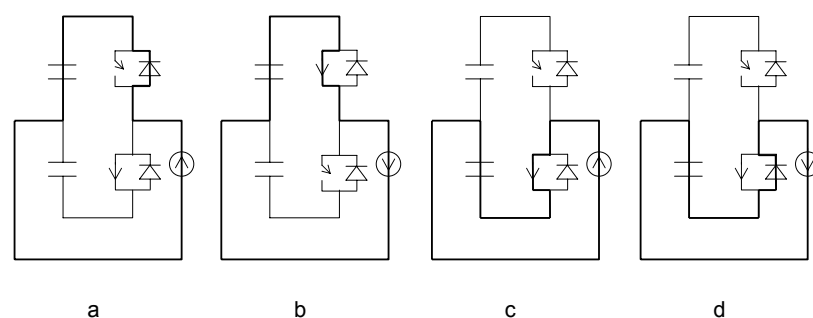

Figure 3.3: The four possible current paths in a single-phase, 2-level VSC

The following paragraphs describe in more detail the basic operation of the 2-level VSC shown in Figure 3.2.

Assuming both switches are blocked, i.e., with open switches, the free-wheeling diodes form an uncontrolled rectifier. An external ac voltage source applied as U_{ac} would charge the two dc capacitors via this rectifier to the peak value of the ac voltage $U_{dc}/2 = \sqrt{2} U_{ac}$ across the upper and lower dc capacitor, with polarities as shown in the figure. With the dc capacitors charged and the external source connected, the VSC is ready for operation.

The controllable switches can be switched on and off in a desired pattern via the gate signals. During operation, one switch is turned on while the other is turned off. Turning on both controllable switches at the same time would create a short circuit of the dc capacitors, and must be prevented. In order to avoid such a short circuit, the controllable switch in the off-state is turned on shortly after the controllable switch in the on-state is turned off. This creates a short instant, called the “blanking time,” when none of the controllable switches are on. During a typical blanking time of some 10 microseconds, a current path is provided by the free-wheeling diodes.

Assuming the upper switch is turned on at $t = 0$, as shown in Figure 3.2, the ac terminal would be connected to the plus terminal of the storage capacitor, resulting in a current flow through the upper switch. Depending on the pulse pattern applied, the upper switch will be turned off after a short time span at $t = t_1$. However, the source impedance of the external ac circuit, which in most cases will be the impedance of the interface transformer and/or phase reactor (see Figure 3.1), will maintain the present current. Thus, the diode connected in parallel to the lower switch turns on. As a consequence, the voltage U_{ac} changes from plus to minus $U_{dc}/2$. The polarity reversal is initiated by turning off the switch actively, i.e., while it carries current.

The lower controllable switch is required to be on whenever the current reverses, to maintain the voltage polarity, and therefore it will get a gate signal following a very short blanking time, typically some 10 microseconds after blocking the upper VSC valve. The lower controllable switch will then take over current as soon as the current reverses its direction, which depends also on the impedance of the interface transformer and the phase reactor, as well as the ac system voltage.

Assume now that during PWM operation, the current is still flowing in the diode parallel to the lower switch, when at $t = t_2$ it is required to connect the converter ac terminal to the positive terminal of the VSC dc capacitor again. The first action that needs to be taken is to turn off the lower switch, since it must be blocked before the upper switch can be turned on. However, this will not affect the current at all, as it is still flowing through the diode. In the next step, the upper switch can be turned on after the short blanking time mentioned above. Turning on the upper switch creates a temporary current path from the VSC dc capacitors through the upper switch and the lower diode back to the VSC dc capacitors. The current flowing in this circuit will extinguish the current in the diode, which will block automatically and leave the upper switch as the only current-carrying device. Turning on the upper switch has resulted in the blocking of the lower diode and thus caused the desired voltage polarity reversal at U_{ac} .

The two mechanisms, turning on and off the switches of the VSC phase unit actively in an alternating manner, entirely determine the switching states of the diodes and therefore the voltage level on the ac terminal. This basic principle of operation can be found in all types of VSCs, and applies irrespective of any fundamental power flow (in all four quadrants, active power export or import, as well as capacitive or inductive reactive power). Therefore, the VSC can be represented in a simplified manner as a voltage source with the magnitude and the phase angle of the ac voltage U_{ac} determined by the dc voltage and the pulse patterns. This is further described below, where the VSC in a three-phase configuration is presented.

3.3 TWO-LEVEL VSC—THREE-PHASE CONFIGURATION

The basic 2-level voltage sourced converter described above is illustrated in a three-phase (phase a,b,c) configuration in Figure 3.4. Each of the six VSC valves consists of one switching unit with a current turn-on and off capability and a free-wheeling diode.

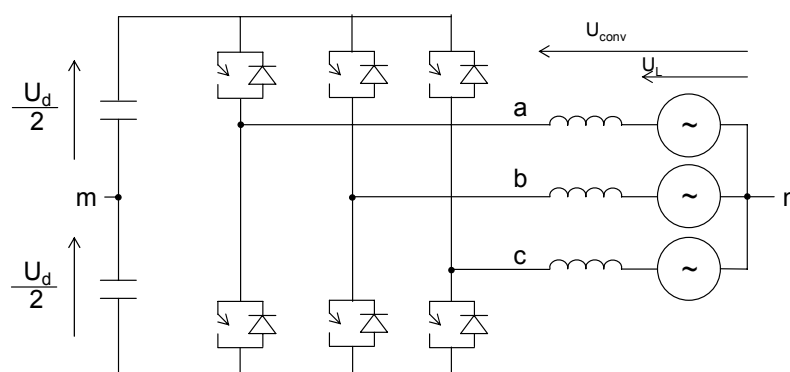

Figure 3.4: The basic 2-level, 6-pulse VSC—three-phase configuration

3.3.1 Terminal Voltages

The simplest operational mode for the 2-level VSC is the square wave operation. Figure 3.5 presents the terminal voltages on the valve side of the station transformer winding for a VSC in square wave operation. The first three sets of curves are the voltages between phase terminals and the midpoint “m” of the dc capacitors. The next three are the line-to-line voltages between the terminals. The last curve is the phase voltage in phase a.

As can be seen, each valve switches on and off once each cycle of the ac voltage, thus giving rise to six pulses per fundamental frequency period, as shown.

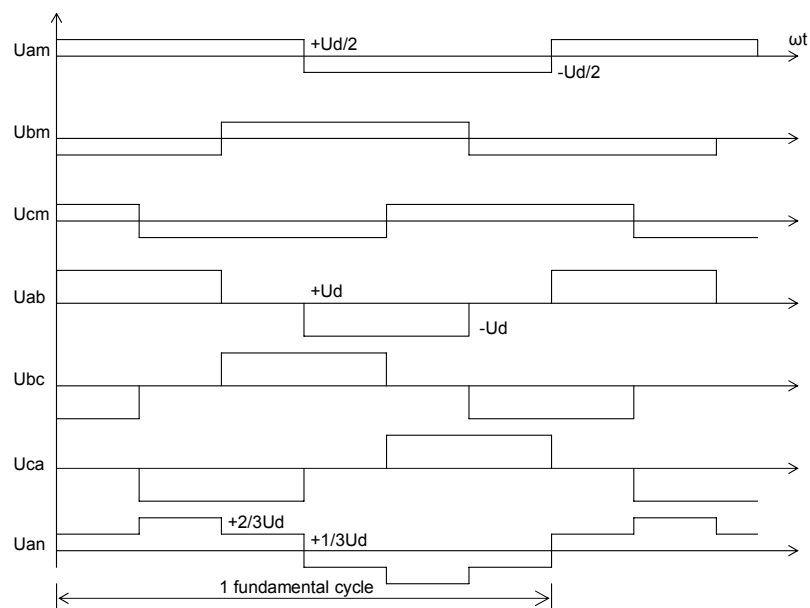

Figure 3.5: VSC voltages converter side—square wave operation

- Curve 1,2,3: Phase-terminals (a,b,c) to midpoint m
- Curve 4,5,6: Terminal line-to-line voltage (a-b,b-c,c-a)
- Curve 7: Phase voltage terminal a to neutral

3.3.2 Fundamental Frequency Equations—Square Wave Operation

The VSC square wave operation can be represented with an equivalent circuit [3-3], as shown in Figure 3.6. In this equivalent, the converter voltage $U_{conv\ ph}$ in Figure 3.6 is equivalent to U_{an} in Figure 3.5. The filters shown in Figure 3.1 are neglected for simplicity, hence I_{conv} in Figure 3.6 equals I_L in Figure 3.1. The reactance X represents both the interface transformer and phase reactor reactance. The resistance is neglected for simplicity. The ac voltage U_L is used as the phase angle reference.

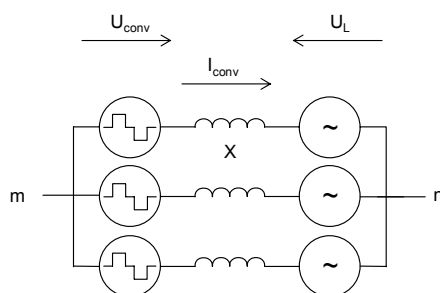

Figure 3.6: Equivalent circuit VSC

The r.m.s. value of the fundamental frequency component of the phase voltage $U_{Conv-ph}$ on the valve side of the interface reactance for the VSC in square wave operation can then be defined as [3-3]:

$$U_{conv,ph(1)} = \frac{\sqrt{2}}{\pi} k_\lambda U_d e^{-j\delta} \tag{Equation 3.1}$$

The relationship between the r.m.s. value of the fundamental frequency component of the line-to-line voltage on the valve side of the interface reactance and the dc voltage can be expressed as [3-3]:

$$U_{conv(1)} = \frac{\sqrt{6}}{\pi} k_{\lambda} U_d e^{-j\delta} \quad \text{Equation 3.2}$$

Where

δ is the phase angle between the converter voltage U_{conv} and the ac voltage U_L
 k_{λ} is the voltage ratio factor [0..1]

Equation 3.1 includes the voltage ratio factor k_{λ} as shown. For square wave operation k_{λ} equals 1. For a PWM converter k_{λ} equals any value between zero and 1.

By neglecting the resistance the corresponding phase current in phase a can be expressed as:

$$I_{conv.a(1)} = \frac{U_{conv.ph(1)} - U_{L(1)}}{Z} = \frac{\frac{\sqrt{2}}{\pi} k_{\lambda} U_d e^{-j\delta} - U_{L(1)} e^{-j0}}{jX} \quad \text{Equation 3.3}$$

Corresponding current expressions are obtained for the other phases.

3.4 ACTIVE AND REACTIVE POWER EQUATIONS

Electrical engineering textbooks give the equation for transmission across a system with known series impedance and known sending end and receiving end voltages. By neglecting the resistance and expressing the voltages by line-to-line voltages, the following expressions for P and Q can be derived [3-3]:

$$P = \frac{U_{conv(1)} \cdot U_{L(1)}}{X} \sin \delta \quad \text{Equation 3.4}$$

$$Q = \frac{U_{L(1)} (U_{L(1)} - U_{conv(1)} \cos \delta)}{X} \quad \text{Equation 3.5}$$

The direct current of the converter bridge I_d can also be derived from the equality of power on the ac and the dc side [3-3]:

$$I_d = \frac{\sqrt{6}}{\pi} \frac{U_{L(1)}}{X} \sin \delta \quad \text{Equation 3.6}$$

As can be seen from Equation 3.4, the active power is mainly determined by the phase angle between $U_{L(1)}$ and $U_{conv(1)}$. At any given operating point, an increase of the phase delay of $U_{conv(1)}$ would result in a relative decrease in the active power delivered to the ac system. Similarly, at any given operating point, a decrease of the phase angle delay of $U_{conv(1)}$ would result in a relative increase in the active power delivered to the ac system.

In normal operation, the dc voltage will be approximately constant, whereas the dc current will vary in both magnitude and direction. The output active power of the VSC link will, therefore, be proportional

to the average input dc current both in magnitude and direction. A change of active power direction for a VSC is achieved by changing the direct current direction.

The reactive power for the VSC (as shown in Equation 3.5) is mainly determined by the magnitude of the converter side ac voltage $U_{\text{conv}(1)}$ relative to $U_L(1)$. At any given operating point, an increase of $U_{\text{conv}(1)}$ would result in a relative increase in the reactive power delivered to the ac system. Similarly, at any given operating point, a decrease of $U_{\text{conv}(1)}$ would result in a relative decrease in the reactive power delivered to the ac system.

As described in Chapter 2, one of the great advantages of VSC Transmission is that it can operate in all four quadrants in the P-Q diagram. This implies that the VSC can generate and absorb reactive power independently of dc link power magnitude and direction.

3.5 VSC CONTROL AND HARMONICS

There are limitations in terms of the performance for a 2-level fundamental frequency-switched converter. As a consequence such control is not widely used in practice.

The most commonly used methods to control P & Q in steady state and during dynamics are:

- High frequency switching PWM
- Multi-level
- Combination of the above

By using PWM, it is possible to achieve fast control of the converter ac voltage and, at the same time, keep the dc voltage constant. PWM is further described in Chapter 7. The multi-level converter is described in Chapter 4.

By increasing the switching frequency, the harmonic distortion at the ac system connection is moved to higher orders, which are easier to filter. However, increasing the switching frequency also increases losses, as further described in Chapter 5. Therefore, an optimisation has to take place in order to balance the harmonic level, on the one hand, and the capital cost, power losses, footprint, etc., on the other.

The converter output voltage can only vary between a limited number of voltage levels. Therefore, in order to obtain a reasonable sinusoidal voltage at the ac system connection, output filters would normally be needed in accordance with specified harmonic requirements. Similarly, to satisfy the respective ac system requirements, ac harmonic filters may be needed to limit the harmonic currents that can flow into the ac system.

Typically, low-order harmonics require filters with a higher fundamental frequency rating than those used for filtering higher-order harmonics. The low-order harmonic content in the voltage output of a VSC can be reduced in different ways. Harmonics are covered in greater detail in Chapter 9.

3.6 REFERENCES

- [3-1] EPRI Research Project 2443-5, EL5332, “*Feasibility of Gate Turnoff Thyristor in a High Voltage Direct Current Transmission System.*” Electric Power Research Institute (EPRI), Palo Alto, California, August 1987.
- [3-2] Mohan, N., Undeland, T.M., Robbins, W.P., *Power Electronics: Converters, Applications and Design.* John Wiley & Sons, Hoboken, NJ, 2003.
- [3-3] Ekström, Å., *High Power Electronics HVDC and SVC.* The Royal Institute of Technology, Stockholm, June 1990.

- [3-4] CIGRÉ WG 14.19, *Static Synchronous Compensator (STATCOM)*, Erimez, I.A., Foss, A.M., eds. SC14. CIGRÉ, August, 2000.
- [3-5] Schettler, F., Huang, H., Christl, N., "HVDC Transmission Systems Using Voltage Sourced Converters: Design and Application." *Conference Proceedings, IEEE Summer Meeting 2000*, Paper No. 2000 SM-260, vol. 2, pp. 716-720.
- [3-6] Lindberg, A., *PWM and Control of Two and Three Level High Power Voltage Source Converters*. The Royal Institute of Technology, Stockholm, 1995.

4. VSC TRANSMISSION TOPOLOGIES

4.1 INTRODUCTION

For a high power VSC Transmission system, the key issue that determines the power circuit structure, and thereby the cost and operating losses of the overall system, is the method used to construct the output voltage waveform. The output voltage waveform should approximate a sine-wave in order to eliminate or minimise the need for harmonic filtering. The switching converter considered for practical implementation is a voltage sourced converter operated with a fixed dc voltage. The converter is an array, or matrix, of controlled solid-state switches which connect the dc input voltage periodically, for pre-determined intervals, to the output to produce the ac output voltage. The converters at each end of a VSC Transmission system can be arranged in a number of different ways, with the configuration of the converter normally being referred to as its topology.

It is a fundamental criterion for any viable topology that it enables the functional requirements to be met. Different topologies have different technical characteristics, and therefore allow the overall scheme to be optimised in different ways. Manufacturers may have different preferred topologies and be able to best optimise their proposals around this preferred topology. It is recommended that customers do not stipulate the topology to be used for a VSC Transmission system, unless there are compelling reasons for doing so.

It is possible to arrange the converters to have a single-, three- or multi-phase ac output/input. For the purpose of this report only the three-phase arrangement will be discussed.

The switch-matrix may be of different complexity depending on the number of “dc” voltage levels to be produced at the ac output of each converter phase unit. As the number of attainable voltage levels increases, the approximation of an ac sinusoidal output is approached at the expense of increasing circuit complexity.

This chapter begins with a description of a number of different arrangements of the commutating switches (VSC valves), referred to as the converter phase unit topology, which may be 2-level, 3-level or multi-level. The chapter then describes how different combinations of the converter phase unit topology can be used to create a converter topology for each terminal of the VSC scheme. The chapter concludes with a brief summary and a comparison of the relative merits of each topology.

A major difference between the application of voltage sourced converters for STATCOM and VSC Transmission is that for VSC Transmission it is necessary to control the two dc bus voltages such that the desired real power flows between the two terminals. In practice this means that the dc bus voltage is kept almost constant in a VSC Transmission system, i.e., there is one less degree of freedom compared to a STATCOM application. In particular, to control the fundamental frequency component of the ac voltage, and thus the power factor of operation, it is necessary to allocate one switching edge per half cycle.

4.2 CONVERTER PHASE UNIT TOPOLOGIES

The basic objective of the converter is to enable energy to be transferred from an ac busbar to a dc busbar and vice versa. Under normal operating conditions the dc bus voltage in a VSC Transmission scheme can be considered to be stiff, due to the dc capacitor, i.e., the voltage between the two terminals does not change substantially during a power frequency cycle. The peak-to-peak amplitude of the steady-state dc capacitor voltage change within a power frequency cycle is known as the voltage ripple. Voltage ripple is normally expressed as a percentage of the dc voltage.

The converter switches (normally called VSC valves) perform the function of connecting the ac bus to the dc terminals. If the connection is direct through two alternately operating switches, the ac bus voltage will change between the voltage levels at the two dc terminals. Such a converter is known as a 2-level converter. In the 2-level converter, each of the VSC valves has to withstand the voltage between the two dc terminals.

If the dc capacitor is subdivided, or additional dc capacitors are added, it is possible to arrange for the ac voltage to move not only to the voltage at the two dc terminals but also to intermediate levels. The number of voltage levels to which the ac bus voltage can be switched will depend on the number of valves and the number of dc capacitor subdivisions or additional dc capacitors. These arrangements are known as 3-level or multi-level converters, depending on the number of voltage levels that can be achieved. The term multi-level refers to a converter phase unit topology where the ac bus can be switched to attain more than three different voltage levels.

In 3-level or multi-level phase unit topologies, the VSC valves do not normally have to be designed for the full dc terminal-to-terminal voltage. For example, in normal operation each valve in a 3-level converter phase unit topology experiences only 50% of the terminal-to-terminal dc voltage. Similarly, in normal operation each VSC valve in an n-level phase unit topology experiences only the terminal-to-terminal dc voltage of the phase unit divided by (n-1).

In the following paragraphs, converter phase unit topologies suitable for VSC Transmission systems will be described in more detail. It should be noted that a considerable research and development effort is being invested in voltage sourced converter technology, so additional suitable topologies will likely become available subsequent to the issue of this report.

4.2.1 Converter Phase Unit Topologies—General Aspects

For each converter phase unit topology a number of issues need to be considered. While the relative importance of each issue may vary with different topologies, a brief discussion of the primary ones will be given here, to avoid having to repeat them later.

VSC valves can be turned on and off more than once per power frequency cycle to reduce the harmonics on both the ac and the dc side. An additional way to reduce the harmonics is to combine the output from several phase units in an appropriate manner. An additional benefit of switching the valves more frequently is that the size of the dc capacitor(s) can be reduced. This is because the dc capacitor is normally sized to lessen the voltage ripple during operation to about 2-10%, and when the valves are switched the current direction in the dc capacitor changes direction, reducing the effective ripple.

The rapid switching of the ac bus voltage between different levels will result in repetitive, high-frequency transient stresses. These stresses must be taken into account in the design of the components for the VSC Transmission system. For a given dc voltage, the transient stresses will vary with the number of switchings per power frequency cycle and the number of intermediate steps (if any) between the two dc terminal voltages. The stresses are normally lower the higher the number of levels in the converter phase unit topology. Wound components are particularly vulnerable to repetitive, high-frequency transient stresses. However, other components must also be examined carefully. For example, high losses in the dielectrics of insulation systems may cause premature ageing, unless the particular stresses are recognised and taken into account at the design stage. The interface transformer may be protected against the stresses by providing a high-frequency blocking filter between the valves and the transformer. Naturally, all of the components of such a filter must be designed with special attention to the high-frequency stresses imposed on them.

The manufacturer will normally determine the number of valve switching operations performed each power frequency cycle through an economic optimisation process. Effectively, more switching operations will result in the following advantages and disadvantages:

Advantages of increased switching operations:

- Simpler and smaller ac (and dc) harmonic filters
- Smaller dc ripple
- Smaller footprint for the VSC substation

Disadvantages of increased switching operations:

- Higher power losses in the converter
- Reduced power capability for each device
- Stresses on wound components increase due to the more frequent application of high dv/dt from the converter

In the following illustrations, in order to keep the figures simple, the waveform for each topology is shown for the case of fundamental frequency switching. However, this operating mode is unlikely to be used for a VSC Transmission scheme. An example of a pulse width modulation (PWM) waveform will be given for the 2-level and the 3-level converter.

4.2.2 Two-Level Converter

A 2-level phase unit is the simplest switching arrangement capable of producing ac output from a dc source in the form of a simple square-wave. A three-phase converter using three 2-level phase units is illustrated in Figure 4.1.

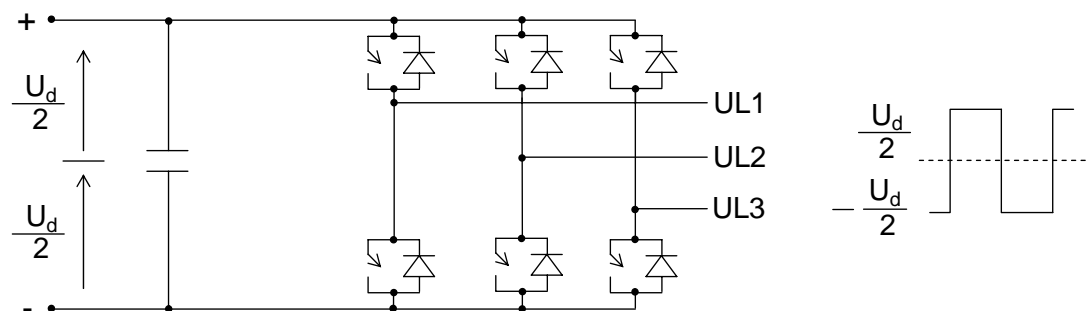

Figure 4.1: Diagram of a three-phase 2-level converter and associated ac voltage waveform for one phase

The ac waveform shown in the figure is the phase-to-neutral voltage, assuming fundamental frequency switching of the phase units. The neutral voltage is the voltage at the midpoint of the dc capacitor.

Due to the square-wave output voltage waveform, the 2-level phase unit is unable to facilitate direct control of the amplitude of its fundamental output voltage without the application of PWM.

A typical PWM-switched waveform, using a carrier based control method with a switching frequency of 21 times the fundamental, is given in Figure 4.2. For the purpose of this illustration, the dc capacitor has been assumed to have an infinite capacitance (i.e., no dc voltage ripple).

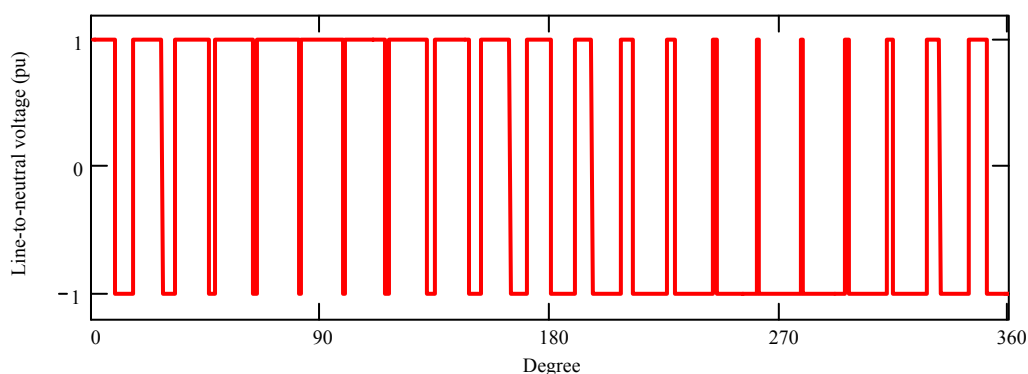

Figure 4.2: Single-phase ac voltage output for 2-level converter with PWM switching at 21 times fundamental frequency

4.2.3 Three-Level Neutral Point Clamped Converter

A three phase converter consisting of three 3-level phase units is illustrated in Figure 4.3. The single-phase output voltage waveform, assuming fundamental frequency switching, is also shown in Figure 4.3. The converter has three dc terminals to connect to a split or centre-tapped dc source. As seen, there are twice as many valves used as in the 2-level phase unit, and additional diodes are required to connect to the dc supply centre-tap, which is the reference zero potential. However, with identical valve terminal-to-terminal voltage rating, the total dc supply voltage can be doubled so that the output voltage per valve remains the same.

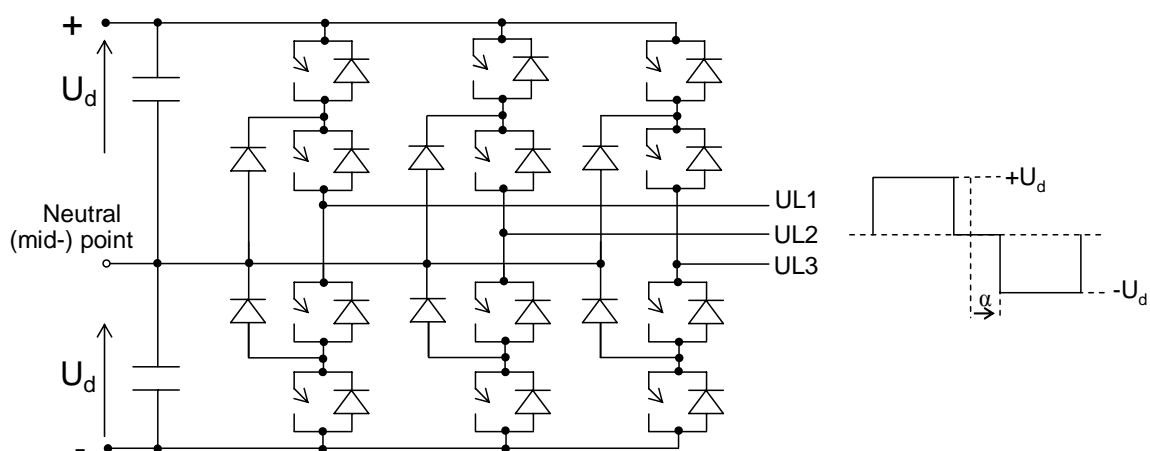

Figure 4.3: Three-phase 3-level NPC converter and associated ac voltage waveform for one phase

The ac waveform shown in the figure is the phase-to-neutral voltage, assuming fundamental frequency switching of the valves. The neutral voltage is the voltage at the midpoint of the dc capacitor. As illustrated in Figure 4.3, the output voltage of the 3-level phase unit can be positive, negative, or zero. Positive output is produced by gating on both upper valves in the phase unit, while negative output is produced by gating on both lower valves. Zero output is produced when the upper and lower middle valves, connecting the centre tap of the dc supply via the two diodes to the output, are gated on. At zero output, positive current is conducted by the upper-middle controllable device and the upper centre-tap diode, and negative current by the lower-middle controllable and the lower centre-tap diode.

As indicated in the figure, the relative duration of the positive (and negative) output voltage with respect to the duration of the zero output is a function of control parameter α , which defines the conduction interval of the top upper, and the bottom lower valves. The magnitude of the fundamental frequency component of the output voltage produced by the phase unit is a function of parameter α . When α equals zero degrees it is maximum, while at α equals 90 degrees it is zero. Thus, one advantage of the 3-level phase unit is that it has an internal capability to control the magnitude of the output voltage without changing the number of valve switchings per cycle.

The operating advantages of the 3-level phase unit can only be fully realised with some increase in circuit complexity, as well as more rigorous requirements for managing the proper operation of the converter circuit. These requirements are related to executing the current transfers (commutation) between the four (physically large) valves, with well-constrained voltage overshoot, while maintaining the required di/dt and dv/dt for the semiconductors without excessive losses.

An additional requirement is to accommodate the increased ac ripple current with a generally high triplen harmonic content flowing through the mid-point of the dc supply. This may necessitate the use of a larger dc storage capacitor or the employment of other means to minimise the fluctuation of the mid-point voltage. However, once these problems are solved, the 3-level phase unit provides a useful building block to structure high power converters, particularly when rapid ac voltage control is needed.

The conduction periods for the inner and the outer valves is different, and therefore it is possible to use two different designs of a VSC valve for the two positions.

By switching the valves more frequently, it is possible to eliminate more harmonics. A typical PWM switched waveform, using a carrier based control method with a frequency of 21 times fundamental frequency, is given in Figure 4.4. For the purpose of this illustration, the dc capacitor has been assumed to have an infinite capacitance (i.e., no dc voltage ripple).

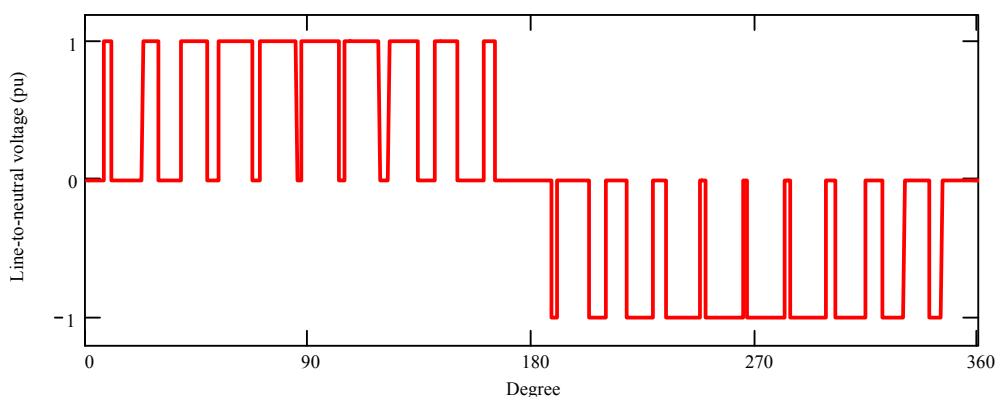

Figure 4.4 Single-phase ac voltage output for 3-level NPC converter with PWM switching at 21 times fundamental frequency

4.2.4 Multi-Level Neutral Point Clamped Converter

In order to further reduce the harmonic content of the ac output voltage, the basic 3-level phase unit can be extended to a multi-level, $2n+1$ phase unit ($n=1,2,3,\dots$) configuration. $2n$ dc supplies, provided by $2n$ dc storage capacitors (which are common to all three-phase units of a complete three-phase converter), are connected in series, providing $2n+1$ discrete voltage levels. Four times n valves are required with $4n-2$ diodes to selectively connect the $2n+1$ voltage levels to the output.

A three-phase converter using 5-level converter phase units with the corresponding single-phase output voltage waveform, in which, as an example, the 3rd, 5th, and 7th harmonics are absent, is shown in Figure 4.5. However, it should be remembered that in practice one degree of freedom would be needed

for control of the amplitude of the fundamental frequency. Therefore, in practice in this example only one of the 5th or the 7th harmonic can be cancelled.

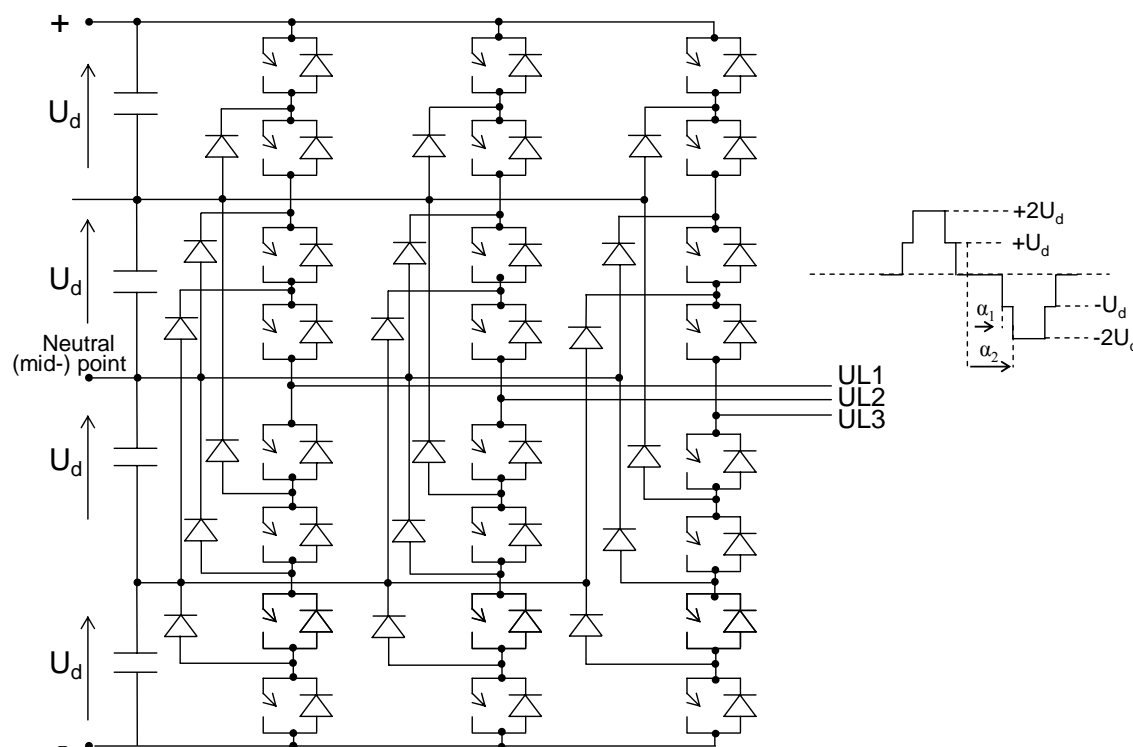

Figure 4.5: Three-phase 5-level NPC converter and associated ac voltage waveform for one phase

From Figure 4.5 it is clear that the circuit complexity rapidly increases with the number of voltage levels. However, compared to the 3-level neutral point clamped topology, the individual valves are switched approximately half the number of times in the 5-level topology and the harmonic performance at the output terminals is better. The uneven utilisation of the valves and the escalating voltage ratings of tap-diodes may make the economical viability of a pulse number in excess of five questionable.

4.2.5 Three-Level Floating Capacitor Topology

The 3-level floating capacitor topology is an alternative to the 3-level neutral point clamped topology described in 4.2.3. In the floating capacitor topology, the additional voltage step is achieved by the inclusion of a separate dc capacitor in each phase. The circuit is controlled such that the dc voltage on the additional dc capacitor is 50% of the terminal-to-terminal dc voltage. The circuit diagram for a converter using 3-level floating capacitor phase units, along with the associated output voltage waveform, are shown in Figure 4.6.

The valves switch the ac buses between the different voltage levels by directing the current path through (or past) the dc capacitors, adding and subtracting the voltage of dc capacitors as desired. The intermediary dc capacitor may be by-passed for part of the power frequency cycle.

The total dc capacitor VA rating may be considerably larger for this topology than for the 2-level or 3-level neutral point clamped topologies. This is partly due to the need for separate capacitors for each phase, but also because the dc capacitors carry a significant ripple current.

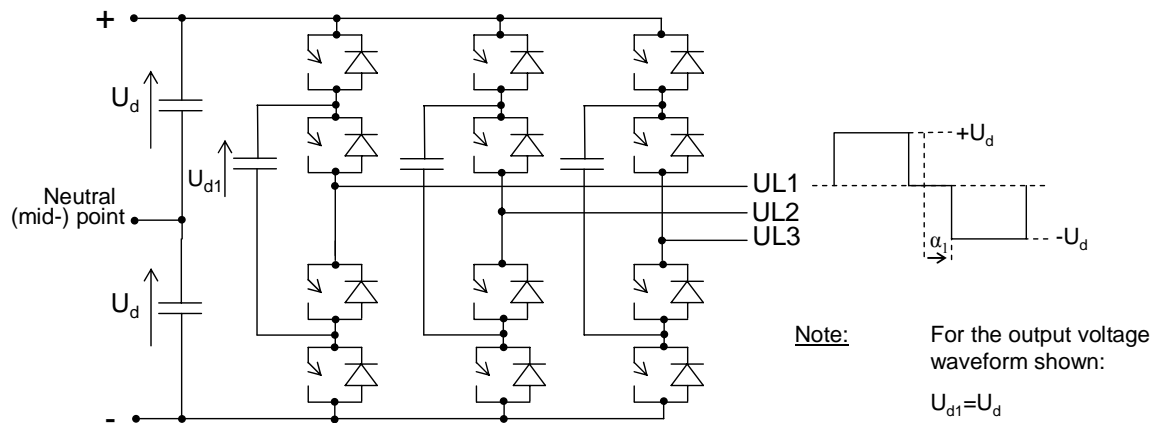

Figure 4.6: Diagram of a three-phase 3-level floating capacitor converter and the associated ac voltage waveform for one phase

The output waveform for a converter using PWM switching would be virtually identical to that of the neutral point clamped converter illustrated in Figure 4.4.

4.2.6 Multi-Level Floating Capacitor Topology

The floating capacitor converter circuit described in Section 4.2.5 can be extended to provide a circuit giving a higher number of levels than three. This is achieved by adding more dc capacitors and subdividing the VSC valves. As an example, Figure 4.7 shows the circuit diagram of a 5-level floating capacitor converter and the associated output waveform.

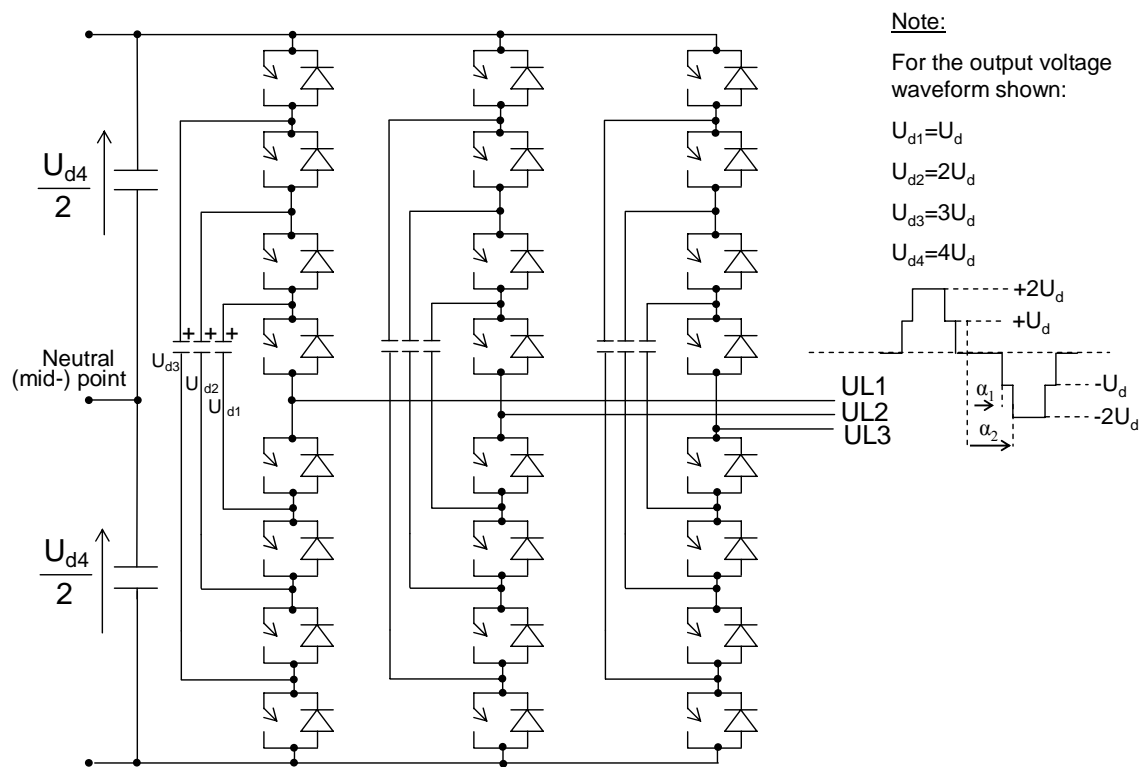

Figure 4.7: Three-phase 5-level floating capacitor converter and associated ac voltage for one phase

The valves switch the ac buses between the different voltage levels by directing the current path through the dc capacitors, adding and subtracting the voltage of dc capacitors as desired. The intermediary dc capacitors may also be by-passed for part of the power frequency cycle.

Typically, the total dc capacitor VA rating is considerably larger for this topology than for the 2- or 3-level neutral point clamped topologies. This is partly due to the need for separate capacitors for each phase, but also because the dc capacitors carry a significant ripple current.

In principle any number of floating dc capacitors can be used. However, when the number of voltage levels in the output waveform increases, and assuming constant apparent switching frequency for the converter, the volume of the dc capacitors also goes up, causing the capital cost and the footprint to get larger. Naturally, the complexity of the control and protection system also increases.

Compared to the 3-level topology (4.2.5), the individual valves are switched approximately half the number of times in the 5-level topology, and the harmonic performance at the output terminals is better.

4.3 COMBINATION OF CONVERTER PHASE UNITS

4.3.1 General

Each VSC substation may be constructed from a single converter unit of a phase unit topology, as described in Section 4.2. In this case the converter topology will simply be referred to by the same name as the converter phase unit topology.

In some applications it may be necessary or advantageous to combine several converter units, each constructed using the same converter phase unit topology. For example, it may not be optimal economically to achieve the power, voltage or current rating with a single converter unit. Similarly, several converter units may be combined to achieve good harmonic performance with very few switching operations per power frequency cycle, thus achieving reduced power losses.

The combination of two or more converter units can be accomplished in a number of ways. The dc terminals of the converter units can be connected in series or in parallel. Series connection may be an efficient way of achieving high voltage output, as the increase in internal converter clearances can be contained. At very high voltage the required clearance increases much more rapidly than linearly, as the voltage rises. This would result in the stray inductance in the commutating loop also increasing much faster, and the stresses on the VSC valve going up, resulting in either a disproportionate increase in the number of series-connected levels or higher power losses. Where the converter unit consists of a very large number of component converter units, both series and parallel connection of the dc terminals can be envisioned.

In principle, the ac terminals of the converter units could be connected in series as well as in parallel. This arrangement has been used for some STATCOM and other FACTS devices, and was also used in the VSC Transmission demonstration installation in Japan. However, series connection of the ac windings is unlikely to be adopted for ratings in excess of 100 kVdc. Therefore, this option will not be discussed further.

This section describes different methods that can be used to combine converter units. For all methods it is possible to use 2-level, 3-level or multi-level phase units. For simplicity, a 2-level converter has been used to illustrate the examples. It should be noted that PWM switching will normally be used for the converters. Selective harmonic elimination methods (SHEM) (see Chapter 9 for more detail) may also be used together with transformer phase shifting to eliminate certain harmonics. With fundamental frequency switching of a three-phase, 2-level converter, a six-pulse converter is achieved.

4.3.2 Combination Using Separate Transformer Windings

4.3.2.1 Series Connection of Converters

As with an LCC HVDC scheme, two six-pulse converters can be connected in series on the dc side and in parallel on the ac side. By phase shifting the transformer windings for the two converters by 30 degrees electrical relative to each other, this layout will operate as a 12-pulse scheme. This strategy may be called a 12-pulse converter arrangement. It can be used to extend the dc voltage capabilities of a VSC Transmission scheme relative to the capability of the individual converter unit. The harmonic performance of the converter unit can be improved relative to a basic 12-pulse converter by switching the valves more than twice per half power frequency cycle. One switching operation per half cycle is needed to control the amplitude of the ac voltage. Figure 4.8 shows an example of this arrangement.

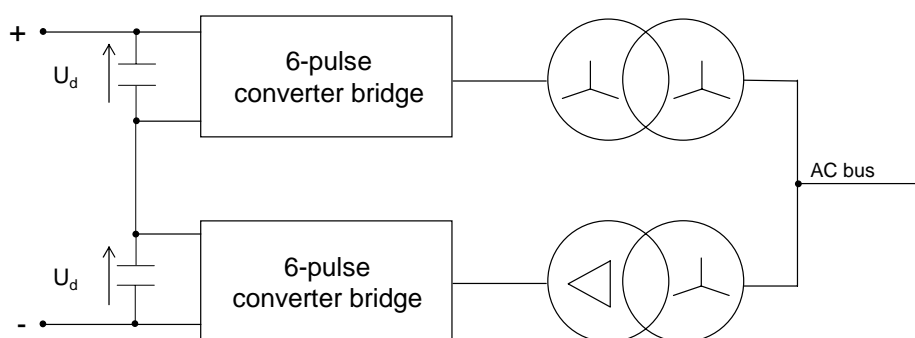

Figure 4.8: Two six-pulse units connected in series

In the arrangement shown in Figure 4.8, the transformer is similar to that in an LCC HVDC scheme. In particular, the two valve windings have to be capable of operating at an offset dc voltage. It should be noted that high levels of harmonic current might flow at those harmonics where cancellation is by transformer action. The circulating currents can be reduced by special modulation techniques, i.e., specially optimised pulse patterns. The transformer will need to be designed to withstand the relevant currents.

In principle, it is also possible to connect more than two converter units in series on the dc side, with each converter unit being connected to a separate transformer winding. An example of a system with four converter units in series on the dc side is shown in Figure 4.9.

If, under balanced conditions, the four transformer windings are phase shifted relative to each other by -7.5 , $+7.5$, -22.5 and $+22.5$ electrical degrees, a 24-pulse scheme is achieved. The comments above relating to switching strategy, power losses and transformer design also apply to this configuration.

The difficulties in designing a high-voltage and high-power transformer to meet all the technical requirements imposed on it (e.g., insulation requirements), and the need for balanced impedance between phases and windings, set practical limits on the number of windings in a single transformer.

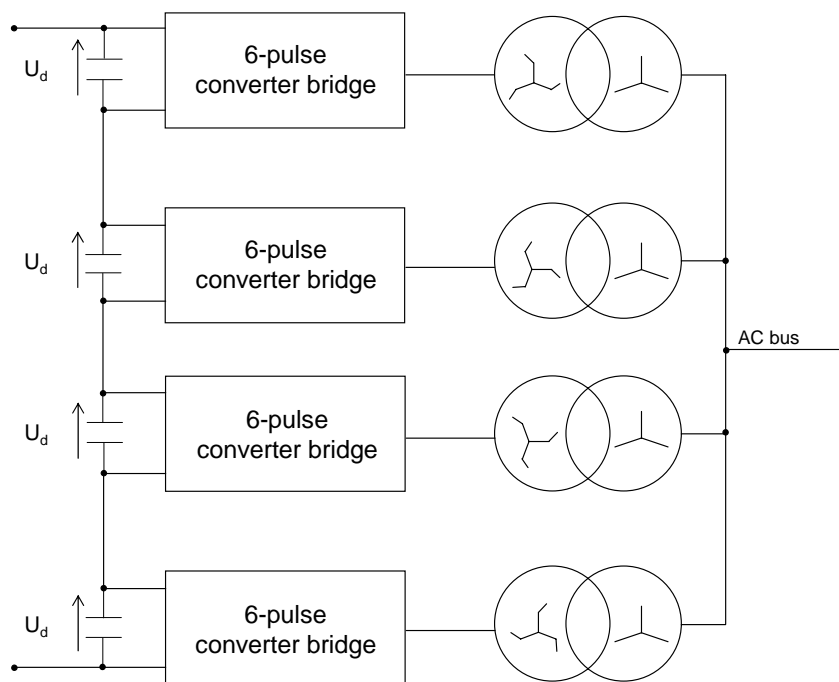

Figure 4.9: Four converter units connected in series on the dc side

4.3.2.2 Parallel Connection of Converters

When the current rating of the VSC Transmission scheme is increased beyond the capability of single devices, it may be advantageous to connect two or more converters in parallel.

To prevent undesirable interaction between the two parallel-connected converters, some level of impedance must be provided between the ac sides of the two converters. One method for achieving impedance between the converters is to use separate transformer windings for the parallel connection on the dc side, as shown in Figure 4.8. Such an arrangement is illustrated in Figure 4.10:

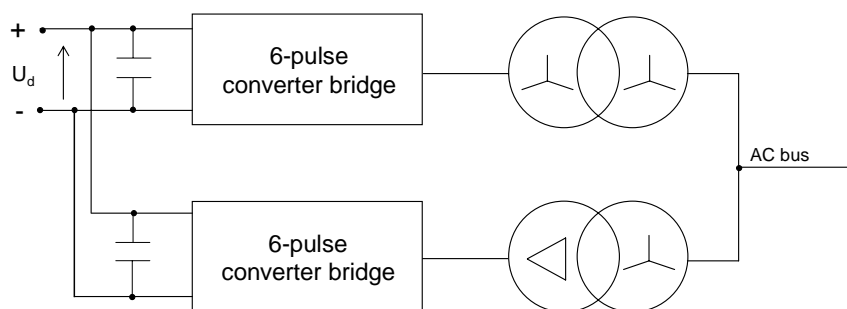

Figure 4.10: Converter isolation achieved by use of separate transformer windings

Individual transformers for each converter can be used to avoid the large circulating currents between the windings. These transformers should provide appropriate phase shift, and inter-phase transformers between the transformer primaries would provide the actual output.

4.3.2.3 Series and Parallel Connection on the DC Side

In principle it is possible to make an arrangement, as shown in Figure 4.11, where two converters are placed in parallel and then put in series with a set of two other converters.

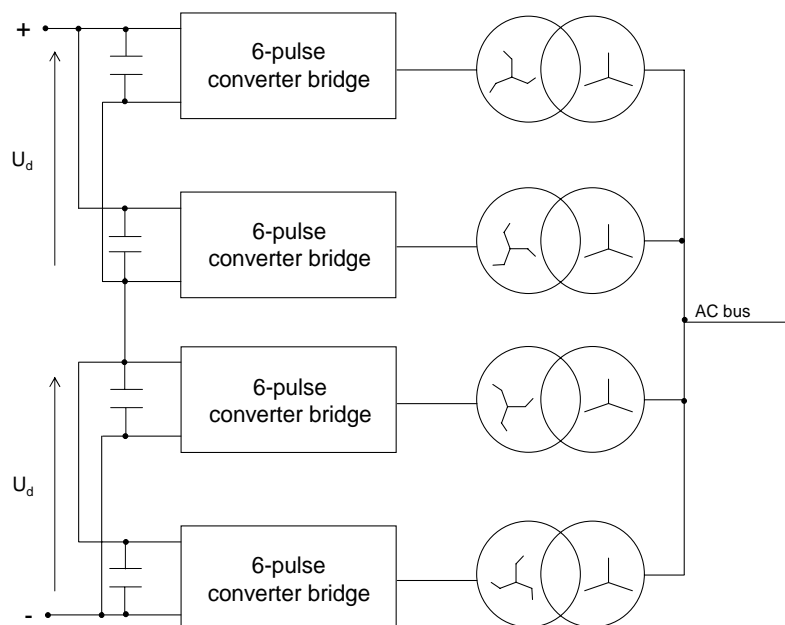

Figure 4.11: Two converters placed in parallel and then put in series with two other converters

The considerations outlined in Sections 4.3.2.1 and 4.3.2.2, above, also apply to this configuration. Practical limitations prevent this configuration from being extended to a significantly larger number of series- or parallel-connected converters. Because the technique is best suited to relatively low dc voltage, it is more applicable to back-to-back than to long distance VSC Transmission schemes.

4.4 CONCLUDING DISCUSSION

Many arrangements can be used in a VSC Transmission system. The configuration of the various converter terminals need not be identical.

4.4.1 Converter Phase Unit Topologies

The different phase unit topologies provide different advantages and carry different challenges. The following observations can be made in comparing the 2-level, 3-level and multi-level phase unit topologies:

The total harmonic voltage distortion at the ac terminals of a converter using sinusoidal PWM modulation is typically 60%, 30% and 15% for 2-, 3- and 5-level converters, respectively.

The 2-level converter will normally provide the lowest capital cost solution. It is also likely to be the most compact. However, when used at high dc voltage a large number of series-connected semiconductors are needed in the valves, and careful attention must be paid to the voltage distribution within the valve during turn-on and turn-off. Similarly, repetitive voltage excursions on the converter ac terminals between the voltage at the two dc terminals will result in high stresses on other equipment, which must be designed to withstand these stresses. To achieve good dynamic and harmonic

performance, the VSC valves are typically switched at a frequency of around 1-2 kHz. Consequently, switching losses for the 2-level converter tend to be relatively high.

The 3-level converter will normally cost more than the 2-level solution, since it requires additional hardware. The extra equipment means the footprint and volume occupied by the 3-level solution will likely be greater than that of the 2-level solution. The voltage excursion resulting from valve switching will only be half the voltage of a 2-level solution, and for the same apparent switching frequency, as seen by an external observer, each valve will only be switched half the number of times and at half the voltage. Consequently, the switching losses for a 3-level converter will tend to be about half that of a 2-level converter. It should be noted that the stray inductance in the commutation loop may be relatively larger per switched kV, because of the connections to additional capacitors, and this may increase the power losses in the valves. In addition, some of the advantages of this arrangement might be negated by more complex commutation processes, unequal valve loading (inner, outer or midpoint clamping valves), or more complex control and protection requirements.

Comparing the two different 3-level topologies described above, the additional switches will likely make the capital cost for the neutral point clamped converter slightly higher than for the floating capacitor converter. On the other hand, the 3-level neutral point clamped converter may be more compact, with a smaller footprint, since the floating capacitor circuit uses additional dc capacitors.

The multi-level converter will normally cost more than the 3-level solution, due to its additional hardware requirements. The footprint and volume occupied by the multi-level solution is also likely to be greater than that of the 3-level solution. However, the valve design will probably be easier, since the normal operating voltage for each valve in an n-level circuit is only $1/(n-1)$ of the terminal-to-terminal dc voltage. Similarly, the voltage excursion resulting from valve switching will only be $1/(n-1)$ of the voltage. For the same apparent switching frequency, as seen by an external observer, each valve is only switched $1/(n-1)$ times and at $1/(n-1)$ times the voltage. Consequently, the switching losses for a multi-level converter will tend to be lower than for a 3-level converter. However, some of these advantages might be offset by more complex commutation processes, unequal valve loading (inner, outer or midpoint clamping valves), or more complex control and protection requirements. Additionally, since each VSC valve will normally incorporate redundancy, the cost of providing redundancy increases as the number of levels increase.

In practice, the number of levels in a multi-level converter would be limited for several reasons. For example, it becomes undesirable to reduce the switching frequency for each valve beyond a certain value because of dynamic considerations and capacitor balancing, even though harmonic performance may not dictate a higher switching frequency. Similarly, the valve stresses will depend to a certain extent on the stray inductance in the commutating loop, and on a per semiconductor level this will tend to increase as the number of levels in the topology is increased. To avoid higher valve stresses due to stray inductance, it may be necessary to add or increase the value of snubber capacitance per semiconductor when using many levels in the multi-level topology. This would increase switching losses and reduce some of the benefit of the multi-level topology.

4.4.2 Combination of Converter Units

Converter phase units may be combined to form a converter terminal of greater rating. This may be done for one or more of the following reasons:

- The desired dc voltage cannot be achieved economically with available converter phase units
- The desired direct current cannot be achieved economically with available converter phase units
- To lower the switching frequency of the valves in each converter unit without affecting overall dynamic and harmonic performance

The use of complex winding arrangements may result in high costs for the transformers used in the combination of converter units. Similarly, power losses will be incurred in the transformers, reducing some of the benefits gained from less valve switching made possible by the use of a higher pulse

number in the overall output waveform. The manufacturer will have to consider these factors in optimising the overall scheme.

To some extent, the use of transformers to achieve higher pulse number and thereby allow each valve to be switched fewer times each power frequency cycle is similar to the objective of using multi-level topologies. One spin-off benefit of switching each valve less frequently is that it enables a wider choice of semiconductor devices to be used in the valve.

4.5. REFERENCES

- [4-1] Mohan, N., Undeland, T.M., and Robbins, W.P., *Power Electronics: Converters, Applications and Design*. John Wiley & Sons, Hoboken, NJ, 1995.
- [4-2] Andersen, B., Barker, C., "A New Era in HVDC?" *IEE Review*, pp. 33-39, March 2000.
- [4-3] Gyugyi, L., "Control of shunt compensation with reference to new design concept." *IEE Proceedings*, Vol. 128, Pt. C, No. 6, pp. 374-381, November 1981.
- [4-4] Newton, C., Sumner, M., "Multi-level converters: a real solution to medium/high-voltage drives?" *IEE Power Engineering Journal*, pp. 21-26, February 1998.
- [4-5] Meynard, T.A., Foch, H., "Multi-level Conversion: High Voltage Choppers and Voltage-Source Inverter." *Proceedings, IEEE PESC '92*, pp. 397-403, 1992.
- [4-6] Andersen, B.R., Xu, L., Horton, P., Cartwright, P., "Topology for VSC Transmission." *IEE Power Engineering Journal*, Vol. 16, No 3, pp.142-150, June 2002.

5. VSC TRANSMISSION VALVES

5.1 INTRODUCTION

The switching operations needed to achieve the conversion between ac and dc are performed by the valves. In a VSC Transmission scheme, the valves must be capable of turning on and off in response to control signals, irrespective of the state of the power circuit. Therefore, the valves used in a VSC Transmission scheme are fundamentally different from those in an LCC HVDC scheme.

Semiconductors are a crucial part of the VSC valve. The advances in semiconductor devices have been rapid and are the key to the future growth of VSC Transmission. Therefore, it is appropriate that this chapter begin with a discussion of semiconductors before moving on to discuss the complete valve.

5.2 SEMICONDUCTORS FOR VSC TRANSMISSION

An essential function of the semiconductor used in a voltage sourced converter is that it can be turned off and on by means of a control signal. Many different devices with this capability have emerged in recent years, and acronyms tend to be used for each of them. The devices and acronyms discussed in this chapter are as follows:

FWD	Free wheeling diode
GCT	Gate commutated turn-off thyristor
GTO	Gate turn-off thyristor
IEGT	Injection enhanced gate transistor
IGBT	Insulated gate bipolar transistor
IGCT	Integrated gate commutated thyristor
MOS	Metal oxide semiconductor

Acronyms are also associated with device characteristics. The acronyms used in this report are the following:

FIT	Failure in time
SCFM	Short circuit failure mode
SSOA	Switching safe operating area

5.2.1 Overview of High Power Semiconductors

The section presents a brief description of the various semiconductor components available for high power applications [5-1].

5.2.2 Thyristors

Traditionally, electronic conversion of electrical power in the high power region has been made using the principle of line commutated frequency conversion, using thyristors for control of the current flow. The thyristor is the equivalent of a “binary current valve” with two discrete states, either conducting or blocking the current. Turn-on is accomplished by injection of a gate current, while turn-off occurs naturally when the 50/60 Hz line current passes through zero. The thyristor cannot be turned off with the gate terminal, which significantly limits the range of applications for this device. Thyristors have been used to handle high power for more than 40 years, and are now available with impressive power handling capabilities (e.g., 12kV/1.5kA, 8.5kV/4kA,) and are used in LCC HVDC.

5.2.3 GTO and IGCT (GCT)

Based on the thyristor concept, gate-controlled turn-off was introduced in the late 1970s with the gate turn-off thyristor (GTO), making it possible to build converters for control of the output frequency. The GTO opened the way to high power voltage sourced converters, which were used, for example, in variable speed ac motor drives (with induction motor), STATCOM, and similar applications. However, the power losses for a GTO are higher than those for classical thyristors. The gate current required to turn off the device is also relatively high, and elaborate units are needed to supply these high gate currents. Usually, additional external circuits must be used to limit commutation overvoltages and di/dt to mitigate the stresses on the device. Snubber circuits are often used to control the voltage across the device.

A performance improvement in gate turn-off thyristors was achieved when a new device technology, the integrated gate commutated thyristor (IGCT) was introduced. This new technology achieves homogenous and well controlled injection and extraction of gate currents in thyristors by using an integrated gate drive unit. The homogenous switching across the device area significantly reduces power losses as compared to the GTO.

With its proven reliability, the IGCT represents an attractive alternative in many high power applications requiring turn-off devices, and is currently used in large motor drives, STATCOM systems, and traction power supply systems. The device itself is sometimes known as a GCT. A device rating of 6kV/6kA is available, making it the largest rating gate controlled turn-off device available at the end of 2004. However, the high energy required for the gate, combined with additional drawbacks mentioned below, make the IGCT less interesting for high-voltage applications requiring series-connected devices.

5.2.4 IGBT Type Devices

There have been numerous attempts to combine the microelectronic technologies used for very precise control of low-voltage signals in integrated circuits with the high power handling capabilities needed for power semiconductor devices. The most successful to date has been the insulated gate bipolar transistor (IGBT) concept, which combines a high-impedance, low-power gate input with the power handling capacity of normal bipolar transistors and thyristors.

The IGBT is a device based on the bipolar transistor concept controlled through an MOS. Bipolar transistors were commonly used before the IGBT was available on the market. An IGBT type device includes both the IEGT and the IGBT.

In the IGBT, control is accomplished by using a pattern of MOS transistors distributed on the surface of the device. The MOS transistors allow a high impedance control of the current flow through the device, requiring extremely small amounts of power supplied to the control gate. The ability to withstand high voltages and currents is provided by the vertical part of the device, comprising a bipolar transistor structure. This vertical transistor is of sufficient thickness to withstand high voltages. In addition, the vertical transistor effects are crucial to enhancing the conductivity of the semiconductor material, and hence, to reducing excess voltage drop over the device in the conducting stage.

The bipolar effect of the IGBT gives a self-limiting current through the device in case of short-circuit at the phase output. The device itself is protected by turning it off within a few microseconds. This feature is specific to IGBTs; by comparison GTOs do not provide any current limitation. As a consequence, IGBTs are capable of withstanding external fault conditions with self-protection and protection of the environment.

The second attractive feature of the IGBT is the linear control through the gate: di/dt as well as dv/dt can be controlled during commutations. Particularly, a di/dt-limiting reactor is not needed, as opposed to the GTO which always needs one. In addition, active voltage clamping by the gate is commonly used to assist the voltage sharing across series-connected elements.

The performance of IGBTs is related directly to the properties of the surface MOS transistor cells, and their success is largely due to the continuous development of these cell structures. The IGBT takes advantage of technologies that have been developed for microelectronic circuits in significantly larger markets.

The IGBT was invented in 1982. Although substantial progress in the area of IGBTs for lower voltages (600-1200 V) was made in the 1980s, it was not until the beginning of the 1990s that it was realized that this concept was also feasible for higher voltages (2.5 kV, then 3.3 kV in 1997, and 6.5 kV in 2002). Lately, a new type of IGBT has become available that takes advantage of the effect of electron injection from emitter to achieve a low saturation voltage similar to that of a GTO. This type of IGBT is called IEGT.

At the end of 2004 all VSC valves used IGBT semiconductor switches in forward direction with the capability to both turn on and turn off the current. To obtain the rated current capability, the IGBT is made of a number of chips connected in parallel in the same housing. There may be an anti-parallel free wheeling diode (FWD) integrated in the same semiconductor package to ensure current capability in the opposite (reverse) direction, and to prevent the application of reverse voltage. The FWD normally consists of a number of chips in parallel, in the same way as the IGBT. It is also possible to have the FWD in a separate package in parallel with the IGBT. The IGBT chip is designed only to have forward blocking capability, since in reverse direction there is always the anti-parallel diode for protection. The IGBT and the diode must have the same voltage capabilities.

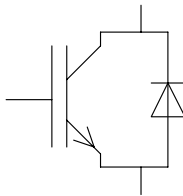

Figure 5.1: IGBT and antiparallel FWD

The IGBT, seen from a functional point of view, and its antiparallel FWD are normally referred to as an IGBT component.

5.2.5 Comparison of Devices

The IGBT is the most common choice for high-power and high-voltage VSC Transmission systems in use today because of its following characteristic features:

- It allows active voltage sharing control.
- Low-power control, since it is a MOS-controlled device. This is advantageous when operating at very high voltage levels.
- Transistor action, which enables precise control of the device in a manner that is not possible with latching alternatives. For instance, the converter can be turned off even in short circuit conditions.
- High switching speed, thus making high switching frequency feasible.

5.3 VSC VALVE DESIGN CONSIDERATIONS

In the sections below, only IGBTs are discussed.

5.3.1 Reliability (IGBT)

In addition to the number of series-connected IGBTs that are needed to sustain the converter voltage rating, each single valve in a VSC Transmission scheme must include a few redundant devices to enable continued operation in case of failure of an individual component [5-1]. Therefore, a faulty IGBT cannot be allowed to create an open circuit, since the valve must continue operating with the remaining healthy IGBTs. Instead, a faulty device must enter into a short-circuit mode and be capable of conducting current until it can be changed out, e.g., during a scheduled maintenance period. This capability of short-circuit failure mode (SCFM) operation is very critical for series-connected IGBTs, and must be verified by appropriate tests under conditions that are relevant for a particular application. Specially developed packaging is used for IGBTs for VSC Transmission and other high-voltage applications. These are press pack designs rather than the module design used for industrial, low-voltage applications. Standard IGBT modules do not have the required SCFM behaviour, as they normally use bond wires that open the circuit upon failure.

Each individual semiconductor device in a VSC Transmission scheme will be subjected to normal voltage for a substantial part of its operation time, that is, about half its rated voltage at 50% duty cycle. The probability that an incident cosmic particle will initiate a destructive current avalanche in blocking mode will therefore be substantially increased. This effect must be counteracted by proper design of the IGBT in order to keep the failure rate (FIT) below specified limits. This is a common issue for voltage sourced converters using GTO or IGBT for applications such as drives.

The LCC HVDC converters operate normally in relatively stable conditions, and the power flow changes at moderate rates. In contrast, the unique controllability of voltage sourced converters makes them attractive for applications that benefit from rather rapid changes in power flow (active or reactive power), e.g., for flicker mitigation. As an example, deregulation of the electrical power market has altered the exchange of power between separate networks. This, in turn, makes new and heavy demands upon the power cycling capability of semiconductor devices, which, again, must be verified by appropriate test methods.

5.3.2 IGBT Current Rating

One of the important design bases of the semiconductor in the VSC valve is rated current, which gives the nominal stress on the component and determines the power loss and junction temperature rise on the IGBT. In addition, to being able to handle peak current, including ripple and transients, the valve should also have margins for control and protection actions. The rated phase current gives the nominal stress on the component and shall be considered regarding power losses and junction temperature on the IGBT.

5.3.3 Transient Current Requirements

An important aspect of IGBTs is their capability to turn off current while voltage is applied. This capability is defined in the switching safe operating area (SSOA) shown in Figure 5.2.

During switching the IGBT must be able to turn-off the peak current, including ripple. Additionally, a margin is added to handle current control regulation and protection actions during transient conditions. The valve must also be capable of turning off the current should a short circuit occur close to the valve. The IGBT short circuit operation capability is defined by the SCSOA (short circuit safe operating area), which is slightly different from the SSOA under normal operation.

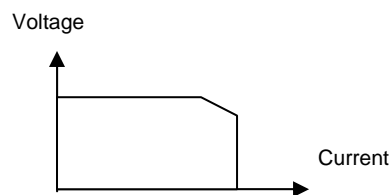

Figure 5.2: Typical SSOA for the IGBT

5.3.4 Diode Requirements

The FWDs in a VSC bridge act as an uncontrolled rectifier bridge. Thus they are exposed to special stresses, in particular during fault scenarios. Because the IGBTs can be switched off within microseconds during transients, their exposure to disturbances can be minimised. The diodes, however, cannot be switched off, so they have to be designed to withstand the special stresses.

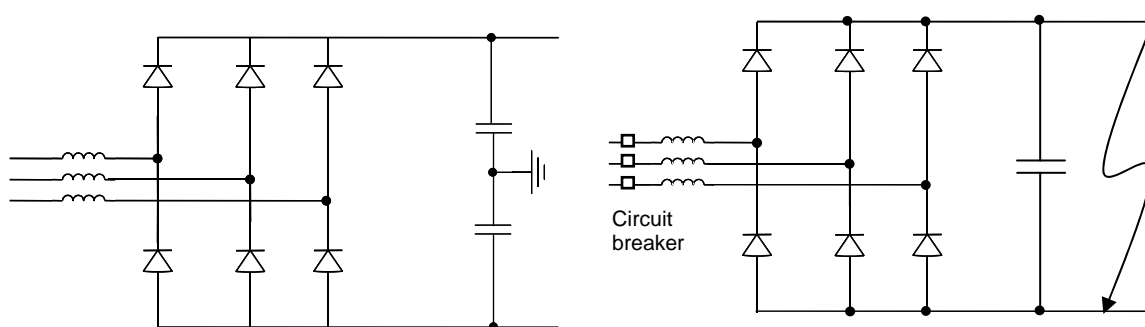

Figure 5.3: A 2-level VSC bridge with the IGBTs turned off

In case of a dc side fault, as shown in Figure 5.3, a short circuit between the two dc terminals creates a fault current path through the diodes. The currents in the ac phases in the VSC bridge are limited only by the short-circuit impedance of the ac network and the reactance in the converter, e.g., the phase reactors and/or transformers. The fault current is detected by the protection system, which will open the breaker on the ac side and thereby eliminate the fault current. A normal protection and breaker scheme takes a time equivalent of three 50/60 Hz fundamental frequency cycles before the fault current is extinguished. If the dc system only consists of cables, a fault will be very unlikely. However, the consequences may not be acceptable if the system is not designed to handle the fault. The valve should be designed to handle the fault current with an asymmetrical offset as a worst case. Here, no reapplied voltage occurs since the breaker has disconnected the ac system.

Another transient that the diode may experience occurs if the VSC is energized through the ac breaker when there is either no voltage, or a low voltage, on the dc side. In this case, the converter experiences a surge inrush current and an overvoltage will occur on the dc bus. The valve must be designed to handle the inrush current, or the current will have to be limited. The overvoltage must be damped or limited by external components. One method for doing this is to include pre-insertion resistors in the breaker. (See Chapter 6.) Another method is to charge the dc side with external charging devices prior to energising the converter. Here, a dc blocking voltage will appear after the current surge.

5.4 THERMAL DESIGN

In principle, the thermal and cooling system design for a VSC Transmission scheme is subject to the same requirements as an LCC HVDC, since in both cases the device junction temperature needs to be

controlled and low electrical conductivity of the cooling media is required because of the high voltages involved. However, the generation of the power losses is different.

5.4.1 Converter Power Losses

A main obstacle to using voltage sourced converters in bulk power transmission is the comparatively high power losses, including IGBT, filter and interface transformer losses. As indicated in Figure 5.4, the losses of the first generation of VSC-based HVDC converters were much higher than the goal value presented by the comparable LCC HVDC solution [5-1].

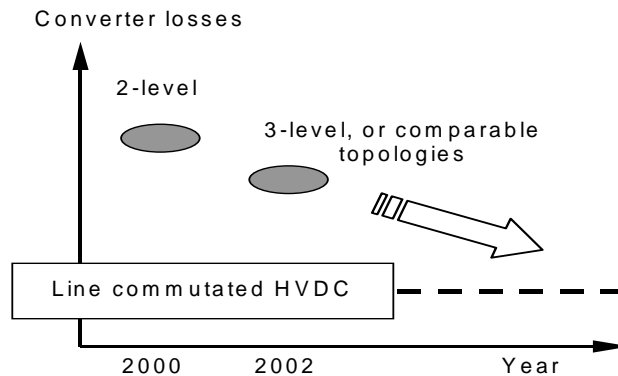

Figure 5.4: Voltage sourced converter losses in HVDC applications compared with those of line commutated converters

The 2-level VSC topology is attractive because of its simplicity. However, the switching frequency chosen must be comparatively high in order to keep the current ripple reasonably low, and this will result in high switching losses. One way of reducing the losses is to use more advanced converter topologies (see Chapter 4), but at the expense of simplicity. The on-going semiconductor device development and optimisation will contribute to a further reduction in overall losses in the future. Finally, a leap forward in loss improvement might be accomplished by employing new semiconductor materials, like silicon carbide (see Chapter 15).

A comparison of a 2-level and 3-level VSC converter with an LCC HDVC scheme will illustrate the power loss issue. With the semiconductor devices available at the end of 2004, a 2-level converter operating at a switching frequency of 1950 Hz has a power loss of approximately 3% for the complete VSC substation, including IGBT, filter, and interface transformer losses. Similarly a 3-level converter with a switching frequency of 1260 Hz has a power loss of approximately 1.8% for the complete VSC substation, including IGBT, filter, and interface transformer losses. The comparable loss figure for an LCC HVDC scheme is 0.8%, including, valves, filters and converter transformers.

5.4.2 Cooling System Design

The IGBT component, consisting of IGBT and FWD, has a thermal rating. Both the IGBT part and the diode part must not exceed their rated temperature at any continuous operating condition. This is verified and controlled by defining the coolant temperature, the device power losses, and thermal resistance of the component to the cooling media. A valve cooling system needs to be included which will have the same reliability and environmental requirements as LCC HVDC converters, but be able to handle higher losses.

5.4.3 IGBT Losses

The losses in the IGBT part consist of three main contributions: the on-state or conduction loss, the turn-on loss and the turn-off loss. The on-state loss depends on the average and rms current in the IGBT, as well as on the power factor, and is caused by the IGBT fixed forward voltage drop and the IGBT conduction resistance. The other two parts, turn-on and turn-off losses, depend on the current and voltage at each switching occasion, the switching frequency, and the characteristics of the device at turn-on and turn-off. The losses in the diode part are determined in a similar way. The diode has negligible turn-on losses, since it turns on as soon as a forward voltage appears. The turn-off loss due to diode recovery, however, is not negligible

There are also some losses in gate units and snubber circuits, if used, and leakage current losses during the off state. Due to the different power factor from an inverter to a rectifier operation, in most cases inverter operation is thermally decisive for the IGBT part, and rectifier operation is thermally decisive for the diode part. The reason is that the highest on-state loss for the IGBT appears in inverter operation and the highest on-state loss for the diode appears in rectifier operation.

High power dissipation at IGBT turn-on and turn-off is due to the fact that the device is subjected to high current and high voltage simultaneously during a substantial part of the switching process. In order to reduce the associated losses, the device should switch as fast as possible, that is, at as high voltage and current derivatives as possible.

In practice, however, the voltage derivative at turn-off is controlled to rather moderate values (a few kV/ μ s per device) to reduce the difficulties associated with the series-connection of IGBTs. Furthermore, the converter itself is comparatively bulky due to heavy insulation requirements, and this makes the stray inductance of the switching loop several times higher than in, for example, motor drive applications. Both of these factors contribute to comparatively high power dissipation at IGBT turn-off.

5.4.4 Voltage Rating

This section focuses on the design aspects to be considered when a large number of semiconductor devices are put together to create VSC valves for high voltages (>100 kV). Since many of the design aspects are the same as for LCC HVDC and FACTS devices, the description here will be limited to the special aspects of VSC converters.

Today's line commutated HVDC transmission utilizes thyristors with very high power handling capability and excellent reliability. Converter losses are low and converter equipment costs are minimized in this comparatively mature technology. Moreover, the converter must sustain different types of overload conditions emanating from various contingencies in the electrical network.

The IGBT will, in principle, experience the same tough requirements for electrical and mechanical performance and robustness as the thyristor. High power installations, however, pose demanding challenges for switching devices like IGBTs.

5.4.4.1 Aspects of Series Connection [5-1]

Because of the very high voltage rating of an HVDC converter, each single valve may comprise one hundred or more series-connected IGBTs. Proper voltage sharing is therefore crucial to ensure similar operating conditions for all devices. The use of snubber circuits reduces the difficulty associated with series connection, but they also add to the complexity of the VSC valve and may increase the power losses. It is possible to design the VSC valve such that it does not use traditional snubber circuits for protecting the individual IGBTs. In this case, the IGBTs must themselves maintain sufficient voltage sharing, both during switching and blocked conditions, by means of gate control. This, in turn, requires a minimum spread in device data concerning characteristic switching times, switching transient properties, and leakage currents in the blocked state.

Besides controlling the switching device in regular operation, the gate unit should keep the switching device within the safe operating area in all other operational and short-circuit conditions. IGBTs have proven comparatively easy to handle in this respect, thereby facilitating precise control of switching waveforms. This, in turn, is necessary for achieving proper control and protection strategies for the converter.

5.4.4.2 Commutation Process

The commutation process in a VSC converter occurs when one IGBT is switched off and the current is commutated to a diode, or when one IGBT switches on and current is commutated from the diode to the IGBT.

The turn-off process for an IGBT is illustrated in Figure 5.5. The switching does not take place instantly. During the switching there is simultaneous voltage across and current through the IGBT, which means instantaneous power versus time $p(t)=u(t)*I(t)$, giving the turn-off loss defined above as the integral of $(p*dt)$. To minimise the switching losses, it is therefore of great interest to make the switching as fast as possible, hence with as high di/dt as possible.

The drawback with high di/dt is that the inevitable stray inductance in the commutating circuit will produce a voltage ($u=L*di/dt$). This voltage will be in addition to the dc voltage across the IGBT and must be taken into account in the VSC valve design. It is highly desirable to keep the stray inductances in the commutation circuit as low as possible. This is a major consideration in the layout of the converter circuit.

The design of the VSC valve involves a total optimisation between losses, di/dt and voltage across the component for all VSC schemes.

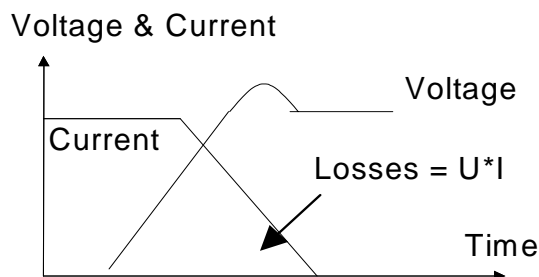

Figure 5.5: Voltage and current across an IGBT and diode during switching

When increasing the dc voltage to 100 kV or more, the same phenomenon occurs. However, at the higher voltage clearances increase very rapidly and it becomes more difficult to achieve a commutating circuit that has low stray inductance. On the other hand, there will be several series-connected IGBTs that will share the increased voltage due to the commutation. Provided that the increase in stray inductance is not too much higher than the increase in the number of IGBTs, the design principle will stay the same, i.e., stray inductance per IGBT should remain. If this is not possible, it may be necessary to improve the techniques or use snubber circuits to achieve the satisfactory series connection of devices.

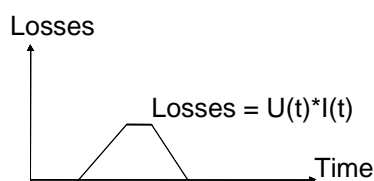

Figure 5.6: Losses in an IGBT and diode during switching

It is thought that there is no technical limitation to the dc-voltage that can be achieved for a VSC Transmission scheme. However, as the dc voltage increases, the power losses and capital costs may increase more than linearly.

5.5 MECHANICAL STRUCTURE OF THE VALVE [5-1]

Because of the high number of series-connected IGBTs, the converter valve must be divided into several stacks that each contain a manageable number of series-connected devices. Furthermore, the stacks must be very compact to ensure low stray inductance of the commutation loops.

Figure 5.7 shows a possible arrangement of a VSC valve. Each semiconductor component is clamped between heat sinks, and the entire IGBT level, including the gate control unit, may be surrounded by shields to equalize the electric field around the stack. This very compact design requires IGBTs of limited height that are well adapted for stack mounting. Their mechanical robustness must be sufficient to withstand the high mounting force needed to ensure a good thermal contact and the mechanical stability of the whole assembly. Furthermore, the IGBT housing should be designed to prevent fire or any other severe damage in the converter if the valve, by accident, should be subjected to a heavy short-circuit.

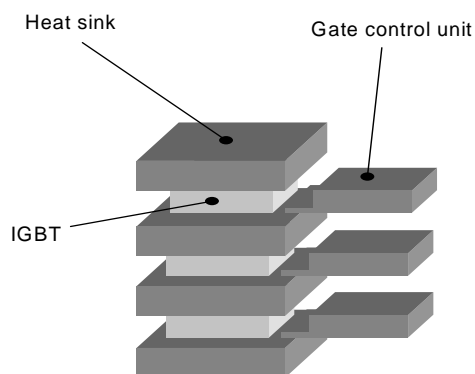

Fig. 5.7: Possible arrangement of an IGBT stack assembly

5.6 VALVE HALL OR VALVE ENCLOSURES

As with LCC HVDC thyristor valves, VSC valves must be installed in specially designed valve halls or separate valve enclosures. The requirements for these buildings are the same as for high-voltage LCC HVDC converters. However, the repetitive and fast switching of IGBTs with high voltages causes disturbances at higher frequency than for LCC HVDC schemes. Special attention must therefore be given to the EMC screening and grounding system surrounding the valve hall or valve enclosures.

As the VSC technology is more compact than an LCC HVDC scheme, it may be advantageous to install the entire VSC Transmission station indoors, to minimise the environmental impact.

5.7 REFERENCES

- [5-1] Chokhawala, R., Danielsson, B., Amgquist, L., "Power Semiconductors in Transmission and Distribution Applications." *Proceedings of the 2001 International Symposium on Power Semiconductor Devices & ICs (ISPSD)*, Osaka, Japan, pp. 3-10.
- [5-2] Blidberg, I., Kabza, H., Kawakami, N., Lafon, L., Larsen, E., Lips, P., Rashwan, M., Undeland, T.M., "Semiconductor power devices for use in HVDC and FACTS controllers." CIGRÉ Working Group 14-17, April 1997.

6. OTHER MAIN EQUIPMENT FOR VSC TRANSMISSION SCHEMES

6.1 INTRODUCTION

According to its principle of operation, only a few components are essential in a voltage sourced converter (VSC). These are:

- A means to convert dc into ac voltages provided by a converter comprising VSC valves and controls
- An ac side reactance provided by phase reactors, transformers, or a combination thereof
- A dc voltage source provided by at least one VSC dc capacitor

In addition to these key components, a complete VSC substation may also need:

- AC and dc filters
- Transformers
- Surge arresters
- Circuit breakers and switches
- Measuring equipment

The list of additional VSC substation components is identical to those used in an LCC HVDC system, which underscores the similarities between the two technologies. In particular:

- Converter operation generates unwanted harmonics that require harmonic filters.
- The ac system voltage rarely matches the optimal operating voltage of the VSC valves and must be adapted by transformers.
- Currents and voltages must be measured for control and protection purposes.

Similarities between both technologies also exist in terms of component stresses, such as:

- DC voltage stresses on insulating material
- Dielectric and thermal stresses due to harmonic voltages and currents
- Stresses due to saturation of transformer or iron core reactors (if any), as a result of dc current components caused by dc voltages due to non-ideal operation of the converter

However, there are also some special characteristics associated with VSC technology, which lead to different design principles as well as different stresses of the VSC substation components.

One difference results from the ability of a VSC to nearly eliminate harmonics in the lower frequency range. As a consequence, only filters with higher tuning frequencies may be required, and such filters are normally cheaper and more compact than those with lower tuning frequencies.

Another difference relates to the high frequency harmonics that result from the repetitive fast commutation processes and the associated rapid changes of high voltage (dv/dt) and current (di/dt). Two frequency ranges may be distinguished, middle and high.

Harmonics in the middle frequency range (from some kHz up to about 500 kHz):

- Cause additional losses due to skin effect and induction
- Excite characteristic frequencies of reactor coils (part of transformers and reactors)
- Stress insulation materials due to high frequency polarisation

- Have to be considered in regard to electromagnetic interference, telecommunication and power line carrier communication

Harmonics in the upper frequency range (above 500 kHz):

- Spread wavelike
- Appear partly as electromagnetic radiation
- Are transferred mainly by means of leakage capacitance via transformers and reactors

Harmonic generation varies according to the VSC topology chosen, the type of controllable switch in use, and the VSC switching technique. However, disregarding quantitative differences, the component design has to take into account similar criteria. This chapter describes typical component stresses caused by VSC operation and gives an overview of the important design criteria for the VSC substation's power components. The design concepts considered are those of practical importance at the end of 2004.

Different manufacturers may use different design philosophies and arrive at different optimised technical solutions for a project's specific requirements. An equipment specification should clearly state how the owner will evaluate specific features of the VSC Transmission scheme. Unless there are important reasons to preclude technical concepts, the room for optimisation should not be narrowed. (See also Appendix B)

6.2 POWER COMPONENTS OF A VSC TRANSMISSION SCHEME

Figure 6.1 shows the basic structure of a VSC substation and the location of the major power components. Depending on the design concept and the VSC substation topology, several components might occur more than once in a real structure, while others might not be needed. The functions and important design aspects of each component are briefly explained in the following paragraphs.

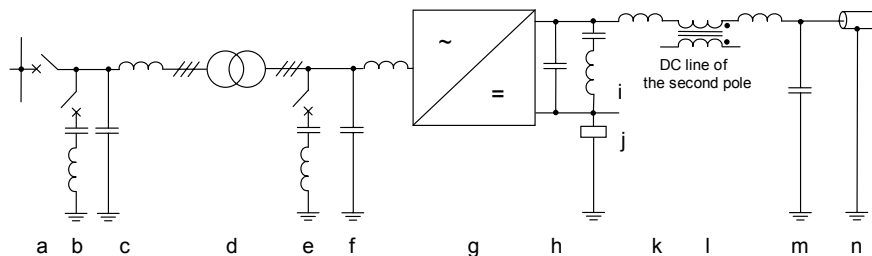

Figure 6.1: Major components that may be found in a VSC substation

- | | |
|--|--|
| a) VSC substation circuit breaker | h) VSC dc capacitor |
| b) System side harmonic filter | i) DC harmonic filter |
| c) AC side radio frequency interference filter | j) Neutral point grounding branch ¹⁾ |
| d) Interface transformer | k) DC reactor ²⁾ |
| e) Converter side harmonic filter | l) Common mode blocking reactor ²⁾ |
| f) HF-blocking filter/phase reactor | m) DC side radio frequency interference filter ²⁾ |
| g) VSC unit | n) DC cable or overhead transmission line ²⁾ |

¹⁾ The location of the neutral point grounding branch may be different depending on the design of the VSC unit.

²⁾ Not normally required for back-to-back systems.

6.3 VSC SUBSTATION CIRCUIT BREAKER

The VSC substation circuit breaker is located at the feeder from the ac transmission system to the VSC Transmission scheme. Its main function is to connect and disconnect the VSC substation to and from the ac system. There are no special requirements compared to what is common practice for normal circuit breaker applications as described in [6-1].

If large filter banks are switched by the VSC substation circuit breaker, the aspects of capacitive switching have to be considered, particularly steep inrush currents and high transient recovery voltages after opening the circuit breaker.

Depending on the start-up concept of the VSC Transmission scheme, a circuit breaker can be equipped with a closing resistor. The resistor reduces the charging currents of the dc circuit, resulting in smaller temporary ac system disturbances and fewer stresses on the free-wheeling diodes during energization. A closing resistor also reduces the inrush currents of the transformers and filters during VSC substation energization. The equivalent circuit of a circuit breaker, including a closing resistor, is shown in Figure 6.2.

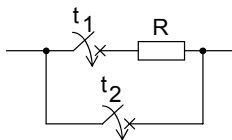

Figure 6.2: Equivalent circuit of a circuit breaker with closing resistor

Similar to circuit breakers that switch long overhead transmission lines, the closing resistor R is first connected at time t_1 by a separate switching contact on the breaker. After a delay that depends on the design philosophy, the resistor is bypassed by closing the main circuit breaker contacts at time t_2 . The switch in series with the resistor is opened again immediately after the main contacts are closed.

When the resistor is connected, the dc circuit will be charged from the ac system via the free-wheeling diodes in the VSC, which form an uncontrolled rectifier bridge. The charging of the dc circuit will complete when the circuit breaker main contacts bypass the resistor. The rate of the charging process reached depends on such system parameters as the short-circuit power, closing resistance, transformer impedance, transformer secondary voltage, and dc circuit capacitance. When the dc voltage is sufficiently high to charge up the gate power and generate a converter ac voltage that allows the start of operation under no-load conditions (i.e., with zero fundamental frequency current flowing into the ac system), the dc voltage can be controlled to its operation level.

The minimum energy absorption capability of the closing resistor is determined by the equivalent total capacitance of the dc circuit and the dc voltage to be reached. Moreover, fault scenarios can result in much higher energy duties and these have to be considered (e.g., closing the circuit breaker in case of a pre-existing short circuit in the VSC substation).

6.4 AC SYSTEM SIDE HARMONIC FILTERS

Depending on the design concept of a VSC substation, filtering may be required to prevent VSC-generated harmonics from penetrating into the ac system.

As a side effect, harmonic filters generate fundamental frequency reactive power. If the ac system is not capable of absorbing this reactive power, it can be compensated by appropriate control of the VSC, or the use of a shunt reactor.

If low order harmonics are suppressed using appropriate methods, like PWM, higher pulse numbers, or multi-level VSC topologies, filters can be tuned to higher frequencies. Filters with higher tuning frequencies are normally cheaper and more compact than filters for low order harmonics.

However, the system design, including the choice of filter branches, requires a global optimization, which is influenced by several considerations, including:

- Investment cost versus capitalised losses (see also Chapter 13)
- Investment cost versus reliability
- Technical performance aspects of the large filters, e.g., impact on ac system transients and system stability, including dynamic overvoltages due to reactive power surplus
- Space requirements

Because there is no need to switch filters to balance the reactive power demand of the VSC substation, circuit breakers for the filters can be omitted in many cases. However, it might be reasonable to equip filter branches with separate circuit breakers—for instance from a reliability/availability point of view.

The design principles of system side harmonic filters and any associated circuit breakers do not differ from the design practice for LCC HVDC or FACTS. High pass, single, double or triple tuned filters may be used [6-1], [6-2], [6-3].

6.5 RADIO FREQUENCY INTERFERENCE FILTERS

Radio frequency interference (RFI) filters reduce to acceptable limits the penetration of high frequency (HF) harmonics into the ac system.

HF harmonics generated require special attention during the design of a VSC substation. To calculate line-carried HF harmonics, a detailed representation of the VSC substation layout is necessary, including the structure and geometry of power components, busbars and grounding system. Additionally, the current and voltage waveforms experienced during the conversion process must be known.

The design principles for the RFI filter do not differ from the design practice for LCC HVDC or FACTS.

6.6 INTERFACE TRANSFORMERS AND PHASE REACTORS

In many cases, the VSC substation design will include interface transformers. In general, they can fulfill the following tasks:

1. Provide a reactance between the ac system and VSC unit
2. Adapt a standard ac system voltage to a value matching the VSC ac output voltage and allow optimal utilisation of VSC valve ratings
3. Increase the pulse number of the converter system, e.g., combining VSC units to form a 12-pulse system by a Yyd vector group
4. Connect several VSC units together on the ac side that have different dc voltage potentials
5. Prevent zero sequence currents from flowing between the ac system and VSC unit

Depending on the design concept applied to the VSC substation, the reactance mentioned under point 1 can be provided by a phase reactor, a transformer, or a combination thereof. The reactance is necessary to allow control of the ac output current of the VSC. Design criteria to determine the size of the reactance are:

- The required dynamic behaviour of the system
- The tolerable harmonic content of the converter ac current
- Constraints revealed from analysis of transient conditions and fault scenarios

If points 2 to 5 do not apply under specific circumstances, the required reactance could be provided by phase reactors, which would eliminate the need for a transformer.

For the design of reactors or transformers, the following points have to be taken into account:

- Stresses due to fundamental current
- Saturation characteristics with respect to possible ac harmonic and dc flux components
- Stresses due to harmonics in the lower and middle frequency range
- Dielectric stresses due to harmonics in the middle and upper frequency range
- Dielectric stresses due to normal operating voltage and transient voltages occurring during fault scenarios

Transformers and reactors can be designed to withstand the stresses caused by VSC operation. Particularly in the case of high-voltage VSC valves, the magnitudes of the harmonic voltages generated require detailed design studies to provide reliable information about the voltage and current profiles along windings. It is also necessary to fully understand the long-term withstand capability of the insulation materials. Depending on the design concept applied to the VSC substation, it could be advantageous to use a phase reactor as part of an HF blocking filter. As explained in Section 6.7, an HF blocking filter connected between the VSC unit and the interface transformer will mitigate HF stresses applied to the transformer. If the filter provides sufficient attenuation of HF harmonics, a standard transformer can be used.

The interface transformer does not require a tap changer. However, if a tap changer is used, it is possible to optimise the VSC operation, e.g., to achieve reduced power losses or to increase power capability under low-voltage conditions.

6.7 CONVERTER SIDE HARMONIC FILTERS AND HF BLOCKING FILTER

As mentioned above, it may be advantageous to mitigate the HF stresses of the interface transformer. At the same time it is desirable to leave the fundamental frequency component undisturbed to the largest extent possible. The mitigation function is best fulfilled by a filter with a low-pass characteristic, provided by a combination of a phase reactor L and a capacitor to ground C , as shown in Figure 6.3.

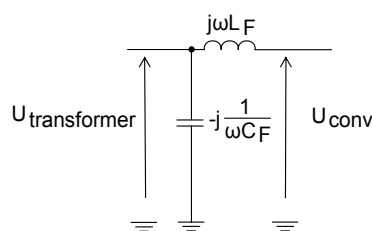

Figure 6.3: Typical structure of an HF blocking filter

A typical magnitude-frequency-characteristic of such a filter valid for frequencies up to about 100 kHz is shown in Figure 6.4. The characteristic frequency of the filter is determined by the series resonance of the reactor and the capacitor. For frequencies well below the characteristic frequency, the filter provides almost no attenuation, i.e., the amplification factor is close to unity. Well above the characteristic frequency, the filter provides increasing attenuation by -40 dB per decade. Around the characteristic frequency, the filter provides high magnification factors. At the resonance point, the magnification is limited by the damping included in the circuit.

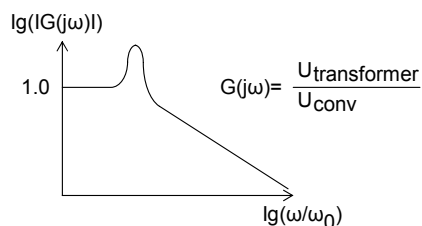

Figure 6.4: Typical magnitude-frequency-characteristic of an HF blocking filter

Choosing the characteristic frequency is an important issue for the design of a VSC substation. With HF blocking, the voltage components at frequencies above the characteristic frequency of the filter increasingly drop across the phase reactor. As a consequence, the reactor is exposed to high frequency stresses that require special attention during reactor design. Possible resonance phenomena along the reactor winding, as well as additional stresses on the insulation material due to high frequency polarisation processes, should be taken into account.

With increasing frequency, the impedance of the reactor increases and the VSC-generated harmonic voltages decrease. Thus, harmonic currents flowing through the HF blocking filter capacitor naturally become smaller with increasing frequency. However, depending on the tuning frequency of the filter and the harmonic generation of the converter, high frequency currents may contribute considerably to the losses occurring in the capacitor.

Depending on the design concept of a VSC substation, low order filters can be connected in parallel to the HF blocking filter capacitor. The filters can considerably reduce the gain factor of the transfer function $|G(j\omega)|$ at their tuning frequency.

6.8 VSC DC CAPACITOR

The VSC dc capacitor provides the dc voltage necessary to operate the VSC. It is connected directly in parallel to the dc terminals of the VSC phase units. For the design of the VSC dc capacitor, the following aspects need to be considered:

Commutation circuit inductance. Switching the semiconductor devices of the VSC causes HF commutation current to flow through the commutation circuit formed by the switching valves, the VSC dc capacitor, and the connecting busbars. Due to the stray inductance within the commutation circuit, these HF currents result in transient voltage stresses on the switching valves. To minimize these stresses, the inductance of the connection of the VSC dc capacitor to the valves should be as low as possible. (See also Chapter 5.)

DC voltage ripple. VSC operation results in harmonic currents flowing in the dc circuit. These harmonic currents cause harmonic voltages (also known as dc voltage ripple) determined by the dc circuit equivalent impedance as seen from the VSC dc terminals. The following factors will influence the size of the dc voltage ripple:

- Unbalances in the ac system and/or converter operation
- Pre-existing harmonics in the ac network
- VSC valve switching strategy
- Capacitance of the VSC dc capacitor

Choosing an appropriate value for the VSC dc storage capacitance is an important factor in determining the dc circuit equivalent impedance needed to keep the dc voltage ripple within tolerable limits. The design has to take into account aging effects of the capacitors, e.g. element failures.

Harmonic coupling of different VSC substations connected to one dc circuit. Harmonic currents generated by a VSC not only cause harmonic voltages on their own VSC dc capacitor, but also on the VSC dc capacitors in other VSC substations connected to the same dc circuit. As a result, the different VSC substations in a transmission scheme become mutually coupled via the dc circuit. To avoid unwanted interactions between the VSC substations, this coupling should be reduced to the largest extent possible. The capacitance of the VSC dc capacitor is an important factor influencing the coupling between the VSC substations.

Control aspects. The dc voltage influences active and reactive power exchange with the ac system. To achieve stable operation of the transmission system, it is important to keep the dc voltage within tight limits. Changing power orders, ac system unbalances, or system transients change the operating conditions of the VSC and can cause dc voltage fluctuations or oscillations.

Due to its energy storage capability, the VSC dc capacitor stabilises the operation of the VSC and allows the VSC closed loop control to adjust the control parameters according to the changing operating conditions. This interaction requires the dc storage capacitance to be coordinated with the response time of the closed loop control.

Important design parameters of the VSC dc capacitor are:

- Maximum dc voltage for continuous operation
- Maximum acceptable dc voltage variations under transient conditions, such as faults on the ac system
- Harmonic currents up to the HF range
- Minimisation of the stray inductance of the capacitor bank and its connections to the VSC valve

6.9 DC FILTER

DC filters can be an alternative to increasing the size of the VSC dc capacitor in cases where critical voltage or current distortion values occur within the dc circuit at a single or a small number of harmonics.

DC filters can be connected in parallel to the capacitor to reduce the equivalent impedance of the dc circuit at their tuning frequency in order to prevent harmonic currents from flowing into the dc line or cable. Single, double, or triple tuned filters can be used.

The design principles of the dc filters for VSC-based HVDC systems are similar to those for LCC HVDC systems [6-3], [6-4].

6.10 NEUTRAL POINT GROUNDING BRANCH

A grounding branch provides a connection from a specific point in the dc circuit to ground in order to define the potential of the dc circuit in respect to ground. Depending on the design concept, the dc circuit can be directly grounded or grounded through a circuit containing:

- Reactors
- Capacitors
- Resistors
- Arresters
- Electrodes for ground return operation

In the case of a bipolar transmission system, the grounding branch is usually connected to the midpoint of the VSC dc capacitors of a VSC substation. This point is referred to as the neutral point of the VSC substation.

In the case of a mono-polar transmission system, the grounding branch can be connected to either of the dc terminals of the VSC unit.

The design of the grounding branch is determined by the need to manage the stresses developed within the VSC substation under normal operation, as well as during several ground fault scenarios. It may differ according to the design philosophy applied to the VSC substation.

6.11 DC REACTOR

For long distance transmission, a dc reactor can be connected in series to a dc overhead transmission line or cable. It can serve the following purposes:

- Reduce harmonic currents flowing in the dc line or cable
- Detune critical resonances within the dc circuit

In a VSC Transmission system, a change in the real power to be transmitted requires a change in the dc current, while the dc voltage has to be kept within tight limits. Thus, the dynamic behaviour of the system largely depends on how fast the dc current can be changed. Since a dc reactor tends to prevent rapid changes of the dc current, its influence on the dynamic behaviour must be considered.

If a dc reactor is used in a VSC Transmission system, its size can normally be considerably smaller than one used in an LCC HVDC scheme. However, the design methodology is quite similar to that for LCC HVDC schemes.

6.12 COMMON MODE BLOCKING REACTOR

Harmonic currents flowing into a dc overhead line or cable of a bipolar long distance transmission scheme can be split up into differential mode component currents and common mode component currents. Differential mode component currents circulate between the plus and the minus pole of the system, while common mode currents return to the station through the ground path (differential mode component currents flow in the pole conductors into opposite direction, while common mode component currents flow in the pole conductors into the same direction).

Provided that the forward and return conductor of the transmission system are arranged in close proximity, the resulting electromagnetic field caused by the differential mode currents is very small. Thus, differential mode currents rarely cause electromagnetic interference with other power transmission or telecommunication systems.

Common mode currents, on the other hand, can form an extended ground loop and corresponding electromagnetic field. These may cause interference, especially with power or telecommunication lines running parallel to the dc transmission system.

One way to effectively reduce common mode currents is by using a common mode blocking reactor. A common mode blocking reactor consists of two magnetically-coupled windings having the same self impedance. Due to the winding arrangement, the reactor provides a small impedance for differential mode currents but a high impedance for common mode currents. The reactor, therefore, serves to block the common mode currents and leave the differential mode currents largely undisturbed and, in consequence, does not affect the dynamic behaviour of the transmission system.

The design of the reactor depends largely on the project. Important factors are:

- Transmission via overhead line or cable

- Electromagnetic interference issues
- VSC substation topology, especially grounding conditions
- The magnitude and frequency of the common mode component generated by the VSCs
- Geometry of main conductors and shielding of cables
- Location of telecommunication lines
- Environmental conditions, e.g., ground structure

Besides the performance requirements, the design has to also cover issues applicable to all VSC substation components, like transient stresses due to various faults, or insulation coordination.

There are other methods, as well, to reduce common mode current. These include:

- Additional dc filters that are effective for the ground mode component
- Improving the cable screen or parallel shielding wires
- Choosing high ohmic dc circuit grounding in the VSC substations
- Special control concepts, if the VSC substation topology allows the positive and negative pole voltages to be independently controlled

6.13 DC CABLE AND OVERHEAD TRANSMISSION LINES

To transmit electric energy over a distance, both cables and overhead transmission lines can be used. However, there are several aspects associated with the basic principle of VSC Transmission that may influence the choice:

1. Cables often have less impact on the environment than overhead transmission lines.
2. Since a VSC allows only one dc voltage polarity, the cable does not need to be designed for voltage polarity reversal. This allows new types of cables, such as extruded XLPE dc cables [6-5], to be used in long distance VSC Transmission systems.
3. Cables are much less prone to suffer faults than overhead transmission lines. Since overhead transmission lines are always exposed to lightning strikes and pollution, faults along them are likely. Most line outages are temporary, however, and transmission recommences once air insulation is restored. In the event of a cable fault, the outage would be permanent. Faults on overhead lines are normally easier to repair.

Unlike LCC HVDC, a VSC-based system has no inherent capability to clear dc line faults. A line-to-line or line-to-ground fault will cause the VSC dc capacitor to be discharged and fault current will be maintained via the VSC free-wheeling diodes until the VSC substation ac circuit breakers trip the scheme. In case of a temporary fault, power transmission can then be continued after a normal start-up of the scheme. This can be achieved in the order of 10 seconds.

An alternative would be to introduce special dc circuit breakers into the VSC substation dc line. If these switches can disconnect the line temporarily, the tripping of the scheme by the VSC substation ac circuit breakers can be avoided. However, there is no practical experience with such breakers for high-voltage applications.

The choice between the use of cables and overhead lines is influenced by environmental constraints as well as an overall optimization that considers total capital cost and transmission system reliability (see Chapter 13).

6.14 SPECIAL ASPECTS FOR BACK-TO-BACK DC TRANSMISSION SYSTEMS

If two or more ac systems are to be connected by a dc link, and the rectifier(s) and inverter(s) can be located on the same site, then a back-to-back dc transmission system can be formed.

A VSC substation of a back-to-back system can contain all the major power components already described for a general VSC-based dc transmission system. However, as the dc reactor, common mode blocking reactor and dc side RFI filter are used primarily to reduce harmonic currents flowing in the cable or overhead transmission line, they are normally not required in a back-to-back system.

6.15 References

- [6-1] International Electrotechnical Commission. *High Voltage Alternating Current Circuit Breakers*. IEC 56, Fourth Edition, 1987.
- [6-2] CIGRÉ Working Group 14.30, *Guide to the Specification and Design Evaluation of AC Filters for HVDC Systems*. CIGRÉ Report 139, 1999.
- [6-3] Kimbark, E.W., *Direct Current Transmission*, Volume I, pp. 343-389. John Wiley & Sons, Hoboken, NJ, 1971.
- [6-4] CIGRÉ Working Group 14.03, *DC Side Harmonics and Filtering in HVDC Transmission Systems*. CIGRÉ Report 92, 1995.
- [6-5] Karlstrand, J., Bergman, G., Jönsson, H-Å., “Cost-efficient XLPE cable system solutions.” *IEE 7th International Conference on AC-DC Power Transmission*, Conference Publication No. 485, pp. 33-38, November 2001.
- [6-6] Schettler, F., Huang, H., Christl, N., “HVDC Transmission Systems Using Voltage Sourced Converters—Design and Applications.” *Proceedings, IEEE PES Summer Meeting 2000*, Seattle, Washington, pp 715-720, July 2000.

7. VSC CONTROL

7.1 INTRODUCTION

Although there are many configurations for voltage sourced converters (VSCs), they all can be considered to exhibit a common operating concept. All configurations possess a series inductive interface separating the switching valves from the ac system. The switching valves generate a fundamental frequency ac voltage from a dc voltage. The magnitude and phase of the fundamental frequency component of this ac voltage at the valve side of the series inductive interface can be controlled. The control of this voltage magnitude and phase is the essential controlling function common to all VSCs.

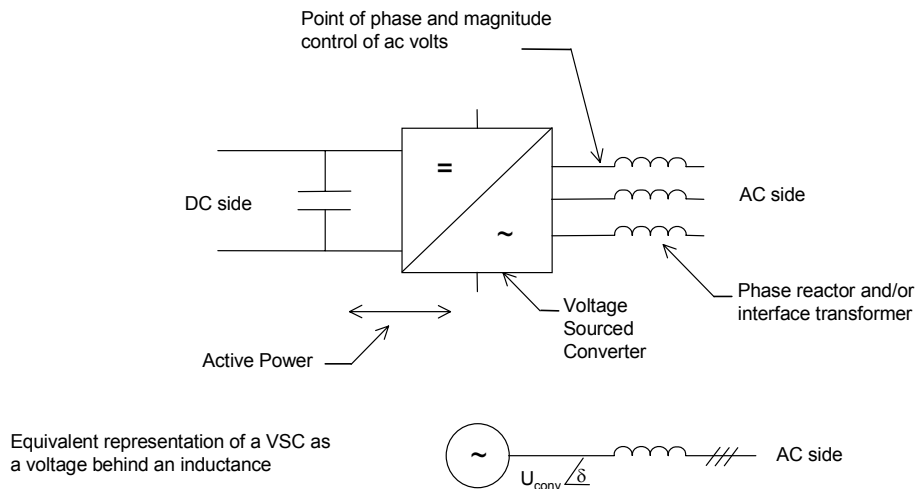

Figure 7.1: Representing a VSC unit as an ac voltage magnitude U and angle θ behind reactance

The control of the voltage magnitude V is achieved by generating a signal known as the “modulation index λ .”. The modulation index is a signal whose magnitude is within the range 0 to 1.0. If the voltage magnitude V is high (the modulation index near or at 1.0) and greater than the ac side voltage, then reactive power will be transferred into the ac side similarly to an overexcited synchronous machine. If the magnitude V is low and less than the ac side volts, the VSC will be absorbing reactive power similarly to an under-excited synchronous machine.

The control of the phase angle δ is achieved by shifting the phase of the fundamental frequency ac voltage with respect to the phase locked loop normally synchronized to the ac side voltage. Regulating the phase angle δ causes active power to be transferred through the VSC, because a phase angle in fundamental frequency voltage is developed across the interface reactor so that power flows into or out of the VSC.

A VSC therefore has the capability of acting as a rectifier or as an inverter, and/or as a generator or an absorber of reactive power. It is the control of the modulation index λ and the phase angle δ that dictates the strategies for controlling voltage sourced converters.

7.2 MODES OF CONTROL

The means of controlling the magnitude of the fundamental frequency ac voltage is dependent upon the configuration of the VSC. A multi-pulse VSC (24-pulse or 48-pulse) whose valves switch at fundamental frequency will generate an ac voltage that is directly proportional to the dc side capacitor

voltage. Therefore, ac side voltage control is achieved by controlling the dc side capacitor voltage. In turn, the dc side capacitor voltage is varied by pumping power from the ac side into it or out of it. If power is pumped into the capacitor, its charge will increase and consequently so will its voltage. If power is taken from the capacitor, its voltage will decrease.

Power can be taken from or fed into the ac side by varying the phase angle δ , as described above. In this way, dc voltage control is achieved by regulating ac phase angle δ . The dc side voltage can also be controlled from an external source, if need be. One disadvantage of using dc voltage regulation to control ac voltage is that it takes a finite time to charge the dc side capacitance.

The more usual and preferred case is to maintain the dc side volts constant. This is readily achieved with multi-level converters and/or, if pulse width modulation is used, with 2-level or multi-level converters.

For some applications, the benefit of voltage sourced converters is diminished if dc voltage regulation of the dc capacitor is applied to control ac voltage. In particular, VSC Transmission will not effectively operate in this mode of control. Instead, use of pulse width modulation or equivalent method with a fixed dc side voltage allows fast and relatively independent control of modulation index λ and phase angle δ , as described above.

Control of the modulation index λ and phase angle δ for VSC Transmission applications is usually achieved by means of either of two control strategies. These are:

1. Direct control
2. Vector control

Direct control means that the modulation index λ or the phase angle δ are directly adjusted by the parameters being controlled, as shown in Figure 7.2. Vector control is a current control strategy that permits the independent control of real and reactive power by the adjusting action of the modulation index λ from the phase angle δ , as shown in Figure 7.3. Its advantage is that the current control inherent in the strategy can limit overloading of the valves. Its disadvantage is that the current control loop is additional and may slow down the speed of response.

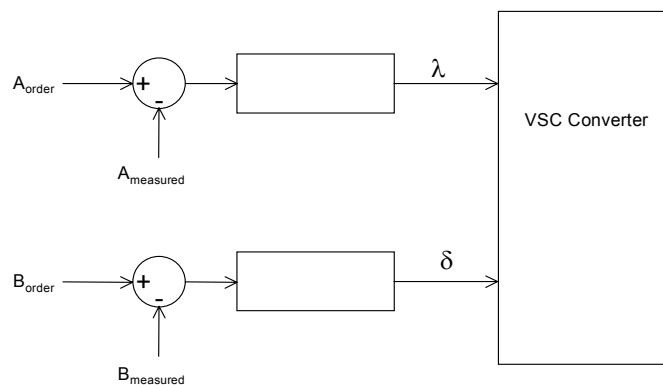

Figure 7.2: Direct control of Modulation Index λ and phase angle δ by parameters A and B

Figure 7.3 shows the control paths that are necessary for the decoupled operation of the two control loops. Without these, a change in the ordered real (or reactive) current also causes a transient change in the reactive (real) current. It should be noted that the method is sensitive to any measurement delays and may require additional compensation circuits.

With vector control, three-phase currents are transformed to d and q axis quantities based on the conventional abc to dq transformation, synchronized to the ac side three-phase voltage through a phase

locked loop (PLL). The d and q axis voltages generated by the vector controls are transformed to three-phase quantities and converted into line voltages by the VSC.

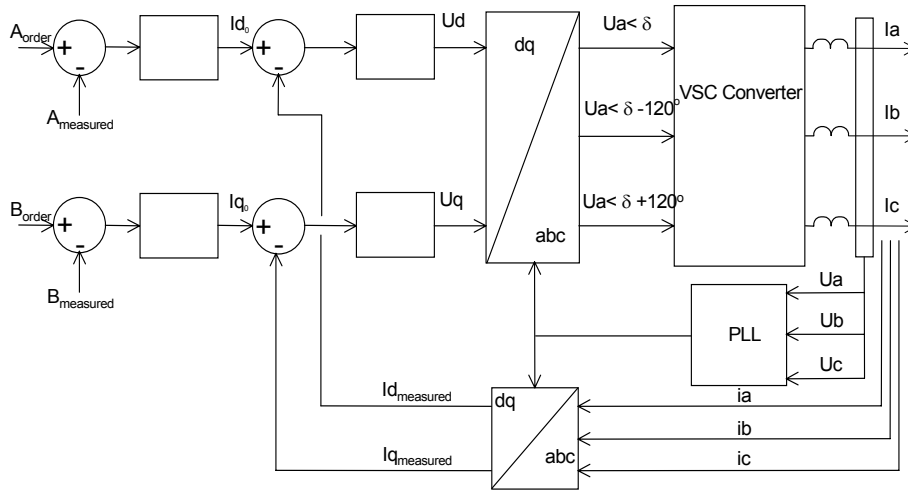

Figure 7.3: Concept of vector control to decouple parameters A and B by current control of the d and q axis currents. A three-phase voltage signal is generated that defines the magnitude and phase of the voltage generated by the VSC.

Another mode of current control is hysteresis control, which is normally not used in transmission but is frequently used for lower voltage applications, such as VSCs in distribution systems, active filters, flicker control and variable speed drives. Here, a desired current in each phase is created by the controller and compared with the measured phase current. If the measured phase current falls outside a band defined from the desired current, the valves of the VSC phase are switched to bring the measured phase current within the hysteresis band. While the error between the desired and measured current is within the hysteresis band, the valves of the VSC phase will hold their status [7-1].

The advantage of hysteresis control is that it makes very fast control of current possible. The disadvantage is that switching is erratic, so filtering more of a challenge.

With 2-level converters operating with PWM, and multi-level converters operating with voltage control, the degrees of freedom available are:

1. Frequency control by direct control of the main firing oscillator
2. The various control options provided by phase shifting the ac voltage that is generated by the VSC
3. The various control options provided by control of the magnitude of the ac voltage that is generated by the VSC

These degrees of freedom translate into the various control functions discussed below.

7.2.1 AC Voltage Control

AC voltage control is achieved by regulating the magnitude of the fundamental frequency component of the ac voltage generated at the VSC side of the interface reactor and/or transformer. With multi-level converters and 2-level converters operating with PWM, the magnitude of the ac voltage is directly achieved by variation of the modulation index λ . The dc capacitor voltage is usually held constant.

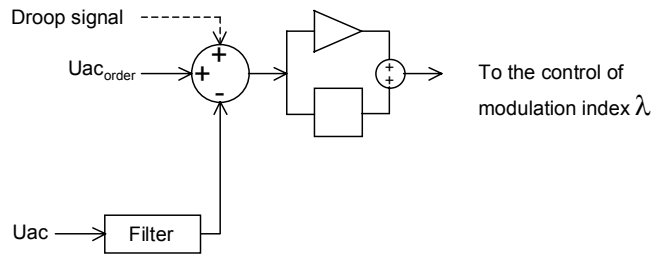

Figure 7.4: AC voltage controller

If the VSC is feeding into an isolated ac system with no other form of active power source of any significance, the ac voltage controller will automatically control power to the load. This assumes another converter, such as the sending end of a VSC Transmission link, independently controls the dc side voltage.

7.2.2 Power Control

To control power into or out of the ac system, the VSC must have a means for transferring power into or out of the dc side without over or under charging the capacitor. In a VSC Transmission scheme, this means that the converters at the two ends of the scheme must be controlled to work together. Generally, one of the two converters will have as part of its objective the control of the dc voltage (see 7.2.4 below).

Power control is achieved by regulating the phase angle δ of the fundamental frequency component of the ac voltage at the converter side of the interface reactance. Power is drawn from or pushed into the ac system depending on whether δ lags or leads the phase angle of ac bus voltages.

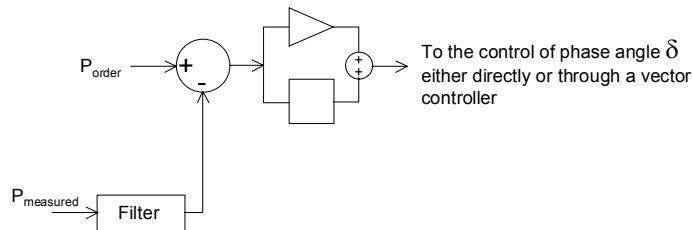

Figure 7.5: VSC power controller

Power is one parameter that can be controlled with fast response to improve the performance of the ac transmission system under transient conditions. This can be used to increase ac system damping of electromechanical oscillations, as well as to improve the transient stability of the power system following a fault.

7.2.3 Reactive Power Control

The need to use reactive power or reactive power control arises when other nearby controllers are acting to maintain ac voltage. To avoid interference between the various controllers, it is preferable to retain those VSCs not needed for ac voltage to provide reactive power control.

If all VSCs in close proximity to each other are controlling the same quantities, then it may be possible for each to participate in ac voltage control through a carefully designed droop characteristic. However, if the controlling functions of the VSC are quite different, such as separate and independent

power controllers, the droop characteristic may be difficult to define. Under these circumstances, a reactive power control may be preferable, with the settings either at zero Mvars or other fixed value slowly controlled by a joint var controller or by an order from the SCADA system.

7.2.4 DC Voltage Control

Common to VSCs is the dc voltage bus. A dc voltage controller on one or more VSCs connected and common to the dc voltage bus can regulate active power to maintain the required voltage level across the dc capacitor.

Figure 7.6 illustrates the dc voltage control scheme applied to the VSC designated for dc voltage control. The voltage across the capacitor U_d is measured and filtered and compared with the desired dc reference voltage U_{d_order} , and the dc voltage error is obtained. A proportional controller, and sometimes a proportional-integral controller, can maintain the dc voltage within prescribed limits.

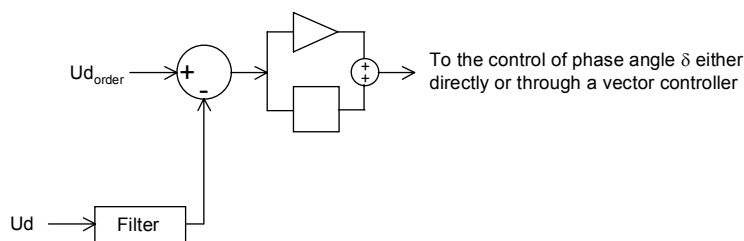

Figure 7.6: DC voltage controller

7.2.5 Current Control

Current control is an inherent feature of vector control, as can be observed in Figure 7.3. This is often a desirable requirement, so that ac current through the VSC is limited within an operating range to ensure the valves are not overloaded. Current can be controlled directly or, as shown in Figure 7.3, controlled in an intermediate stage for control of other parameters such as power, reactive power, or dc or ac voltage. Control of current is more effective if a high PWM frequency is applied.

7.2.6 Frequency Control

There are two ways a voltage sourced converter can control frequency.

1. By control of the frequency of the oscillator that determines the valve pulse firing sequence. This is essential when the power delivered to the ac system from the VSC is the dominant or perhaps the only source of power. Such is the case when a VSC Transmission system supplies power to an isolated load. If there is the possibility that the isolated load can be interconnected to the main ac system through separate ac transmission lines or cables, the VSC Transmission would need the feature in its controls where it switches from an independent oscillator to a phase locked oscillator synchronised to the newly defined external ac system voltage.
2. When the VSC feeds into or out of an active ac system where the frequency is influenced by ac generators and load frequency control, the VSC can participate in frequency control by regulating the power it delivers or takes from the ac system.

The ability of a VSC to control frequency and ac voltage, and absorb and deliver real power, makes it useful for assisting in black start conditions.

7.3 INFORMATION REQUIREMENTS FOR CONTROLS

The information needed to control the VSC converter includes the three-phase voltages or currents to which the VSC Transmission controls are synchronised, and the dc bus voltage and direct current. Three-phase voltage is usually used for synchronisation for those applications where the VSC interfaces into an active ac system.

Additional information required by the controls depends on the application. These signals would be selected from ac rms volts, dc volts, real power, reactive power and frequency, plus any particular signals needed for special functions, such as damping of electromechanical oscillations.

7.4 PERFORMANCE OF CONTROLS

The stable operation of VSC controls is essential for the satisfactory performance of the system and converter. The controls can be designed to allow the VSC Transmission to ride through temporary faults in the ac system. The controls must also be designed to work closely with the VSC Transmission protection system. To do so, adequate filtering of key signals is required. If the filtering is too excessive, the stable response of the VSC may be too slow. If signal filtering is inadequate, oscillations and instabilities may occur.

Care has to be taken in the grounding of VSCs and their components, such as the dc capacitor, filters and transformer windings. Ground mode dc side circulating current can occur and play havoc with the performance of the converter and the controls and increase the load current in the valves. Controls may not be able to limit these undesirable currents. This is particularly a problem with multi-level converters.

When the dc capacitor is divided into two series branches and grounded or connected in the middle, balancing controls are required to maintain an equal dc voltage across each half of the capacitor. Unbalanced dc side voltages will add non-characteristic even harmonics to the ac side. DC side voltage balancing is essential for 3-level converters, since the dc side capacitor is in two series sections with the mid-point grounded.

VSC Transmission must limit the dc voltage across and current through the gate turn-off solid-state valves. An ac system fault that depresses ac voltage on one or more phases may lead to dc overvoltage and overcurrent. The protective action applied, such as blocking, may disrupt the performance of the VSC Transmission, and the principal functions being controlled may in fact be out of control until the converters resume a regulating operation.

It is required that any protection action in VSC Transmission be resolved quickly (within 10 or 20 milliseconds). Care needs to be taken in designing and rating the controls and protection so that the converters are sized to meet the expectations of its owner and transmission operator. When the system is recovering from a disturbance, the controls must be fully functional, running free of limits, and not suffering from prolonged blocking of firing pulses.

7.5 LEVELS OF CONTROLS

The three levels of controls for a VSC are shown in Figure 7.7.

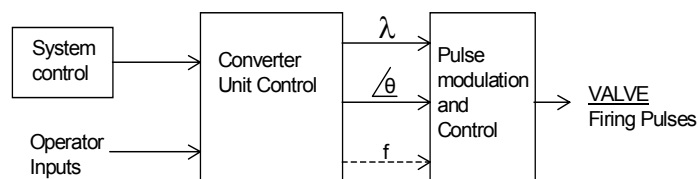

Figure 7.7: Levels of controls for a VSC

7.5.1 Firing Control

The organization and arrangement of firing controls depends on the configuration of the VSC. The actual firing controls are also dependent on the type of controllable switching device from which the valves are constructed.

If pulse width modulation is used, the valve firing sequence is regulated by the type of PWM applied. In order to obtain the harmonic cancellation possible for the least number of valve switchings each cycle, a selective harmonic elimination method (SHEM) may be used. There are several SHEM techniques from which to choose [7-4].

A key factor in the design of a VSC Transmission application is the compromise that must be reached between the degree of lower harmonic elimination through PWM or multi-pulse configurations and the number of ac filters required. There may be a requirement to conform to standards that define the allowable levels of harmonic distortion of the ac voltage [7-5]. To meet such standards, the converter configuration and valve firing control play essential roles in the design.

The firing control is very much dependent on the oscillator used. It can be either phase locked, if synchronised to an active ac system, or independently locked if feeding into an isolated system with no other form of frequency control.

7.5.2 Converter Unit Control

The converter control determines the dc voltage across the capacitor if the VSC is configured as a multi-pulse 2-level converter. This is done by adjusting the phase of the phase locked oscillator so that the phase angle difference created across the interface reactor causes the necessary power to flow into or out of the converter. The dc side capacitor is charged according to the level of dc voltage required.

If the converter is multi-level or operates with PWM, the converter control acts to change both the phase angle of the generated fundamental frequency component of the ac voltage at the converter side of the interface reactor, and the magnitude of that voltage.

Any frequency control desired of the VSC is also generated by the converter control and either adjusts the frequency of the oscillator in the firing controls, if feeding into an isolated ac system, or modulates power if feeding into an ac system with active generators.

The converter control system may perform the following functions:

- Protection of series converters
- Balance currents between parallel converters
- Generate and control the voltage phasor for the shunt component
- Generate and control the voltage phasor for the series component
- Perform negative phase sequence control and minimize unbalance effects that result in negative sequence currents
- Reduce dc current offsets in the ac side currents
- Control and limit dc side capacitor voltage
- Limit converter current
- Control the dc voltage balance for multi-level converters

7.5.3 System Control

System control enables the VSC located in an ac power system to perform the following system functions:

- Control of real and reactive power flows
- Control of voltage magnitude, angle and impedance within limits defined by the rating and capability of the controls
- Transient stability enhancement (if desired)
- Oscillation damping (if desired)
- Frequency control (if desired)

In order to achieve system control, the appropriate measured signals must be provided as inputs and feedback quantities.

7.6 COORDINATION OF CONTROLS

The degrees of freedom and flexibility offered by the VSC result in significant advantages for VSC Transmission compared to LCC HVDC or ac transmission. These advantages are realised by judiciously utilising the various control options described in Section 7.5 and coordinating them into the application required. Several example applications presented below demonstrate how the control features can be applied to advantage.

The basic control strategies can operate in all applications of VSC Transmission, including back-to-back VSC.

7.6.1 Supply to a Load with No Other Source of Generation

To supply an ac load that has no other source of generation, the rectifier connected to the main grid or generation may have the following controls.

- DC voltage control
- AC voltage control at the sending end system.

The receiving end may have controls as follows:

- Frequency control (defining the frequency of the load)
- AC voltage control of the receiving end system.

With these control modes in place, the load can be supplied with excellent ac voltage and frequency within ratings. As the load changes, the transmission self-regulates the power flow simply by maintaining ac voltage and frequency.

If an ac synchronous generator or an ac transmission line is added or switched on-line so that the VSC Transmission is relieved of providing the frequency control and all the ac voltage control to the load, the firing pulses may be switched from an independent clock to being phase locked onto the ac voltage. Alternatively, a droop characteristic for the frequency control and the ac voltage control may be invoked so that the VSC Transmission can operate in concert with the active system that the receiving end has changed to.

7.6.2 Interconnection of Two or More AC Power Systems

When a VSC Transmission scheme connects two or more ac systems, which can either be synchronous or asynchronous, there is some choice in what control modes may be applied. Each converter can control ac voltage, but if the ac system it feeds into or out of has a very high short circuit ratio, it may be preferable to control reactive power, possibly at zero. Considering the case where ac voltage is controlled at each converter, one of the rectifiers may include the following controls:

- DC voltage control
- Sending end ac voltage control

At other converters:

- Power control
- Receiving end ac voltage control

The dc voltage control and power control between converters are interchangeable. However, if electromechanical damping in the ac system is required, the power control should be located at the converters along with the damping control.

The basic rules for two or more converters connected in shunt, i.e., a multi-terminal scheme, are as follows:

- One converter controls dc voltage U_d (DC Voltage Control in 7.2.4)
- All converters except one control power P_d (Power Control in 7.2.2)

If the dc voltage control is taken as a fundamental control for example, a U_d - P_d characteristic can be achieved as shown in Figure 7.8 [7-6]. The U_d controller tries to keep the dc voltage to the reference value U_{d_order} by adjusting P_A (sending power at Terminal A) until P_A reaches the upper limit or the lower limit. When the P_A is equal to P_B (receiving power at Terminal B), the dc terminal voltage can be maintained as constant. If the dc voltage is lower, the U_d controller increases P_A until it reaches P_B . When P_B is larger than the upper limit, however, the dc voltage decreases. If U_d is higher than U_{d_order} , on the contrary, the U_d controller reduces P_A . When P_B is smaller than the lower limit, the dc voltage increases.

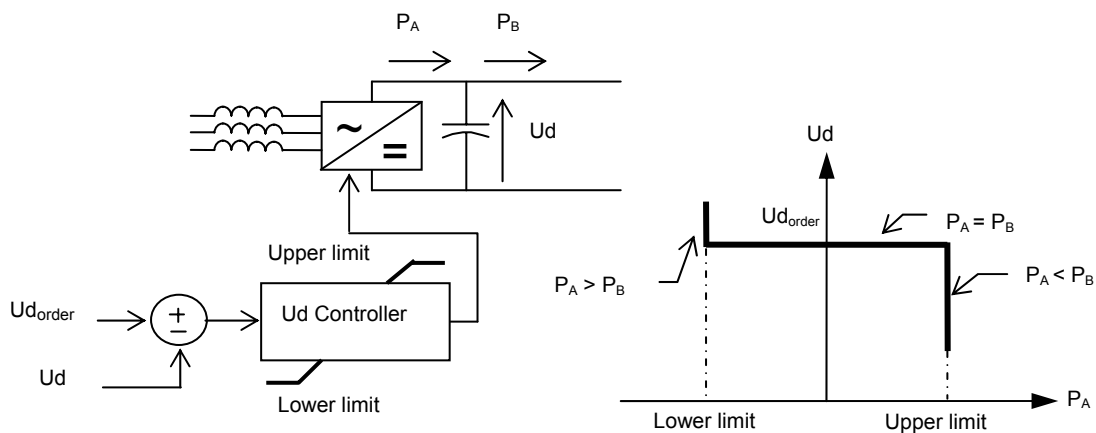

Figure 7.8: DC voltage control and the U_d - P_d characteristic

An example of coordination control for two-terminal VSC Transmission is shown in Figure 7.9. In this case, a converter at Terminal A controls dc voltage, U_d , and a converter at Terminal B controls power, P_d . In order to avoid unfavorable interference between dc voltage controllers at the two terminals, a voltage margin is introduced. At Terminal B, U_{d_order} is subtracted by the voltage margin, and the power controller with P_{d_order} controls the lower limit of dc voltage controller. The U_d - P_d characteristics for both terminals are shown in Figure 7.10. Terminal A controls the dc voltage, and Terminal B controls the power. Changing P_{d_order} at the master controller can control the power.

This is very similar to the coordination control of conventional LCC HVDC. Because LCC is a current sourced converter, the dc current control is selected as a fundamental control in general, and the current margin is applied to coordinate the controllers at the two terminals. For multi-terminal VSC Transmission, a similar idea can be applied [7-6].

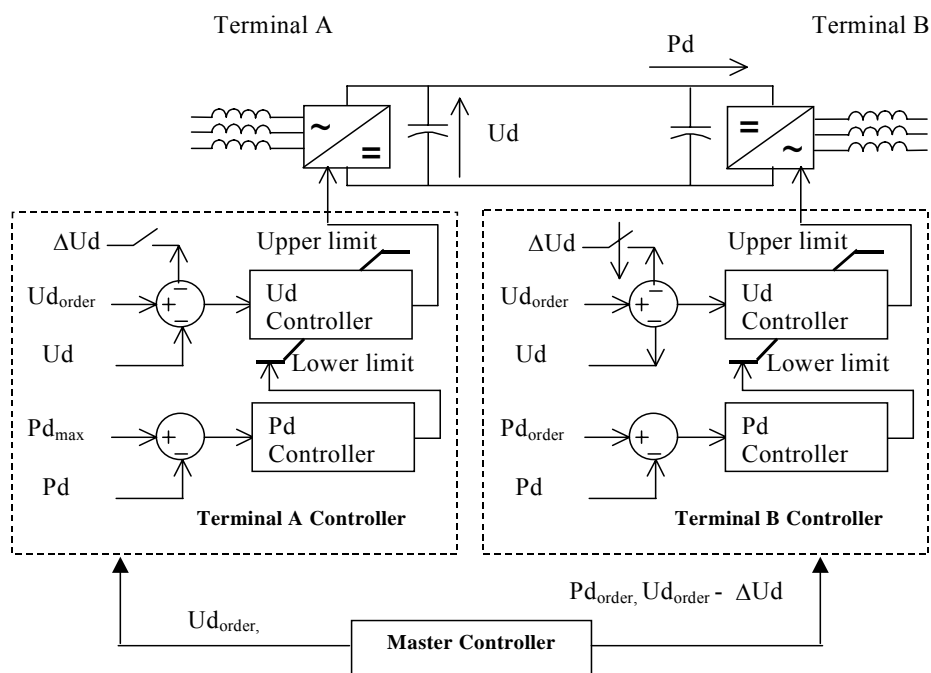

Figure 7.9: Coordination control example for two-terminal VSC Transmission

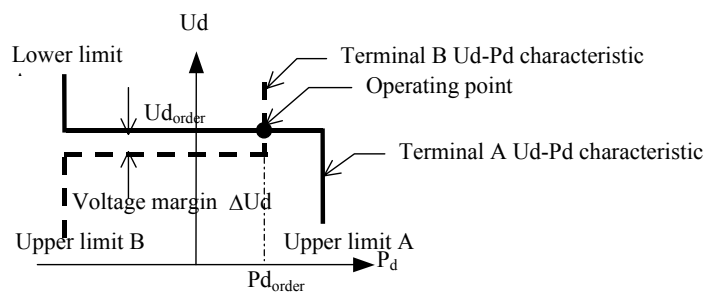

Figure 7.10: Operating point in voltage margin method

7.6.3 Telecommunication Between Converter Stations

For VSC Transmission control, there is no need for fast telecommunication signals between the ends. However, fast telecommunications between the converters may be applied for conditions such as:

- When fast power control is required between converters for a multi-terminal configuration, such as for coordinated damping of electromechanical oscillations
- When damping of electromechanical oscillations is required at the converter that is not controlling power
- If it is desired to reconfigure the control modes between converters

7.6.4 Supply from a Wind Farm

When dc transmission is required to bring power from a wind farm to a substation, VSC Transmission can be integrated into the wind turbine design for maximum performance and economy. This technology may be particularly applicable for offshore wind farms. At the sending end, ac voltage control, power control and frequency control can be coordinated with the generators, which can be induction machines. Best overall performance is achieved when the controls of the VSC sending end converter are coordinated with the turbine pitch controller (if used), the generator type, and the wind velocity. The sending controls for a wind farm may consist of:

- AC voltage control
- Frequency control
- Power control

The receiving end converter may incorporate the following modes of control:

- AC voltage control
- DC voltage control

7.7 REFERENCES

- [7-1] CIGRÉ Task Force 38.01.10, “Modelling New Forms of Generation and Storage.” CIGRÉ Brochure 185, April 2001.
- [7-2] Hingorani, N.G., Gyugyi, L., *Understanding FACTS: Concepts and Technology of Flexible AC Transmission Systems*. IEEE Press, Palo Alto, CA, 2000.
- [7-3] CIGRÉ Task Force 14.27, “Unified Power Flow Controller (UPFC).” CIGRÉ Brochure 160, August 2000.
- [7-4] Boost, M.A., Ziogas, P.D., “State of the Art Carrier PWM Techniques: A Critical Evaluation.” *IEEE Transaction on Industry Applications*, Vol. 24, No. 2, pp. 271-280, March/April 1988.
- [7-5] IEEE Standard 519-1992, Revision of IEEE Standard 519-1981, *IEEE Recommended Practices and Requirements for Harmonic Control in Electrical Power Systems*.
- [7-6] Nakajima, T., Irokawa, S., “A control system for HVDC transmission by voltage sourced converters.” *Proceedings, IEEE Power Engineering Society Summer Meeting 1999*, Vol. 2, pp. 1113-1119, 1999.
- [7-7] Xu, L., Andersen, B.R., Cartwright, P. “Control of VSC Transmission System under Unbalanced Network Conditions.” *Proceedings, IEEE PES Transmission and Distribution Conference and Exposition*, September, 2003.
- [7-8] Lindberg, A., “PWM and Control of Two and Three-level High Power Voltage Source Converters.” ISSN-1100.1616. TRITA-EHE 9501, Royal Institute of Technology, Stockholm, Sweden. 1995.
- [7-9] Lu, W., Ooi, B.T., “DC Over-Voltage Control During Loss of Converter in Multi-Terminal Voltage-Source Converter Based HVDC (M-VSC-HVDC).” Accepted by *IEEE Transactions on Power Delivery*.

8. FAULT PERFORMANCE AND PROTECTION REQUIREMENTS

8.1 PROTECTION SYSTEM PHILOSOPHY

For most components in the VSC Transmission system, the protection requirements are similar to those of an LCC HVDC scheme. The purpose of the VSC substation protection is to protect the facility from any damage caused by an external fault or an external overvoltage, to limit the damage in case of an internal fault within the VSC substation or, in some cases, to feed the fault (e.g., to permit the operation of fault detection relays in an isolated system).

In case of external temporary faults in the ac grid, the VSC Transmission may have to stop power transmission until the fault has been cleared. Once a temporary external fault has been cleared, the VSC should be able to restart and recover its transmission automatically or manually, depending on the requirement. However, the VSC can be designed so that a non-permanent fault should not cause it to trip.

When VSC Transmission supplies power to an isolated network, the protection philosophy has to be reviewed. The main change is that the short circuit current is so close to the nominal current that classical protection relays (overcurrent detection) might be prevented from operating correctly. In such cases the VSC scheme may be designed to feed ac faults in order to make classical protection relays operate.

In case of external faults in the dc line, the performance of the VSC Transmission will depend on whether a cable or an overhead line is used. For a cable, the fault is likely to be permanent and the VSC substation should be shut down. With an overhead line, the fault is likely to be temporary. However, to clear the fault it would be necessary to trip the ac circuit breakers at all terminals or the dc breakers (if any), as direct current would otherwise continue to be fed into the fault by the free-wheeling diodes in the connected terminals. After all terminals have been disconnected, a short period should be allowed for air insulation to be restored before the transmission is restarted.

In case of internal faults, the VSC substation protection has to isolate any faulty element and promptly shut down the VSC Transmission system. Internal faults can be a short circuit or abnormal operation that could cause damage to equipment or interfere with the effective operation of the ac system. The VSC substation should not be returned to service before an investigation of the fault has been completed.

The protection system may perform a number of different actions to achieve fault clearing:

- Blocking of the VSC valves
- Trip of ac circuit breakers
- Operation of protective dc clamping circuits, if any
- Trip and lockout of the ac circuit breaker and consequent isolation of the ac lines from the converters

The protection system should be reliable and selective. The protection functions should be provided with backup protection, in case a primary protection should fail.

How the required protection performance is obtained depends on the VSC design and control philosophy. Typically, two sets of protection circuits are included, each of them fed by separate measurement units/cores. The protection functions may be implemented in the control system or by protective relays, or by a combination of the two.

If both protective systems are “active,” a trip order may be generated from either of the two systems. This may, however, lead to unnecessary trips in case of measurements faults. Therefore, in instances where a redundant control system is provided, the standby controller can be activated and the trip executed only if the trip order remains.

The protection system may also be required to detect faults within the protection system itself, and must be able to discriminate between internal and external faults, so that the appropriate action is taken.

If the primary protection fails to operate, the backup protection must ensure that overcurrent, overvoltages or other abnormal stresses do not damage the converter components.

8.2 TYPE OF PROTECTION AND FAULT CLEARING ACTIONS

For most components in the VSC Transmission system, the protection requirements are similar to those of an LCC HVDC scheme. The essential exception is that a VSC is equipped with free-wheeling diodes. These diodes prevent reverse overvoltage stresses from getting to the valves, and may require overcurrent protection (inrush current and short circuit feeding without control) and dc voltage clamping devices. DC clamping devices, if required, will entail extra investment.

When a protection operates, the following fault clearing actions are taken, depending on the type of fault:

- Blocking of the converter, temporarily or permanently
- The ac breakers can be tripped, and for some protections locked out
- The ac filter breakers (if any) can be opened, and for some protections locked out
- Isolation of the converter from the dc line
- Rapid discharge of the VSC dc capacitor and cable (by discharge unit or dc chopper), if required

Temporary Blocking. For temporary external faults, the protection might command temporary blocking to protect the converter IGBT and free-wheeling diodes from overcurrents. After a few milliseconds, the valves are deblocked and an attempt made to restart. If the automatic deblocking attempt fails one or more times, permanent blocking should be carried out.

Permanent Blocking. At internal faults and permanent external faults, permanent turn-off control pulses will be sent to the IGBTs to achieve blocking. At the same time the ac circuit breakers will be tripped. The valves will stop switching and no current will flow through the IGBTs. After permanent blocking, the valves have to be deblocked manually.

AC Circuit Breaker Trip. An ac circuit breaker trip disconnects the ac side of the interface transformers from the ac power source. This prevents the ac power source from feeding a fault on the valve side of the interface transformer and on the dc side via the free-wheeling diodes. Also, the removal of ac voltages from the valves avoids unnecessary voltage stresses, especially when the valves have suffered severe current stresses.

Start of the AC Breaker Failure Protection. At the same time as a trip order is sent to the ac breaker, an order is also sent to start the breaker failure protection. If the breaker does not succeed in opening, the breaker failure protection orders a trip of the next breaker further out.

Set Lockout Relay for the AC Circuit Breaker. If a protection trip order has been sent to the ac breaker, a simultaneous order is sent to the lockout relay to prevent the breaker from closing before the operator has checked the cause of the trip.

Pole Isolation. The isolated pole sequence implies discharging of the dc circuit and the subsequent disconnection of the VSC from the dc line. This is either done manually during normal shutdown or during faults which require the disconnection of the dc line.

8.3 VSC SUBSTATION PROTECTION

VSC substation protection will differ depending on the VSC design and protection philosophy. Therefore, the protection system described here is only representative.

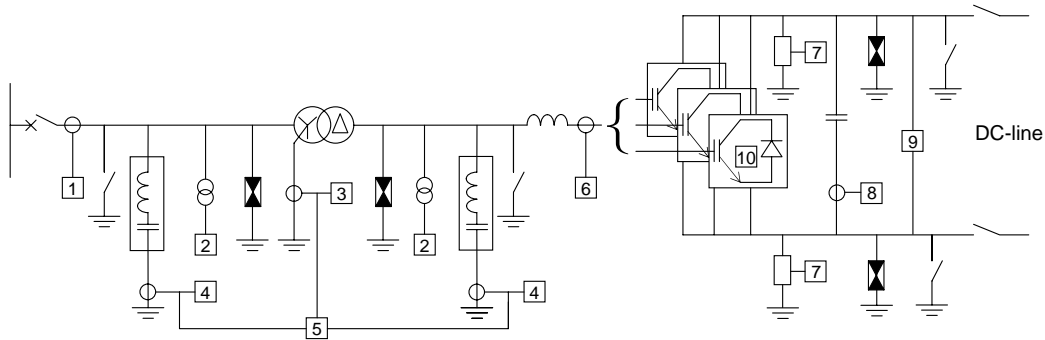

Figure 8.1: Protection concept of a VSC substation

- 1) Overcurrent protection of ac circuit breakers.
- 2) Abnormal ac voltage protection.
- 3) Earth fault protection.
- 4) AC filter protections.
- 5) Differential protection.
- 6) Overcurrent protection of the converter.
- 7) Abnormal dc voltage protection.
- 8) Overcurrent protection of the VSC dc capacitors.
- 9) DC discharge unit.
- 10) Valve protection, e.g., in the valve gate electronics.

Depending on the VSC substation design and the application, the following protections are usually applicable:

- AC voltage phase unbalance protection
- DC line/cable earth fault protection/supervision
- Transformer protection
- Loss of cooling protection
- Trip from external protection, i.e., offshore application

8.4 INTERNAL FAULTS IN THE VSC SUBSTATION

The VSC substation design and the fault protection system must ensure that internal faults do not create any hazards.

8.4.1 Internal AC Bus Fault

The consequences of an ac fault may depend on the grounding philosophy of the scheme. The protection system has to be designed to cope with each particular fault scenario.

Mechanism: Insulation failure somewhere between the transformer secondary winding and converter switches, or failure of equipment connected to the ac bus.

Type: Permanent fault (even when self-restoring insulation breaks down).

Detected by: AC overcurrent protection.

Protective actions: Since a fault inside the converter is very serious, the converter must be tripped and the fault investigated.

8.4.2 DC Bus Fault

The consequences of a dc fault will depend on the grounding philosophy of the scheme. The protection systems must be designed to cope with each particular fault scenario.

Mechanism: Insulation failure between the dc connection and the VSC valves.

Type: Permanent fault (even when self-restoring insulation breaks down).

Detected by: Overcurrent protection.

Protective actions: Permanent blocking and tripping of the VSC substation from overcurrent protection. Since a fault inside the converter is very serious, the converter must be tripped and the fault investigated.

8.4.3 Component Failure

8.4.3.1 VSC Valve Failure (see Chapter 5)

Mechanism: Each VSC valve is normally provided with one or more redundant IGBTs. Therefore, operation can continue with one or more faulty IGBTs until the number of failed IGBTs in a valve exceeds the number of redundant IGBTs per valve. If the number of failed IGBTs exceeds the redundant ones, the risk of complete VSC valve breakdown is increased.

Type: Permanent fault.

Detected by: Appropriate monitoring of the switches. When too many component failures are detected, the converter is tripped with no further consequences.

Protective actions: Alarm for IGBTs failures. Trip of ac circuit breakers when the number of failed IGBTs in a valve exceeds the redundancy.

8.4.3.2 VSC DC Capacitor Failure

Mechanism: Progressive failure of VSC dc capacitor elements. Each capacitor is normally built using self-healing insulation, which disconnects faulty capacitor elements. The failure of some capacitor elements can be tolerated, but when elements fail the capacitance falls and the voltage distribution becomes non-ideal.

Type: Progressive, eventually leading to a permanent fault.

Detected by: A VSC is not as sensitive to VSC dc capacitance value as, for example, a tuned filter. Therefore, it may be acceptable to not have specific detection of the gradual failure of elements, but rather to rely on occasional off-line monitoring of the capacitance. As an alternative, the voltage across each capacitor could be monitored, since the dc voltage ripple will increase as the capacitance drops. However, in either case it is desirable to ensure that a decrease in capacitance due to aging of the VSC dc capacitor is taken into account in its initial value.

Protective actions: Trip of ac circuit breakers when a significant change in the VSC dc capacitance is detected.

8.4.3.3 Phase Reactor Failure

Mechanism: The phase reactors will normally be air-cored and air-insulated. Thermal overstressing and exposure to repetitive high frequency transient voltage may weaken the inter-turn insulation and lead to eventual turn-to-turn breakdown. Such faults are very difficult to detect on-line without the use

of thermal imaging. It is recommended that the reactors be carefully inspected at each maintenance outage.

Type: Permanent and progressive fault.

Detected by: If a turn-to-turn short circuit is undetected, the high temperatures that develop can lead to other turn-to-turn failures. Short-circuiting of a significant part of the phase reactor can lower the performance of the VSC.

Protective actions: Block the converters and trip the ac circuit breakers when a reactor fault is detected.

8.5 EXTERNAL FAULTS AND SWITCHING TRANSIENTS ON THE AC SIDE

The design of the VSC substation and its protection must ensure that the substation equipment does not suffer any damage from external faults and switching transients in the connected ac grid.

8.5.1 AC Voltage Dip

Mechanism: Fault in the ac network due to remote lightning strike, pollution, falling tree, external mechanical stress, etc.

Type: Non-permanent phenomenon, may be single- or multi-phased.

Detected by: AC overcurrent protection.

Protective actions: If the ac voltage drop is not too large, the overcurrent due to the voltage difference can be mitigated by the converter control. If the control fails, an overcurrent will appear and the overcurrent protection will stop the converter. The control system must then put the converter back in operation as soon as the ac voltage returns to an acceptable value.

8.5.2 AC Temporary Overvoltage

Mechanism: Loss of voltage control, load rejection.

Type: Temporary overvoltage.

Detected by: VSC dc capacitor overvoltage.

Protective actions: A very large overvoltage cannot be mitigated by the control system due to the free-wheeling diodes. In case of high and prolonged overvoltage, the converter will be tripped and blocked by the abnormal ac voltage protection system. However, dc voltage clamping, if used, can mitigate such overvoltages and thus reduce their consequences.

8.5.3 AC Lightning Overvoltage

Mechanism: Lightning strike to overhead lines in the ac network close to the converter.

Type: Fast-front overvoltage.

Normally, phase reactor, clamping elements, shunt ac filters and interface transformer (if in use) will significantly prevent any fast-front overvoltage from occurring across the converter equipment.

Detected by: Surge arrester operation or operation of digital transient recorder, if fitted.

Protective actions: The equipment must be rated for this duty, taking into account the overvoltage protective devices used (i.e., surge arresters).

8.5.4 AC Switching Overvoltage

Mechanism: AC line energisation, etc.

Type: Slow-front overvoltage.

Detected by: Surge arrester operation or operation of digital transient recorder, if fitted.

Protective actions: The equipment must be rated for this duty, taking into account the overvoltage protective devices used (i.e., surge arresters).

8.5.5 AC Voltage Phase Shifting

Mechanism: Loss of a generator or a loss representing a non-negligible portion of the total load (especially in weak or small networks). Change in the ac network topology.

Type: Fast phase and frequency change.

Detected by: A sudden change of the network voltage phase will result in a sudden change of the phase angle between the network voltage and the voltage generated by the converter. This phase change will lead to an active power step that will be controlled and compensated by the converter control, which requires a fast-acting PLL (phase lock loop controller).

Protective actions: The control system should be able to handle the power step caused by the phase shift. If the control fails to do so, the subsequent overcurrent will be detected by the overcurrent detection and result in VSC blocking and tripping.

8.5.6 AC Voltage Phase Unbalance

Mechanism: Unbalanced load or fault, equipment failure.

Type: Different voltages on the three phases.

Detected by: The converter must be able to operate with the specified maximum phase unbalance. Depending on the requirements, ac voltage phase unbalance protection may be necessary, since prolonged operation with severely unbalanced ac voltage may be unacceptable.

Protective actions: Alarm, block and trip, as necessary.

8.5.7 DC Overvoltage

Mechanism: A VSC dc capacitor overvoltage may be caused by an external overvoltage, by a sudden blocking of the inverter terminal, or by incorrect energisation of a VSC substation, as, for example, during the fault clearance of a local ac system short circuit when dc voltage drops to zero and the IGBT switches are not operational (e.g., if their gate power supply has been depleted). This event can be prevented in design by dc circuit discharge or dc voltage clamping devices.

Type: Temporary or permanent.

Detected by: Measurement of the VSC dc capacitor voltage.

Protective actions: If in use, dc voltage clamps across the VSC dc capacitors can be operated to reduce the overvoltage.

8.5.8 Post-Fault Recovery

The VSC can be so designed that a non-permanent fault should not cause its tripping. If the VSC is not designed to remain in operation during faults, the restarting of the converter after a non-permanent fault is a very important issue. In some cases, for example when VSC Transmission is used as the power evacuation of a wind farm, the maximum permissible duration of the temporary transmission stop is limited by the characteristics of the wind generators. After a non-permanent fault, the VSC Transmission should restart quickly to allow the wind farm to stay connected. If the VSC Transmission stays stopped too long, the wind generator will be tripped by its over-speed protection, resulting in the tripping of the whole wind farm (which means many minutes of lost wind power generation).

8.6 FAULTS ON THE DC TRANSMISSION LINE OR CABLE

8.6.1 DC Cable Fault

Mechanism: Cable or junction failure, external mechanical stress.

Type: Permanent fault, for which repair is needed.

Detected by: DC cable faults are detected by measuring the dc voltage and current, both amplitude and rate of change.

Protective actions: Since any fault in a cable must be thoroughly investigated and will most likely require a lengthy repair, the dc link has to be tripped when such faults are detected. It is therefore very important to correctly detect these faults.

8.6.2 DC Overhead Line Fault

Mechanism: Insulation failure between one dc conductor and ground or between the two dc conductors, due to lightning strike, trees, pollution, external mechanical stress, etc.

Type: Can be a non-permanent fault, but may be permanent if the dc insulators have been damaged.

Detected by: DC overhead line faults are detected by measuring the dc voltage and current, both amplitude and rate of change.

Protective actions: It should be noted that when insulation breaks down on overhead transmission lines, the VSC's free-wheeling diodes will continue to feed current into the fault even if the converter is blocked. This means that besides blocking the converters, they also need to be isolated from the ac system to enable the air insulation to de-ionise. Another method is to introduce dc breakers and open these when a fault is detected. If dc breakers are used, the outage time can be shorter than when the ac breakers have to be tripped.

8.6.3 DC Bus Overvoltage (dc overhead line only)

Mechanism: Lightning strike close to the converter.

Type: Fast-front overvoltages.

Detected by: Surge arrester operation or operation of digital transient recorder, if fitted.

Protection measures: The equipment must be rated for this duty, taking into account the overvoltage protective devices used (i.e., surge arresters).

8.6.4 DC Overvoltage

Mechanism: Sudden blocking of the remote converter and failure of the VSC dc voltage controller.

Type: Similar to the consequences of an ac overvoltage, the dc overvoltage can normally be mitigated by converter control action.

Detected by: DC bus voltage measurement.

Protective actions: In case of high and persistent overvoltage, the converter will be stopped by the abnormal voltage protection system. However, dc voltage clamping devices help mitigate such overvoltages.

8.6.5 Other Protection Actions

Other important protective actions are:

- Loss of cooling protection
- DC line/cable earth fault protection/supervision
- Frequency protection
- Impedance relay protection
- Fire protection
- Mechanical protection

Additional protection may be necessary, depending on the application, as, for example, when the VSC Transmission is feeding an isolated ac power grid with insufficient short-circuit capacity. If the VSC cannot provide sufficient fault current to operate the overcurrent protection in an isolated ac grid, it may be necessary to provide an external trip signal to the VSC substation from the isolated ac grid.

8.7 REFERENCES

- [8-1] Tang, L., Ooi, B.T., "Protection of VSC Multi-terminal HVDC against DC Faults." IEEE 33rd Power Electronics Specialists Conference (PESC), Queensland, Australia, Vol. 2, pp. 719-724, 2002.

9. HARMONIC PERFORMANCE

9.1 INTRODUCTION

Many aspects of the harmonic performance of a VSC Transmission scheme are similar to those of an LCC HVDC scheme. The main difference between the two comes from the LCC HVDC scheme being based on a current sourced line commutated converter, whilst the VSC Transmission scheme is based on a voltage sourced self-commutated converter.

For the purpose of this chapter the converters are treated as ideal sources. For real systems, however, the impedances and susceptances are finite. Consequently, the simple calculations presented here may not give results with acceptable accuracy.

Voltage sourced converters (VSCs), like line commutated converters, generate harmonics on both the ac and dc sides. Measures must be taken to limit the amplitude of the harmonics entering the ac network and the dc line. The effects may not be confined to the vicinity of the converter station, but could be propagated over great distances. The main methods of reducing the harmonics to acceptable levels are:

- Pulse width modulation (PWM) techniques
- Multi-pulse techniques
- Multi-level techniques
- Harmonic filters (series and/or shunt combinations)
- Combinations of the above

In line commutated converters, the ac filters serve the dual purpose of diminishing ac harmonics and supplying reactive power at fundamental frequency. Since a VSC can be designed to operate at any desired power factor, the latter requirement is not essential, and therefore converter configurations are chosen to achieve acceptable harmonic levels for utility application with small harmonic filters. Series or shunt filters, or a combination of series and shunt filters, may be necessary to achieve the harmonic performance set by the network operator. In addition to filters, since the VSC is an ac voltage source with low internal impedance, a series inductive interface with the ac system (usually a phase reactor and/or a transformer) is essential. On the dc side, the VSC dc capacitor diminishes harmonics; nevertheless, filters may be required.

The magnitude and order of the voltage harmonics generated or absorbed by the VSC on the ac side depend on its design and configuration. The magnitude of the current harmonics injected into or absorbed from the ac bus depends on the voltage harmonics and the frequency-dependent characteristics of the ac system impedance at the point of connection of the VSC (point of connection, or POC), as well as on the harmonic impedance of the VSC substation. On the dc side, the main problem is the interaction of the current and voltage harmonics produced along the line with the telecommunication circuits in a frequency range up to 5 kHz (voice communication spectrum). Harmonics in the radio frequency (RF) band, several orders above the fundamental frequency, are a source of electromagnetic disturbance and may create electromagnetic interference (EMI). This chapter examines the basic of harmonics generated by the different configurations of VSCs, their effects on the utility power system, and their interference with telecommunication systems.

9.2 WAVE DISTORTION

The individual voltage distortion factor (D_v), total voltage distortion factor (D_{rss}), telephone harmonic form factor (THF), telephone influence factor (TIF) and total harmonic current factor (IT), as defined in CIGRÉ Publication 139, *Guide to the Specification and Design Evaluation of AC Filters for HVDC Schemes* [9-1], are relevant also to VSC Transmission schemes.

It should be noted that with VSC technology it is relatively easy to shift the amplitude of harmonics to higher orders of the fundamental frequency. When setting the distortion limits for a VSC Transmission scheme, it may be appropriate to assess harmonics to a higher order than has been the case for LCC HVDC schemes, e.g., to increase the order to be included from the 50th harmonic to, say, the 100th harmonic. Naturally, if the impact of such high frequency harmonics is considered to have negligible impact on the performance of equipment in the network, this increase is unnecessary.

9.3 FUNDAMENTAL AND HARMONICS

9.3.1 Three-Phase 2-Level VSC

A 2-level converter is shown in Figure 9.1.

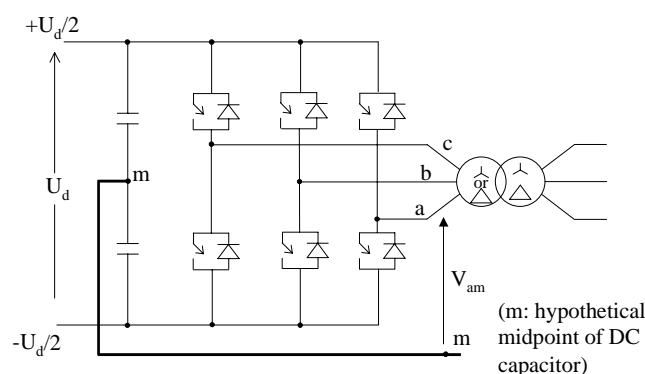

Figure 9.1: 2-level VSC

If fundamental frequency switching of the valves is used, then the harmonics for a VSC are the exact dual of those for a line commutated current sourced converter with zero commutating reactance. Thus, as a first approximation, the VSC (excluding phase reactor and dc capacitor) appears as a harmonic voltage source when viewed from the ac side, and as a harmonic current source when viewed from the dc side. The waveshape can be analyzed in exactly the same way as for an LCC HVDC scheme.

In practice, fundamental frequency switching is not used for 2-level converters for VSC Transmission applications, due to the performance restrictions associated with this method of control. Instead, higher frequency switching is used to create the ac waveshape, as explained in Chapters 3 and 4.

9.3.2. Pulse Width Modulation (PWM)

The ac waveshape at a VSC phase unit output may consist of a sequence of square waves, as shown in Figure 9.2. Many different modulation methods can be used to control the converters to achieve a specific waveshape. The most commonly used methods are:

- Carrier-modulated method (voltage reference as sinewave or other with a triangular waveshape) [9-19]
- Selective harmonic elimination modulation (SHEM) [9-19], [9-20], [9-21], [9-23]

Other modulation methods are also available, such as:

- Space vector [9-23], [9-22]
- Hysteresis [9-23], which is often linked to “sliding mode” techniques

In this report only two methods will be discussed. The first is the carrier-modulated method, which uses the comparison of the sinewave with a triangular waveshape as the carrier; the second is SLEM, which uses pre-calculated switching angles.

Figure 9.2 refers to the first method, i.e., the carrier-modulated method. Figure 9.2a shows the control signals (the carriers and the voltages references as sinewave) for a PWM VSC. Figure 9.2b shows the resulting voltage V_{am} at the ac terminal a, with respect to a hypothetical midpoint m of the dc capacitor. In this example the frequency of the carrier (triangular wave signal) is nine times the fundamental frequency.

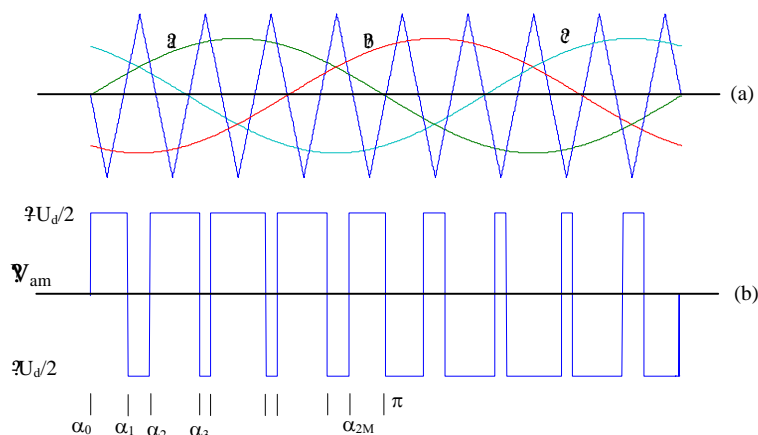

Figure 9.2: a) Control signals for a PWM VSC
 b) Phase *a* output voltage (V_{am})

In the example of Figure 9.2b the angles $\alpha_0, \alpha_1, \alpha_2, \dots, \alpha_{2M}, \pi$ define the switching times. There are $2M+1$ (=9) switching times per half cycle. The amplitudes of the harmonics of the waveform of Figure 9.2b are given by:

$$V_h = 2U_d/h\pi \left[1 + \sum_{K=1}^{K=2M} (-1)^K \cos h\alpha_K \right] \quad \text{Equation 9.1}$$

If the triangular waveshape (the carrier) frequency is an odd integer multiple of the fundamental frequency, the waveform of Figure 9.2b does not contain even order harmonics. In a three-phase bridge circuit, all of the triplen harmonics, i.e., 3rd, 9th, ... are eliminated in the phase-to-phase voltages, provided that the ac system voltages are balanced and free of background harmonic distortion. Also, if the triangular waveshape frequency is a multiple of 3, the harmonics of the order of the triangular waveshape frequency are cancelled in the phase-to-phase and phase-to-floating neutral voltages (three-phase converter considered). The order of harmonics present in this type of PWM VSC is determined by $K_1m \pm K_2$, where K_1 is the frequency multiplier of the triangular waveshape frequency, m is any integer and K_2 is an even integer (zero is excluded for both m and K_2). Practically, K_2 need only be taken up to 2, after which the magnitude of that harmonic order becomes rather small.

Figures 9.3a and 9.3b show the typical harmonic spectra of the voltage waveforms for phase-to-floating neutral and phase-to-phase, respectively, for a 2-level VSC using PWM switched waveforms with a carrier-based control method using 21 times fundamental frequency and assuming infinite dc capacitance (i.e., no dc voltage ripple). These harmonics spectra would be changed under different specific operating conditions.

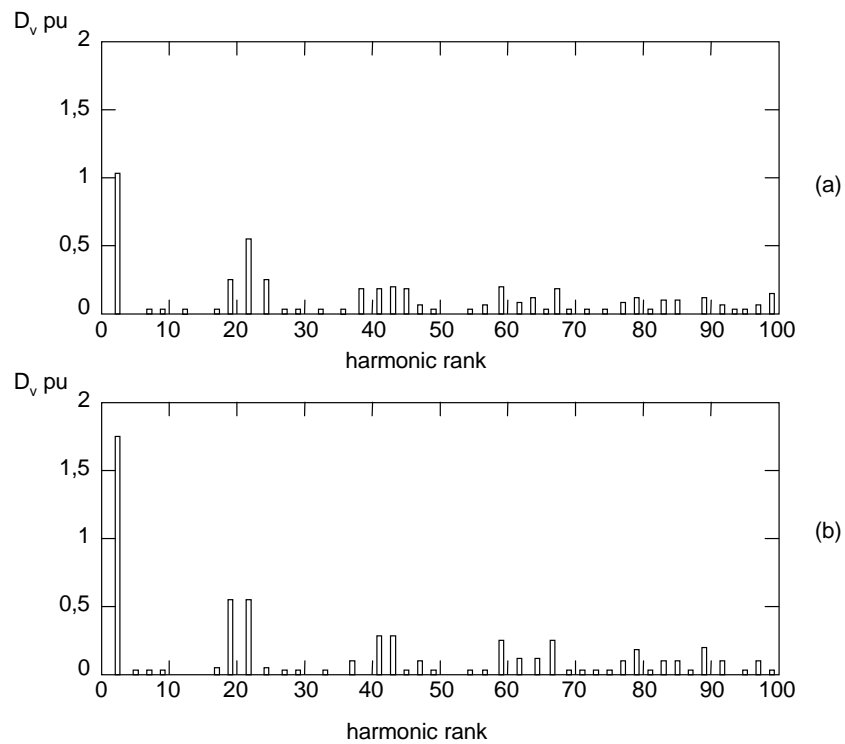

Figure 9.3 Voltage harmonics spectra of a 2-level VSC with carrier frequency at 21st harmonic

- (a) Phase-to-floating neutral voltage amplitude versus harmonic rank
- (b) Phase-to-phase voltage amplitude versus harmonic rank

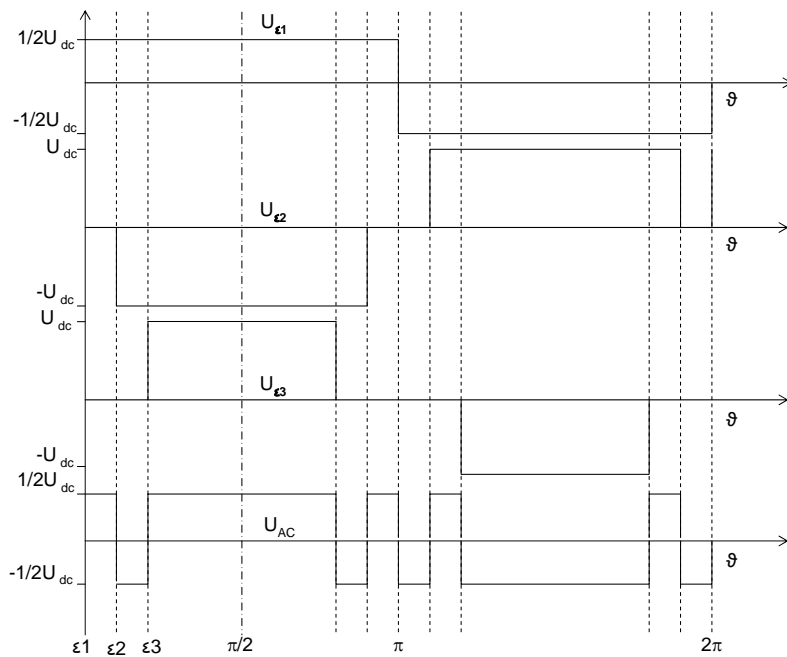

Figure 9.4: Graphical explanation of the SHEM principle (5th harmonic elimination)

Figure 9.4 refers to the second method, the selective harmonic elimination method, or SHEM. The waveform has half-wave and quarter-wave symmetry. It can be shown that with proper variation of specific switching time in the square wave and preserving the half-wave/quarter-wave symmetry, it is possible to not only control the fundamental frequency component, but also to eliminate selected harmonics. With M number of independent switching angles per quarter period, there are M degrees of freedom. One of these degrees of freedom can be used to control the fundamental component, leaving the other $M-1$ degrees of freedom to eliminate $M-1$ selected harmonics. For Figure 9.4, $M=2$ and therefore control of the switching could be used to eliminate one harmonic, e.g., 5th.

Figure 9.4 is a graphical presentation of the basic principle for the elimination of the 5th harmonic.

Substituting $V_h = 0$ in Equation 9.1 for the specific harmonics to be eliminated, $M-1$ equations can be assigned, the remaining equation is allocated to determine the required value of the fundamental voltage. The M equations determine the M angles $\alpha_1, \alpha_2, \dots, \alpha_M$.

9.3.3 Multi-Pulse and Multi-Level Converters

Multi-pulse and multi-level converter topologies can also be used to reduce the harmonic output, as explained in Chapter 4. The harmonics are calculated by Fourier analysis of the individual waveshapes.

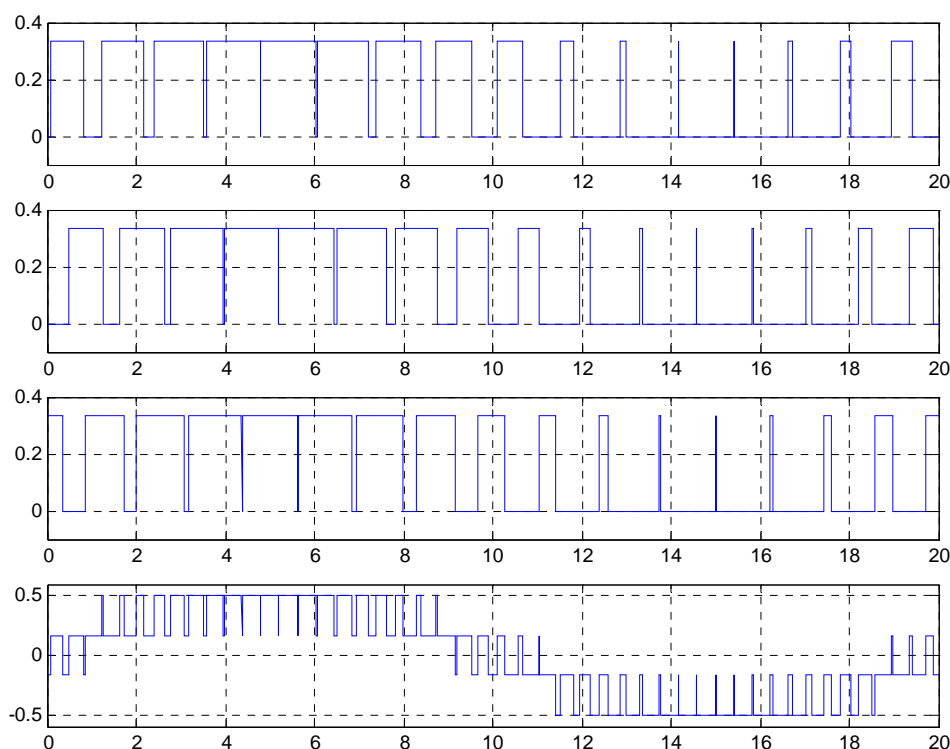

Figure 9.5: Voltage generated by one phase unit, 4 levels VSC voltage (y axis, pu) versus time (x axis, ms). From upper to lower window:

- Cell voltage for upper cell, not referenced to dc midpoint
- Cell voltage for middle cell, not referenced to dc midpoint
- Cell voltage for lower cell, not referenced to dc midpoint
- Resulting voltage at phase unit output (phase to midpoint of DC capacitor).

As an example, Figure 9.5 refers to one VSC phase unit of a 4 ($n=4$) level multi-level topology. This VSC phase unit includes three (corresponding to $n-1$) cells, each having the same equivalent dc voltage (equal to $U_d/3$), and each being controlled under carrier-modulated method with a suitable phase shift

from one to another. Figure 9.5 shows the three voltages (in the three upper windows) delivered by the three corresponding cells, and the voltage at the phase unit output (lower window), which is the sum of the above three waveshapes.

Note: the term “cell” is specifically used when multi-level topology is considered. A cell includes two complementary switches combined to their dc floating capacitors. For example, a 4-level multi-level topology includes three cells in series per VSC phase unit.

The harmonics at the phase unit output are determined as the sum of harmonics generated by the three cells. Obviously, this sum must take into account both amplitude and phase of harmonics at each rank. The harmonic produced by each cell is defined according to the classical Fourier technique for each rank, either through both a_h and b_h (i.e., the complex value c_h), or through both amplitude and phase.

9.3.4 Comparison of the Harmonic Content at the AC Terminals of the VSC Valve Units

As a first approximation, VSCs can be characterised according to two key features:

1. « n » : number of levels (or equivalent number of levels)
2. Type of modulation pattern

As a first approximation “n” is an indication of the harmonic voltage distortion at the ac converter valve unit’s output. The harmonic distortion here includes all harmonics up to infinity:

Table 9.1 Typical harmonic distortion at the VSC valve ac terminals (thd)

“n”	Topology Example	Typical total harmonic distortion at the valve terminals (“thd”)
2	2-level converters. 6-pulse converters	50%
3	3-level neutral point clamped converters 3-level floating capacitor converter 12-pulse converters	30%
4	4-level converters (multi-level topology) 3-level converters combined by transformers	20%
5	5-level converters (multi-level topology)	15%

Note: The figures above related to “thd” give an idea of the total harmonic content with respect to the amplitude of fundamental voltage, i.e.,

$$thd = (U_{h_rms})/U_{1_rms} = \left(\sqrt{\sum_{h=2}^{\infty} U_h^2} \right) / U_1 \tag{Equation 9.2}$$

where:

- h is the harmonic number
- U_{h_rms} is the rms value of the h^{th} harmonic voltage content in U_{conv}
- U_{1_rms} is the fundamental frequency component of U_{conv}

The main assumptions in Table 9.1 are:

- Phase-to-phase voltage considered
- Carrier modulated method with triple harmonic injection
- Harmonics up to infinity included
- Maximum modulation index, i.e., 100%

The theoretical “thd” determined using these assumptions are 52%, 30%, and 19% for 2, 3 and 4 levels, respectively.

The harmonic distortion is also affected by the modulation index and the switching frequency, but these factors have a second order effect compared to the “n” parameter.

The modulation pattern influences the distribution of harmonics versus frequency. As an illustration, Figure 9.6 shows the phase-to-phase voltage spectrum (at phase unit output) of a 2-level VSC, for full wave modulation and for carrier modulated method on the upper and lower graphs, respectively.

As shown in Figure 9.6, the full-wave pattern, i.e. square wave operation, produces relatively high amplitude low order harmonics, with the amplitude of higher order harmonics falling as the order increases. The carrier-modulated method is usually used for medium or high switching frequency (say, ranging from 600 Hz to 2000 Hz, i.e., harmonic rank from 12 to 40 on a 50-Hz basis). Compared to the full wave method, this method moves the low order harmonics to higher orders, but the “thd” remains largely unchanged, or is perhaps even slightly increased.

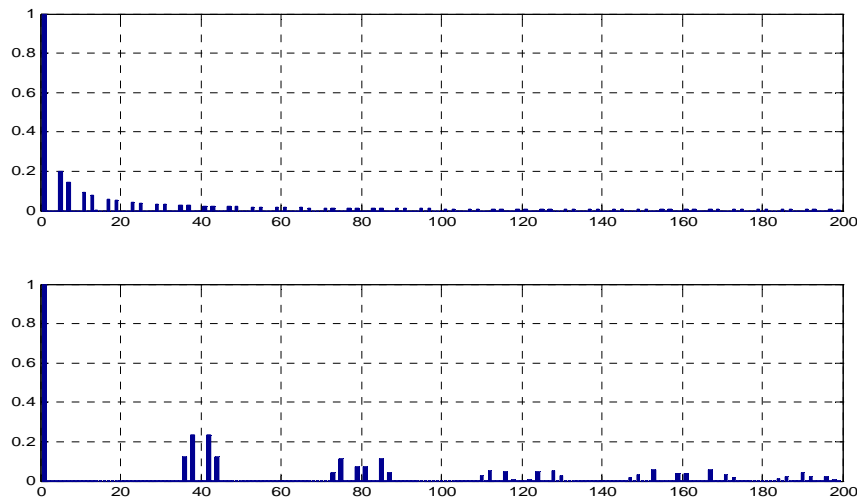

Figure 9.6: Spectrum of phase-to-phase voltage at a 2-level phase unit output, amplitude (y axis, pu U₁ based) versus harmonic rank (x axis, 50-Hz based)

- Upper graph: Full wave modulation
- Lower graph: Carrier-modulated method at 2kHz

The SHEM pattern is usually used at low switching frequency (say, ranging from 300 Hz to 700 Hz, i.e., harmonic rank from 6 to 14 on a 50-Hz basis) to eliminate low-order harmonics. The specific harmonics can be determined by design, but the “thd” remains largely unchanged. The corresponding voltage spectrum can be considered as a mixture of the two spectra mentioned for full wave and carrier modulated methods, but is obviously directly dependent on the selected harmonics to be rejected.

9.4 HARMONIC VOLTAGES ON POWER SYSTEMS DUE TO VSC OPERATION

One possible method for calculating the harmonic performance of the VSC is to consider it to be a harmonic generator of equivalent voltage E_n at each individual harmonic. At the point of common connection (POC) of the VSC and the power system, the equivalent circuit is shown in Figure 9.7, where $Z_{s(h)}$ is the system impedance at the harmonic h and $Z_{(h)}$ is the harmonic impedance of the VSC, including the interface transformer, phase reactor and filters.

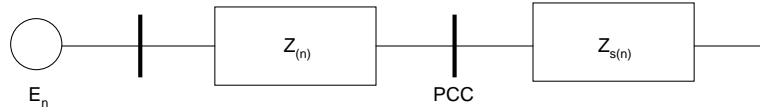

Figure 9.7: Equivalent circuit at the POC of the VSC

The harmonic voltage amplitude of order h at the POC is given by:

$$V_h = E_h \left| \frac{Z_{s(h)}}{Z_{s(h)} + Z_{(h)}} \right| \quad \text{Equation 9.3}$$

Since both $Z_{(h)}$ and $Z_{s(h)}$ are complex impedances, resonances may occur. Therefore, it is essential to have knowledge of the utility harmonic system impedance at the POC. The frequency-dependent system impedance characteristics at the POC are especially affected by:

- The impedance of transmission lines, cables and transformers
- Capacitor banks and filters installed for voltage control
- Systems loading level and dynamic characteristics of the load.

A good utility practice is to utilize a single-phase representation of the utility system to calculate the frequency dependent system impedance for various orders of harmonics. These computer simulations need to include accurate representations of the above mentioned system components. A three-phase representation including the ground paths may be used in cases where it is important to estimate the effects of:

- Telephone interference (where the residual current harmonics are significant)
- Single-phase capacitor banks
- Single-phase or unbalanced harmonic sources
- Triplen harmonic voltage sources

For satisfactory VSC design and rating, the following information at the POC is also important:

- Permissible harmonic emission level of the VSC
- The characteristics of any other harmonic emitting equipment in the vicinity
- Existing background harmonic levels and trends in time (daily, weekly, monthly, seasonal patterns)
- Harmonic measurement and evaluation procedures

Close attention to the above factors during the design stage can avoid subsequent harmonic problems that can lead to system/VSC operating restrictions or the need for additional harmonic filters.

Where the system impedance characteristics are not known, it may be necessary to assume that the system impedance can have any value within a given area. One approach is to describe this as a circle in the complex impedance plane, as shown in Figure 9.8.

Typical values for R_2 and θ are 200-1000 Ohms and 75° - 85° , respectively for a 400kV system. R_1 represents the minimum value of network resistance. Usually higher damping is inherent in the ac system for higher order harmonics.

From the knowledge of harmonic distortion limits and existing harmonic levels/trends, utilities can make an assessment of the acceptable contribution by the VSC to harmonic distortion at the POC. Guidance on recommended practices and requirements for harmonic control for utilities are provided in the international standards and recommendations [9-1], [9-3], [9-4], [9-9], [9-18].

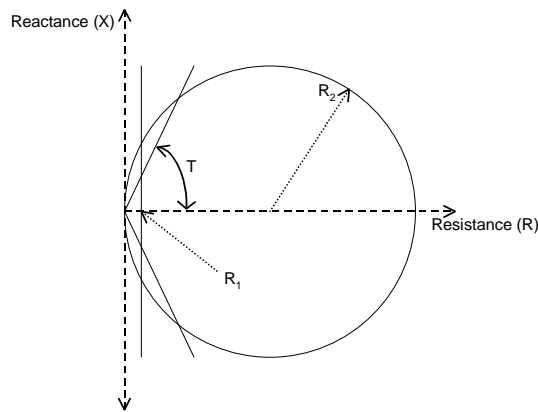

Figure 9.8: Boundaries of harmonic impedance loci at the POC

9.5 DESIGN CONSIDERATIONS FOR HARMONIC FILTERS (AC SIDE)

If the evaluation indicates that the VSC contribution to harmonics at the POC will exceed the permissible level, harmonic filters must be designed and installed to keep the harmonics within the required limits. The filter configuration for the VSC is determined in a similar manner as those for LCC HVDC (see WG 14.30 *Specification and design evaluation of ac filters for HVDC systems*).

Filtering for a VSC is normally easier than for an LCC HVDC scheme, since the dominant harmonics to be filtered may be at higher frequency. However, it is desirable to keep the filter Mvar rating small, as the VSC does not require reactive power compensation as is needed for an LCC HVDC scheme. The filter arrangement must also be different than that of an LCC HVDC scheme, since the converter is a voltage source and cannot be directly connected to another voltage source or to low impedance filters. Thus, a series reactance is needed, the value of which is to a certain extent dependent on the level number “N”, as well as on the switching frequency. This function is normally performed by the phase reactor, which also acts as part of the dV/dt protection of the ac side equipment. A shunt filter is normally connected on the ac system side of the phase reactor in order to reduce harmonic levels to the desired value. Often the interface transformer provides further series reactance, but if a transformer is not needed, an additional series reactor may be provided as a final filtering step. Further filtering may be connected on the ac system bus, if necessary.

The following considerations should be taken into account when the rating of the filter is specified:

- All VSC operating conditions
- The harmonic currents which may flow into the filters from other harmonic sources
- The effect of unbalance conditions of system voltages
- Detuning due to frequency deviation, ambient temperature, and failure of capacitor units or elements
- System harmonic impedance characteristics

The protection scheme for the filters may include capacitor unbalance protection, overcurrent protection, overvoltage protection, and differential protection.

9.6 DC SIDE FILTERING

If the VSC is part of a dc transmission scheme connected by a dc overhead line, or a combination of dc cable and dc overhead line, its dc-side harmonics may interfere with other equipment and substations near the transmission line. If there are communication cables close to dc cables over a long distance,

the potential interference between these cables must be considered. The frequencies used in commercial voice transmission range from 200 to 5000 Hz. Telephone noise evaluation is performed according to a THF weighting factor. The coupling between power circuits and telephone circuits is through both electric and magnetic fields. However, unless the spacing between the two circuits is small, the magnetic coupling predominates and the electric coupling is negligible. For bipolar dc lines, this coupling is usually calculated using the “Equivalent Disturbing Current” [9-3].

Weighting factors and limits for telephone noise are given in CCITT directives. If filtering is required on the dc side, a common mode reactor, dc reactor, or a dc filter can also be used to perform the role of RF filtering.

Notes:

CCITT: Consultative Committee for International Telegraph and Telephone; a predecessor organization of the ITU-T.

ITU-T: Abbreviation for International Telecommunication Union—Telecommunication Standardization Bureau. The Telecommunications Standardization sector of the International Telecommunication Union (ITU).

ITU-T is responsible for studying technical, operating, and tariff questions and issuing recommendations on them, with the goal of standardizing telecommunications worldwide. The ITU-T combines the standards-setting activities of the predecessor organizations, formerly called the International Telegraph and Telephone Consultative Committee (CCITT) and the International Radio Consultative Committee (CCIR).

9.7 REFERENCES

- [9-1] CIGRÉ WG 14.30, “Guide to the Specification and Design Evaluation of AC Filters for HVDC Schemes.” CIGRÉ Publication No. 139.
- [9-2] Hingorani, N.G., Gyugyi, L., *Understanding FACTS. Concepts and Technology of Flexible AC Transmission Systems*. IEEE Press, New York, 2000.
- [9-3] CIGRÉ WG 14.03, “DC side harmonics and filtering in HVDC transmission systems.” CIGRÉ Technical Brochure No. 92, 1995.
- [9-4] JTF 02 of CIGRÉ WG 14.03 and CCO2 (CIGRÉ 36.05/CIRE2 2), “Connection of harmonic producing installations in AC high voltage networks with particular reference to HVDC. Guide for limiting interference caused by harmonic currents with special attention for telecommunication systems.” Electra reference No. 159, 1995.
- [9-5] Mohan, M., Undeland, T.M., Robbins, W.P., *Power Electronics. Converters, Applications and Design*. John Wiley & Sons, Hoboken, NJ, 1995.
- [9-6] CIGRÉ WG 15.19, “Static Synchronous Compensator (STATCOM).” CIGRÉ Technical Brochure No. 144, 1999.
- [9-7] *IEEE Recommended practices and requirements for harmonic control in electrical power systems*, IEEE Standard 519-1992 (replacing IEEE Standard 519-1981).
- [9-8] *Voltage characteristics of electricity supplied by public distribution systems*, European Standard EN 50160 (1995).
- [9-9] *Electromagnetic compatibility (EMC) - Part 2: Environment - Section 1: Description of the environment - Electromagnetic environment for low-frequency conducted disturbances and signalling in public power supply systems*. IEC Standard 61000-2-1:1990.
- [9-10] IEC Technical Report 61000-3-6:1996. *Electromagnetic compatibility (EMC) - Part 3: Limits - Section 6: Assessment of emission limits for distorting loads in MV and HV power systems*.
- [9-17] Xu, W., Mansour, Y., Siggers, C., Hughes, M.B., “Developing Utility Harmonic Regulations based on IEEE STD 519: BC Hydro’s Approach.” *IEEE Transactions on Power Delivery*, Vol. 10, No. 3, pp. 1423-1431, July 1995.

- [9-18] IEEE, "Specification of Harmonic Filters for HVDC Station." IEEE catalog number 93 THO 609-8 PWR.
- [9-19] Wuest, D., "An improved PWM optimization method for a reactive power compensator with self-commutated inverter." IEEE, 1991.
- [9-20] Attaianese, C., Ometto, A., Rotondale, N., Tomasso, G., "Optimal modulation strategy for active front-end inverter feeding induction motors." *Proceedings, IEEE International Symposium on Industrial Electronics (ISIE 2002)*, Vol. 4, pp. 1253-1258.
- [9-21] Karshenas, H.R., Kojori, H.A., Dewar, S.B., "Generalized techniques of selective harmonic elimination and current control in current source inverters/converters." *IEEE Transactions on Power Electronics*, Vol. 10, No. 5, pp. 566-573, September 1995.
- [9-22] Blaabjerg, F., Freysson, S., Hansen, H-H., Hansen, S., "A new optimized space vector modulation strategy for a component minimized voltage source inverter." *IEEE Transactions on Power Electronics*, Vol. 12, No. 4, pp. 704-714, July 1997.
- [9-23] Wang, Q., Chang, L., "PWM control strategies for wind turbine inverters." *Proceedings, IEEE Canadian Conference on Electrical and Computer Engineering*, Vol. 1, pp. 24-28, May 1998.
- [9-24] Enjeti, P.N., Ziogas, P.D., Lindsay, J.F., "Programmed PWM Techniques to eliminate harmonics: a critical evaluation." *IEEE Transactions on Industry Applications*. Vol. 26, No. 2, pp. 302-316, March/April 1990.

10. ENVIRONMENTAL IMPACT

10.1 INTRODUCTION

This chapter covers the main environmental impact resulting from the development of a VSC substation. The environmental aspects discussed are audible noise, visual impact, EMF and EMC. Other factors of a more generic character that result from VSC substation development are not covered, nor are the impacts from the development of a cable or overhead line system. End-of-life issues, like recycling and disposal, are similar to those for an LCC HVDC scheme and are discussed in Chapter 13, as are power losses.

10.2 AUDIBLE NOISE

The CIGRÉ report produced by WG 14-26, “HVDC Stations audible noise” [10-1], covers in a comprehensive manner the audible noise related to line commutated HVDC converter stations, and is applicable also to VSC Transmission. Audible noise theory is, therefore, not covered here.

The noise characteristics of the cooling equipment and auxiliaries are similar to those used in a conventional ac substation. In existing VSC Transmission schemes, the noise characteristics of the transformer are similar to those of a substation transformer, as the use of filters on the converter side results in a very low level of harmonics in the transformer. For other designs the noise characteristics may be different. The filters, VSC valves, phase reactor and VSC dc capacitors typically have noise components at higher frequency than for an LCC HVDC scheme.

The main sound-emitting sources in a VSC substation are presented in Table 10.1, along with the sound power levels of typical components.

Table 10.1: Typical noise emission levels for a 300-MW VSC

	Component Sound Power $L_{W(A)}$ in dB(A) without noise attenuation	Component Sound Power $L_{W(A)}$ in dB(A) with noise attenuation
Interface transformer	90-110	60-90
Harmonic filters	80-100	70-90
Capacitors	60-90	55-80
VSC valve	60-100	50-70
Cooling equipment	75-100	70-90
Auxiliary equipment	60-90	50-70

Noise attenuation can be achieved by a number of reduction measures that can be incorporated into the design of a VSC station. For many components, such as transformers, cooling equipment and auxiliaries, the measures taken to reduce noise are similar to those for a conventional ac substation. Table 10.1 shows typical sound power levels when noise mitigation is applied on the components. The need for such mitigation will depend on local environmental regulations and any specific licensing requirements or conditions.

An effective reduction measure is to locate noise producing ac and dc components inside buildings or enclosures designed for acoustic attenuation. Whether this measure is appropriate depends on the trade-off between the noise requirements, the amount of noise reduction needed, the visual impact, the cost of other attenuation measures, and the value of the other advantages that would be obtained by locating the equipment indoors. If an indoor design is chosen, the measured sound pressure at the fence (30 m from VSC building) is typically damped by 30 dBA.

In general, noise abatement measures should be developed to meet specific national requirements and regulations.

National regulations, such as the British Standard [10-2], establish the noise level at which new noise sources may provoke complaints. It advises that where there is a difference of around +10 dB or more, complaints are likely, whereas a difference of around +5 dB is of marginal significance. Other national regulations, like that of Norway [10-3], define the highest acceptable sound level, which for a quiet area during night time is 35 dBA, and for rural areas 40 dBA. If the noise limit is of a tonal character, the acceptable noise levels should be reduced by 5 dBA.

10.3 VISUAL IMPACT

The visual impact of a VSC station is highly dependent on the specification and the manufacturer's particular design. Typically, a manufacturer will have a basic, least-cost design for a scheme. The basic design will take into account the need for maintenance access and all operational requirements. The visual impact can be improved relative to the basic design, e.g., by architectural features or screening. Therefore, in order to develop a VSC project, it is important that the developer has a conceptual design that can be used in the pre-engineering phase as input to the project development. In addition, it may be necessary to have a good descriptive VSC design as input in the early stage of the licensing process.

Pictures of existing VSC Transmission substations can be seen in Appendix A. Typically, a VSC substation will have a considerably smaller footprint than an LCC HVDC substation, since relatively small ac harmonic filters are required in a VSC Transmission scheme, and these may not need to be switchable. A VSC substation's footprint may be 25 – 40% of the size of a similarly rated LCC HVDC substation.

10.4 ELECTRIC AND MAGNETIC FIELDS (EMF)

The electric and magnetic fields (EMF) associated with a VSC scheme can be separated into ac and dc fields. The ac fields are produced by the ac components of the substation, and the connection between the VSC and the ac grid. The dc fields (also referred to as static fields) are produced by the cable/OH line, by connections to the dc equipment, and by the dc equipment itself.

In general, the electric and magnetic fields around a VSC facility, including the substation, connections and dc overhead line or cable, are similar to those for an LCC HVDC scheme.

10.5 ELECTROMAGNETIC COMPATIBILITY (EMC)

The operation of high-voltage electrical equipment can generate electromagnetic fields over a wide range of frequencies, from power frequency to radio frequencies. It is possible for electrical or electronic equipment in the vicinity of such electromagnetic fields to be affected, or to have their proper operation interfered with. Interference limits imposed on facilities typically consider:

- Radio interference (RI)
- Television interference (TI)
- Telephone interference (see Chapter 9)
- Power line carrier interference (see Chapter 9)

The commutation frequency of a VSC is typically in the range of 1 kHz, and the normal associated harmonic level is usually in the 9 kHz range. However, VSC switching actions produce distortions. VSC valve switching can generate high frequency emissions up to several hundred MHz. The SVC design must ensure that such noise does not cause unacceptable interference for others. Different mitigation methods can be employed, such as proper grounding, the use of passive radio interference filters, and shielding of the sources by EMC barriers.

Radio interference is associated with noise in the frequency range of 50 kHz to several hundred Mhz. Television interference, on the other hand, results from noise in the frequency range 54 MHz to 1 GHz.

Consequently, the whole frequency range up to 1 GHz must be taken into account when designing the VSC substation.

Electrical interference and noise are transmitted in two forms: radiated and conducted. For the VSC, conduction on power lines is a more significant source than radiation. Housing a VSC in a metal enclosure generally reduces the radiated component of disturbances.

The conducted phenomena consist of two categories, commonly known as the differential mode and the common mode. The differential-mode disturbance is a current or a voltage measured between the power lines of the VSC, while the common-mode is a current or a voltage measured between the power lines and ground. Any filter design has to take into account both modes of noise.

The path of the common-mode disturbance is through stray capacitance. These stray capacitances exist between any system components and ground. In close proximity to the source, other predominant coupling paths should be considered, such as electric fields (high impedance field) and/or magnetic fields (low impedance field). Except in far field conditions, one of these will be predominant

A proper design of a VSC valve and converter layout can reduce the disturbance emissions at their source. In addition it may be necessary to use EMI filters. Emission level can be assessed by simulation and measurement in-situ.

Note. EMI (electromagnetic interference) is the degradation of the performance of an equipment, transmission channel or system caused by an electromagnetic disturbance. (IEV 161-01-06)

The IEC standard on Electromagnetic Compatibility covers emission and immunity for phenomena in the 0 to 400 GHz frequency range. This range is split into several frequency bands, according to measurement techniques.

Phenomena such as flicker, harmonics (subharmonics and interharmonics), or emission at higher frequencies (in the range of 0 Hz to 9 kHz) are within the scope of TC77A (Technical Committee 77A) of the IEC. Relevant guides also exist for medium- and high-voltage networks for distorting load [10-5] and fluctuating loads [10-6]. Emission aspects at frequencies above 9 kHz are within the scope of CISPR (Comité International Spécial Perturbation Radioélectriques – International Special Committee on Radio Interference) from IEC. Traditionally, four frequency bands are considered: 9 kHz to 150 kHz, 150 kHz to 30 MHz, 30 MHz to 1 GHz, and above 1 GHz. The two lowest frequency bands mainly relate to conducted emissions for which the disturbance voltage is measured. The highest bands relate to radiated emissions. Frequencies above 1 GHz are usually not relevant. Special attention must be paid in restricted areas such as airports and hospitals. The most relevant publications from CISPR relate to method of measurement (series CISPR16 [10-7]), and to emission (e.g., CISPR18 [10-8], which includes the corona effect, and CISPR11 [10-9], which sets out emission limits of ISM and covers measurement in-situ).

A CENELEC guide prEN50217 [10-10] (under vote procedure at the end of 2004) deals with in-situ measurements in response to complaints.

10.6 REFERENCES

- [10-1] CIGRÉ WG14.26, “HVDC Stations audible noise.” June 2001.
- [10-2] *Method for rating industrial noise affecting mixed residential and industrial areas.* British Standard BS4142, September 1997.
- [10-3] Norwegian national guidelines for restriction of industrial noise SFT: TA-506.
- [10-4] *Electromagnetic compatibility (EMC) - Part 2: Environment - Section 1: Description of the environment - Electromagnetic environment for low-frequency conducted disturbances and signalling in public power supply systems.* IEC Standard 61000-2-1:1990.

- [10-5] *Electromagnetic compatibility (EMC) - Part 3: Limits - Section 6: Assessment of emission limits for distorting loads in MV and HV power systems.* IEC Technical Report 61000-3-6:1996.
- [10-6] *Electromagnetic compatibility (EMC) - Part 3: Limits - Section 7: Assessment of emission limits for fluctuating loads in MV and HV power systems.* IEC Standard 61000-3-7:1996.
- [10-7] "Specification for radio disturbance and immunity measuring apparatus and methods." CISPR16 series, November 2003.
- [10-8] "Radio interference characteristics of overhead power lines and high-voltage equipment." CISPR18 series, 1982.
- [10-9] "Industrial, scientific and medical (ISM) radio-frequency equipment - Electromagnetic disturbance characteristics - Limits and methods of measurement." CISPR11 series, March 2003.
- [10-10] *Guide for in situ measurements. In situ measurements of disturbance emission.* European Standard prEN 50217. (This guide describes analysis methods of disturbance emission to be applied in-situ for identification of the disturbance source and resolution of complaint. Where applicable, the methods rely on already published documents either in CENELEC or in IEC. It is not intended to be used for type testing or any kind of conformity assessment.)
- [10-11] *Electromagnetic compatibility (EMC) - Part 4-7: Testing and measurement techniques - General guide on harmonics and interharmonics measurements and instrumentation, for power supply systems and equipment connected thereto.* IEC Standard 61000-4-7:2002, August 2002.

11. APPLICATION STUDIES

11.1 INTRODUCTION

This chapter discusses the studies performed as part of planning and implementation of a VSC Transmission scheme. The discussion is from the standpoint of a party acting as a client to a scheme supplier. Usually this means a grid company, but different cases may exist, e.g., power producers and/or investors may have a crucial role in a VSC Transmission project. In any case, the internal dimensioning studies of the VSC scheme are done by the scheme suppliers and are not discussed in this chapter.

The studies needed may vary substantially in accordance with different project circumstances. In some cases, VSC Transmission may clearly provide the best possible technical solution for a certain transmission need. This can be due to the ac system properties, e.g., low short-circuit levels or voltage stability problems after certain contingencies. In addition, VSC may prove to be competitive due to the possibility of using cost-effective underground cables, which produce a smaller environmental impact and require less implementation time compared with overhead ac transmission. In any case, it is usually worthwhile to look at all possible solutions before making the final decision.

The emphasis in this chapter is on the technical ac system studies needed to evaluate and specify the VSC Transmission alternative. In addition, some economical and environmental factors that must be taken into account are described and examples given of studies required in the implementation phase of the VSC scheme. The studies are divided into three main groups: feasibility studies, specification studies, and implementation studies. Figure 11.1 gives a typical flow chart of the studies needed. The sequence of these studies is usually iterative in nature.

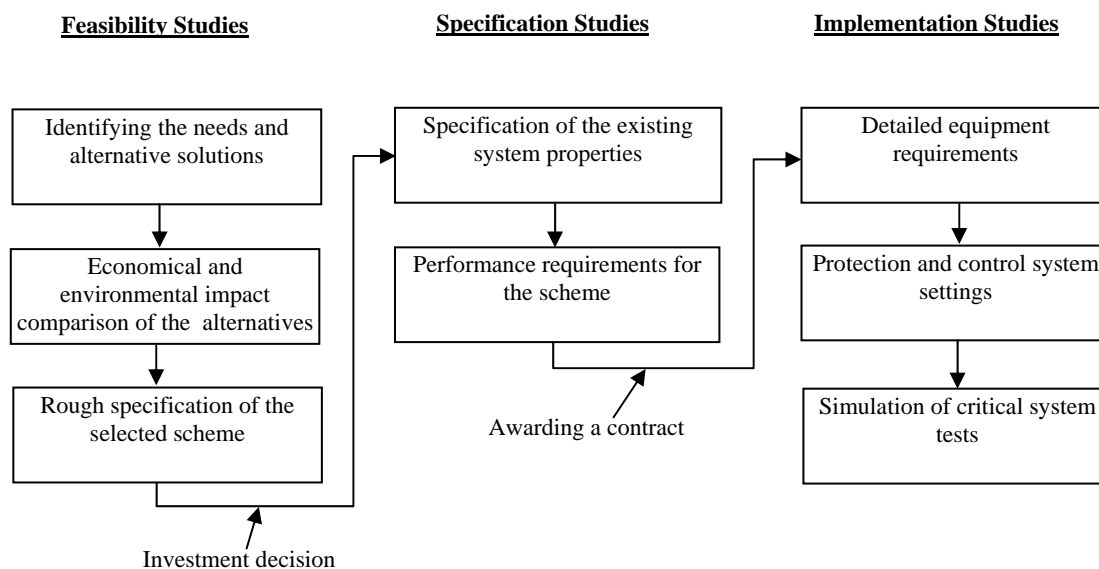

Figure 11.1: A typical flow chart of the application studies

The chapter also includes a brief description on the modelling of the VSC Transmission system. The intention is to minimise the amount of studies to be performed and to use as simple models as possible. This is because the user of the technology may wish to consider the VSC Transmission system as a "black box" giving the required amount of transmission capacity. However, the excellent technical characteristics and fast controllability of a VSC scheme make it possible to utilise it not only for basic power transmission but also to improve the performance of the ac system. Typically, the power transmission or voltage support capacity of the VSC scheme is quite low compared to the feeding ac system. However, the receiving end can also be a small isolated ac system. In any case, the studies

needed to determine the exact characteristics of the scheme required for such applications usually involve detailed modelling. These studies have to be refined during the implementation phase in close cooperation with the scheme supplier.

11.2 FEASIBILITY STUDIES

The purpose of feasibility studies is to determine whether VSC Transmission is an economically and technically suitable solution to a certain transmission need. The economic justification of a transmission scheme or interconnect is normally the first issue to be evaluated and is usually done by the party planning to invest in the scheme. The justification may be quite easily calculated in cases where an isolated area will be fed with the transmission link. The alternative cost would usually be that of increasing the local power production capacity. In instances where the transmission link will interconnect larger ac systems, the transmission needs and subsequent profitability of the scheme can be estimated using market models. These models are based on optimising the overall production costs for consecutive periods of time, taking into account the physical constraints of the transmission grid. Duration curves can estimate the electrical power transmitted through a particular interconnection, and the income and/or savings achieved by the proposed transmission capacity can be calculated. In addition to these energy balance studies, some basic technical studies are needed to evaluate the capital equipment costs and cost of losses of the transmission scheme. Since VSC technology may not be the only transmission option, the capital costs, power losses and monetary benefits of each technology must be carefully considered. (See also Chapter 13, Life Cycle Cost).

Steady-state load flows are usually quite adequate for technical feasibility studies involving controllable equipment [11-8]. A load flow study gives the busbar voltages, the active and reactive power flows, power losses, and compensation requirements for a given situation. Load flows should be calculated with different VSC Transmission levels (both P and Q) in various ac grid operating situations. This means different transfer, generation and loading patterns, as well as outage contingencies. Future requirements should also be studied with likely cases.

In some instances stability studies may have to be performed as part of the feasibility studies. These could be done to confirm the results of the load flow studies or to determine the suitability of VSC technology in a stability constrained case. However, these studies can be quite time consuming, since in some cases the user may have to create his own VSC stability models.

One factor to be remembered is that a dc connection does not typically increase the ac system short-circuit current as much as would an ac connection. Depending on the control strategy, a small increase may result, but the connection can also be blocked during ac faults. In comparison, an ac option results in an increase in short-circuit currents which may require the reinforcing of the ac system. If such results are anticipated, some short-circuit studies may need to be conducted as a part of the feasibility studies (see Section 11.3.1 and [11-9]).

11.2.1 Economic Justification of a VSC Scheme

A new HVDC transmission link (either VSC or LCC) may be economically justified for one or more of the following reasons (this list is not exhaustive and there could be additional factors which should be looked at in specific cases):

- If the link will be feeding an isolated load growth area, it may be economically justified by avoiding the cost of installing more power generation capacity. In this case the link would usually be owned by the local power producer, thus making the comparison quite straightforward.
- If the link will be of the interconnector type and located inside an open market area, no transmission tariffs will usually be applied to the power and energy flowing through the link. In this case the link will probably be owned and operated by a grid company whose congestion management principles (e.g., market splitting, counter trade or capacity auctioning) are critical. The link may be economically justified by capacity fee income, counter trade savings or market benefits.

- If the link will interconnect two separate market areas, it might also be owned by an investor or power producer. In this case, the income results either from a transmission tariff applied to the link or from the electricity price difference between the termination points of the link.
- Often a new transmission link reduces power losses in the grid. If the link is owned by a grid company, this results in direct loss purchase savings. However, it must be borne in mind that significant power losses may arise in the VSC scheme itself.
- An HVDC scheme does not (or in case of VSC, need not) increase short-circuit currents which may prevent or reduce additional investments needed in the ac grid.

In addition, VSC Transmission link may have advantages such as:

- The VSC can support the ac system by rapidly changing its active or reactive power within its MVA limits. A change in the active power of the link will naturally have an effect on both termination points, but the reactive powers at the ac terminals are independent. If a grid company owns the link, this may result in savings in purchase cost for ancillary services or for the maintenance of reserve power capacity. In other cases, the link owner can avoid installing new active/reactive power reserves or get income from selling ancillary services, such as frequency or voltage control, system damping, emergency power, or system black start capability [11-3]. As a rule, the economical value of system support by the VSC Transmission tends to get bigger as the connected ac system gets smaller.
- Compared with other alternatives, the implementation time of the VSC scheme is typically quite short. This is due to the lower environmental impact, to the modular structure, and to the possibility of using polymeric cables for dc transmission. The short implementation time usually increases the economic benefits of the VSC scheme compared to the other alternatives.
- Due to the precise control of active and reactive power of the VSC scheme, it is better able to prevent congestion in power flow corridors. This controllability also provides benefits concerning system security and/or loss reduction.

11.2.2 Comparing Alternative Termination Points for the VSC Scheme

If a VSC Transmission scheme is found to be economically attractive, the focus will shift to more technical studies. The following studies should be made when choosing the termination points (many of these studies are usually performed by the grid company):

- Calculating the ac power losses in different situations. In some cases one may end up utilising the VSC scheme for loss optimisation. This can be the case when there are ac connections parallel to the controllable VSC scheme. Optimisation studies may also be performed with an optimal power flow (OPF) program.
- Investigating whether any ac voltage profile violations may be caused in normal network operating conditions. In case of problems, it should first be determined if they can be overcome by changing the reactive power of the VSC scheme and utilising its voltage control capabilities. In the end, it may be necessary to specify the maximum allowed reactive power to be fed into or taken from the ac system. In case the violations happen farther away from the VSC scheme, the studies will give the locations and ratings of the additional reactive power compensation units needed in the ac grid. Selecting the optimal reactive power compensation strategy may require utilising an OPF program.
- Investigating if there are any critical contingencies that could lead to overloading and/or undervoltages. These may result in the setting of transmission capacity limits for the ac system or operating limits for the VSC scheme, i.e., in some operating situations the active (or reactive) power of the scheme may need to be restricted. The active power of the VSC scheme may also be altered within the thermal time constants of the ac power lines as a system protection scheme. Some problems may also be avoided by controlling the reactive power of the scheme. However, in case the load flow problems cannot be avoided by technical solutions concerning the VSC scheme itself, the studies specify the ac reinforcements required to cope with the critical contingencies. Stability studies may be needed for certain contingencies or to confirm the results of the load flow analysis.

- Determining if there are special voltage quality or control requirements for any of the alternative termination points. These requirements may be caused by such things as sensitive loads, nearby turbo generators, or inadequate ac voltage stiffness.
- Taking into account the environmental and economic aspects. Even though the footprint of a VSC substation is relatively small and polymeric underground/undersea cables may be used for transmission, there may be some restrictions affecting the selection of the termination points. In some cases, there may also be economic factors influencing the choice of location, e.g., input/output tariffs could vary depending on the termination point.

11.2.3 Comparing the Selected Scheme with Alternative Solutions

It may be that VSC Transmission is the most obvious technical solution for a given problem, such as feeding a distant passive load [11-4]. However, in many cases an LCC HVDC or even an ac connection can also be evaluated as an alternative [11-5]. Capacitor commutated converter (CCC) HVDC can also be worth studying in instances where the short-circuit levels are low and/or where there may be voltage violations after certain ac contingencies. In the case of feeding a distant isolated system, there is also the alternative of using synchronous compensators to support an LCC HVDC scheme or of increasing the local power generation. The following comparisons are usually needed between the alternatives:

- The price estimates and power losses of the alternatives
- The ac reinforcements required for each alternative
- The technical benefits of the alternatives (e.g., voltage quality, fault currents, overload capacity) and possible economic benefits originating from ancillary services
- The power supply reliability level achieved with the alternatives
- The operation and maintenance costs of the alternatives
- The time frame for permitting and for implementing the project alternatives
- The environmental effects of the alternatives, including space and weight requirements

Each of these issues will normally result in an equivalent investment cost for each alternative. An outline specification will be needed in order to evaluate the capital equipment costs and cost of losses for the VSC scheme. This specification should include the transmitted power, reactive power capability, dc voltage (or distance and terrain), characteristics of the ac connection point and networks at either end, control and harmonic requirements, and availability requirements. These requirements may in some cases affect the pole topology (see Chapter 4, VSC Transmission Topologies), which will in turn affect the costs.

11.2.4 Preparing an Outline Specification for the VSC Transmission Project

If VSC Transmission is found to be technically and economically feasible, the total costs of the scheme will have to be defined more closely in order to make the investment decision possible. To better define the cost, a project description and an outline specification of the VSC scheme must be prepared. These will typically contain the following (see also Appendix B, “Functional Specification for a VSC Transmission System”):

- Termination points and connection arrangements
- Possible ac grid reinforcements and compensation requirements
- Possible ac power transfer constraints
- List of contingencies and initial conditions for additional studies
- Preliminary ratings and desired control characteristics for the VSC scheme
- Active and reactive power rating and overloading capability
- Environmental requirements that may affect the technical solution

- Reactive power control capabilities or limits on reactive power to be fed or taken during normal operation (in case the scheme will not be utilised for voltage control)
- Identification of special control needs, e.g., to enable ancillary services, such as voltage control, black-start capability, active power modulation, frequency control, and subsynchronous resonance control (see Section 11.4)
- Grid codes to be satisfied and/or specific limits on such things as harmonics, RFI, etc.

11.3 SPECIFICATION STUDIES

Specification studies are usually performed after an investment decision is made. They are needed to prepare the detailed performance specifications for the tendering process (see also Appendix B). As a part of this process, ac system data is prepared for the equipment suppliers to enable them to design the VSC Transmission scheme.

First of all, environmental constraints have to be specified. These include, for example, minimum and maximum temperatures, area requirements, the availability of water for cooling, audible noise constraints, degree of pollution, etc. These factors may have a strong influence on the technical solutions required.

Load flow analysis is, once again, the basic tool for the technical studies. Other steady-state calculations that may be required are short-circuit studies and harmonic studies. First, the pre-existing levels of short-circuit currents and harmonics must be defined so that the requirements to be specified to the manufacturer can be evaluated. These studies also define the properties of the ac system at the connection point, which will be used by the supplier in designing the VSC scheme.

In the specification stage, dynamic studies are also needed. These can be divided into stability studies of the electromechanical system and transient studies of the electromagnetic system. Dynamic studies may be needed especially at minimum ac system strength and maximum ac transfers. The purpose of these studies is to simulate the behaviour of the ac/dc system as a function of time, and search for instabilities, overvoltages, and overcurrents. The modelling requirements sharply increase as the time scale of the studies is reduced and as more details of the dynamic behaviour of converter units and lines are taken into account.

11.3.1 Specifying the Performance Requirements for the VSC Scheme

Short-circuit studies are needed for the following purposes:

- To calculate the needed dimensioning values for the VSC scheme ac side equipment. Usually the maximum fault current levels are of interest.
- For protection coordination studies. Both maximum and minimum fault current levels are of interest. Usually the VSC scheme may contribute some short-circuit current. The amount of contribution depends on control modes, operation points and control strategies [11-9]. If the scheme feeds a passive load, it should be verified that the fault currents are big enough for the existing protection scheme (designed for ac infeed). Protection issues are discussed in more detail in Chapter 8, Fault Performance and Protection Requirements.
- The neutral earthing arrangement of interface transformers and filter branches should be designed so that they do not have a large effect on the ac earth fault currents in the vicinity of the VSC scheme.

Harmonic studies are needed for the following purposes (some of these studies may be performed in the implementation phase, see Section 11.4):

- Determining the harmonic impedances and background harmonics of the feeding ac grid at the point of connection. The impedance should be calculated for different ac system conditions, such as during contingencies and for different switching states of nearby voltage controlling

shunts (possible resonance conditions). The negative sequence content of the ac voltage should also be determined.

- Studying the harmonic interaction of the VSC scheme with the power system.
- Determining acceptable voltage and current distortions and telephone interference factors. This information is used to specify harmonic injection limits for voltage and current.

Stability studies are needed especially for identifying the required VSC control modes, control parameters and control range limits:

- In case of transient instability or insufficient system damping after critical contingencies, there may be a need in certain operational situations to set operating limits for the VSC scheme or on ac system transmission capacity. AC network reinforcements may also be required to improve damping.
- Special system protection schemes or control strategies may also result from these studies. Some problems may be avoided by modulating the power of the VSC scheme, as for damping purposes or frequency modulation. These are of special importance where parallel ac and dc connections are close to each other, or where the VSC scheme is feeding an isolated ac system.
- Strategies for reactive power or voltage control of the VSC scheme can be determined based on stability studies. These studies give the required amount of reactive power, or limit the maximum amount, to be fed or taken in different situations. When designing the control strategy, the priority between active and reactive power controls must be carefully considered.
- In some cases an eigenvalue analysis program may also be needed to check the performance of and interaction between different control systems within the ac system. Eigenvalue analysis is particularly useful in performing a screening prior to time simulations or in determining the cause of instability. The eigenvalue analysis program employs numerical linearisation of the full power system model and is usually a supplement to a stability program that utilises the same dynamic models.

Transient studies are normally needed for the following purposes:

- Evaluation of electrical stresses caused by ac system temporary and transient overvoltages on the VSC scheme
- Requirements for voltage control and protection coordination
- Requirements for internal fault clearing time of the VSC scheme
- Investigating the possibilities for utilising the scheme to mitigate power quality problems, e.g., for flicker reduction

11.3.2 AC System Data for the Design of the VSC Scheme

As a minimum, the following ac system data is required for the basic design of a VSC Transmission scheme. This data should be provided as a part of the technical specification (see also Appendix B). In case these are not directly available, some ac system studies and/or measurements may be needed.

- Range of ac voltage and frequency during normal operation and extreme conditions (also simultaneous requirements), negative sequence content of ac voltage
- Maximum allowable voltage step in the connection point during scheme energisation (depends on the ac short-circuit level)
- AC system earthing principle and earth fault factor
- Short circuit and earth fault current levels (minimum and maximum), X/R-ratio of the ac-system
- System equivalent for normal and for weakened ac system conditions

- Harmonic impedance ranges and existing background harmonics of the ac system at both connection points, criteria to be utilised for harmonic performance acceptance
- AC fault clearing times and reclosing strategies, typical amount and depth of voltage dips in the ac connection point
- Insulation levels of the ac system
- Allowed rate of change and maximum change of active power of the VSC scheme
- Reactive power limits for the VSC scheme, if any

11.4 IMPLEMENTATION STUDIES

Implementation studies are usually performed after award of a contract. Their purpose is to evaluate control and operating strategies and to identify all the operational constraints and operating requirements for the VSC scheme [11-6]. The grid company may also want to check if the envisioned ac system requirements will be met. As these studies require a detailed model of both the actual scheme and the ac system, they are usually made in close cooperation between the client and the supplier. The amount of implementation studies needed depends largely on the project. These studies are usually very similar to those for an LCC HVDC scheme.

Examples of implementation studies are:

- Detailed requirements and settings for voltage control and protection coordination, especially non-linear control design and validation. Interaction between different control systems and with other controlled components in the ac system (e.g., other HVDCs nearby).
- Specifying the internal protection functions and insulation coordination of the VSC scheme.
- Investigation of harmonic interaction.
- Finding out if there can be a risk of subsynchronous resonance (SSR) in one or more connected ac networks. This concerns the critical torsional frequencies of large turbo generators in the close vicinity of the VSC Transmission system [11-2]. In this case a quite detailed model of each turbo-generator is also needed. As a solution, the control should be designed so that it does not contribute to the critical frequencies. Sometimes generators may also be equipped with SSR protection where information on the mechanical parameters of the shaft system is unavailable, unreliable or insufficient.
- Calculating some of the most critical control and protection system tests in advance. Finding out what kind of tests should be performed.

These detailed studies are usually made with digital electromagnetic transient simulators or with transient network analysers (TNA) of analog or hybrid type. The digital simulators can be off-line programs such as PSCAD/EMTDC or EMTP, or real-time simulators such as RTDS or ARENE. The model of the VSC scheme is usually tailored to each study in question. In case of real-time simulators, it is usually possible to couple actual VSC control and protection equipment to the simulator in order to study their behaviour under different operating conditions. In addition to actual studies, most of the simulators can also be utilised for personnel training.

11.5 MODELLING OF THE VSC SCHEME

Quite simple models of the VSC Transmission system are usually adequate for feasibility studies (usually load flow studies). Depending on the purpose of the study, the link is assumed to provide constant active power, reactive power, voltage or current at the ac system connection point and is modelled with algebraic equations. However, more detailed models may be required already at this stage if the link is economically attractive because of its ability to improve the dynamic performance of the ac system. These models usually provide some kind of approximation of the action of the main control loops. Dynamic studies needed at the specification and implementation phase require more detailed representation of the control constraints and the internal dynamic behaviour of converter units and lines. Electromechanical stability studies require rms value models or linearised eigenvalue

models, while electromagnetic transient studies require instantaneous value models. Table 11.2 illustrates the various levels of modelling required for different studies.

Table 11.1: Levels of modelling required for different types and stages of studies

Level of Modelling	Type of Study	Stage of Study
Constant P, Q, U or I	Basic load flow, short circuit and harmonic studies	Feasibility/Specification
Simple P, Q and U control	Contingency load flow studies	Feasibility/Specification
Outer control loops with constraints	Electromechanical stability studies	Specification
Representation of internal dynamics of VSC and dc side	Electromagnetic transient studies	Specification/Implementation

11.5.1 Load Flow Modelling Requirements

The steady state modelling of the VSC scheme does not necessarily require any specific knowledge of the VSC technology. A PU-bus (i.e., generator bus) or a PQ-bus (i.e., load bus) model is usually quite adequate in the feasibility study phase.

The dc control strategy usually means that one converter controls the dc side voltage and the other controls the active power. In addition, the ac voltage can be controlled freely within certain limits on both termination points. This means that the VSC scheme appears usually as a generator or machine at the ac terminals. The machine MVA base is set to match the MVA rating of the VSCs. The active power output of the generator bus is positive on the inverter side and negative on the rectifier side. The active power losses in the VSC Transmission system can be taken into account by setting a corresponding difference between the negative and the positive output. If the voltage control properties of the VSC are not utilised but the reactive power is kept constant, the scheme appears as a positive and a negative load bus at the respective ends. Actually, in case there are no parallel ac ties to the VSC scheme, only one end of the scheme has to be represented in the ac network studies. Also in this case, power losses must be taken into account when setting the output power.

In case the active and reactive power performance is only given for the converter units, the ac side phase reactor, interface transformer (if used) and ac filters should also be modelled. The reactor and/or the transformer can be modelled with normal branch models. AC filters can be modelled as fixed capacitive shunts at the ac bus to which the VSC is connected [11-7].

VSC Transmission models are becoming available in power flow programs. These models take into account the physical constraints of the VSC system by placing a set of boundary conditions on the ac buses where it is connected. The models also include a simple power, var and voltage control. A VSC Transmission system can, of course, also be approximated by using a basic dc transmission model with STATCOM or SVC models at each terminating ac bus.

11.5.2 Short-Circuit and Harmonics Modelling Requirements

The modelling of the VSC Transmission scheme is usually very simple in short-circuit studies. The scheme appears as a constant current source according to its current capacity and control strategy (it may in some cases be entirely blocked during the fault). Fault simulations may also be performed using an electromagnetic transient program, where a more accurate model of the VSC scheme is used (see Section 11.5.4). These simulations also give short-circuit currents on the dc side.

In harmonic studies, the VSC scheme itself is usually modelled only as a source of harmonic voltages that is connected to the ac system via impedance. However, the filtering equipment of the scheme must

be accurately modelled. The modelling of the ac system is in many parts the same as in load flow and short-circuit studies (e.g., transformers, generators and shunt devices). The load flow data of the system can thereby be utilised as a basis for the harmonic model. However, the model usually has to be more specific in case of transmission lines (three-phase modelling) and nearby loads [11-1].

Harmonic studies may also be made in time domain if, for example, control interaction (e.g., SSR) or inrush currents are studied. In this case, the simulation model is very detailed and includes also the VSC controls. The tools for these time domain studies can be analog, digital or hybrid ones (see Section 11.4). Usually, the same tools can be used for electromagnetic transient studies.

11.5.3 Electromechanical Stability Modelling Requirements

The purpose of the electromechanical stability studies is to evaluate the interaction between the VSC and ac transmission systems. Balanced, positive sequence system behaviour is represented as a set of differential and algebraic equations. The results of a load flow study are used as initial conditions for the simulation. The bandwidth of stability studies is typically between 0-10 Hz. The dynamic behaviour of the VSC scheme is dominated by its controls. However, because the bandwidth of the controls is far greater than in the dynamic simulation in general, it is not practical or necessary to represent the detailed dynamics of the VSC controls. In many cases it may be enough to model the system level control loops, such as dc voltage control, active power control, ac voltage control and reactive power control. The first and simplified approach is to use an LCC HVDC stability model with STATCOM or SVC models at each ac termination point.

In addition to the outer control loops, the VSC stability models should include control constraints which temporarily override the normal operating setpoints in case of disturbances. These include, for example, current output limitation of the converters and converter blocking. Additionally, supplementary modulation controls or single control actions such as power ramping may be modelled [11-7]. Non linearities and smaller time constants are usually neglected and pseudo steady-state dynamic models are used where the simulation is based on steady-state relationships between the electrical variables. Thus, the models do not represent the internal dynamic behaviour of converter units and lines or the internal protection functions of the converters, but give an approximate representation of the dc characteristics. The internal time delays of the VSC scheme are in this case mainly associated with the delays in changing the dc current. No direct communication between the VSC terminals is required in practice. However, in order to take into account the effect of the VSC current limitations on the power reference, which is not properly represented in the simplified model, an artificial "Central Power Controller" may be necessary [11-7].

11.5.4 Electromagnetic Transient Modelling Requirements

The electromagnetic transient model of the VSC scheme is usually tailor-made and aims at representing the actual physical operation of the VSC scheme in the time domain extending from microseconds to seconds. A three-phase model is often required. The available programs normally allow users to define their own models, but some ready-to-use basic block models are also available. Three-phase modelling and the time range of the studies require quite detailed models of other ac system components as well—for example, transformer saturation has to be taken into account. Unlike the load flow and stability model representations which use fundamental frequency impedances, the ac network representation is detailed and includes the models of resistors, capacitors, inductors and distributed parameter transmission lines. If subsynchronous resonance phenomena are being studied, a detailed representation of the electrical and mechanical characteristics of generators in close proximity to the converter is also required.

This level of modelling usually depicts the controls in some detail and includes models of the synchronization and firing system. For network impact studies, a simple on/off representation of the switching device, without the snubber circuits, is often adequate. There may, however, be many different levels of modelling depending on the phenomena being investigated, e.g.:

- For harmonic interaction studies, the valve firing circuits are represented in detail, and the high frequency elements, such as the switching frequency filters, are also represented.
- For system transient studies and controller response analysis, the high frequency elements may be omitted and a shunt filter used on the ac side to prevent the simulated converter harmonics from entering the network. Sometimes the switching frequency is reduced in order to permit the use of a larger simulation time-step. Often, the PWM converter is represented by a simplified model in which the ac voltage is a scaled product of the modulating wave (derived from the modulation index) and the VSC dc capacitor voltage. Likewise the dc side current is modelled as a scaled sum of the ac currents.

11.6 REFERENCES

- [11-1] Arrillaga, J., Arnold, C.P., *Computer Analysis of Power Systems*. John Wiley & Sons, Hoboken, NJ, 1991.
- [11-2] CIGRÉ WG 14.20, *Economic Assessment of HVDC Links*. CIGRE Technical Brochure No. 186, June 2001.
- [11-3] Ancillary Service Review: Report to NECA. October 1999. (<http://www.nemmco.com.au>)
- [11-4] Axelsson, U., Holm, A., Liljegren, C., Eriksson, K., Weimers, L., "Gotland HVDC light transmission - world's first commercial small scale DC transmission." CIRED Conference, May 1999.
- [11-5] Asplund, G., Eriksson, K., Jiang, H., Lindberg, J., Pålsson, R., Svensson, K., "DC Transmission Based on Voltage Source Converters." CIGRE SC 14 Colloquium, No. 14-302, 1998.
- [11-6] TransÉnergie U.S. Ltd, "Cross Sound HVDC Cable Project, System Impact Study of New York Area" (Draft, December 2000). (<http://www.nyiso.com/services/planning.html>: Interconnection Study for the CT-LI dc Tie-Line Transmission Project - Study Documentation)
- [11-7] CIGRÉ WG 14.19: Static Synchronous Compensator (Statcom). CIGRÉ Technical Brochure No. 144, August 1999.
- [11-8] Jiang-Häfner, Y., Hyttinen, M., Pääjärvi, B., "On the Short Circuit Current Contribution of HVDC Light." IEEE/PES T&D 2002 Asia Pacific, Yokohama, Japan, October 2002.

12. TESTING AND COMMISSIONING

12.1 INTRODUCTION

This chapter provides general guidelines for testing and commissioning VSC Transmission systems. Emphasis has been put on subsystem and system tests rather than those for components. This emphasis is due partly to time constraints, but also because VSC Transmission equipment is evolving so rapidly in terms of technology, unit power size and voltage levels.

CIGRÉ WG 14.12 has produced a report on system tests for LCC HVDC transmission [12-1]. Many of the tests described in that *Electra* brochure are applicable to VSC Transmission. Reference should also be made to the work of IEEE Working Group 15 [12-2].

It is recommended that future CIGRÉ working groups be devoted specifically to developing more detailed system tests and tests for key VSC transmission equipment, such as the VSC valves, phase reactors, dc capacitors, etc. This would be similar to the process followed, for example, for LCC HVDC thyristor valves and converter transformers. In developing a full test recommendation for VSC valves, a future working group might use the methodology in IEC60700-1 as the basis for its work.

12.2 THE TESTING AND COMMISSIONING PROCESS

Testing and commissioning are part of a process that begins in the factory and ends with the handing over of the equipment for commercial operation. There are two distinct phases: factory or off-site testing, and on-site testing. Off-site testing is usually performed to prove that equipment, including the control system, meets the design criteria. Commissioning tests are performed after the equipment has been delivered to the site and installed. The tests are organised to test subsystems, systems and overall performance.

It is especially important to retain test records following the tests, since at some future time there may be a need to modify the VSC. For example, factory tests for a new or modified control system would need to verify that the test set up was able to reproduce the performance of the original equipment before starting to test any new functions. Without test records from the original commissioning tests, it would be impossible to determine if the new test setup accurately modeled the existing equipment.

The following sections cover the main topics to be considered in the development of test plans. Although test plans are usually developed by the equipment supplier, it is important that the purchaser have a comprehensive understanding of all of the tests to be conducted. Testing is important but expensive. In specifying tests, the purchaser should be certain a particular test is worth the cost. As a general rule, all parties involved in the project should be included in the tests and all responsibilities clearly defined.

Commissioning of a VSC substation is similar to that for a static var compensator or LCC HVDC system. The principal differences are in the testing of the converter valves, the dc equipment, and the different system applications. In addition, it is possible to prove subsystems prior to the power transmission tests by performing tests on each terminal of the VSC Transmission system in high-voltage open circuit ac and STATCOM modes.

Besides the various factory tests and other off-site tests, prerequisites for commissioning include the following site verifications and inspections:

- Verification and inspection during civil work
- Pre-installation verification and inspection
- Verification during installation

The on-site inspection and test activities can be broken down as follows:

- Equipment tests
- Subsystem tests
- System tests
- Trial operation
- Acceptance tests

12.3 FACTORY TESTS

12.3.1 Component Tests

These tests concern the verification of the single components, including control and protection equipment, before they are sent to site. They may be subdivided into routine tests, aimed essentially at quality control, and type tests which verify that a component has been properly designed to sustain the stresses from potential transients and service conditions. Typically, independent standards (IEC, IEEE, ANSI) are cited for type or design tests and for routine tests. Therefore, they are well defined for traditional components such as switchgear, transformers, capacitors, capacitors fuses, reactors, resistors, insulators, voltage and current transformers, surge arresters, etc.

For a VSC, reference may be made to similar standards already available. For operational tests, IEC 60146.2 (low-voltage drive VSCs) contains valuable information even for a high-voltage VSC in a power grid connection. In developing a full test recommendation for VSC valves, a future working group might use the methodology in IEC60700-1 as a basis for its work. IEC60060 can be used for test conditions and procedures, and IEC60270 for partial discharge measurements. These standards must, of course, be used with careful consideration of the actual stress the converter will experience in a VSC Transmission system. Some adaptation will likely be necessary.

12.3.2 Control System Tests

As with the controls for LCC HVDC systems, the control system for a VSC Transmission system, including hardware, software and documentation, can be tested and verified in a factory system test (FST). A real time simulator will be required that can represent power components and parts of the ac system in a sufficiently detailed way. Every effort should be made to test as complete a system as practical, including redundancy, so as to minimise work on site. Factory system testing is an extensive and thorough check of the control and protection system under normal and fault conditions, without the constraints imposed by the real system. Selected on-site system tests will repeat some of the factory system tests, but will include the actual transducers and main circuit equipment, as well as actual system conditions (as permitted within system constraints). All software and hardware functions, including redundancies, should be tested before the equipment is shipped to site for installation and commissioning.

Extensive control testing in the factory can explore many cases that are either impossible, too risky, or too expensive to do on site, and will allow overall functional performance to be verified under both normal and transient conditions. For example, simulator testing can involve multiple fault cases that would be impractical to test in the field.

Besides simulator tests identical to those for conventional HVDC, other tests should be considered that account for the additional modes of operation possible with a VSC. Each mode should be tested both in the factory and during commissioning (e.g., operation of the converter like a STATCOM, black start capabilities, and feeding a passive network). The results obtained from real time simulator tests and system studies (in particular the dynamic performances studies), are the main references used to define the commissioning plan and validate the test results in the field.

12.4 SITE TESTS (COMMISSIONING)

12.4.1 General

Site tests are conducted after the equipment has been transported to the site and installed, and are organised in a succession of phases.

The first phase is the so-called “precommissioning tests” executed on single station components in order to check their condition and functionality after transport and assembly. This phase is followed by the “subsystem tests,” which test several components working together to perform a specific function. These are followed by the “system tests,” which involve all converter stations and full power transmission. The system tests require careful coordination between all interested parties, in particular the system operators, utilities and industrial customers that could be affected by the tests.

During inspection and testing, all applicable health, safety and environmental requirements and regulations must be followed. Any deviations should be discussed and resolved at site meetings. Often there is an overlap between commissioning and installation, especially in the area of cable termination. Care must be taken when subsystems are energised and started up that personnel are notified so that no potentially hazardous conditions exist. Most utilities have extensive safety rules that protect workers from accidental electrical contact. Observation of these rules is both essential and restrictive. Testing and commissioning become much more time consuming once safety rules apply. It is efficient and important to complete all possible testing before equipment is ready to be energised; otherwise testing that does not demand energised equipment will take much longer to test because of clearances and work permits required for safety purposes.

12.4.2 Precommissioning Tests

Precommissioning consists mainly of inspection and equipment tests. Equipment tests include electrical and mechanical tests and simple functional tests confined to a single installed unit. The purpose of these tests is to check the condition of the equipment and verify proper installation. If normal auxiliary power is not yet available, equipment operational tests can be performed with portable or temporary power supplies. At this stage, settings are verified in protection and control equipment.

In those cases where disconnection and reconnection would be required for the equipment tests, precommissioning tests on main circuit equipment should be performed before the main conductors are connected. Equipment tests should be performed immediately after installation, and according to the manufacturer’s recommendations.

12.4.3 Subsystem Tests

Subsystem tests verify the proper operation of a group of interconnected or related equipment in preparation for subsequent energisation, operational testing or transmission testing. Subsystem testing should be done with as big a functional chain of equipment and controls as possible, and should check as many functions as possible.

During subsystem testing, complete control, protection and measurement functions are tested along with the associated equipment and interconnections. Subsystem tests are performed after all equipment tests in that particular subsystem have been completed.

Subsystem testing of the auxiliary power subsystem should be done as early as possible, since both ac and dc power are required for tests on other subsystems, and in some cases even for equipment tests.

Typical subsystem tests are:

- Subsystem functional testing
Subsystem functional or circuit tests check the equipment in a specific subsystem along with its associated control and measurement interconnections. This process involves checking

circuitry using the plant circuit diagram and marking each signal path as verified, and correcting errors discovered in either the connections or documentation. These tests are confined to the external circuitry, as internal connections in the control and protection system cubicles have already been checked in a similar fashion in the factory system (off-site) test of the control and protection equipment.

- Start-up of auxiliary systems

The start-up of the auxiliary systems and the demonstration of their compliance with the applicable performance requirements take place before advancing to the site system tests or high-voltage energisation phase of commissioning.

- Primary injection

The low-voltage injection test (230 V – 1 kV) of transformers, with the winding on the secondary side short-circuited, is performed to check the proper connection of differential protections.

Note: These tests can often be combined with primary injection tests. Primary injection tests, with the main ac circuit energised with low voltage at one location and a short circuit at another, are carried out to check the ratio, polarity and phasing of “secondary circuits” on current transformers and other transducers, all the way into the control and protection system.

Note: These tests can often be done simultaneously on a three-phase basis for a large portion of the station, including transformers, by energising with a low-voltage three-phase source, e.g., auxiliary power or distribution transformer bank.

- Low-voltage energisation

The feasibility of the following tests depends on the design and rating of the application. The tests should be carried out with as few modifications as possible to the hardware and software.

- Low-voltage ac energisation tests of the interface transformer and voltage transducers to check phasing of the firing control system (open circuit measurements).
- Checking of the gate signals from the valve switching control by testing the valve switching pattern compared to the reference voltage. For high-voltage valves this may be done with a dc power supply across one valve level at a time. This would typically be done for each VSC valve in the converter.
- Low-voltage ac energisation of the VSC and dc capacitor from the ac side using low ac voltage via rectification from the free-wheeling diodes in the converter to generate a dc voltage. To get sufficient voltage per valve level and keep the dc voltage low, all but one element in each valve may be shorted-out with test wires. It may be necessary to override the valve level failure detection system. This test enables functional operation of the entire converter from its valve control system. This only needs to be done with one valve level in each valve in operation, as each level will already have been checked with the low-voltage dc energisation.
- Optionally, if an adequate capacity dc power supply is available to charge the dc capacitor, the full converter can be operated to generate full or partial ac voltage.

12.4.4 System Tests

The system tests involve operating the converter(s) in conjunction with the interconnected ac transmission system. These tests should not only check for proper performance of the automatic controls during normal changes in references, set points or operating modes, but also take place, in so far as possible, under different network conditions. System tests should also include selected disturbances to verify dynamic performance and robustness. Disturbances can consist of nearby capacitor bank switching, transformer energisation, line switching, generator tripping, step responses, or even staged faults, and should cover the most critical conditions evidenced by the system studies and by simulator tests, in so far as the networks allow. Some tests with high potential impact may require special provisions to mitigate the possible adverse system impact of large reactive/active power

variations. These will require tight coordination with the Transmission System Operator (TSO)/utilities of ac networks to which the VSC Transmission system is connected.

Usually, tests with lower impact on ac networks are performed first, followed by the the more onerous ones.

It must also be emphasized that all system tests, together with the following trial operation phase, constitute an important period of training for the VSC substation operation staff.

Prerequisites for on-site system tests include not only the precommissioning and subsystem tests performed on site, but also factory tests on the actual control system conducted with a real time simulator, together with system study results (in particular the ones regarding “dynamic performance”).

System tests can be broken down as follows:

- High-voltage energisation
- Converter operational tests
- Transmission tests

12.4.4.1 High-Voltage Energisation

When all prerequisites for high-voltage energisation have been completed, operational authority is transferred to system operators to ensure that all safety rules are followed and that any system constraints are observed. Operational procedures should be formalised beforehand. High-voltage energisation is preceded by final trip tests and “dry run” tests where the operators execute the procedure without actually energising the equipment.

Energisation of ac equipment follows a step-by-step sequence for the ac buses, bays, filters and transformers. This may require temporary disconnection of some high-voltage terminations where disconnect switches are not provided. Equipment should be initially energised for several hours. Checks are made for corona and any abnormal audible noise. Phasing and phase rotation are rechecked with full voltage. During filter energisation, unbalance protections are checked and load checks are made. Visual inspections of all equipment and surge arrester counters are made before and after energisation.

Energisation of the converter and dc equipment follows that of the ac equipment. In most cases, valve cooling should be running before energising the converter. With the VSC, the connected dc side equipment (i.e., dc buswork, dc capacitors and dc transducers) is energised through the valve anti-parallel diodes when the main ac breaker is closed thereby energising the converter. During energisation, dc voltage measurements and status signals from individual semiconductor positions should be checked via the valve monitoring.

If other converters or dc cables are included in the particular application, they should be initially energised separately while isolated from the other converter(s) and interconnecting cables or buswork.

Compared to LCC HVDC systems, the VSC includes free-wheeling diodes which energise the dc system immediately when the ac is energised. Therefore, the energisation will also check the correct performance of the energisation process, including the timing of pre-insertion resistors, if any, and any other steps taken to minimise the voltage overshoot on the dc capacitor.

12.4.4.2 Converter Operational Tests

Once the converter and dc equipment have been energised and checked out, the converter can be deblocked, sending switching pulses to the valves. Initially this is performed one converter at a time, with the VSC operated in ac voltage control or reactive power control. The purpose of the converter operational tests is to check that the converter operates properly with the ac network.

Converter operational testing is the first time that all subsystems, e.g., controls, transducers, auxiliaries and main circuit equipment, are tested together

Typical tests performed during converter operation are the following:

- **Sequences.** Check that breakers, disconnects and deblock/block and trip sequences operate properly in response to manual, automatic or protective orders. Check that the initial operating condition is neutral minimising the disturbance to the network, e.g., automatic connection of filters, if any, with net zero reactive power exchange through counterbalancing VSC absorption.
- **DC voltage control.** Check that the dc voltage is controlled to its reference voltage, and that all levels of dc voltages are balanced.
- **Measurements.** Check that all controls, indications and measurements have correct polarity, phase and scaling. Take selected measurements of ac and dc harmonics and distortion. **Note:** Final measurements are usually reserved for acceptance tests.
- **Reactive power control.** Check that the reactive power control, if relevant, follows the reference at the selected ramp rate for both inductive and capacitive ranges. **Note:** Operating restrictions on ac voltage may limit the amount of reactive power that can be exchanged with the ac network.
- **AC voltage control.** Check that the voltage is controlled to the reference, if relevant, and that the reactive power is stable. Vary slope, reference, deadband and voltage control modes, as provided. Check stability with the ac network by reference step response, capacitor bank switching and/or ac line switching.
- **Load test.** Check the capability of the cooling equipment, primarily for the VSC valves. Observe the temperatures and sequencing of the cooling equipment as the load is increased. **Note:** Operating restrictions on ac voltage may limit the amount of reactive power that can be exchanged with the ac network, and special provisions must then be made to reach full output.
- **Disturbance tests.** In addition to the testing of the step responses to regulator references, the converter and its controls should be tested for various internal disturbances (e.g., auxiliary supply changeover, control system changeover, and external disturbances in the ac transmission system) to verify proper performance, stability and robustness. External disturbances can consist of switching nearby capacitor banks, transformers, transmission lines, or tripping generators.

12.4.4.3 Transmission Tests

Transmission tests involve operation of converters that work together to control the power flow. Such testing requires a very high degree of coordination with the system operator (dispatcher).

Typical tests performed during transmission testing are as follows:

- **Sequences.** Check that breakers, disconnects and deblock/block and trip sequences operate properly in response to manual, automatic or protective orders. Check that the initial operating condition is neutral, minimising the disturbance to the network, e.g., zero net reactive or active power exchange.
- **DC voltage control.** Energisation of high-voltage dc cables, bus work or lines interconnecting the converters. Repeat with the other converter connected. Depending on application and protective strategy, check that the dc voltage is controlled to a reference during power transfer and blocking/tripping of one of the other converters.
- **Power control.** Check that the power flow and power ramp rate follow the reference values. Check the power control stability by step response or system disturbance, such as line switching. Check transmission in both directions.

- **Reactive power control.** Check, if relevant, the joint operation of the reactive power control and active power control at the different converters by changing their respective references during the different operating modes. Check proper converter MVA limitations.
- **AC voltage control.** Check, if relevant, the joint operation of the ac voltage control and active power control at the different converters. Check the stability by step response in the power and voltage references, or during system disturbances such as capacitor bank or line switching.
- **Load test.** Ramp up to full power transmission or MVA converter rating for the different operating modes, as permitted by ac system and other conditions.
- **Measurements.** Take selected measurements of ac and dc harmonics, ac voltage distortion, RI and PLC interference levels. **Note:** Final measurements are usually reserved for acceptance tests.
- **Redundancy checks.** If the system is equipped with redundant control and protection systems, perform transfers from the active to standby system. Transfers between redundant auxiliary systems should also be checked during operation, e.g., auxiliary power, cooling pumps.
- **Remote control.** Test operation from remote locations. Check all remote indications and control functions. **Note:** Much of this work is done beforehand during subsystem testing, but this is the first time that remote system operators have direct control of the system. Previously, operation was from the local level with authorisation only from the system operator.
- **Disturbance tests.** In addition to testing the step responses to regulator references, the converter and its controls should be tested again for various external disturbances in the ac transmission system to verify proper performance, stability and robustness. External disturbances can consist of switching nearby capacitor banks, transformers, transmission lines, tripping generators, or even staged faults, e.g., dc or ac overhead line faults, as relevant.

12.4.5 Trial Operation

Trial operation allows the owner to operate the integrated system according to its intended purpose from the normal control location. Trial operation does not start until almost all system tests have been successfully completed. During trial operation, observation of the complete system and subsystems takes place. All alarms or abnormal conditions are dealt with as required.

12.4.6 Acceptance Tests

Acceptance tests verify the performance of the system according to the specification on a selected basis. Acceptance tests may involve measurements to verify that interference levels are within the design limits and that other fundamental performance criteria are met.

- **Heat run.** Operate at rated and overload capacity for specified periods of time in different operating modes, if applicable. Monitor temperatures and cooling systems. This test usually takes several hours due to the slow heating of the transformers.
- **Interference measurements.** Verify that harmonics on the ac and dc sides, audible noise, radio interference, PLC interference, etc., meet the performance requirements.
- **Disturbance response.** Test auxiliary supply changeover, control system changeover, line switching, shunt bank switching, generator tripping or staged faults, as necessary.

A measurement of power losses may be included in the acceptance tests. However, it should be noted that measuring power losses is somewhat imprecise, due to the inaccuracy of transducers and the fact that actual power losses will depend on operating conditions and environmental factors. Consequently, for the purpose of the power loss guarantee, power losses are usually based on calculated values and factory measurements. The power loss calculation would follow a methodology similar to that used for LCC HVDC, but must take into account the different operating stresses and the characteristics of the

VSC valves and other components. As mentioned elsewhere, it is recommended that a new working group be established to formalise the evaluation of power losses for VSC Transmission.

12.5 REFERENCES

- [12-1] Working Group 14.12, "System Tests for HVDC Installations." CIGRÉ Brochure No. 97, 1995.

13. LIFE CYCLE COST

13.1 INTRODUCTION

The selection of VSC Transmission as an alternative to LCC HVDC, ac transmission, or local generation is normally motivated by financial, technical or environmental advantages [13-1]. When evaluating different technologies, it is important to compare their life cycle costs. This chapter discusses how to determine the life cycle cost of a VSC Transmission scheme. Some of the discussion is, of course, relevant to the cost of the schemes of other technologies.

13.2 DETERMINATION OF THE PROFITABILITY OF AN INVESTMENT

Investments in systems can either be absolutely or relatively profitable. An investment is absolutely profitable when it causes a positive result in itself, whereas it is relatively profitable if it causes a better result than an alternative investment.

In order to evaluate the profitability of an investment, it is important to determine its net payments received, which is the difference between the income and expense associated with the investment. An investment is profitable if the capital value of the investment is higher than or equal to zero. The capital value is the sum of the present value of all net payments received. This chapter only discusses the determination of the present value of the expenses, which is known as the life cycle cost.

The electrical equipment procured at the lowest initial cost may not necessarily be that which also costs the least sum of money during the life cycle of the equipment. The equipment ownership cost could be quite significant. The life cycle cost analysis includes not only the original cost of the equipment, but also all the costs incurred during the life of the plant.

Life cycle analysis can be used for comparing competing projects, long range planning and budgeting, selecting among competing bidders, controlling an ongoing project, comparing logistical concepts, and deciding when to replace ageing equipment [13-1]. In this chapter, the discussion of VSC Transmission system life cycle cost is designed to enable:

- A comparison of a VSC Transmission system with other competing technologies (e.g., ac connection or LCC HVDC system, etc.)
- A comparison of the cost of a different competing VSC Transmission system solution

13.3 LIFE CYCLE COSTING

The following information is required to assess the life cycle cost of a VSC Transmission system:

- Useful operational life of the transmission system
- Interest and inflation rates
- Procurement cost of the transmission system
- Installation cost of the system
- Cost of spare parts
- Annual cost of system losses
- Cost of periodic refurbishment
- Annual operating cost of the system
- Annual maintenance cost of the system
- Annual cost of unavailability
- Salvage value, or disposal cost of the system

13.3.1 Operational Life

The technical design life of transmission systems is normally very long—30 years or more. The time period over which the investment provide the highest capital value is designated the “optimal life.” The “optimal life” will always be equal to or less than the technical design life. Some investors may require a short operation lifetime of 10 years, for example.

13.3.2 Interest and Inflation Rates—Calculation of Present Value

Life cycle costs can either be calculated as current costs or as fixed costs. When calculating present values, the present value of future costs should be calculated by using the inflation rate and the interest rate. An estimated value of the true rate can also be used.

Using:

Life of the system	=	n	years
Average interest rate per year	=	i	
Average inflation rate per year	=	j	

The present cost, C, of a regularly occurring average annual expenditure of A can be calculated as:

$$C = A \times ([(1+j)/(1+i)] + [(1+j)^2/(1+i)^2] + \dots + [(1+j)^n/(1+i)^n]) \quad \text{Equation 13.1}$$

Similarly, the present cost C of a future cost A₁, A₂, A₃ incurred in years k, m, and s, respectively, is calculated as:

$$C = A_1[(1+j)^k/(1+i)^k] + A_2[(1+j)^m/(1+i)^m] + A_3[(1+j)^s/(1+i)^s] \quad \text{Equation 13.2}$$

13.3.3 Initial Costs of the System

Initial costs should include all costs associated with procurement of the transmission system, e.g., project development, planning, engineering, environmental assessments and licensing, land procurement, foundation and building costs, equipment and cables, and any items not accounted for in the order (e.g., equipment and/or services, if any, not on the manufacturer’s invoice).

13.3.4 Cost of Spare Parts

The cost and amount of spare parts are closely related to the requirements specified for the transmission system. If a very high availability of a transmission scheme is specified, it will imply more spare parts in reserve, especially of those parts with a long repair time and, consequently, a potentially long down time. If a spare transformer is required, for example, it will have a significant influence on the cost of spare parts, as the transformer is one of the most expensive single components of a scheme.

The bidders should offer the required number of spare parts in accordance with the specified availability.

13.3.5 Annual Costs of System Losses

The total scheme losses are the sum of the transmission losses and the losses in the converter stations.

The losses can be split up into the following components:

- No-load losses
- Variable losses

No-load losses are constant losses in transformers, converter valves, auxiliary systems, and filters that occur when the equipment is energized at no load. The auxiliary systems include power supply of cooling, heating and control equipment, and can be taken as a percentage of the full load losses.

Variable losses are dependent on the operating mode. In order to evaluate the variable losses, it is necessary to define the expected operating modes (see Chapter 2.3 for modes of operation) for the scheme. The investor should define the different operating modes for the system, e.g., full active load with zero reactive power, half active load with half reactive generation (or absorption), zero active power and full reactive power generation (or absorption). The bidders should provide the power loss for each condition. The average power loss can then be determined by assigning a weighting factor to each condition, dependant on the amount of time expected for each, and adding the losses multiplied by the relevant factors.

A VSC Transmission converter has relatively higher losses than an LCC HVDC converter (See Chapter 5.4.1). The VSC's power losses depend on the characteristics of the semiconductor device and the switching frequency, as well as on the real and reactive power. The load losses increase with the switching frequency. The costs of these losses can add up to large amounts over the lifetime of the VSC system.

The load losses can be reduced by design, but this generally results in higher initial capital cost. The life cycle cost can be optimised by selecting a design that minimizes the sum of the capital cost and the life cycle cost of the losses.

13.3.6 Cost of Periodic Refurbishment

The cost of periodic refurbishment includes:

- Internal and external labour costs
- Cost of expert assistance
- Material costs
- Cost of supplies

13.3.7 Annual Operating Costs of the System

The operating costs of the system include:

- Labour cost
- Cost of material
- Cost of supplies (auxiliary power supply)
- Insurance

13.3.8 Annual Maintenance Costs of the System

The estimation of the annual maintenance cost must be made in accordance with maintenance guidelines and instructions for each type of equipment. The cost includes materials and the hourly rates of maintenance technicians and expert personnel.

13.3.9 Annual Cost of Unavailability

Unavailability can either be forced or scheduled:

- Forced energy unavailability (FEU) is the amount of energy that could not be transmitted over the dc system due to forced outages.

- Scheduled energy unavailability (SEU) is the amount of energy that could not be transmitted due to scheduled outages.

The unavailability of power can have a great impact on society. FEU has a greater impact than SEU. It is difficult to estimate the cost of non-delivered power and energy due to unavailability, since the inconvenience and financial impact vary with the customer. Reference [13-4] may be used as guide line for determining the cost of unavailability.

The cost of unavailability should be calculated according to the investor's specifications.

13.3.10 Salvage Value or Disposal Costs of VSC Transmission Systems

At the end of its operational life, the system will have a salvage value and some disposal costs.

13.3.10.1 Salvage Value

If the operational life of the system is shorter than the technical design life, the system will likely have some salvage value. In cases where the operational life of the system is closer to the technical design life, the salvage value may be zero.

The present value of the salvage cost should be treated as a credit in calculating the life cycle cost.

13.3.10.2 Disposal Cost

The disposal cost is the expense associated with disposing of the assets, including any environmental cleanup that may be required.

The present value of the disposal cost should be added as a cost in calculating the life cycle cost.

In order to estimate the disposal cost of a VSC Transmission system, the raw materials used for the various equipment must be specified.

The raw material can be classified in three categories:

- Volume waste
- Dangerous waste
- Recycling waste

Volume waste can be concrete, bricks and other types of remaining waste that can be disposed of on a normal dump. In instances where the concrete can be crunched and reused as filling material, the deposit costs will be reduced.

Dangerous waste has to be disposed of at special sites or be burned in incinerator plants. The cost of such disposal can be significant.

Typical recycling waste is metal, such as copper, aluminum and iron.

13.4 BENEFITS OF CONTROLLABILITY

A VSC can be designed with one or more of the following control features:

- Real power control
- AC voltage control/Reactive power control

- Power reversal
- Damping of oscillations

When comparing a VSC Transmission system with a comparable ac system, the net benefit (additional cost of the control features less the benefits of the control features) of these controls must be credited to the life cycle cost of the VSC Transmission system.

13.5 REFERENCES

- [13-1] Dhillon, B.S., *Life Cycle Costing*. Gordon and Breach Science Publishers, New York, 1989.
- [13-2] CIGRÉ 14.20, "Economic Assessment of HVDC Links," CIGRÉ Brochure No. 186, 2001.
- [13-3] CIGRÉ 14.04, "A Survey of the Reliability of HVDC Systems Throughout the World during 2001-2002." CIGRÉ Paper B4-201, 2004.
- [13-4] CIGRÉ Task Force 38.06.01, "Methods to Consider Interruption Costs in Power Systems Analysis." CIGRÉ Brochure No. 191, 2000.

14. COMPARISON OF LINE COMMUTATED CONVERTER AND VSC

14.1 INTRODUCTION

This chapter presents a brief comparison between LCC HVDC transmission and VSC Transmission.

14.2 DIFFERENCES RESULTING FROM THE COMMUTATION PRINCIPLE

This section discusses the differences between LCC HVDC and VSC Transmission technologies that are defined by the types of switches each uses: LCC HVDC uses thyristors, which are closed by a gate signal and open naturally when their current reaches zero and tries to reverse; while a VSC uses switches with a controlled turn-on and turn-off capability that enables self-commutation.

14.2.1 Dependence on an AC Voltage Source

An LCC HVDC scheme depends on an ac voltage source in the ac system for the commutation process, i.e., the current in the converter valves being brought to zero as another valve takes over. If there is no generator in the ac network, a synchronous compensator or a STATCOM can be used to provide the necessary voltage source.

The self-commutated VSC does not require a voltage source in the ac system, since the commutation can be forced by turning off converter valves, irrespective of the state of the ac system or the current carried at the time. This is one of the fundamental differences between LCC HVDC and VSC Transmission, and some of the other differences mentioned later result from this.

14.2.2 Reactive Power Consumption or Generation

The LCC HVDC converter consumes reactive power because the commutation circuit is dominated by the leakage reactance of the converter transformer. Therefore, the current phase angle inherently lags the voltage phase angle, even if the control delay angle is selected as 0° , which is the theoretical minimum value needed to turn on a thyristor valve. In practice, the thyristors used in the LCC operate at higher minimum angles for security reasons, and only by delaying the gate pulses further can they be used to control the converter current. Therefore, the LCC current is always delayed compared to the voltage, which corresponds to reactive power consumption. For the inverter operation, due to the turn-off time of the thyristor, a minimum extinction angle of around 15° has to be taken to prevent a commutation failure. This factor also increases the reactive power consumption in the LCC. The amount of the reactive power consumption is about 50% to 60% of the active power in normal operation of LCC HVDC.

As the reactive power absorption of the LCC HVDC varies with load, it is normal to provide a number of switchable filter and shunt capacitor banks. These banks are switched by means of circuit breakers, such that their generation of reactive power matches the LCC HVDC reactive power absorption. A few LCC schemes use a different converter topology, in which a capacitor is inserted in series with the converter transformer to provide reactive power compensation. This technology, which is called Capacitor Commutated Converter HVDC (CCC HVDC), reduces reactive power absorption.

The VSC can be controlled to generate or absorb reactive power, as required. Moreover, the control of reactive power is independent from the control of active power, subject to overall design limits. Very rapid and versatile reactive power control is available in the VSC application, which can bring significant benefits to the ac network.

14.2.3 Short-Circuit Level Requirement for Stable Operation

The short-circuit ratio (SCR) at the ac connection point is an important parameter, and has to be checked when installing an LCC HVDC transmission scheme. The SCR is defined by the following: $SCR = P_{sc} / P_{dc}$, where P_{sc} is the short-circuit power at the connection point, and P_{dc} is the nominal dc power of the transmission. A certain minimum SCR is required for stable operation of an LCC HVDC scheme. This is because an active power change causes an equivalent reactive power change, resulting in an ac system voltage fluctuation. A voltage drop in the ac system causes additional reactive power consumption and thus further voltage drop. This phenomenon is known as voltage instability. To avoid voltage instability, an SCR of more than 2 would typically be required [14-1].

The VSC does not have any limit on the SCR for stable operation, since the VSC can control both active power and ac voltage magnitude, within the overall rating limits, by utilising its reactive power capability. This capability is an essential requirement for the supply of power to a network that has no generation (a dead network), or where the generation is remote and connected through long, high-impedance circuits. The amount of the active power transfer of a VSC scheme is limited only in accordance with normal ac system theory. Thus, as a close approximation the maximum active power that can be injected in an ac system is $1/X_{system}$, where X_{system} is the per unit reactance of the ac system viewed from the VSC's ac terminals.

14.2.4 Harmonics and Filter Requirements

The basic unit of the LCC is a three-phase bridge converter. Since the LCC uses the ac system voltage for commutation, the number of turn-on/turn-off operations at each arm is one per power frequency cycle. Harmonic currents of orders $(6n \pm 1)$ are generated from the three-phase bridge converter. 12-pulse converters are widely applied by combining two three-phase bridges, one with the converter transformer y-y connected and the other y-d connected. Theoretically, this arrangement cancels some of the harmonic currents and only the order of $(12n \pm 1)$ remains. Nevertheless, harmonic filters are necessary to keep the voltage distortion, or harmonic current injection to the ac system, at an acceptable level. The amount of filter capacity needed to limit harmonics depends upon the system impedance. The typical capacity of filter banks would be 20% to 30% of the converter rating. These filters are normally part of the reactive power compensation capacitor banks.

In contrast, the VSC uses turn-off devices as switches, and the number of switchings at each arm per cycle is not limited to one. When a higher number of switching operations is used (a few kHz), the harmonic generation at lower harmonic orders can be reduced. Depending on the system impedance and the amount of switching per converter arm, a filter may not be required, or perhaps only a small one to absorb the higher harmonics, or to reduce the interference to the VSC from background distortion and unbalance in the ac system. However, since power losses increase along with switching frequency, the optimum switching number is determined after taking these factors into account.

The VSC scheme can also be designed with additional degrees of freedom in the ac waveform to provide active filtering of ac system harmonics and/or to suppress flicker from industrial processes. It may be necessary to increase the converter rating in order to handle such additional duties.

14.2.5 Overvoltages in the AC System

As mentioned above, the LCC HVDC requires substantial filter and shunt capacitor banks. When the LCC stops operation due to a fault or other reason, its reactive power absorption becomes 0, resulting in an ac overvoltage due to the surplus reactive power from the shunt capacitor and filter banks. In addition to the fundamental frequency overvoltage, resonance type overvoltages may also appear if the system impedance is relatively high.

Since any filters associated with the VSC will normally have a low rating, large overvoltages are not

caused when a VSC Transmission scheme stops working, unless the VSC was absorbing a considerable amount of reactive power before stopping.

14.2.6 Robustness against AC System Faults

If an ac system fault occurs in the inverter side network, the LCC might suffer a commutation failure, which could result in a temporary interruption in power transmission. Even if the fault is one phase to ground, the power reduction might be 100% since continuous commutation failures can occur. This is one of the disadvantages of the LCC.

In contrast, the VSC can continue to transfer active power, limited by the severity of the ac system fault, provided that the VSC control is fast enough to avoid unacceptable overcurrent due to the sudden voltage changes in the ac system.

14.3 DIFFERENCES RESULTING FROM THE SOURCE TYPE

This section presents the differences between the two technologies that are determined by the type of converter used, i.e., a current sourced converter or voltage sourced converter.

14.3.1 Protection against DC System Faults

If faults occur in the dc system, the LCC can limit the overcurrent easily by its dc current control function, and then clear the fault by action of the thyristor valve control and protection. A dc circuit breaker is not required for a two-terminal HVDC system. After the de-ionisation period, the HVDC system can be restarted relatively quickly (100 ms to 300 ms).

In the case of VSC Transmission, the free-wheeling diodes used in the VSC will cause dc current to continue to flow into the fault, even if the IGBTs are blocked. Therefore, to clear the fault it is necessary to open the ac circuit breakers at all terminals. Only circuit breakers at the ac sides of the converter transformers can clear the faults if dc circuit breakers are not available. Fast tripping of the ac circuit breakers would be required. It would take a relatively long time to restore the system, since it is necessary to charge the DC system to the rated voltage again before restarting. See Chapter 6.13.

14.3.2 Flexibility of the Power Flow Reversal in the Multi-Terminal HVDC System

It is not possible to change the dc current direction in an LCC HVDC scheme. To reverse the flow of power, a polarity change of the dc system voltage is necessary. This is not a problem in a two-terminal HVDC system. However, the need for voltage reversal to change power direction means that some of the low cost extruded polymeric cable designs cannot be used with LCC HVDC. In a multi-terminal HVDC system, however, the polarity change of the dc system voltage would mean a power flow reversal at all terminals, although normally the power flow will be reversed at only one or two terminals. To accomplish this, mechanical switches are needed to reverse the dc terminals and the converters must be provided with full insulation at both terminals.

In a VSC Transmission scheme the voltage polarity is constant and the power direction is changed by changing the current direction. Therefore, in a multi-terminal scheme it is possible to change the power direction at each terminal very rapidly and without switching operations [14-2]. The coordination between the different converters becomes relatively simple, and fast telecommunication between the terminals may not be required for VSC Transmission schemes.

14.3.3 Cost, Losses, Reliability and the Availability of the Large Scale HVDC System

The development of VSC technology has been remarkable. At present, however, LCC HVDC is superior to VSC Transmission in terms of capital cost and power losses for large-scale HVDC systems. Reliability and availability information for LCC HVDC has been collected by CIGRÉ for many years, and the evidence shows that this technology performs very well. Similar information has not yet been collected for VSC Transmission. The relative superiority of LCC HVDC systems is likely to decline as VSC Transmission technology develops and costs go down. VSC Transmission can also utilize low cost polymeric cables, which are not required to withstand polarity reversal.

14.4 SUMMARY

Table 14.1 shows a comparison between LCC HVDC and VSC Transmission in tabular form.

Table 14.1 (1) Summary comparison between LCC HVDC and VSC Transmission

	LCC HVDC	VSC Transmission
Harmonics and filter requirements	Filter banks are required to absorb the $(12n \pm 1)$ harmonic currents on the ac side. For overhead lines, filters are required to absorb $12n$ harmonics on the dc side. Additional filters may be required to deal with non-characteristic harmonics on both the ac and the dc side.	Increasing the number of the switchings per cycle can reduce the harmonic generation. Physically small filters can be used on the ac and dc side.
Overvoltages in the ac system	A sudden LCC HVDC stop can cause fundamental frequency overvoltages, sometimes exacerbated by resonance.	Due to the use of small ac filters, the overvoltage, if any, will be smaller than in the case of an LCC HVDC scheme
Robustness against the ac system faults	In the event of an ac system fault, the scheme may suffer a temporary commutation failure. If the fault is close, transmission may stop until the ac system fault is cleared.	VSC Transmission can not suffer from commutation failures, and the scheme can continue to transfer some power, subject to the current rating limit of the converter. If the fault is very close, transmission may stop until the ac system fault is cleared.
Cost, losses, reliability and the availability of the large scale HVDC system	Better at present	The differences are decreasing because of improvements in VSC technology.
Protection against the dc system faults	Fast restart is possible.	Fast restart is difficult without dc circuit breakers.
Flexibility of power flow reversal in multiterminal schemes	Power flow reversal at each terminal requires mechanical switching operation.	Power flow reversal at each terminal is easy.



Shading shows the superior part.

Table 14.1 (2) Summary comparison between LCC HVDC and VSC Transmission

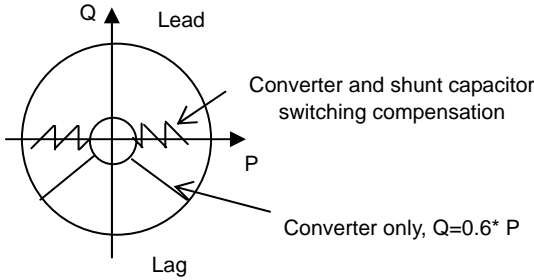
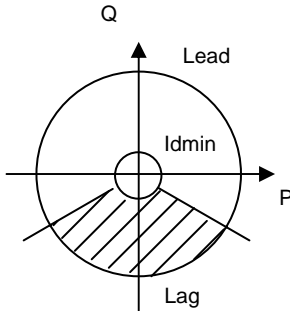
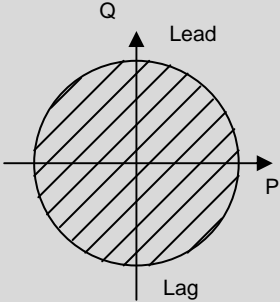
		LCC HVDC	VSC Transmission
Requirement for ac system	Dependence on an ac voltage source	An ac voltage source is mandatory. If there is no generation, a synchronous compensator or a VSC is required for the operation of LCC.	A voltage source is not required.
	Reactive power consumption or generation	<p>LCC HVDC consumes reactive power of 50% to 60% of the active power. Switchable shunt capacitor banks are necessary for reactive power compensation.</p>  <p>For BTB system, there is some flexibility in reactive power control (as shown in the hatched area) by reducing the dc voltage. It should be noted, however, that such reactive power control at one terminal affects the reactive power consumption at the other terminal, since the dc voltage is common. Due to the minimum dc current, $I_{d \min}$ (usually 10% of the rated current), there is also a limitation on minimum reactive power.</p>  <p>For HVDC with DC transmission line, however, the hatched area should be deleted since for the converter only, $Q=0.6*P$ and no degree of freedom exists. The above diagram corresponds to the converter only.</p>	<p>Reactive power can be generated or absorbed.</p> <p>Reactive power can be controlled independently from active power control at both ends of the VSC Transmission scheme.</p> 
	Short circuit ratio (SCR)	In general, a SCR of more than 2 is required for stable operation.	There is no special limit on SCR.



Shading shows the superior part.

14.5 REFERENCES

- [14-1] CIGRÉ Working Group 14.07, “Guide for Planning DC links terminating at AC locations having low short-circuit capacities, Part I: AC/DC interaction phenomena.” CIGRÉ Brochure No. 68, 1992.
- [14-2] Nakajima, T., Irokawa, S., “A Control System for HVDC Transmission by Voltage Sourced Converters.” *Proceedings, IEEE Power Engineering Society Summer Meeting*, Vol. 2, pp. 1113-1119, 1999.

15. VSC TRANSMISSION OUTLOOK

15.1 INTRODUCTION

The VSC Transmission technology commercially available at the end of 2004 uses VSC valves with high power transistors of the IGBT type. The highest transmission capacity in operation that year was 330 MW and ± 150 kV dc. By the end of 2004 six VSC Transmission schemes and one back-to-back scheme were in operation worldwide. Of these, five schemes have a transmission capacity of less than 100 MW and two have a capacity above 100 MW. (See Appendix A for more information about these schemes.) As VSC Transmission technology is presently in a state of rapid development, different technical solutions may appear in the next few years.

15.2 FUTURE TRENDS

VSC Transmission is a relatively new technology compared with the conventional LCC HVDC transmission, which has existed for about five decades. Given VSC Transmission's great promise to become the technology of the future, it is worthwhile identifying the trends that would help it to develop further. The following are some areas that the Working Group believes are likely lead to more widespread use of VSC Transmission.

15.2.1 Reliability

The use of VSC technology in transmission applications has been successfully demonstrated in a number of full-scale installations, as shown in Appendix A. However, because of the youth of the technology and the few schemes in operation, it is not yet possible to demonstrate that VSC Transmission can provide reliability and availability comparable to or better than LCC HVDC transmission. It is expected that this will soon be demonstrated, as new projects are commissioned and more service experience is accumulated. It is recommended that CIGRE begin to record reliability and availability data for VSC Transmission schemes, as is currently done for LCC HVDC.

15.2.2 Capital Cost of a VSC Transmission Installation

Since the power electronics in an existing VSC Transmission installation make up a higher proportion of its total capital cost than they do in a typical LCC HVDC installation, the ongoing development in semiconductors and VSC technology is expected to have a more significant impact on the capital cost of VSC Transmission than LCC HVDC.

15.2.3 Controllable Switching Components

One trend in silicon-based IGBT development is toward higher rated voltage capability. Increasing the voltage capability will reduce the number of series-connected components required in the VSC valve. This will likely reduce the cost of the valve, provided that the current capability can be maintained. In order to maintain the current capability, larger semi-conductor areas will probably be required.

By the end of 2004, the rated voltage of the silicon-based turn-off IGBTs had reached about 6.5 kV. However, VSC Transmission requires press-pack devices, and for these the maximum rated voltage was limited to 4.5kV. As the market for VSC Transmission grows, the development of high-voltage press-pack devices will become more attractive.

However, as the device voltage increases so does the capital cost and power loss per device. This is offset by the need for fewer series-connected devices in the VSC valve. As mentioned above, larger area devices will be required, and it is expected that overall cost and power losses for the VSC valve will decline while its voltage rating increases.

Figures 15.1 and 15.2, from a semiconductor manufacturer, show the manufacturer's view of the history and expected future development of controllable switching components.

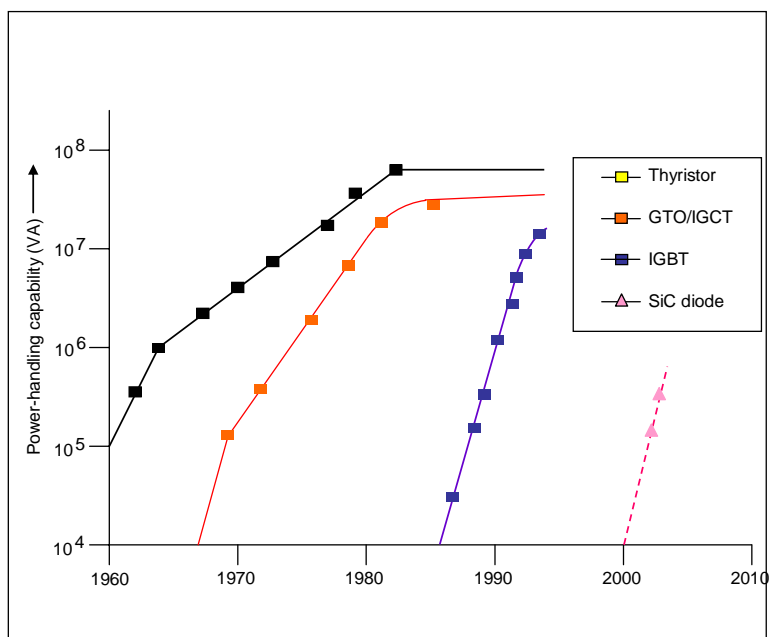

Figure 15.1: Development trends in controllable switches

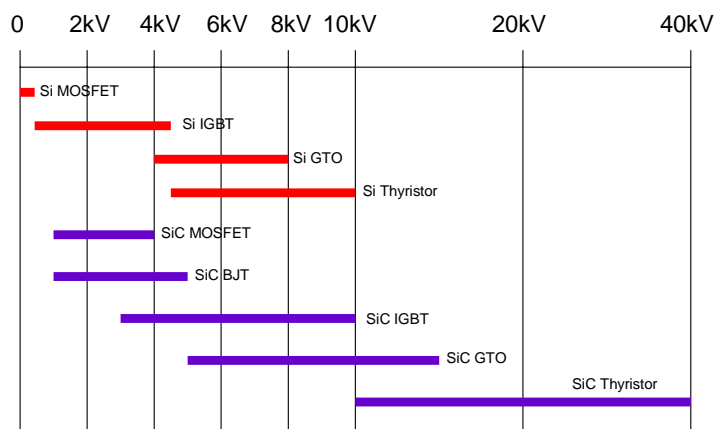

Figure 15.2: Silicon carbide (SiC) switches compared to silicon (Si) switches

In the coming decade, new generation devices, based on wide band gap materials such as silicon carbide or perhaps later gallium nitride (GaN), are expected to provide superior performance on several fronts.

Significantly increased device voltage rating appears to be possible. This would result in a reduction of the number of series-connected devices in the VSC valve and allow either higher MVA ratings for VSC installations, or more compact converters. Furthermore, because there would be fewer series components, reliability and maintenance costs should improve.

Such devices could also increase the peak junction temperature at which full control of the device can be maintained to about 200°C. This would result in a dramatic increase in the surge capability of the device and the possibility of simpler and less costly cooling systems.

Switching losses could also be dramatically reduced, making it possible to considerably increase the 2 kHz operating frequency of today's silicon devices. Higher frequency could further reduce the size of the harmonic filters.

15.2.4 Power Losses

Power losses in VSC schemes today are significantly higher than those for LCC HVDC. This is largely due to higher power losses in the converters. Improvements in semiconductor and VSC technology should considerably reduce the power losses for VSC Transmission.

15.2.5 Increased DC Voltage and Power Rating of DC Extruded Cables

VSC Transmission technology can make use of power cables that are not required to withstand voltage reversal (steady state or transient). These extruded polymeric cables may be easier to install on land and of lower cost than oil-impregnated cables.

Cable installations are usually considered more environmentally benign than overhead lines. VSC scheme reliability is also likely to improve with the use of cables, since cables are not subject to frequent faults from lightning or pollution. At the end of 2004 the maximum commercially available voltage rating for extruded polymeric dc cables was 150 kV dc.

Further research and development aimed at increasing the voltage rating of cable technology and reducing its cost may make VSC Transmission more attractive for a number of applications.

15.2.6 Utilisation of the Functionality and Controllability of VSC Transmission

A VSC Transmission scheme has the unique capability of providing independent control of reactive power and supporting transmission voltage and real power transfer at its terminals. This feature opens up new and visionary opportunities for the application of VSC Transmission.

One can envision, for example, "implanting" a VSC scheme to support an existing ac grid. VSC Transmission could provide flexibly-controlled interconnections for ac grid areas and, at the same time, robust voltage supports at the points of interconnection. In this way the VSC Transmission could improve the controllability, flexibility and stability of ac grids (see [15-1]). In addition, the converters could be used for active filtering of low-order harmonics in the ac network. Further functionality could be provided when economic energy storage becomes available.

Because VSC Transmission does not require the direct voltage to be reversed when the power direction is changed, and does not suffer from commutation failures, it is well suited to multi-terminal applications.

VSC Transmission technology is suitable for the use of standardised modules, since its implementation can be less dependent on the specific network conditions than is the case for LCC HVDC. Furthermore, less extensive study of the interaction between the VSCs and the ac grids may be acceptable (except where special system network conditions prevail), because self-commutating VSCs can operate with a fully controlled power factor, a high speed of response, and without generating low-order harmonics. These capabilities also mean that VSC Transmission is well suited for unusual network conditions, where specific studies may be necessary to optimise the control settings.

15.3 REFERENCES

- [15-1] Johansson S.G., Asplund G., Jansson E., Rudervall R., "Power system stability benefits with VSC DC transmission systems." CIGRÉ Paper B4-204, 2004.

16. CONCLUSION

VSC Transmission, which is based on voltage sourced converter technology used extensively for large motor drives, became a reality with the 3-MW demonstration project at Hellsjön, Sweden, in 1997. Since then, the technology has been further developed and had, by the end of 2004, reached a dc power level of 330 MW at ± 150 kVdc, with a single converter. The total in-service rating of VSC Transmission schemes at the end of 2004 was 813 MW—a much more rapid growth than occurred with the first generation of HVDC transmission, the line-commutated converter technology (LCC HVDC).

Inherently, VSC Transmission technology has many advantages over LCC HVDC:

- Reactive power can be controlled independently of real power at each terminal.
- The power delivery from VSC Transmission is less dependent on the ac network short-circuit power than an LCC HVDC scheme.
- VSC Transmission can deliver power to a passive ac network.
- VSC Transmission is well suited to multi-terminal operation.
- VSC substations can be designed to be very compact.
- VSC Transmission will not suffer commutation failures during faults and disturbances in the ac network.
- VSC Transmission is well suited for transmission using extruded cables, which do not need to be able to withstand polarity reversal.
- VSC substations can be designed to provide additional features that may be valuable, e.g., ac harmonic mitigation, phase unbalance compensation and flicker mitigation.

At present, a VSC substation has significantly higher power losses than an LCC HVDC substation. Ongoing development and new generations of semiconductors may provide or enable significant reductions in power losses for VSC Transmission. Multi-level converters and other converter topologies can also decrease power losses, but these may increase capital cost and space, which must be taken into account in the overall optimisation.

In some cases, the benefits resulting from the characteristics of a VSC Transmission scheme will more than offset the disadvantage of the higher power losses.

It is clear that the prospect of achieving future cost reductions for VSC Transmission is much greater than for the mature LCC HVDC technology. This is to some extent due to the rapid development and improvement in semiconductor technology, as well as in the general voltage sourced converter technology.

The Working Group has not identified any technical reason why, in principle, VSC Transmission cannot be developed for very high direct voltage and power, say 500 kVdc, 3000 MW. However, whether or not such research and development is done will depend on the projected cost of the developed product and the demands of the marketplace.

Working Group B4-37 believes that VSC Transmission will become increasingly attractive as the technology develops and matures. As a consequence, not only will the niche applications mentioned in the foreword become more numerous, but VSC Transmission will gradually encroach more and more on the LCC HVDC market, and the number of applications within ac networks will increase.

When this Working Group was set up in 2001, VSC Transmission was at a relatively early stage of development, so it was not considered appropriate to give detailed guidance on the test requirements for VSC Transmission systems or for the individual equipment in such schemes. Since then, however, VSC Transmission has become more established and schemes with power ratings of more than 300 MW and up to ± 150 kVdc are in service.

The Working Group recommends that other CIGRE Working Groups be established to provide guidance on:

- Testing of VSC Substation equipment
- Determination of power losses for VSC Transmission
- Harmonic filtering for VSC Transmission

The Working Group also recommends that the reliability and availability performance of VSC Transmission schemes be collected and reported by the Advisory Group B4-AG-04 (HVDC Performance).

APPENDIX A: LIST OF VSC TRANSMISSION SCHEMES

Scheme name	HVDC Tjuja-Ashu-Susamyr
Utility or customer	Regional PS of Kirgiziya SSR
Reason for selecting VSC	Experimental HVDC transmission for research of VSC technology and its application for power supply of loads in isolated areas and in challenging environmental conditions. HVDC transmission was taken out of service in 1995.
Manufacturer	Manufactures of USSR
Rated power	3.2 MW
DC voltage	14 kV
AC voltage at connection points	35 kV @ 50 Hz
Location of end stations	USSR, Kyrgyzstan
Year of commissioning	1984
Converter topology	2-level
VSC valve type	ETT (Electrically Triggered Thyristors) with forced commutation
Modulation type	6-pulse
Telecommunications	No telecommunication between end stations for regulation
DC cable / line	3.5 km cable / 22 km overhead line
Miscellaneous	Monopolar Standard transformers
Specific control modes	DC voltage control
Single line diagram	
Photos	
Website	
Bibliographic reference	Preobrazhensky, A.S., Sariyev, I.S., Topelberg, V.V., "Analysis switching operations of HVDC with autonomous voltage inverter," <i>Electrichestvo</i> , No. 2, 1990. (in Russian)

Scheme name	Hellsjön HVDC Light
Utility or customer	VB Elnät, Sweden
Reason for selecting VSC	Technology Demonstrator
Manufacturer	ABB
Rated power	3 MW / 3 MVar
DC voltage	± 10 kV
AC voltage at connection points	10 kV @ 50 Hz at both ends
Location of end stations	Sweden, Hällsjön and Grängesberg
Year of commissioning	1997
Converter topology	Single 2-level phase unit
VSC valve type	IGBT
Modulation type	PWM at 1950 Hz
Telecommunications	No telecommunication between end stations for regulation
DC cable / line	Overhead line
Miscellaneous	Test installation, VSC valves and controls indoors. Fast DC switches are included. Balanced bipolar Unmanned stations Standard transformer
Specific control modes	
Single line diagram	
Photos	
Website	http://www.abb.com/global/abbzh/abbzh251.nsf!OpenDatabase&db=/global/gad/gad02181.nsf&v=17EA&e=us&c=C1256D71001E0037C1256A0A00430AAA
Bibliographic reference	Asplund, G., Eriksson, K., Jiang, H., Lindberg, J., Pålsson, R., Svensson, K., "DC transmission based on Voltage Source Converters." CIGRÉ, 1998.

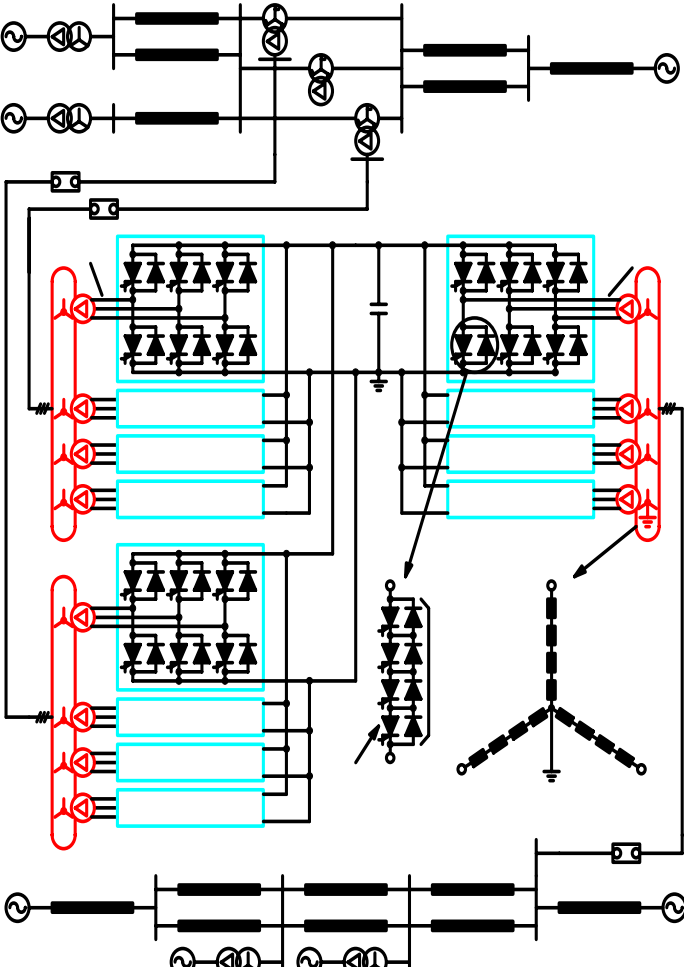
Scheme name	Interconnection reinforcement project
Utility or customer	10 power utilities and CRIEPI, Japan
Reason for selecting VSC	Development prototype for a 300 MW multi-terminal (3-terminal) back-to-back VSC system. A field test at a 500-kV/275-kV substation has been conducted. This 53-MVA test scheme is used to verify control performance of the final scheme. This project is not in commercial operation.
Manufacturer	Hitachi, Toshiba and Mitsubishi
Rated power	53 MVA / 37.5 MW / ± 37.5 MVar
DC voltage	0 / 10.6 kV
AC voltage at connection points	66 kV (2 terminals @ 50 Hz side) / 275 kV (1 terminal @ 60 Hz side)
Location of end stations	Japan, Shin-shinano substation (Shin-shinano Frequency Converter Station)
Year of commissioning	1998
Converter topology	4-stage, 2-level
VSC valve type	GTO
Modulation type	PWM at 9 th harmonic \times 4 converters (4 \times 9 \times 50/60 Hz)
Telecommunications	Not applicable, (back-to-back scheme)
DC cable / line	Back-to-back scheme
Miscellaneous	
Specific control modes	APR (Automatic Power Regulator) / DC – AVR (Automatic Voltage Regulator) AC – AVR (Automatic Voltage Regulator) / AQR (Automatic Reactive Power Regulator)
Single line diagram	

<p>Photos</p>	 <p>The first photograph shows a vertical rack of three VSC units, each with a yellow frame and internal components. The second photograph is a cutaway view of a VSC unit, revealing its internal structure, including a white metal frame, various electronic components, and a large capacitor bank. The third photograph shows a large, white cabinet with two doors, flanked by two racks of VSC units, all mounted on a metal base.</p>
<p>Website</p>	
<p>Bibliographic reference</p>	<p>Hayashi, T., Seki, N., Sampei, M., Sekine, Y., "Development and Field Test of a Multi-terminal DC Link Using Voltage Sourced Converters and New Control and Protection Schemes." CIGRÉ Paper No. 14-204, 2000.</p>

Scheme name	Gotland HVDC Light Project
Utility or customer	GEAB subsidiary of Vattenfall AB, Swedish National Energy Administration
Reason for selecting VSC	Main reasons for choosing HVDC system: Wind power (voltage support). Easy to get permission for underground cables.
Manufacturer	ABB
Rated power	65 MVA / 50 MW / ± 30 MVar
DC voltage	± 80 kV
AC voltage at connection points	70 kV @ 50 Hz at both ends
Location of end stations	Sweden, Näs – Bäcks, connection of Näs windfarm to the city of Visby
Year of commissioning	1999
Converter topology	2-level
VSC valve type	IGBT
Modulation type	PWM at 1950 Hz
Telecommunications	No telecommunication between end stations for regulation, scheme is remotely controlled
DC cable / line	2 \times 70 km underground extruded polymer dc cables
Miscellaneous	Parallel to an ac connection Bipolar Unmanned stations Standard transformers
Specific control modes	Active and reactive power control, ac voltage control, power quality control
Single line diagram	
Photos	
Website	http://www.abb.com/GLOBAL/ABBZH/ABBZH262.nsf/viewunid/1524DDBB0CCFCF75C12568350058A224/\$file/gotland_hvdcilight_project.pdf

Bibliographic reference	Axelsson, U., Holm, A., Liljegren, C., Eriksson, K., Weimers, L., "Gotland HVDC Light Transmission - worlds first commercial small scale dc transmission." CIRED, Nice, France, 1999.
-------------------------	---

Scheme name	Tjæreborg HVDC Light
Utility or customer	Eltra, Denmark
Reason for selecting VSC	Main reasons for choosing HVDC system: Wind power. Demonstration project
Manufacturer	ABB
Rated power	8 MVA / 7.2 MW / -3 +4 MVar
DC voltage	± 9 kV
AC voltage at connection points	10.5 kV @ 50 Hz at both ends
Location of end stations	Denmark, Tjæreborg – Enge, connection of Tjæreborg windfarm to the network
Year of commissioning	2000
Converter topology	Single 2-level phase unit
VSC valve type	IGBT
Modulation type	PWM at 1950 Hz
Telecommunications	No telecommunication between end stations for regulation
DC cable / line	2 \times 4.3 km underground cable, aluminium 240 mm ² , extruded polymer
Miscellaneous	VSC valves and controls indoors. Other equipment in a barn-type area. The dc scheme is in parallel to an ac connection. Balanced bipolar Unmanned stations Remote control of Enge converter Dry type transformer (epoxy insulation)
Specific control modes	AC voltage control of an isolated windfarm Power frequency control (30-65 Hz) Automatic start when wind generated power > 700 kW
Single line diagram	<p>The diagram illustrates the power flow from the Tjæreborg Enge windfarm (10.5 kV AC) through a transformer to a bipolar VSC converter (8 MVA). The DC link consists of two parallel cables (7.2 MW each) with a total DC voltage of ± 9 kV. This is followed by a second 8 MVA VSC converter and another transformer, connecting to the Tjæreborg Substation (10.5 kV AC).</p>
Photos	<p>The photograph shows the physical installation of the HVDC Light system. A large red barn-like structure houses the VSC converters. In the foreground, several black and white cows are grazing in a green field. In the background, several wind turbines are visible, indicating the connection to the windfarm.</p>

Website	http://search.abb.com/library/ABBLibrary.asp?DocumentID=POW-0024&LanguageCode=en&DocumentPartID=&Action=Launch
Bibliographic reference	Soebrink, K., Soerensen, P.L., Christensen, P., Andersen, N., Eriksson, K., "DC Feeder for Connection of a Wind Farm." CIGRÉ Symposium Paper 500-06, Kuala Lumpur, Malaysia, 1999.

Scheme name	Directlink HVDC Light
Utility or customer	TransÉnergie U.S., a subsidiary of Hydro-Québec & North Power
Reason for selecting VSC	Controlled asynchronous connection for trading. Easy to get permission for underground cables.
Manufacturer	ABB
Rated power	195 MVA / 180 MW / ± 75 MVar
DC voltage	± 80 kV
AC voltage at connection points	110 kV and 132 kV @ 50 Hz
Location of end stations	Australia, Tweed Valley (Queensland) – New South Wales
Year of commissioning	2000
Converter topology	2-level
VSC valve type	IGBT
Modulation type	PWM at 1950 Hz
Telecommunications	No telecommunication between end stations for regulation
DC cable / line	6 \times 59 km underground, extruded polymer, aluminium 630 mm ²
Miscellaneous	3 parallel systems Bipolar Standard 70 MVA transformer
Specific control modes	Active and reactive power control, ac voltage control
Single line diagram	
Photos	

Website	http://www.transenergie.com.au/june/direct/directlink.html
Bibliographic reference	Railing, B.D., Moreau, G., Wasborg, J., Stanley, D., Miller, J.J., Jiang-Hafner, Y., "The Directlink VSC-based HVDC project and its commissioning." CIGRÉ, 2002.

Scheme name	Eagle Pass
Utility or customer	Central and South West Corporation / CSW's Central Power and Light Company & Comisión Federal de Electricidad (CFE)
Reason for selecting VSC	Controlled asynchronous connection for trading. Voltage control
Manufacturer	ABB
Rated power	36 MVA / 36 MW / ± 36 MVar
DC voltage	± 15.9 kV
AC voltage at connection points	138 kV @ 60 Hz at both ends
Location of end stations	Mexico-USA border, Eagle Pass
Year of commissioning	2000
Converter topology	3-level NPC
VSC valve type	IGBT
Modulation type	PWM at 1500 Hz
Telecommunications	N/A
DC cable / line	N/A (back-to-back)
Miscellaneous	Connected in series in the ac line from Eagle Pass to Piedras Negras May be operated either as a 36 MW dc transmission, two ± 36 MVar independent STATCOMS, or one ± 72 MVar STATCOM
Specific control modes	Active and reactive power control, with priority given to Q
Single line diagram	<p style="text-align: center;">Eagle Pass HVDC Light 138 kV, 36MVA</p>

Photos	
Website	http://www.abb.com/GLOBAL/ABBZH/ABBZH262.nsf/viewunid/3DE8E33967D829BCC1256974002E191E/\$file/Eagle+Pass+A02-0174E.pdf
Bibliographic reference	

Scheme name	Murray Link HVDC Light Project
Utility or customer	Murraylink Transmission Company Pty. (TransÉnergie Australia), a subsidiary of TransÉnergie
Reason for selecting VSC	Controlled asynchronous connection for trading. Easy to get permission for underground cables.
Manufacturer	ABB
Rated power	200 MW / +140 –150 MVar
DC voltage	± 150 kV
AC voltage at connection points	132 kV and 220 kV @ 50 Hz
Location of end stations	Australia, Victoria – South Australia
Year of commissioning	2002
Converter topology	3-level NPC
VSC valve type	IGBT
Modulation type	PWM at 1350 Hz
Telecommunications	Communication between end stations for operation (sequences, runback)
DC cable / line	2 × 180 km underground extruded polymer dc cable
Miscellaneous	Weak ac network operation (SCR=1.3) Bipolar Unmanned stations Standard transformers
Specific control modes	Active and reactive power, ac voltage control, runback, low order harmonic cancellation
Single line diagram	<p>Monash Berri Red Cliffs</p>
Photos	
Website	http://www.transenergie.com.au/june/murray/murraylink.html
Bibliographic reference	Mattsson, I., Ericson, A., Railing, B.D., Miller, J.J., Williams, B., Moreau, G., Clarke, C.D., Lavalin, S.N.C., “MurrayLink, The Longest Underground HVDC Cable in the World.” CIGRÉ, 2004.

Scheme name	Cross Sound HVDC Light Project
Utility or customer	TransÉnergie U.S., a subsidiary of Hydro-Québec
Reason for selecting VSC	Controlled connection for trading. Submarine cables without oil.
Manufacturer	ABB
Rated power	346 MVA / 330 MW / ± 75 MVA _r
DC voltage	± 150 kV
AC voltage at connection points	345 kV and 138 kV @ 60 Hz
Location of end stations	USA, Long Island – Connecticut, New York State
Year of commissioning	2002
Converter topology	3-level NPC
VSC valve type	IGBT
Modulation type	PWM at 1260 Hz
Telecommunications	Communication between end stations for operation
DC cable / line	2 \times 40 km submarine extruded polymer dc cable
Miscellaneous	Bipolar Unmanned stations Standard transformers
Specific control modes	Active and reactive power, ac voltage control, runback, low order harmonic cancellation
Single line diagram	
Photos	
Website	http://www.crosssoundcable.com/
Bibliographic reference	Railing, B.D., Miller, J.J., Steckley, P., Moreau, G., Bard, P., Ronstrom, LI, Lindberg, J., "Cross Sound Cable Project, second Generation VSC Technology or HVDC." CIGRÉ, 2004.

Scheme name	Troll A Precompression Electrical drive system
Utility or customer	STATOIL Norway
Reason for selecting VSC	To provide an Electrical Drive System for the compressor motors; i.e., with the ability to feed and regulate these passive loads. Low weight and volume
Manufacturer	ABB
Rated power	40 MW mechanical shaft power
DC voltage	± 60 kV
AC voltage at connection points	132 kV @ 50 Hz and 56 kV @ 0-63 Hz
Location of end stations	Norway, Kollsnes and Troll A platform
Year of commissioning	2004
Converter topology	2-level
VSC valve type	IGBT
Modulation type	PWM at 1950 Hz
Telecommunications	Communication between end stations for operation and platform security
DC cable / line	4 \times 70 km submarine extruded polymer dc cable
Miscellaneous	Two parallel systems Unit connection with a motorformer Compressor drive with variable frequency (0-63 Hz) on the platform offshore The VSC converter is built in a platform module Bipolar Manned stations Standard transformer on shore
Specific control modes	Drive system control, Torque and speed control
Single line diagram	<p>The diagram illustrates the electrical drive system for the Troll A platform. It starts with 'Existing equipment' consisting of a '132 kV Switchboard' and 'Bay 8'. This is connected to a 'Power Transformer' leading to the 'Kollsnes HVDC Light Rectifier'. The DC link is a 'Subsea Cable, HVDC Light Cable'. On the 'Troll A platform', there is an 'HVDC Light Inverter' connected to a '40 MW 56 kV Powerformer Motor'. The motor is connected to a 'Gear' and a 'Pre-compressor'. A note states 'Not part of ABB Scope Pre-compressor'.</p>
Photos	
Website	
Bibliographic reference	Hyttinen, M., Lamell, J.O., Nestli, T.F., "New Application of Voltage source converter (VSC) HVDC to be installed on the gas platform Troll A." CIGRÉ, 2004.

APPENDIX B: FUNCTIONAL SPECIFICATION FOR A VSC TRANSMISSION SYSTEM

1. INTRODUCTION

This appendix presents the minimum requirements of a functional specification for a VSC Transmission system. Once the technical requirements of the VSC Transmission have been defined and confirmed by basic system studies, a functional specification can be prepared. Supplemented by the commercial conditions, the specification allows the utility to invite tenders from manufacturers for the equipment required. The functional specification must provide adequate information exchange between the utility, the manufacturers and relevant subcontractors.

The specification should include areas where a minimum requirement is specified, as well as those areas where a performance above the minimum standard is required but is optional. The specification should include a method for evaluating the above-minimum performance criteria.

In the following sections the minimum technical information which needs to be provided by the utility and manufacturer are summarized. These summaries describe:

- General requirements of the VSC Transmission system
- Power system characteristics of the sending and receiving end systems to which the VSC Transmission system is connected, including all the parallel transmission systems, if any
- Steady-state performance requirements
- Dynamic performance requirements, including control and monitoring facilities
- Transient performance
- Maintenance, performance tests and spare parts requirements
- Converter site, transmission right of way, and environmental constraints and considerations
- Requirements of the dc line, i.e., type of cable or overhead line or combination thereof. If the dc line is not within the scope of supply, the converter manufacturer should provide information that would be needed for a proper line specification. The type of line chosen should be approved by the converter manufacturer as to its applicability.
- Other considerations relating to loss evaluation, tender evaluation, health and safety, and other ancillary requirements

The utility must provide a detailed description of the power systems connected to the VSC Transmission system to enable the suppliers to offer the most suitable and economic equipment design. In addition, the utility and the manufacturer must maintain a continuous dialogue starting at the tender stage and continuing until the project is completed. It is recommended that the manufacturer should review the basic studies undertaken by the utility, and vice versa.

2. UTILITY AND MANUFACTURER INFORMATION REQUIREMENTS

In the following tables, information marked with an asterisk (*) may require detailed studies that may not be available before the contract stage.

For some parameters, time varying data may be appropriate, e.g., the range of ac system rms voltage may include excursions outside a normal range during brief periods (hours, minutes, seconds or milliseconds) with different limits for each duration. Such time varying data must be described in an appropriate manner.

The confirmation of performance may be demonstrated by any one or a combination of the following methods:

- Studies

- Tests
- Calculations

2.1 General Requirements

Utility Specification Requirement	Manufacturer Supplied Information
Broad statement of role of the VSC Transmission scheme, e.g.: <ul style="list-style-type: none"> • Location of the scheme terminals • Single line diagram of user's connection points • Power to be transmitted • Type of dc line • Transmission voltage (if fixed) • Transient performance • Ancillary control requirements • Overload requirements • Critical dates • Losses 	General description of solution Device type and configuration Guaranteed performance data
Nominal sending and receiving system voltages Indication of the transformer winding configuration preference	Confirmation of performance with specified data
Reactive power regulation requirements	PQ-diagrams showing the operating region of the sending and the receiving end VSC converter Confirmation of the performance*
Scope of supply required Interfaces between the owner-supplied equipment/systems and the new equipment	Diagrams showing all major components and their method of connection to the system List of equipment, material and services provided and specific exclusions Component data including tolerances

2.2 Power System Characteristics

Utility Specification Requirement	Manufacturer Supplied Information
Range of system rms voltages at the sending and receiving busses	Confirmation of performance with specified data
Range of system frequency and rate of frequency change at the sending and receiving end	Confirmation of performance with specified data
Maximum and minimum short circuit levels at the points of connection	Confirmation of performance with specified data
Maximum fault clearance times	Confirmation of performance with specified data
Whether single- or three-phase auto reclosure is used, and if so, the timing of different periods	Confirmation of performance with specified data
Maximum harmonic voltage existing at the points of connection	Confirmation of performance with specified data *
Harmonic impedance envelopes at the points of connection	Confirmation of performance with specified data *
Maximum steady state phase imbalance at the points of connection	Confirmation of performance with specified data *
Ferroresonance consideration	Confirmation of performance with specified data
Requirement (if any) for model of the VSC Transmission scheme, with required format	Confirmation that a model in the specified format will be provided
Data on nearby generation and controllable devices	Confirmation of performance with specified data

2.3a DC Line/Cable (In case of Turnkey, supplied by the Prime Contractor)

Utility Specification Requirement	Manufacturer Supplied Information
Power to be transmitted, including overload requirement, if any Type of dc transmission line (cable or overhead line or a combination thereof) Length of the overhead line Length of the cable DC transmission voltage (if fixed)	Cable/OHL design parameters Cable/OHL design detail Current capability, steady state and overload (if any) Voltage withstand capability Overvoltage protection provided Proposed type tests including test levels
National safety codes/standards for design of overhead lines and cables	Confirm that design meets the requirements
Ambient conditions for overhead line <ul style="list-style-type: none"> • Air temperature range • Wind conditions • Ice loading requirements • Air pollution level • Risk of vandalism 	Confirmation of performance with specified data *
Information about the cable <ul style="list-style-type: none"> • Length of cable • Minimum required depth of burial • Survey data about the subsea/land terrain • Thermal resistivity of soil/silt/seabed • Temperature conditions • Requirement for fiber optic cable (whether imbedded or not) 	Confirmation of performance with specified data *
Location of nearby communication cables	Confirm there is no effect on communication cables

2.3b DC Line/Cable (Not supplied by the converter manufacturer)

Since the design of the converter and the cable are interdependent, the design process will be iterative. Therefore the data needs to flow between the VSC manufacturer and the cable supplier.

Utility Specification Requirement	Converter Manufacturer Supplied Information
Provide data from the dc line/cable supplier to the converter manufacturer	Maximum steady state, dynamic and transient current Maximum steady state, dynamic and transient voltage Harmonic voltage and current at the converter terminals Overvoltage protection provided Approval of selected dc line/cable system
Location of nearby communication cables	Confirm there is no effect on communication cables*
Requirement for converter data for cable manufacturer	Data provided

2.4 Steady-State Performance

Utility Specification Requirement	Manufacturer Supplied Information
Range of ac system conditions over which rated performance is required (e.g., frequency, phase imbalance, harmonics, impedance, fault level, system configuration)	Confirmation of performance over the range of operating conditions
Range of system conditions over which the transmission system must remain operational (e.g., voltage, frequency, unbalance, harmonics, system impedance to	Confirmation that the system remains operational and description of the performance

49 th harmonic, fault level, system configuration)	
Maximum harmonic emissions (voltage and current) for a range of system impedances at the sending and receiving end buses <ul style="list-style-type: none"> • Individual harmonic distortion D_n • Total harmonic distortion D • Telephone influence factor TIF 	Harmonics generated (voltage and current), filters and filter design criteria Measured values of: <ul style="list-style-type: none"> • Individual harmonic distortion D_n* • Total harmonic distortion D* • Telephone influence factor TIF*
Power system harmonic levels and switching transients and maximum permitted magnification	Confirmation of device immunity*
Maximum negative phase sequence (nps) and zero phase sequence (zps) emissions at fundamental frequency for a range of system impedances at points of connection	Levels of nps and zps generated*
System frequency range and rate of frequency change at both ends	System frequency range confirmation
Reliability and availability <ul style="list-style-type: none"> • Minimum technical life • Forced outage rate of system • Forced energy unavailability <ul style="list-style-type: none"> • Availability considering only scheduled maintenance requirements 	Life, reliability and availability characteristics, forced outage rates, maintenance frequency and periods Failure rate of key components, e.g., semiconductors, dc capacitors
Redundancy requirements	Depleted operating mode facilities, including control laws Transient effect of component failure

2.5 Dynamic Performance, Control and Monitoring Facilities

Utility Specification Requirement	Manufacturer Supplied Information
Maximum and minimum response times of the MW and Mvar output to the changes in set point and network configuration	Transient performance characteristics (overshoot, rise time, settling time) Device models for dynamic studies
Ability to ride through faults on dc and ac side, low voltage conditions and transient switching conditions	Description of performance during faults, other low-voltage conditions and switching transients Control logic and settings for operation during above conditions
Minimum short term overload requirements	Short term overload ratings
Control modes and control mode priorities, including requirements for ancillary control Control ranges (e.g., slope and set points) Measurement requirements	Device control modes and control laws, including details of control signals and their measurement methods
Remote and local control, alarm and monitoring requirements Data interface requirements	Description of remote and local man-machine interfaces, detailing control, alarm, communication and monitoring facilities* Adjustable parameters and their method of adjustment
Transient and temporary overvoltages, shape magnitude and duration System insulation levels	Overvoltage withstand capability Overload performance and protection Insulation coordination design
AC network protection standards, including requirements for coordination with other external protection	Description of protection system, including protection against internal failures Worst case internal faults in terms of duration and effect on VSC Transmission

Initial energization and shutdown requirements Auxiliary power and cooling facilities available	Auxiliary power facilities required and system description Method of initial energizing, restart and shutdown
--	--

2.6 Maintenance and Spares

Utility Specification Requirement	Manufacturer Supplied Information
Maintenance requirement	Maintenance frequency, duration and recommended maintenance
Special maintenance test equipment requirements	Special test equipment provided
Spares requirements	Recommended spares holdings
Drawings, maintenance manuals, technical notes	Description of documentation provided As-built drawings, maintenance manuals and technical notes provided*

2.7 Site and Environmental

Utility Specification Requirements	Manufacturer Supplied Information
Space and footprint restrictions Site accesses and transports limitations	Device layout and layout options Access and transport requirements
Electromagnetic field limitations Electromagnetic immunity requirements	Electromagnetic field generation Electromagnetic immunity levels*
System grounding conditions	Type of grounding and grounding requirements
Ambient temperature, pressure and humidity ranges	Ambient temperature, pressure and humidity capabilities
Solar, snow and ice, wind, air pollution, isokeraunic level and seismic conditions	Confirm operation under required conditions*
Noise restriction, acoustic and electromagnetic telephone interference restrictions	Noise level data Radio interference level and screening requirements

2.8 Factory and Commissioning Tests

Utility Specification Requirements	Manufacturer Supplied Information
Test requirements <ul style="list-style-type: none"> • Equipment requiring type test approval • Factory tests • Functional testing of control suites Complete system tests	Type test evidence offered in lieu of new type tests Test schedules
Test standards	Confirmation to perform tests as per specified standard. Where no specific Standards exists, provision of full details of proposed test methods, pass/fail criteria and guarantees.
Commissioning tests and schedule	Provide list of proposed commissioning tests and testing schedule

2.9 Other Considerations

Utility Specification Requirements	Manufacturer Supplied Information
Loss evaluation criteria	Losses over a range of operating conditions and the method of loss calculation Loss distribution between the major components Diagrams showing losses versus operating conditions Device models for loss evaluation studies
Tender assessment criteria	Key areas affecting life cycle cost, parameters of the design, which are cost sensitive
Special premiums applied, e.g., for performance in excess of the minimum requirement	Details of the areas where the minimum required performance is exceeded
Health and safety requirements	Health and safety standards, risk assessments, potential hazards in construction and operation and list of any hazardous materials used.
Fire safety requirements	Description of materials used Description of means of protecting against fire Fire containment methods
In service date	Key milestone dates
Decommissioning and disposal method	Provide full data for safe decommissioning, re-usability, recycling or scrapping of components and disposal of potentially hazardous and/or toxic material

All information not marked with an Asterisk (*) is normally provided at the tender stage.

3. EQUIPMENT DESIGN STANDARDS

The following IEC recommendations and other standards are relevant to major components of a VSC Transmission system. In case no similar national standards exist, IEC recommendations can be applied. As this list may not be complete, the investor/utility is advised to determine whether any other standards are applicable in the country of location.

IEC 60070	Power capacitors
IEC 60071-2	Insulation coordination: Application guide
IEC 60076	Power transformers
IEC 60099-4	Metal-oxide surge arresters without gaps for ac systems
IEC 60129	Alternating current disconnects and grounding switches (isolators and earthing switches of rated voltage above 1 kV)
IEC 60146	Semiconductor converters
IEC 147	Essential ratings and characteristics of semiconductor devices and general principles of measuring methods
IEC 60168	Tests on indoor and outdoor post insulators of ceramic material or glass for systems with nominal voltage greater than 1 kV
IEC 60185	Current transformers
IEC 60186	Voltage transformers
IEC 60265	High voltage switches
IEC 60273	Characteristics of indoor and outdoor post insulators and post insulator units for systems with nominal voltages greater than 1000 V
IEC 60517	Gas-insulated, metal enclosed switchgear for rated voltages of 72.5 kV and above
IEC 60694	Common clauses for high voltage switchgear and control gear standards

IEC 60700	Thyristor valves for high voltage direct current (HVDC) power transmission, Part 1: Electrical testing
IEC 801	Electromagnetic compatibility for industrial process measurement and control equipment
IEC 60815	Guide for selection of insulators with respect to polluted conditions
IEC/TR3 60870	Telecontrol equipment and systems
IEC 60871-1	Shunt capacitors for ac power systems having a rated voltage above 1000 V
IEC 60947-3	Low voltage switchgear and control gear – Part 3: Switches, disconnectors, switch-disconnectors and fuse-combination units
IEC 61071-1	Power electronics capacitors – Part 1: General
IEC 60919	Performance of high voltage direct current (HVDC) systems

4 REFERENCE

Draft Specification for a VSC Transmission link as prepared by a manufacturer:

<http://www.abb.com/global/gad/gad02181.nsf/0/023da486583a1cad1256e5c003501be?OpenDocument>

APPENDIX C: OVERVIEW OF LINE COMMUTATED CONVERTER BASED, HVDC

1. INTRODUCTION

Most HVDC schemes in commercial operation today employ line commutated thyristor valve converters. In a line commutated converter, the commutation is carried out by the ac system voltage. This brings inherent difficulty in continuing reliable commutation at very weak ac system voltages, e.g., during ac system faults. An ac system is considered to be very weak if the ratio of [short-circuit power at the point of connection] to the [rating of the HVDC scheme] is less than 2. Some HVDC schemes without dc lines operate successfully with a ratio of less than 1.5. In recent years converter topologies using series capacitors in the HVDC converter have also been utilized to overcome some of these problems. Furthermore, the increase in reactive power consumption with the increase of dc power transferred must be taken into account in the design of the scheme and its control system. The line commutated converter based HVDC (LCC HVDC) will continue to be used for bulk power HVDC transmission over several hundred MW, because this mature technology provides efficient, reliable and cost effective power transmission for many applications.

LCC HVDC was introduced in the USSR in 1950 (Kashira-Moscow) and in Sweden in 1954 (Gotland). Both systems used mercury arc valves. The first application of thyristor valves was to the Eel River scheme in Canada in 1972. The use of thyristors initiated a rapid increase in the installed capacity of HVDC systems because of the superior reliability of thyristor technology. In recent years further reliability improvements and compact designs with large capacity thyristors (up to 8.5 kV, 4 kA) have contributed to the significant progress of HVDC applications.

LCC HVDC has been applied to the following types of power transmission:

- Submarine and underground cable transmission
- Asynchronous link between ac systems
- Long distance bulk power transmission using overhead lines

Its technical capability, combined with its economic advantage and low operating losses, make LCC HVDC a practical solution for enlarging or enhancing power system interconnections.

This appendix provides an overview of LCC HVDC systems, including the general circuit configuration, control schemes, and operational characteristics. A list of LCC HVDC schemes in operation appears at the end of the appendix.

2. SYSTEM CONFIGURATION

HVDC transmission systems can be configured in many ways to suit operational requirements:

- The simplest configuration is the back-to-back interconnection in which two converters are on the same site without a transmission line.
- Monopolar HVDC is a link using a single high-voltage conductor line and the earth (or the sea) or a metallic low-voltage conductor as a return conductor. In recent schemes the use of earth return is becoming less common because of environmental opposition.
- The most common configuration is the bipolar link. Figure C.1 illustrates a simplified single-line diagram of a two-terminal bipolar HVDC transmission system. With a metallic return, the earth grounding is made at only one terminal.

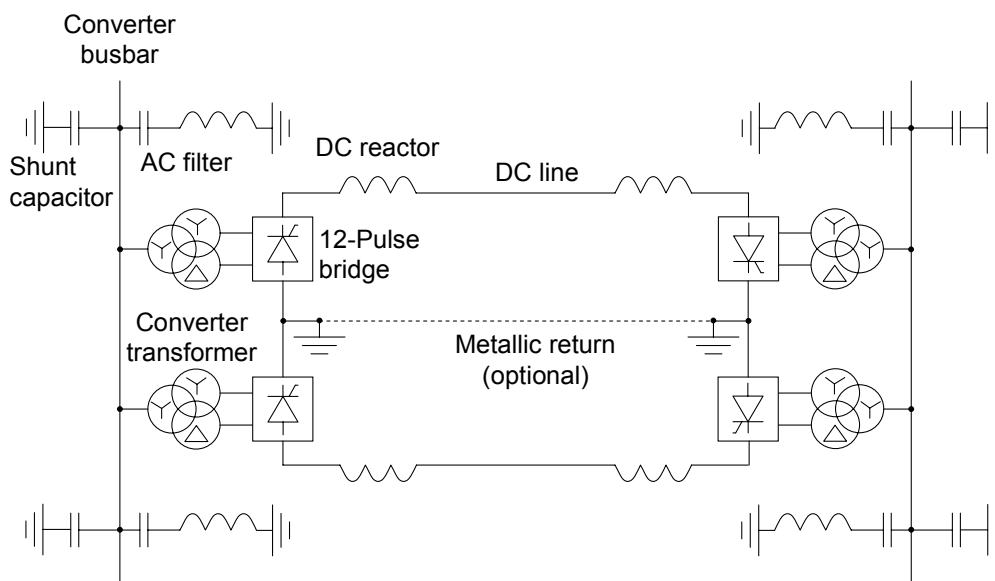

Figure C.1: One-line diagram of a two-terminal HVDC system

A few existing schemes have a multi-terminal configuration in which dc transmission lines connect three or more terminals at different sites. Some LCC HVDC schemes have also been provided with the capability of operating parallel converters at the ends of a dc transmission line.

An LCC HVDC system typically consists of the components discussed in the following paragraphs.

2.1 Converters

The converter performs the energy conversion between ac and dc. It usually has a 12-pulse arrangement, in which two 6-pulse bridges are connected in series on the dc side, as depicted in Figure C.2. The switching of the valves is ordered by the converter control. The rectifier is the converter in which power flows from ac to dc, and the inverter is the converter in which power flows from dc to ac. The principle of conversion and the waveforms associated with these conversions are detailed in references [C-1] and [C-2].

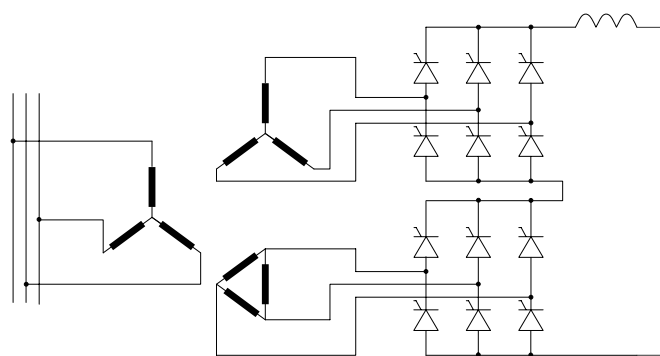

Figure C.2: Configuration of a 12-pulse bridge

2.2 Converter Transformers

The converter transformers adjust the supplied ac voltage to the valve bridges to suit the rated dc voltage. The transformer for a 12-pulse bridge has a star-star-delta three-winding configuration, or a combination of transformers in star-star and star-delta connections. The converter transformers may be provided as single-phase or three-phase units. The converter transformer typically has a leakage reactance of about 10-18% to limit the current during a short-circuit fault of the bridge arm.

2.3 Harmonic Filters

Converter operation generates harmonic currents and voltages on the ac and dc sides, respectively. On the ac side, a converter with a pulse number of p generates characteristic harmonics having the order of $np \pm 1$ ($n=1,2,3,\dots$). AC filters are installed to absorb those harmonic components and to reduce voltage distortion below a required threshold. Tuned filters and high pass filters are used as ac filters. On the dc side, the order of harmonics is np . DC filters, along with dc reactors, reduce the harmonics flowing out into the dc line. DC filters are not required in cable transmission or back-to-back schemes.

2.4 Shunt Capacitors

A line commutated converter in steady-state operation consumes reactive power of about 60% of the active, or dc, power transferred. The shunt capacitors installed at the converter ac bus supply the reactive power required to maintain the converter ac bus voltage. To achieve satisfactory power factor for the LCC HVDC converter, the shunt capacitors are normally subdivided and switched by circuit breakers as the dc power varies. Some or all of the shunt capacitors are normally configured as ac harmonic filters.

2.5 DC Reactors

The dc reactor contributes to the smoothing of the dc current and provides harmonic voltage reduction in the dc line. The dc reactor also contributes to the limitation of the crest current during a short-circuit fault on the dc line. It should be noted that the inductance of the converter transformer also contributes significantly to these functions.

2.6 DC Connections

Cables or overhead lines are always present on the pole connections, except in back-to-back systems. On the electrode connections, many existing systems use the ground return in normal operating conditions (monopolar systems) or in emergency conditions (bipolar systems). However, because of environmental opposition, the utilization of ground return is becoming increasingly problematic and the use of metallic return (as indicated in Figure C.1), although more expensive, is becoming common, especially for monopolar systems.

3. HVDC SYSTEM CONTROL AND OPERATING CHARACTERISTICS

The control system in an LCC HVDC converter station generally has a hierarchical structure with three layers, as illustrated in Figure C.3. From the uppermost, these three layers are referred in this report as bipole control, pole control, and converter unit control. In parallel to the first layer, the station control serves for configuration purposes.

The bipole control coordinates the power orders of the poles and distributes the power order to the pole control. Supplementary controls, such as automatic frequency control (AFC) and power modulation (PM) to improve ac system stability, are also implemented in the bipole control, and these control signals are added to the power order to the pole control. The station control looks after the switching of harmonic filters and shunt capacitors in accordance with operating conditions.

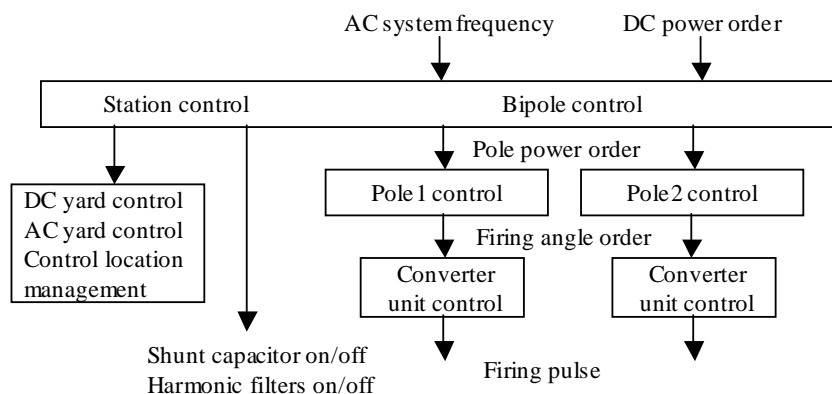

Figure C.3: Schematic configuration of LCC HVDC control system

The pole control shown as an example in Figure C.4 calculates a firing angle order of each converter to follow a power order or a dc voltage order. Finally, the converter unit control arranges firing pulse signals for switching devices, corresponding to the given firing angle order.

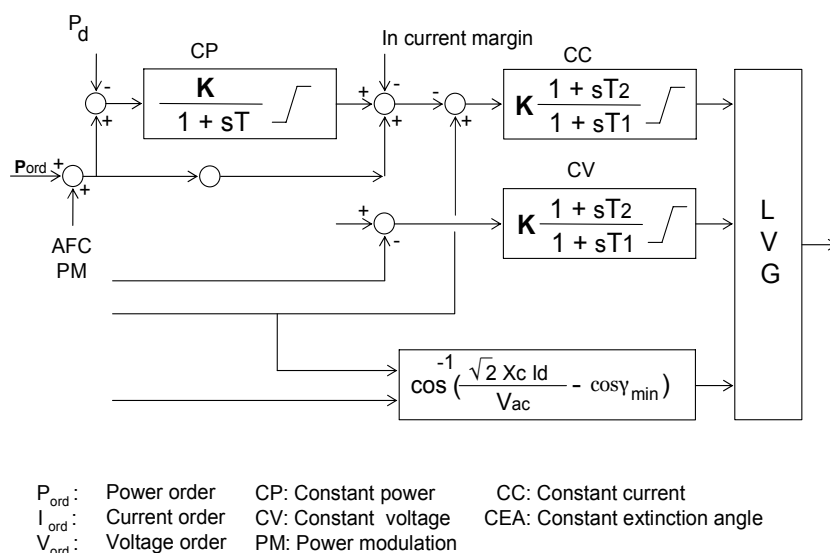

Figure C4: Example of block diagram of a pole control

An LCC HVDC system is usually operated so as to maintain constant dc current and dc voltage. The pole control produces control characteristics, shown in Figure C.5, by selecting the minimum value among the outputs of constant current (CC), constant voltage (CV), and constant extinction angle (CEA) controls, as shown in Figure C.4. Extinction angle control is needed to avoid commutation failures in inverter operation, which occur if the commutation process does not complete a certain time before the thyristor becomes forward biased. In the event of a disturbance in the ac network, e.g., as a consequence of a remote fault, a commutation failure may still occur. The two characteristics of a rectifier and an inverter are symmetrical with respect to the horizontal axis of dc current. The dc current order of the inverter is smaller than that of the rectifier by the current margin, thereby ensuring stable dc current control. The intersection **A** in Figure C.5 indicates an operating point in steady-state condition. Usually, a rectifier sets dc current and an inverter sets dc voltage. The actual operating points of respective converters, however, differ in dc voltage due to the voltage drop of the dc line. Current control is generally required to have a quick response, and voltage control consequently has a comparably slow response to avoid unstable control interaction.

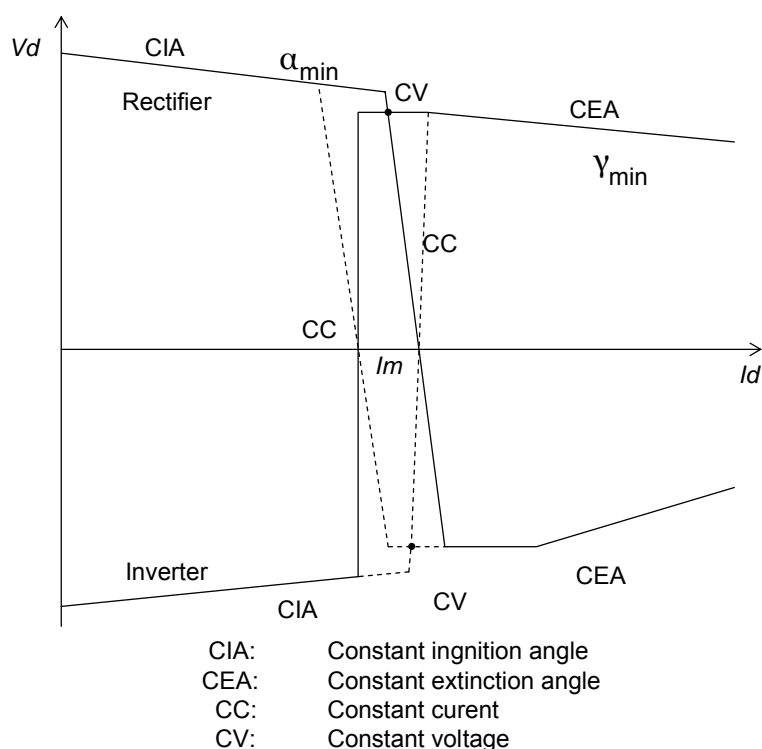

Figure C.5: Converter control characteristics

The setting value of power to be transferred by the HVDC system is ordered from a dispatching center. At any time, only one terminal can control the dc power in a two-terminal system. The converter station that has been assigned the dc power regulation role activates constant power control (CP). This power control is integrated in parallel with dc current control loop and corrects the current order setting so as to adjust actual dc power to the setting value.

Power reversal, or an interchange of the rectifier and inverter operations, can be done by changing the converter that subtracts the current margin indicated in Figure C.4 from the current order setting. A new operating point **B** with reversed dc power is the intersection of the two dotted lines in Figure C.5. In an LCC HVDC system, the power reversal action changes dc voltage polarity and the dc current direction remains the same as before.

4. LIST OF LCC HVDC SCHEMES

Table C.1 provides information about major LCC HVDC schemes in service by the end of 2003. Figure C.6 shows the location of LCC HVDC schemes in the world.

Table C.1: List of major LCC HVDC schemes in service by 2003

System	Year Commissioned	Valve* ¹	Rated Capacity [MW]	Rated DC Voltage [kV]	Transmission Distance (Cable) [km]	Application* ²	
Acaray	1981	T	55	25	0	Intertie, FC	
Baltic Cable	1994	T	600	450	262 (250)	Intertie	
Blackwater	1985	T	200	57	0	Intertie	
Brazil-Argentina	1998	T	1000			Intertie, FC	
Broken Hill	1986	T	40		0	Intertie	
Cahora Bassa	1977/79	T	1920	±533	1420	Generation	
Chandrapur-Padge	1998	T	1500	±500	752	Generation	
Chandrapur-Ramgundam	1997	T	1000	205	0	Intertie	
Chateauguay	1984	T	1000	140	0	Intertie	
Cheju Island	1993	T	300	±180	(101)	Load	
Cross Channel	1	1985/86	T	1000	±270	(70)	Intertie
	2	1986	T	1000	±270	(70)	
CU-project	1979	T	1000	±400	710	Generation	
DA Hamil	1977	T	100	50	0	Intertie	
(Durnrohr) ^{*3}	1983	T	550	145	0	Intertie	
East South Interconnector	2003	T	2000	±500	1450	Generation	
Eddy County	1983	T	200	82	0	Intertie	
Eel River	1972	T	320	80	0	Intertie	
(Etzenricht) ^{*3}	1993	T	600	160	0	Intertie	
Fenno-skan	1989(98)	T	500(572)	400	233 (200)	Intertie	
Gezhouba-Shanghai	1989/90	T	1200	±500	1046	Generation	
Gotland II & III	1983/87	T	260	±150	(98)	Load	
Highgate	1985	T	200	57	0	Intertie	
Hokkaido-Honshu	1979/80/93	T	600	±250	168 (44)	Intertie	
Inga-Shaba	1982	T	560	±500	1700	Generation	
Intermountain	1986	T	1920	±500	785	Generation	
Itaipu	BP1	1985/86	T	3150	±600	South route 807	Generation
	BP2	1989	T	3150	±600	North route 818	
Italy-Greece	2000	T	500	400	310 (200)	Intertie	
Kii channel	2000	T	1400	±250	102 (51)	Generation	
Kontek	1998	T	600	400	(170)	Intertie	
Konti-Skan	1	1965/2005	T	250	+250	180 (85)	Intertie
	2	1988	T	300	-285	150 (87)	
Leyte-Luzon	1998	T	440	350	455 (23)	Intertie	
Madawaska	1985	T	350	140	0	Intertie	
McNeill	1989	T	150	42	0	Intertie	
Miles City	1985	T	200	82	0	Intertie	
Minami-Fukumitsu	1999	T	300	125	0	Intertie	
Moyle	2001	T	500	250	(63)	Intertie	
Nelson River	BP1 P1	1973/93	T	3420	+450	895	Generation
	BP1 P2	1973/77/2005	T		-450		
	BP2	1978/85	T		±500	937	
New Zealand	Pole 1	1965/92	M	1240	+270/	617 (42)	Intertie
	Pole 2	1992	T		-350		
Oklaunion	1984	T	200	82	0	Intertie	
Pacific Intertie	1970/85/2004	T	2000	±500	1361	Intertie	
	1989	T	1100				

Table C.1: List of major LCC HVDC schemes in service by 2003 (Continued)

System	Year Commissioned	Valve* ¹	Rated Capacity [MW]	Rated DC Voltage [kV]	Transmission Distance (Cable) [km]	Application* ²
Quebec-New England	1986/92	T	2690	±450	1486	Generation, Multiterminal
Rihand-Dadri	1991	T	1500	±500	814	Generation
Rivera	2001	T	72.5	22	0	Intertie, FC
Sakuma	1965/93	T	300	125	0	Intertie, FC
Sardinia-Italy (Corsica tapping)	1992	T	300/300/50	200	385 (121)	Intertie, Multiterminal
Sasaram	2002	T	500	205	0	Intertie
Shin-Shinano	1	1977	300	125	0	Intertie, FC
	2	1992	300	125		
Virginia Smith	1988	T	200	55.5	0	Intertie
Sileru Barsoor	1989	T	200	200	196	Intertie
Skagerrak	1, 2	1976/77	940	250	240 (127)	Intertie
	3	1993		350		
Square Butte	1977	T	500	±250	749	Generation
SwePol	1999	T	600	450	230	Intertie
Thailand Malaysia	2001	T	300	300	110	Intertie
Three Gorges-Ghuangzhou	2003	T	3000	±500	1000	Generation
Tian-Guang	2000	T	1800	±500	903	Intertie
Urugaiana	1995	T	50	17.9	0	Intertie, FC
Vancouver	Pole 1	1968/69	312	+260	74 (33)	Load
	Pole 2	1977/79	370	-280		
Visakhapatnam	1998	T	500	205	0	Intertie
Vindhyachal	1989	T	500	70	0	Intertie
Volgograd-Donbass	1962/65	M	720	±400	470	Intertie
	1974/77	T				
Vyborg	1981,84/2000	T	1400	±85	0	Intertie
Welsh	1995	T	600	170	0	Intertie

*1) T: Thyristor Valve, M: Mercury-Arc Valve

*2) Intertie: AC system interconnection, Generation: Generation transmission, Load: Load feeding, FC: Frequency conversion

*3) Schemes no longer in operation

5. REFERENCES

- [C-1] Kunder, P., *Power System Stability and Control*. EPRI Power Engineering Series, McGraw-Hill, 1994.
- [C-2] Arrillaga, J., *High Voltage Direct Current Transmission*, 2nd Edition. IEE Power and Energy Series PO 029, 1998.
- [C-3] Chamia, M., "HVDC - A major option for the electricity networks of the 21st Century," IEEE WPM 1999 - Panel Session, The Role of HVDC Transmission in the 21st Century, November 2001.
- [C-4] Christofersen, D.J., Vancers, I., Elahi, H., Bennett, M.G. "A Survey of the Reliability of HVDC Systems Throughout the World During 1997-1998." CIGRÉ Paper No.14-102, 2000.
- [C-5] Vancers, I., Christofersen, D.J., Leirbukt, A., Bennett, M.G., "A Survey of the Reliability of HVDC Systems Throughout the World During 1999-2000." CIGRÉ Paper No.14-101, 2002.

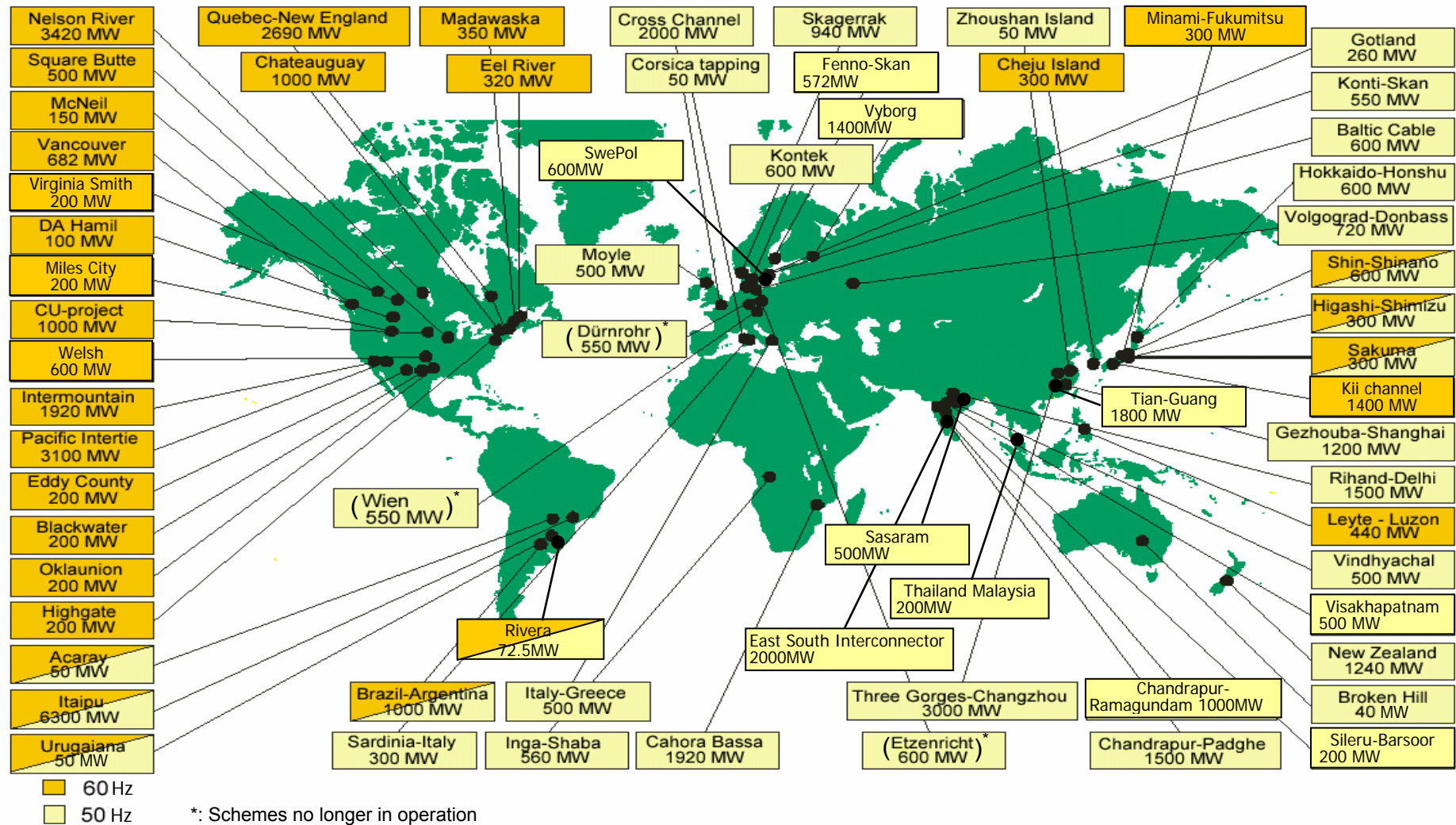

Figure C.6: LCC HVDC schemes in the world (2003)