

263

**CONTROLLED SWITCHING OF
HVAC CIRCUIT BREAKERS
GUIDANCE FOR FURTHER APPLICATIONS
INCLUDING UNLOADED TRANSFORMER
SWITCHING, LOAD AND FAULT INTERRUPTIC
AND CIRCUIT-BREAKER UPRATING**

**Working Group
A3.07**

December 2004



CONTROLLED SWITCHING OF HVAC CIRCUIT-BREAKERS

GUIDANCE FOR FURTHER APPLICATIONS INCLUDING UNLOADED TRANSFORMER SWITCHING, LOAD AND FAULT INTERRUPTION AND CIRCUIT-BREAKER UPDATING

CIGRÉ Working Group A3.07

Members:

**M. Waldron (Convenor), B. Avent, M. Blundell, J. Brunke, D. Carreau,
Y. Filion, P.C. Fernandez, K. Fröhlich, V. Hermosillo, H. Ito, P. Jonsson,
U. Krüsi, F. Martin, J. Martin, A. Mercier, J. Muñoz Florez, J. Patel,
M. Stanek (secretary), K. Suzuki, C. Wallner, E. Portales (guest)**

Copyright © 2004

"Ownership of a CIGRE publication, whether in paper form or on electronic support only infers right of use for personal purposes. Are prohibited, except if explicitly agreed by CIGRE, total or partial reproduction of the publication for use other than personal and transfer to a third party; hence circulation on any intranet or other company network is forbidden".

Disclaimer notice

"CIGRE gives no warranty or assurance about the contents of this publication, nor does it accept any responsibility, as to the accuracy or exhaustiveness of the information. All implied warranties and conditions excluded to the maximum extent permitted by law".

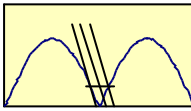

1	Introduction.....	5
2	Controlled Switching of Unloaded Transformers	6
2.1	Background.....	6
2.2	Summary of theoretical principles.....	6
2.2.1	Basic theory.....	6
2.2.2	Controlled Energisation of Multiphase Transformers with No Residual Flux.....	9
2.2.3	Strategies for Controlled Energisation of Three-Phase Transformers with Residual Flux.....	10
2.2.4	Magnetic flux measurement	13
2.2.5	Influence of residual flux on target voltage.....	15
2.2.6	Stability of Residual Flux.....	16
2.2.7	Voltage and Mechanical Scatter Considerations	21
2.2.8	Comparisons of controlled switching with other switching methods	21
2.3	Practical Methodologies for Controlled Energising of Unloaded Transformers.....	23
2.3.1	General.....	23
2.3.2	Energising at a Fixed Target Without Consideration of Residual conditions.....	24
2.3.3	Energising on the basis of measured residual flux	24
2.3.4	Energisation on the basis of planned de-energisation.....	24
2.4	Conclusions	27
3	Controlled short circuit and load interruption.....	27
3.1	Theoretical reduction of interrupter wear by controlled switching.....	27
3.2	Controlled Fault Interruption - Practical Considerations	28
3.3	Rapid Evaluation of Fault Condition.....	29
3.3.1	Determination of fault type	29
3.3.2	Determination of the tripping moment.....	30
3.4	Controlled load interruption.....	30
3.5	Conclusion.....	30
4	Uprating of circuit-breakers	31
4.1.1	Capacitive current interruption.....	31
4.1.2	Short-circuit Interruption.....	35
5	Interruption of small inductive currents using circuit-breakers without a re-ignition free window.....	36
5.1	Basic Principles.....	36
5.2	Example.....	37
6	Controlled switching of series compensated transmission lines.	40
6.1	Introduction.....	40
6.2	Characteristics and Operation of Series compensated lines.....	41
6.3	Example of controlled switching of series compensated line	42
6.4	Conclusion.....	47
7	Controlled switching of pre-installed circuit-breakers.....	47
7.1	Background.....	47
7.2	Controlled shunt reactor de-energisation using existing circuit-breakers—an example	47
7.3	Possible procedure to check the suitability of an in-service circuit-breaker for controlled switching	48
7.4	Conclusions	49
8	Controller survey.....	49
9	Overall Conclusions	50
10	References	52

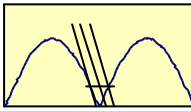

List of figures

Figure 1 :	Optimal energisation of a single-phase transformer.....	7
Figure 2 :	Simulated energisation of the first phase of a three phase transformer.....	7
Figure 3 :	Simulation of a real case transformer energisation using the optimal strategy. System voltage, transformer voltage, and core flux on the 315-kV side	9
Figure 4 :	Simulation of a real case transformer energisation using the optimal strategy.	9
Figure 5 :	Multiphase transformer with single-phase cores and a delta-connected winding	10
Figure 6 :	Energisation of a three-phase transformer without residual flux.	10
Figure 7 :	Prospective and dynamic core flux for a 3-F transformer with residual flux.....	11
Figure 8 :	Laboratory test showing delayed closing strategy on a transformer with a three- legged core and a delta-connected winding.....	13
Figure 9 :	Voltage and flux measurements for 2 real case examples.....	14
Figure 10 :	Typical Flux vs current characteristic	15
Figure 11 :	Influence of the residual flux on target voltage.....	16
Figure 12 :	Double-Break 330-kV Circuit Breaker for the Energisation of generator step-up transformer (GSUT) at Power plant	17
Figure 13 :	Variation of residual fluxes as function of grading capacitance	17
Figure 14 :	Recording of the load side secondary voltage of phase R at interruption.....	18
Figure 15 :	Integration of the load side secondary voltage shown in Figure 14.....	19
Figure 16 :	“Micro” hysteresis loop created by the voltage coupled through the voltage grading capacitors across the circuit-breaker.	19
Figure 17 :	Variation of residual fluxes with network disturbances.....	20
Figure 18 :	The combined effects of mechanical timing deviation and pre-strike.	21
Figure 19 :	Energisation of a 465-MVA step- up transformer without pre-insertion resistors (Voltage signals).....	22
Figure 20 :	Energisation of a 465-MVA step- up transformer without pre-insertion resistors (Transformer inrush currents).....	22
Figure 21 :	Energisation of a 315kV transformer from the HV side with controlled switching: Voltages on a 315 kV network	23
Figure 22 :	Energisation of a 315kV transformer from the HV side with controlled switching. Inrush currents	23
Figure 23 :	Typical arrangement suited to controlled transformer energisation on the basis of controlled de-energisation.	24
Figure 24 :	Typical magnetizing curve and corresponding steady state magnetizing current.	25
Figure 25 :	Magnetizing curve at high frequencies. Current chopping at the peak of the current leads to a released energy that is much less compared to that at power frequency return of the current.	26
Figure 26 :	Reduction of the $I^2 \times t_{arc}$ by controlled opening (depending on the fault type)....	28
Figure 27 :	Test arrangement using the synthetic test installation for RRDS determination..	33
Figure 28 :	Test 2: Result of RRDS determination with filling pressure 0.43 MPa(abs) and increased contact speed. CB in new condition.	34
Figure 29 :	Schematic figure showing the pressure build-up at current zero in the compression chamber of a circuit-breaker versus arcing time.	35
Figure 30 :	Chopping overvoltage at reactor de-energising.....	37
Figure 31 :	400 kV line with series compensation arrangement.....	41
Figure 32 :	Simulated waveforms for Case 4.....	46
Figure 33 :	Example of controllers integrated in substation control and protection schemes	55

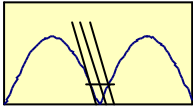

List of tables

Table 1 : Peak Inrush Currents for Case 2 Transformer Using Random Closing	11
Table 2 : Performance Improvement Using Rapid Closing Strategy, 70, 0, -70% Residual Flux (first phase to close has 70% residual flux)	12
Table 3 : Identified switching cases where controlled switching may increase rating.....	36
Table 4 : Calculation of target window for de-energisation of a 50 MVAr reactor	39
Table 5 : Calculation of target window for de-energisation of a 5MVAr reactor	39
Table 6 : Line data of the studied line	43
Table 7 : Switching combinations used for simulation of single-phase fault clearing and re-closing of pure series compensated line.....	44
Table 8 : Results of EMTDC simulations of single-phase to ground faults on series compensated line and followed by three-pole interruption and re-closing.	45

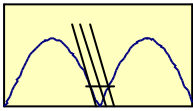

Overview of the work of CIGRE WG 13.07 (A3.07)

CIGRE Working Group 13.07 (subsequently A3.07) was convened in 1996 in order to study, and report upon, the emerging technology of Controlled Switching i.e. the operation of switching devices at a pre-determined point-on-cycle of the power system voltage. The working group was disbanded in 2004 having completed its intended tasks and having produced four major publications.

The first publication of the working group, entitled “*Controlled Switching of HVAC Circuit-breakers – Guide for application*” was published in full, in two parts in ELECTRA No’s 183 and 185. The subsequent three publications have been published as CIGRE Technical Brochures, of which this is one. These are entitled:

- *Controlled Switching of HVAC Circuit-breakers- Planning, Specification & Testing of Controlled switching systems.*
- *Controlled Switching of HVAC Circuit-breakers- Guidance for further applications including unloaded transformer switching, load and fault interruption and circuit-breaker uprating.*
- *Controlled Switching of HVAC Circuit-breakers- Benefits & Economic Aspects.*

The following sections make up the final WG document entitled “*Controlled Switching of HVAC Circuit-breakers- Guidance for further applications including unloaded transformer switching, load and fault interruption and circuit-breaker uprating*”.

1 Introduction

Controlled switching (CS) of HVAC circuit-breakers is already widely applied for applications such as switching of capacitive and small inductive currents. The first two publications of CIGRE WG 13.07 [1] [2] explored the more common cases from a technical perspective and considered the basic requirement such as the influence of the characteristics of the circuit-breaker.

This document is, again, primarily technical and presents complementary information to that in the first publication. The switching cases discussed in this publication are those which are less well developed, those which are the subject of recent developments or those which are, at present, only at the theoretical stage. The main switching cases addressed in this document are unloaded transformers, where significant research has taken place recently, load & fault switching and purely series compensated lines where some speculative gains have been identified. Additionally, the document reports on the possibility and concerns of using CS to uprate circuit-breakers and the possibilities & limitations of retro-fitting CS to pre-installed circuit-breakers. A brief summary of worldwide controller use to date is also included.

For all of the considered switching cases, and dependant upon particular power system and regulatory environment, tangible benefits in terms of lifetime extension, improved system availability or design optimisation can be shown to accrue from the use of CS. These benefits can be very large such as when considering the avoidance of serious temporary overvoltages at transformer energisation or more modest such as reducing the maintenance burden on a frequently switched circuit-breaker. A parallel publication from WG A3.07 [3] attempts to consider the benefits aspects of all controlled switching cases in greater detail.

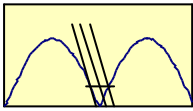

2 Controlled Switching of Unloaded Transformers

2.1 Background

Many industrialised countries have an urgent need to increase the availability and reliability of energy supplies with an ageing electrical infrastructure. Adaptations are required to operate in deregulated, competitive market where switching operations tend to be more frequent. Expansion and re-enforcement of these networks is problematic due to community opposition.

Power transformers are vital components in electrical networks and are the most expensive equipment in substations. They are used in a variety of configurations and for various purposes and they may be switched on an occasional (yearly) or frequent (daily) basis. Random switching of transformers is well known to produce high inrush currents which can reduce their residual life and may also lead protective relay mis-operation and power quality reduction. Controlled switching can be a cost effective solution to these problems in the same way that it is for capacitor bank, a shunt reactor, and line switching. Recent developments have made transformer switching taking into account residual flux a realistic proposition.

Transformer energisation at a non-optimal point on the voltage cycle can create large core flux asymmetries and operation above saturation levels of the core of the transformer. The main cause of this phenomenon is the presence of a residual magnetic flux in the transformer core. This, in turn, may result in high magnitude currents that are rich in harmonic content and have a high direct current component. These currents can cause electrical and mechanical stresses in the transformer and, depending on the prevailing power system conditions, may also cause severe temporary overvoltages (TOV's). In the most severe cases, TOV's may exceed the energy absorption capabilities of surge arresters and expose the equipment in the substation to overvoltages exceeding their withstand levels. Severe TOV's and high inrush currents may also lead to false operation of protective relays and fuses resulting in a general degradation in power quality. Controlled energisation can, in many cases, provide an effective means of mitigating these problems.

2.2 Summary of theoretical principles

2.2.1 Basic theory

Transformer de-energisation results in a permanent magnetisation of the core due to hysteresis of the magnetic material. This value of core flux is known as the residual flux. Upon energisation of a transformer with a residual flux, the offset of the sinusoidal flux generated by the applied voltage is dependent upon the point on the voltage wave at which the transformer is energised. The peak core flux Φ can reach a value of $2\Phi_{normal} + \Phi_{residual}$, or near 3 times normal peak core flux.

It is well known that the optimal closing instant for shunt capacitors is at the instant when the source voltage is equal to the voltage on the capacitor. For the case of controlled closing of transformers the “trapped charge” is analogous to the residual flux and, for optimum energisation, the “induced” flux at the instant of energisation must equal the residual flux [4][5][6]. Whilst there is no induced flux prior to energisation the source voltage has the prospect to create an induced flux. If the source voltage is considered as a virtual flux source, then the optimal instant to energise a transformer is when the “prospective” flux is equal to the residual flux. This principle is shown in Figure 1. It demonstrates the basic strategy for

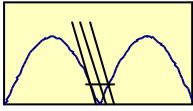

controlled closing of single phase transformers. Optimal energisation points exist at time (1) and at alternate time (2).

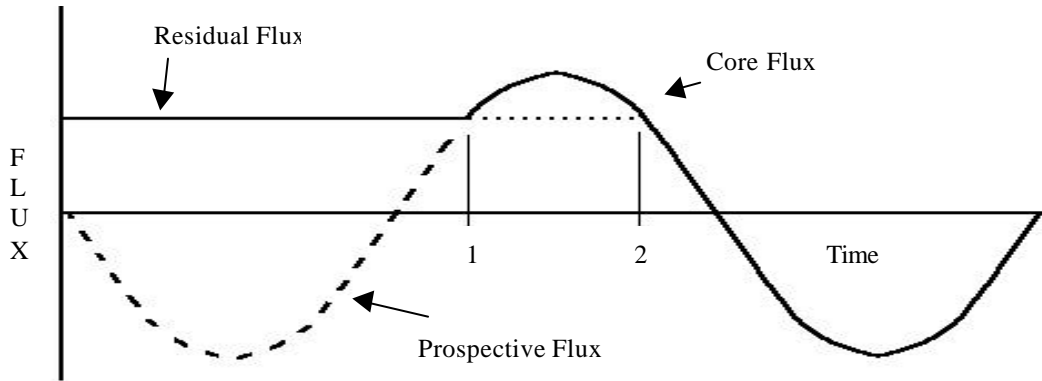

Figure 1. Optimal energisation of a single-phase transformer.

The simulation results shown in Figure 2. demonstrate the effect of the energising instant on the magnetic flux for a three phase transformer energised from an inductive and strong source. In this simulation energisation at instant **P-W** leads to a magnetic flux of 2.77 p.u. as shown by the red curve. Such flux levels will deeply saturate most normal transformers. Theoretically, energising at P-W may result in flux values up to 2.8 p.u. however this does not occur in this simulation because the flux is affected by the waveform and magnitude of energisation overvoltages. Conversely energisation at points P-A or P-B permits the flux to be limited to 1p.u. as shown by the green and black curves.

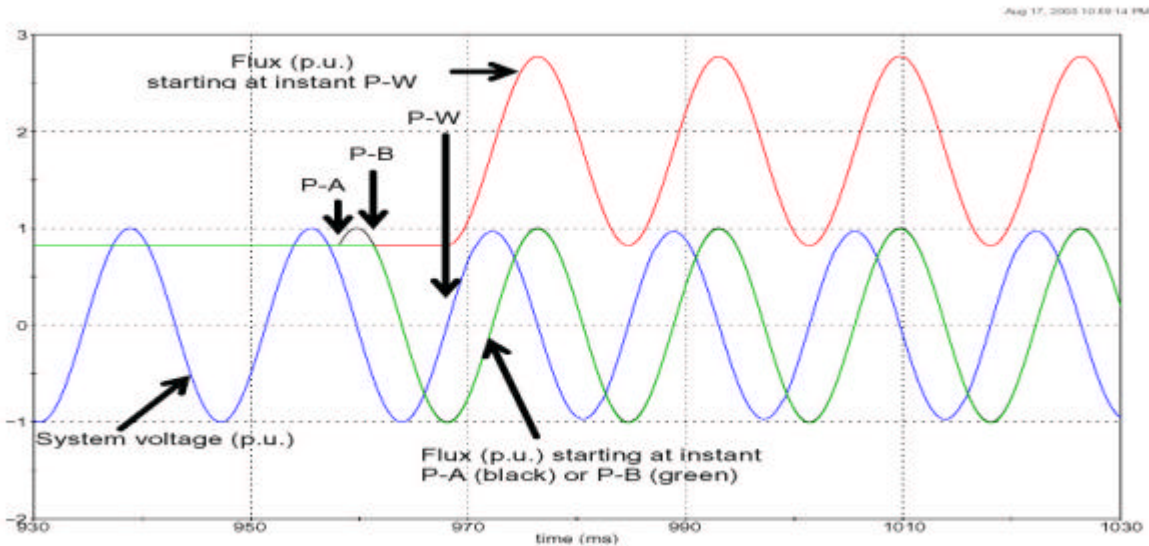
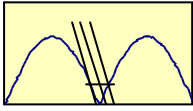

Figure 2. Simulated energisation of the first phase of a three phase transformer

Figure 2. shows that, for a given residual flux, there are two ideal instants for energising the first phase. Energising at instant **P-A** or **P-B** will eliminate inrush currents by allowing the magnetic flux to be fully symmetrical. As discussed in a previous document [1] it is easier to achieve good accuracy when closing onto an increasing voltage slope than when closing onto a decreasing one. On this basis the instant at an angle α after voltage zero crossing will give the best results because it will reduce the circuit-breaker's pre-strike scatter.



The algorithm given below has been derived from the simulation results and offers a very good energising strategy for the three phases. The first closing instant is set on the point on the wave when the instantaneous voltage v is equal to:

$$v = V * \left(\frac{\sqrt{2}}{\sqrt{3}} \right) * \sin (\) \quad (1)$$

The phase with the highest residual flux is energised first with the amplitude and polarity of the residual flux determining the value of the angle α on that phase as follows:

$$\alpha = \arccos \left(\left| \frac{f_r * \left(\frac{\sqrt{3}}{V * \sqrt{2}} \right)}{1} \right| \right) \quad (2)$$

V is the RMS line-to-line voltage in Volts, f_r the residual flux in Weber and $\omega = 2\pi f$.

The optimal closing instant will also depend on the polarity of the residual flux. For a positive residual flux, the instant of closing should be on the negative polarity of the voltage, at angle α after the zero crossing, on the negative slope of the voltage. The converse is true for a negative residual flux.

This algorithm was applied to a simulation with the following initial flux: $f_{rA} = 0.08$ p.u., $f_{rB} = -0.45$ p.u. and $f_{rC} = 0.37$ p.u. The circuit-breaker poles were considered to close simultaneously and the optimum target point was identified on the basis of the phase with the highest residual flux, phase B. Figure 3. and Figure 4. show the simulation results which correspond to the real energising case (see 1.1.1). These figures clearly demonstrate that, under ideal conditions voltage and current transients can be virtually eliminated.

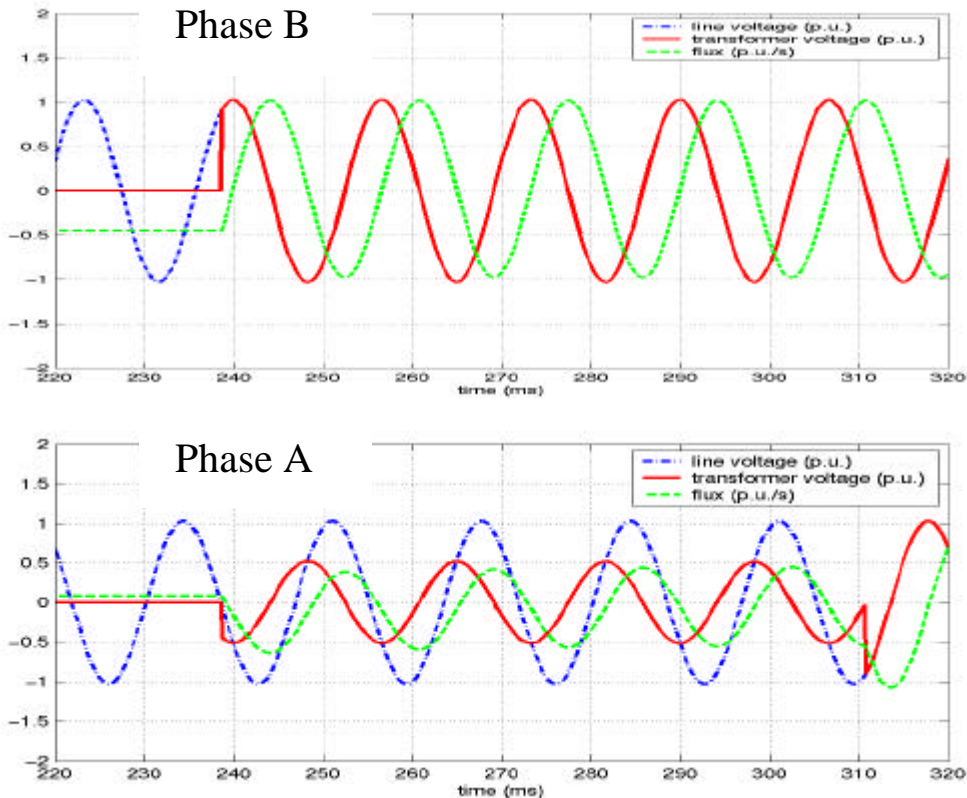

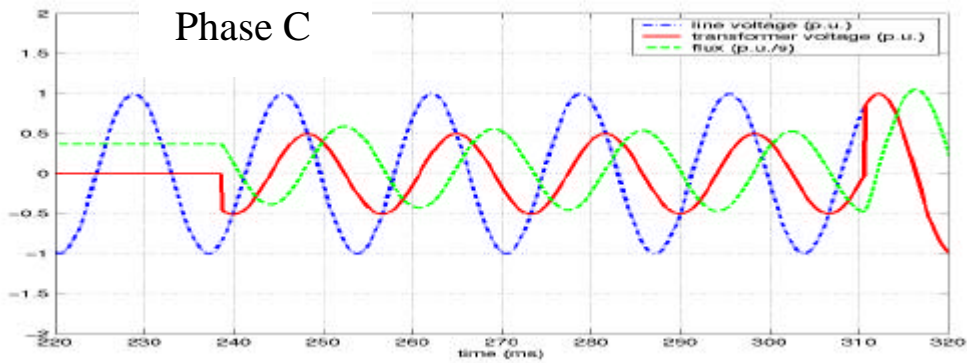
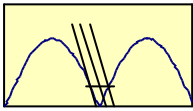

Figure 3. Simulation of a real case transformer energisation using the optimal strategy. System voltage, transformer voltage, and core flux on the 315-kV side

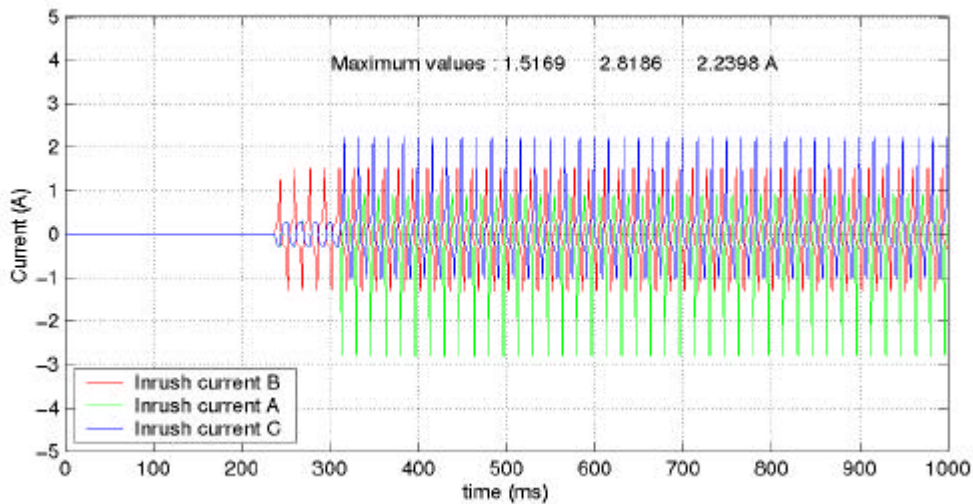
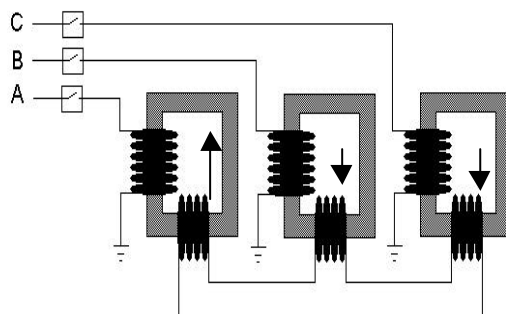
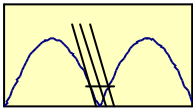

Figure 4. Simulation of a real case transformer energisation using the optimal strategy.

2.2.2 Controlled Energisation of Multiphase Transformers with No Residual Flux

Multiphase transformers with single-phase cores and grounded windings may be considered as groups of single phase transformers. However, many transformers in power systems are not of this configuration and the interactions between the phases must be considered. In these cases energisation of the first phase results in a transient flux in the other cores or core legs. This transient flux is termed the “dynamic” core flux. Oshows an example of a transformer with three separate cores connected by a delta winding. In this example phase A is already energised whilst phases B & C are yet to be energised. The core fluxes in the three phases are indicated by the arrows. Figure 6. shows the prospective and dynamic core fluxes for zero





residual flux in all phases and one phase being energised at its optimal point (prospective flux zero). As proposed already in [7] the optimal point of energisation of the other phases is a quarter of a cycle later as indicated in Figure 6.

Figure 5. A multiphase transformer with single-phase cores and a delta-connected winding

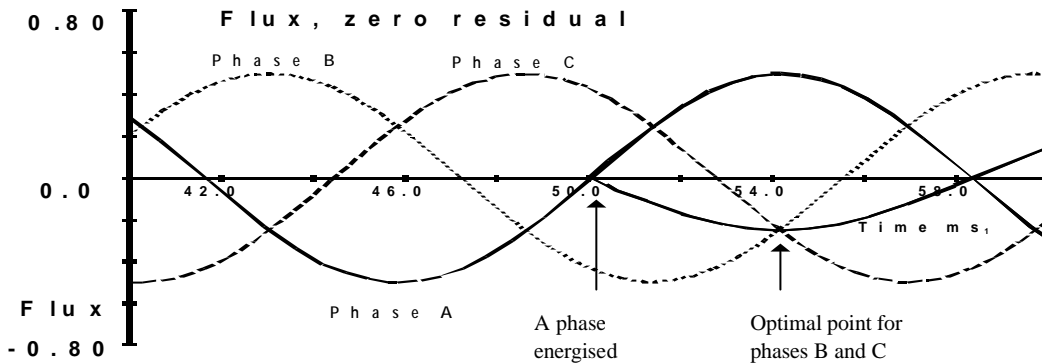

Figure 6. Energisation of a three-phase transformer without residual flux.

This case also represents the optimal energisation of a transformer with a three-phase core where the flux generated by the energised phase will directly create dynamic fluxes in the other two phases. These dynamic fluxes will have the same characteristics as those induced by a delta winding described above.

2.2.3 Strategies for Controlled Energisation of Three-Phase Transformers with Residual Flux

In three-phase transformers, the flux in the main core legs often sums to zero and the residual flux exhibits a pattern of near zero in one phase, and +/- some value in the other 2 phases[8]. This is true for transformers with a three-legged cores, delta secondary windings or auto-transformers with delta winding. It is not the case for transformers without a delta-connected winding, that are single phase or have five-legged or shell-form cores. If one phase of a transformer in which the fluxes sum to zero is energised such that its core leg does not go into saturation, the flux in that phase is equal to its prospective flux at every instant. Since the prospective fluxes and the core fluxes must sum to zero, the induced dynamic core fluxes must equal their prospective fluxes twice per power frequency cycle [4][5][6]. This is illustrated in Figure 7.

The residual flux is 70%, 0, -70% of maximum normal flux on phases A, B, and C respectively. The first phase (A) is energised at its optimal instant and the optimal instants for closing the other phases are shown. For each phase the optimal instant is defined by the intersection between the dynamic and prospective fluxes.

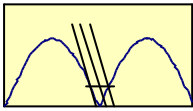

Depending upon the polarities of the residual flux in the second and third legs the dynamic core flux and prospective fluxes will be equal either at the point marked “B” or “C” in Figure 7. These points offer the opportunity to energise the other two phases without saturation of the core. This closing strategy is termed “rapid closing.” Point “B” is more tolerant to closing timing error than point “C” since the slopes of the prospective and dynamic fluxes are nearly equal for a period of approximately a millisecond. This is not the case at point “C”.

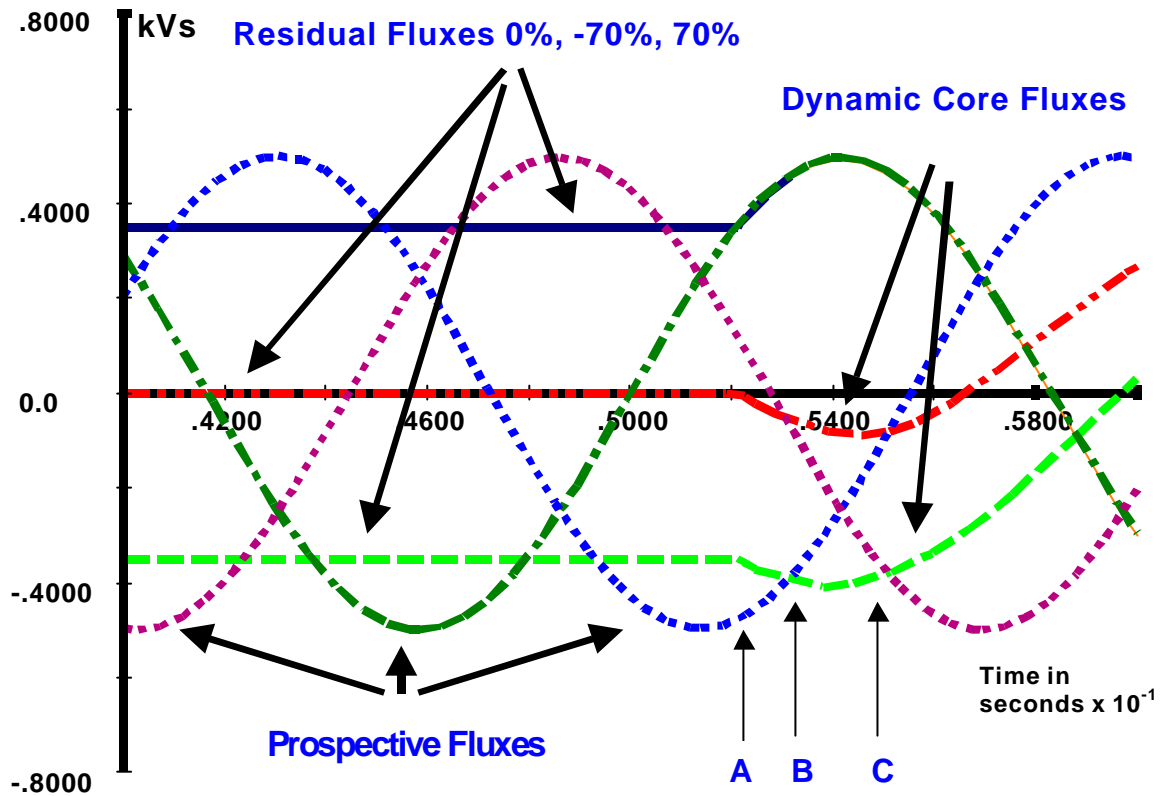
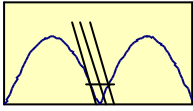

Figure 7. Prospective and dynamic core flux for a 3-F transformer with residual flux.

Table 1. summarises the results of an EMTP study of a flux dependant transformer having a three phase core and delta connected tertiary (termed a “Case 2” transformer). The study was run as a statistical "linear bias" run of 1000 EMTP simulations over one cycle.

Table 1. Peak Inrush Currents for Case 2 Transformer Using Random Closing

Case	Mean (Amps)	2% Current Level (Amps)
3 Phase, Zero Residual on all Phases	1021	1380
3 Phase, 0, 70, -70% Residual	1267	2280
3 Phase, 0, 35, -35 % Residual	1076	1775



Using the previously described rapid closing strategy transient studies provided the following inrush current performance for the same transformer model and a residual flux pattern of +70%, 0, and -70% in the three phases.

Table 2. Performance Improvement Using Rapid Closing Strategy, 70%, 0%, -70% Residual Flux (first phase to close has 70% residual flux)

3 Circuit-breaker Closing Time Scatter (ms)	2% Current (Amps)	Reduction From Random Closing (%)
0.5	45	98.0
1.0	125	94.5
1.5	192	91.6
2.0	320	86.0

Table 2 shows how reduction of the inrush current depends on the closing scatter of the circuit-breaker and that significant reductions in inrush current can be achieved using controlled switching.

Another interesting closing opportunity can also be observed in Figure 7. At point “A”, where the first phase is closed, the dynamic and prospective fluxes of the other two phases are nearly equal and therefore nearly optimal for this residual flux pattern. If the residual fluxes were slightly higher on these two phases, point “A” would be optimal for a simultaneous closing of all three phases. This offers some unique opportunities for lower voltage systems, where independent-pole-control circuit-breakers are uncommon. This is called the “simultaneous” closing strategy.

There are several patterns of the residual flux on each phases such as (0, 0, 0), (A, 0, -A), (-A, 2A, -A), (A, B, -A-B) depending on the stray capacitance in the transformer circuit, the chopping current and the design of the core, etc. As described in a previous section, the simultaneous closing GCB can be applied to minimise an inrush current in case of (A, 0, A) pattern. On the other hand, the independent pole operated (IPO) GCB can be applied to any patterns including the cases shown in Figures 9. Furthermore a controlled de-energisation can control the residual flux to some extent, For example, the delayed closing strategy with IPO provide a more successful reduction of inrush currents[9].

After one phase is energised, the residual flux in the other phases is rapidly eliminated. This means that if one phase is energised when the residual and prospective core fluxes are equal and the closing of the last two phases is delayed a few cycles, residual flux can be ignored on these two phases. This is referred to as the “delayed closing strategy.” This strategy is demonstrated in the test energisation of a laboratory transformer in Figure 8.

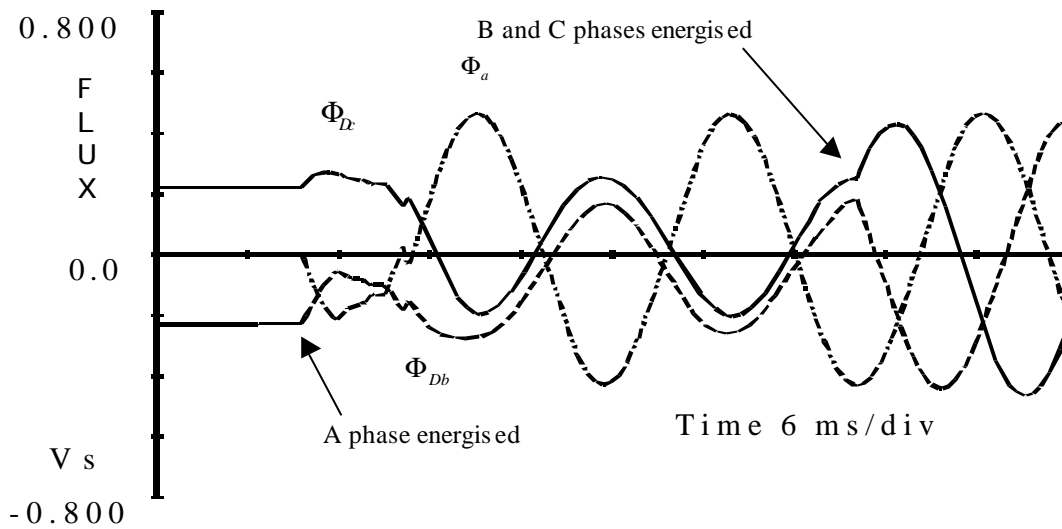
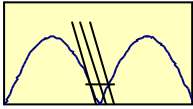

Figure 8. Laboratory test showing delayed closing strategy on a transformer with a three-legged core and a delta-connected winding.

The delayed closing strategy requires a significant circuit-breaker pole spread of several power frequency periods and before using this technique it must be confirmed that the system and the control settings allow for such a large pole spread.

In most three-phase transformers it is possible to use residual flux measurements (see 2.2.4) and controlled closing to eliminate transformer inrush transients. Three strategies have been proposed for controlled energisation of multi-phases transformers. For all three strategies, closing each winding when the prospective and dynamic core fluxes are equal results in an optimal energisation without core saturation or inrush transients.

Each strategy has its own advantages and disadvantages. The rapid closing strategy can provide the most significant reductions in transient reduction but is the most difficult to implement. The delayed strategy is the easiest to implement and can be applied to transformers with more than three core legs, shell form cores and no delta connected winding however it spreads out closing pole span over a few cycles. The simultaneous closing strategy allows ganged three-phase operation but requires high residual flux magnitudes and more sophisticated algorithms to determine the correct closing point.

2.2.4 Magnetic flux measurement

A significant aid to the controlled switching of transformers is knowledge of the residual flux and hence flux measurement is of significant interest. To achieve a measure of the magnetic flux without being intrusive the value has to be derived from a more easily accessible signal such as the voltage at the transformer terminals. The relationship between the magnetic flux “F” of a coil with “N” turns and an applied voltage “E”, is expressed as follows:

$$\Phi = \left(\frac{1}{N} \int E \right) + f_r \quad (3)$$

where f_r is the residual magnetic flux. Measuring and integrating the voltage of each phase just before and during steady state de-energisation of the transformer permits derivation of the

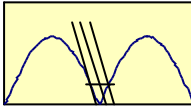

residual flux. This flux is the final value of the integrated voltage. Integration of the voltage signal occurs over a pre-determined time window spanning de-energisation. Only a small number of cycles are used for the integration which minimises the possibility of small offset errors in the voltage measurement leading to large errors in the results.

Figure 9. shows two real case examples in which the system measured the residual flux at de-energisation.

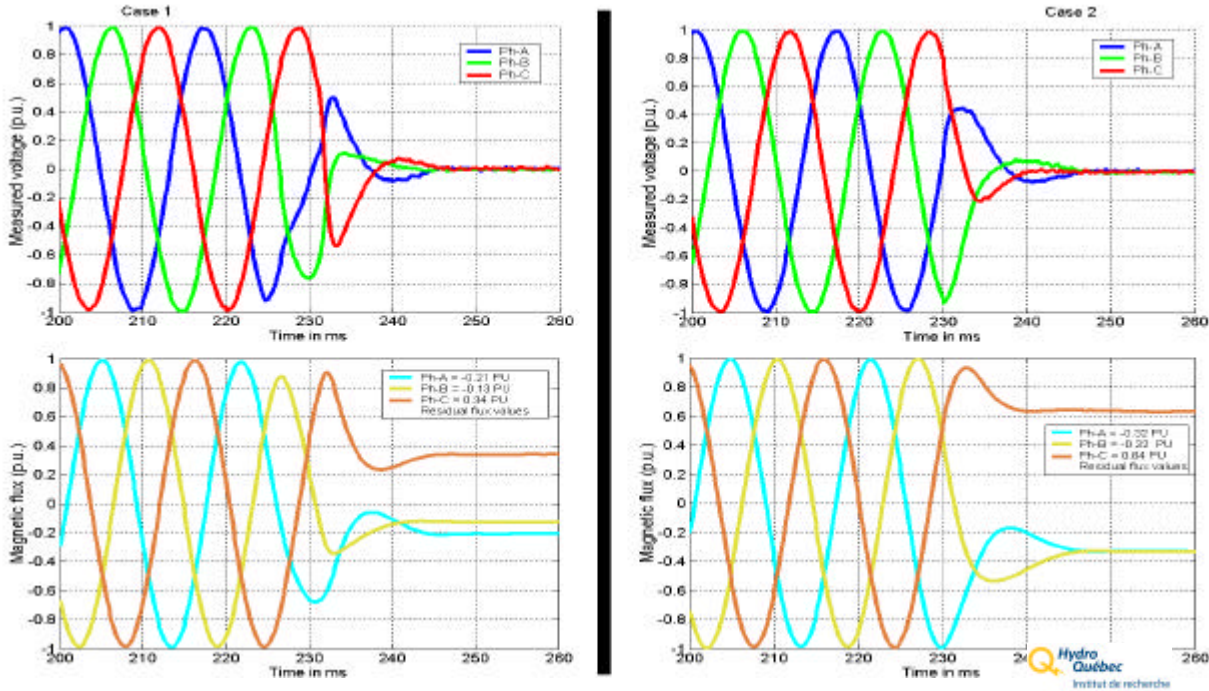

Figure 9. Voltage and flux measurements for 2 real case examples

The core flux attains its final value after the voltage oscillation is sufficiently damped [9][10]. The residual flux (F_r) is given by the difference between the average value of the transient core flux and the final value of the flux. If, during the measurement time the average flux value is not zero then measurement of the transformer input current and the transformer “flux vs current” characteristic are also needed. A typical flux/current characteristic is shown in Figure 10.

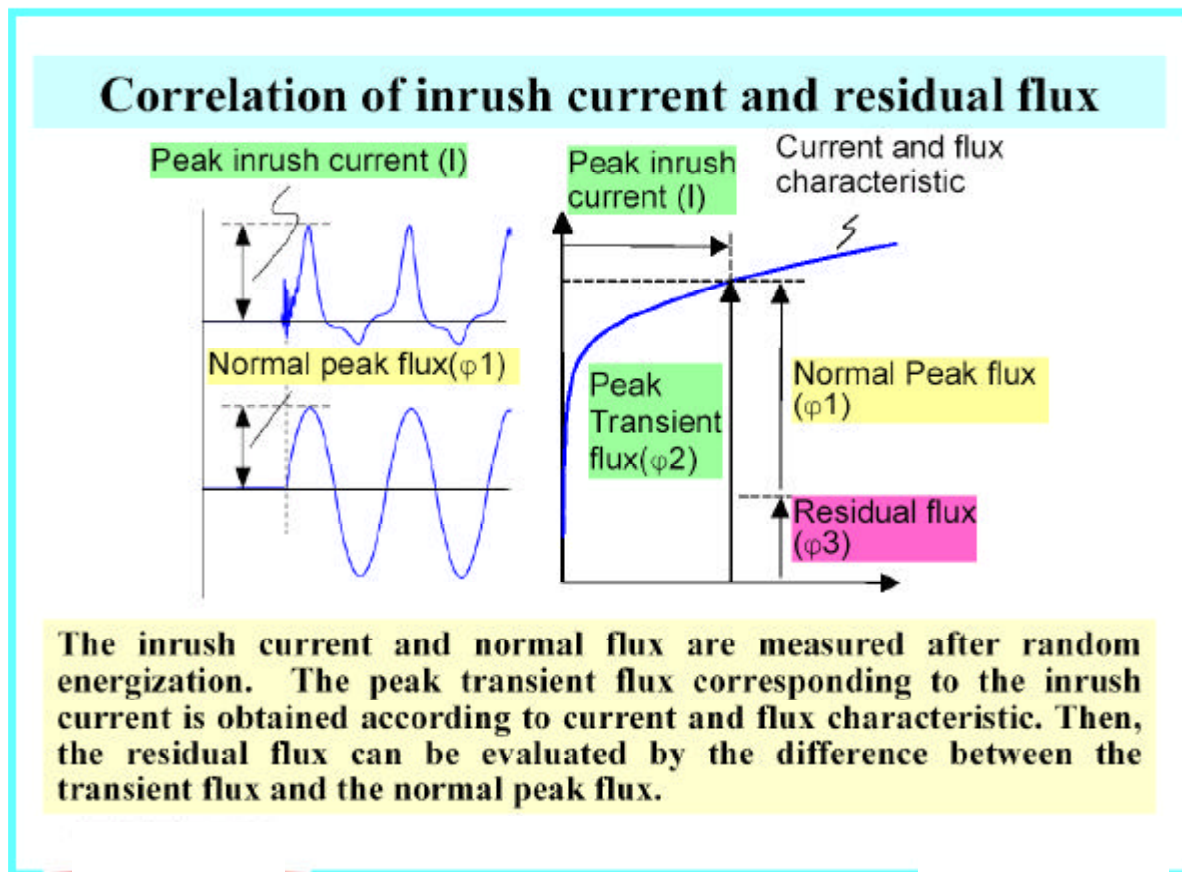
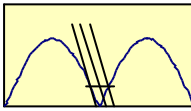

Figure 10. Typical Flux vs current characteristic

2.2.5 Influence of residual flux on target voltage

Conventional controlled energisation of transformers, ignoring residual flux, involved closing at, or close to, voltage peak. This approach tended to generate steep voltage transients particularly in the cases of SF₆ or vacuum circuit-breakers. These transients could be further exacerbated by the local system configuration e.g. transformers using direct GIS connections.

Any consideration of residual flux will move the target voltage away from the peak and hence reduce the amplitude of the steep voltage transient when the circuit-breaker pre-strikes. When considering this effect two basic transformer configurations have to be considered: those where the fluxes in the phases are independent from each other and those where the fluxes are not independent. For independent phases, a reduction of the target voltage can be achieved in all three phases depending on the level of residual flux as given in Figure 11. which has been derived using Equations (1) & (2). However, when the fluxes in the various phases are not independent the reduction shown in Figure 11. can only be achieved in the first phase to close. This is because the optimum switching instant in the other phases is defined by the interaction of the fluxes rather than the residual fluxes.

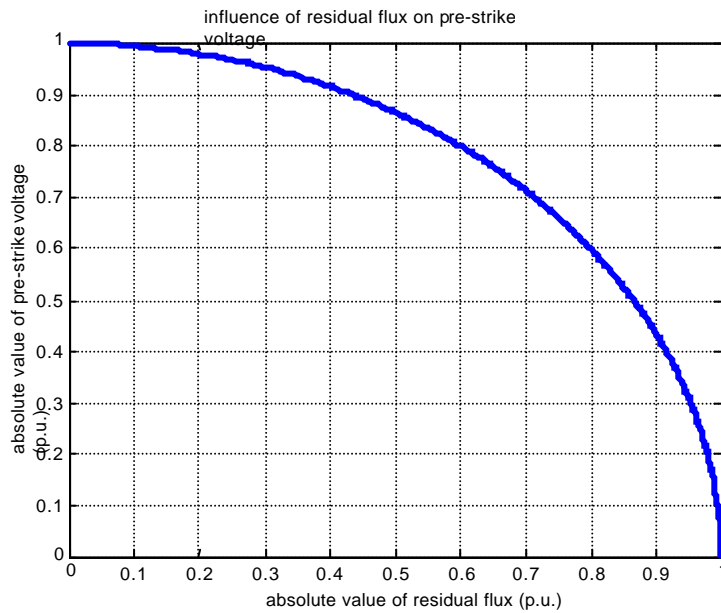
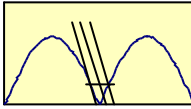

Figure 11. Influence of the residual flux on target voltage.

2.2.6 Stability of Residual Flux

It is widely accepted that residual flux within transformer cores is “locked in” and does not change over time unless there are external influences. Nevertheless, due to the importance of this aspect for controlled transformer energisation, further investigations are being pursued within certain utilities. These results are unavailable at the time of writing.

A phenomenon which has already been reported is the influence of voltage grading capacitors which are fitted across circuit-breaker interrupters for the purpose of equalising the voltage across the breaking units[22].

2.2.6.1 Effect of Grading Capacitors on Residual Flux

The magnitude of residual flux in the transformer and the waveform of system power frequency voltage are the main parameters to determine the optimal instants for transformer energisation. Circuit-breaker voltage grading capacitors have been shown to have a small effect on the residual flux and further complicate controlled energising techniques which rely on flux measurement.

Studies have been carried out for an installation where a generator step up transformer is switched using a 330kV two break circuit-breaker with 1500pF voltage grading capacitors as shown in Figure 12. The grading capacitors together with the stray capacitances of the bus bars and transformer induce a power frequency voltage on the transformer after the opening of the circuit breaker. Studies have been carried over a range of grading capacitor values from 1500 pF to 7500 pF and the results are summarised in Figure 13. These results suggest a tendency for the grading capacitors to decrease the residual flux in the transformer after de-energisation. However, the dc flux components are still predominant.

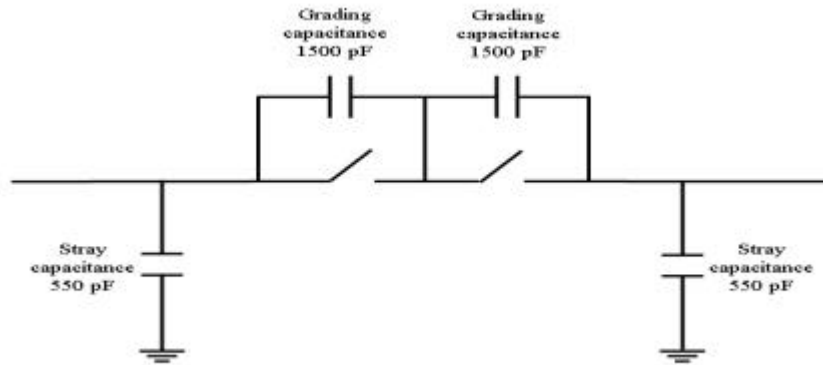
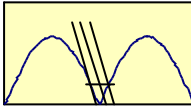

Figure 12. Double-Break 330-kV Circuit Breaker for the Energisation of a generator step-up transformer (GSUT) at a power plant

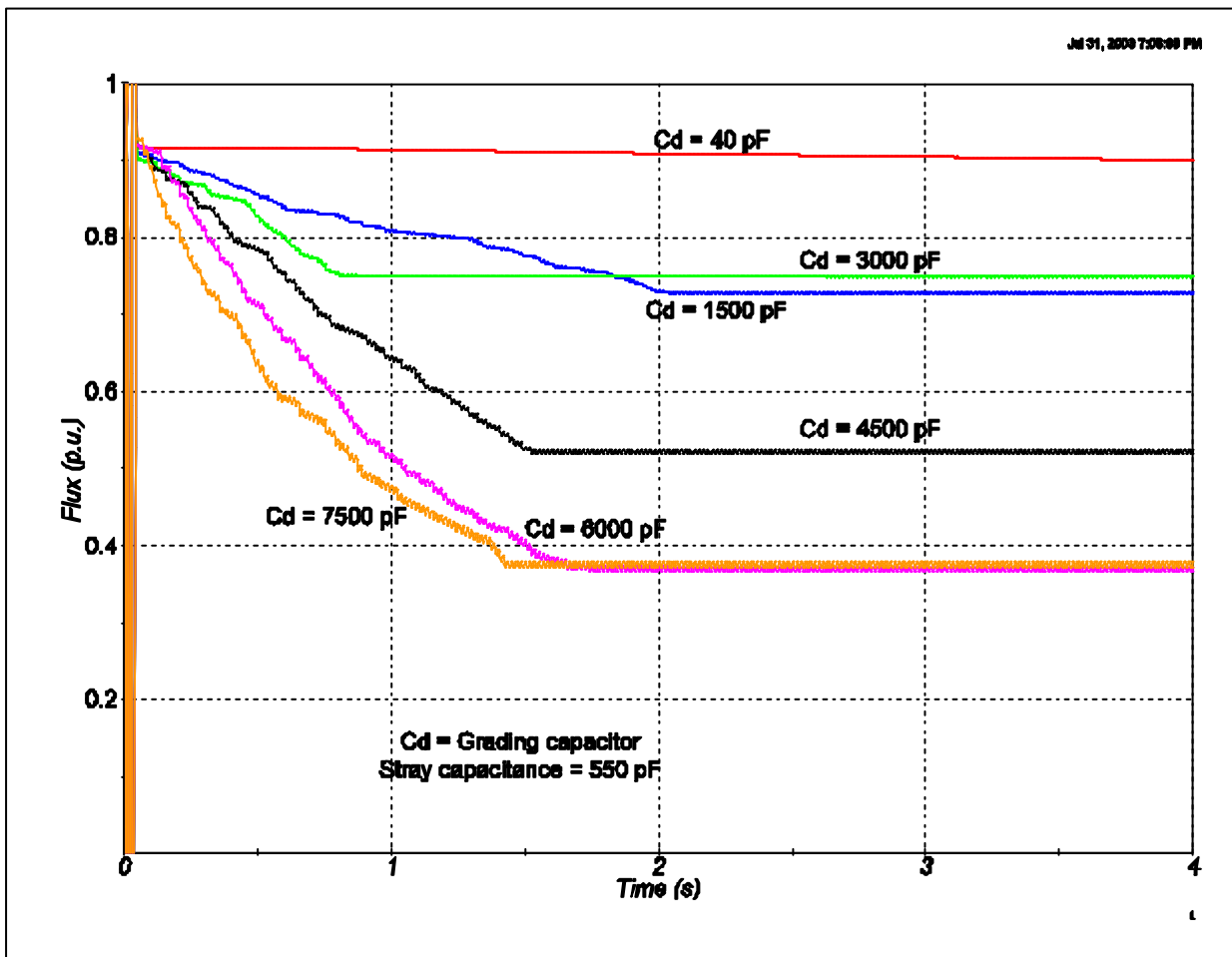

Figure 13. Variation of residual fluxes as function of grading capacitance

Figure 14. shows a system measurement of the secondary load side voltage when de-energising a 420/132 kV, 50 Hz Y-0/y-0 auto transformer with three-limbed iron core and without any tertiary winding. This transformer has a rated power of 750 MVA, $I_n = 1030$ A. The transformer was de-energised under no-load condition from the 420 kV side by a two unit circuit-breaker having voltage grading capacitors 1600 pF (800 pF across the complete pole).

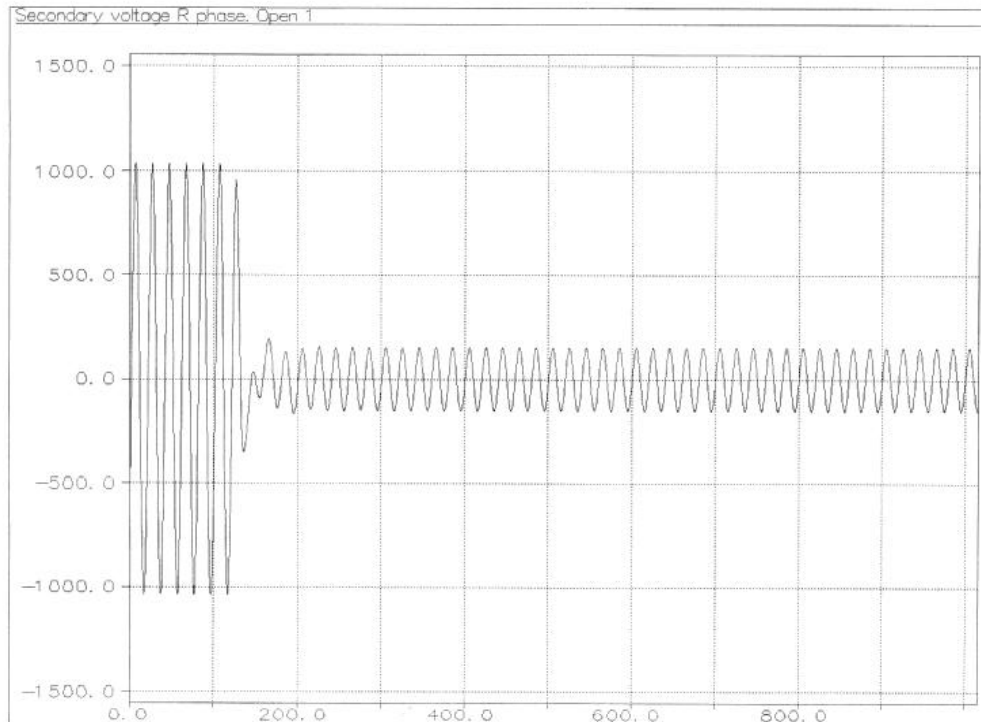
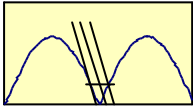

Figure 14. Recording of the load side secondary voltage of phase R at interruption (1600pF per break, 800pF total)

It can be seen that approximately 14% of the supply voltage continued to be coupled through the capacitors after the circuit-breaker was de-energised. In total the de-energised load consisted of the power transformer, 50m of conductors and electromagnetic voltage transformers connected to the transformer secondary bushings.

The residual flux in this case was determined by integration of the load side voltages. The voltage integration is shown in Figure 15.

The figure shows a slight drift in the integrated voltage due to a minor zero line off-set error in the voltage measurement which adds up during the integration. The red line represents the average value of the residual flux determined by the controller.

This effect can be explained as follows. The voltage coupled through the voltage grading capacitors results in an oscillating flux that, in turn, creates a “micro” hysteresis loop. This loop is represented by the blue area in Figure 16. The centre of the “micro” hysteresis loop within the main loop represents the average value of the residual flux shown in Figure 15.

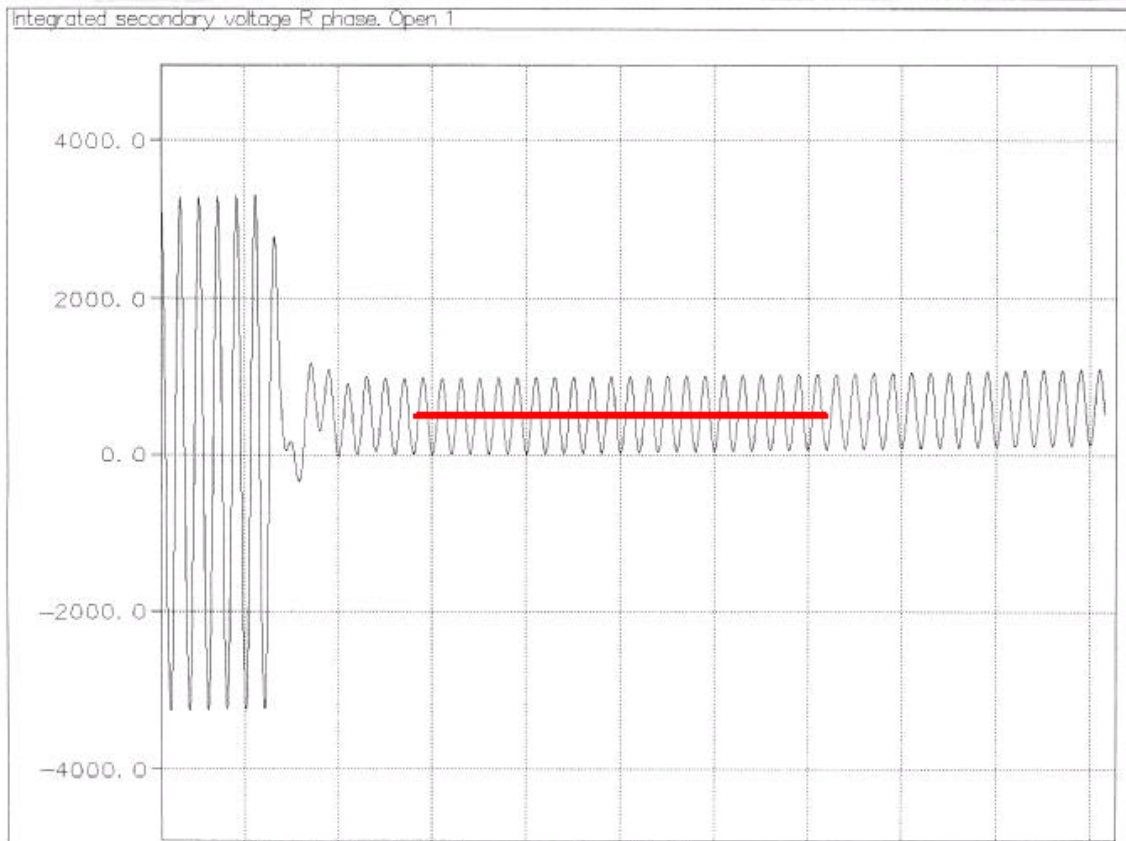
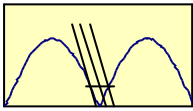

Figure 15. Integration of the load side secondary voltage shown in Figure 14.

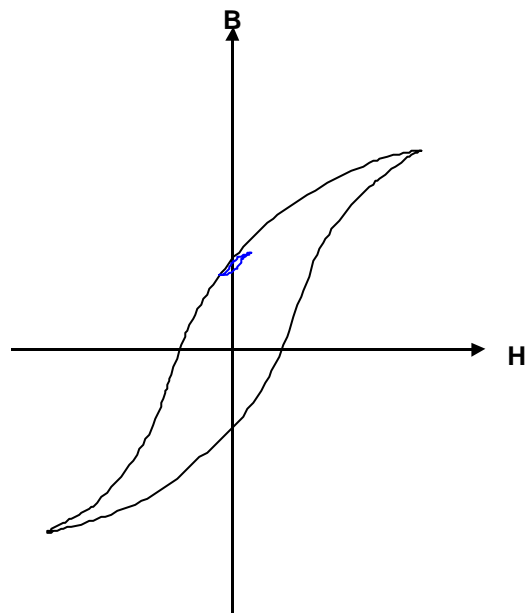

Figure 16. "Micro" hysteresis loop created by the voltage coupled through the voltage grading capacitors across the circuit-breaker.

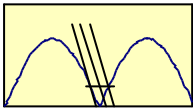

Figure 16. suggests that the effect of the voltage grading capacitors is of small consequence for controlled switching. This is consistent with Figure 13 for lower values of grading capacitance (up to about 3000pF). The magnitude of the “trapped” flux is virtually unaffected by the coupled voltage which merely creates a small hysteresis loop around the trapped values. Field tests using a controller that determines an average value of the residual flux have confirmed the predicted results and have shown no sensitivity to whether the load transformer was fully disconnected or not [18].

By considering an average value of the measured residual flux and using the already discussed algorithm a maximum targeting error (energising instant versus intended energising instant) of 0.48 ms was calculated. This timing error was calculated based on an instant residual flux value at energising having maximum deviation from the measured and calculated mean value. In comparison, by selecting a measured instantaneous value with a maximum deviation from the instant residual flux value at energising (i.e. not considering a mean value) results in a maximum energising instant deviation of about 1.0 ms.

In summary, controlled transformer energising by means of circuit-breaker having parallel voltage grading capacitors, using a strategy based on measured residual flux at interruption may lead to phase shift deviations due to slightly undetermined flux. Target errors, typically of the same order as a normal mechanical scatter, may result. This error can be minimised by determining an average value of the residual flux.

2.2.6.2 Effect of network disturbances on Residual Flux

When the circuit breakers are equipped with grading capacitors any network disturbances have an effect on the residual flux. Simulation results, summarised in Figure 17. , show the variations of residual flux obtained with faults to ground initiated at different instants and cleared after 6 cycles in the systems (fault at 55 km of de-energised transformer). In this case also, the dc flux components are still predominant and the measurement of dc residual fluxes is still necessary to control the optimal instants for transformer energisation.

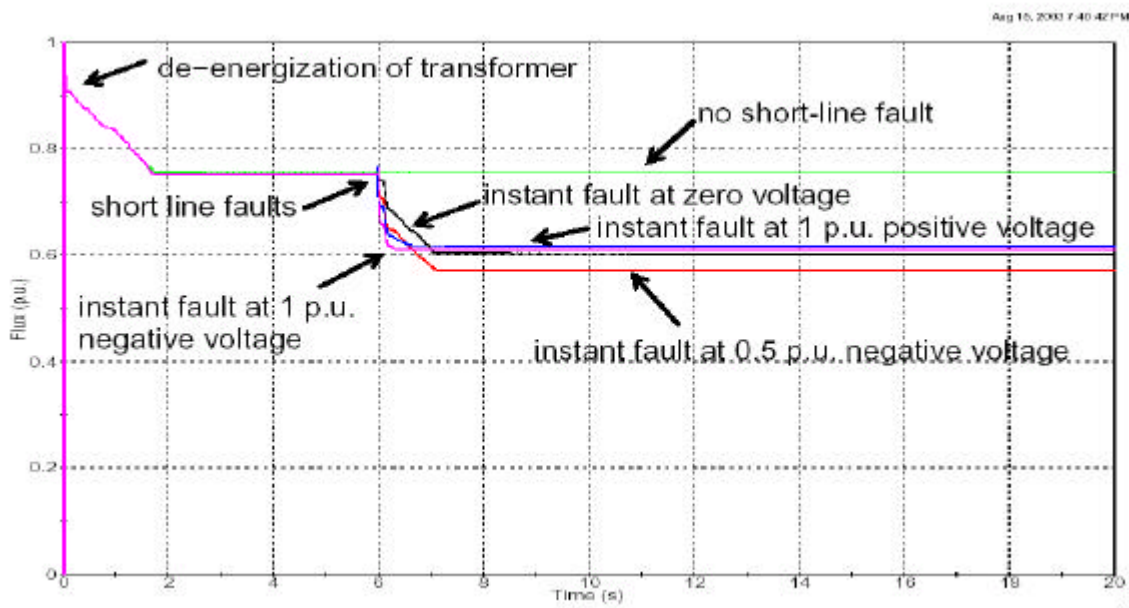
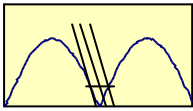

Figure 17. Variation of residual fluxes with network disturbances



2.2.7 Voltage and Mechanical Scatter Considerations

Practical application of controlled switching emphasises the importance of mechanical timing deviation within the circuit-breaker. In the examples above a residual flux pattern of near zero on one-phase and +/- values on the other was used; a pattern which has been observed during modelling and testing. However, for a number of reasons, closing on a phase with a higher residual first is advantageous.

Firstly closing onto a high residual flux (and hence at a lower supply voltage) imposes less voltage stress on the transformer at the instant of energisation. Secondly, it allows closing on the rising voltage wave where impacts of mechanical timing deviations are reduced and statistical performance is increased. This is shown in Figure 18. where for the same circuit-breaker scatter, closing on a rising voltage wave produces the scatter "A" and closing on a falling voltage wave produces the scatter "B".

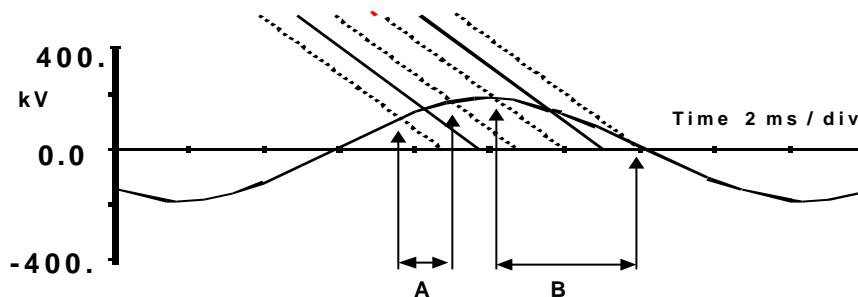

Figure 18. The combined effects of mechanical timing deviation and pre-strike.

For a more detailed description of the RDDS including statistical variations of the slope see reference [1].

If residual flux is assumed to be zero, closing is set for peak voltage and the transformer is always exposed to a high rate of change of voltage. Consideration of the residual flux not only improves performance but also reduces voltage stresses. Using a circuit-breaker of expected timing accuracy significant reductions in inrush current can be achieved [4][5][6]. Typical study results indicate that for a circuit-breaker with a statistical closing time deviation of +/- 1.0 ms a reduction of peak inrush currents of more than 85% can be achieved when compared to the worst-case uncontrolled scenario.

2.2.8 Comparisons of controlled switching with other switching methods

Figure 19. and Figure 20. show temporary over-voltages (TOV's) and the associated inrush currents which were experienced when energising a transformer on a 315kV system without pre-insertion resistors or other palliative measures. The maximum transformer inrush current reaches 2358 A peak. Clearly, phenomena of this type are likely to be detrimental both to network power quality and to the life expectancy of a transformer.

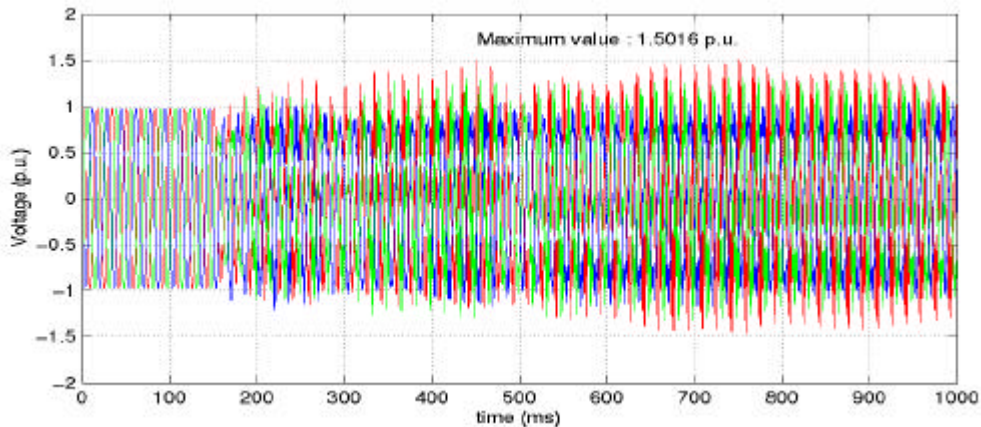
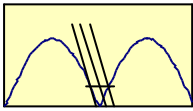

Figure 19. Energisation of a 465-MVA step-up transformer without pre-insertion resistors (Voltage signals)

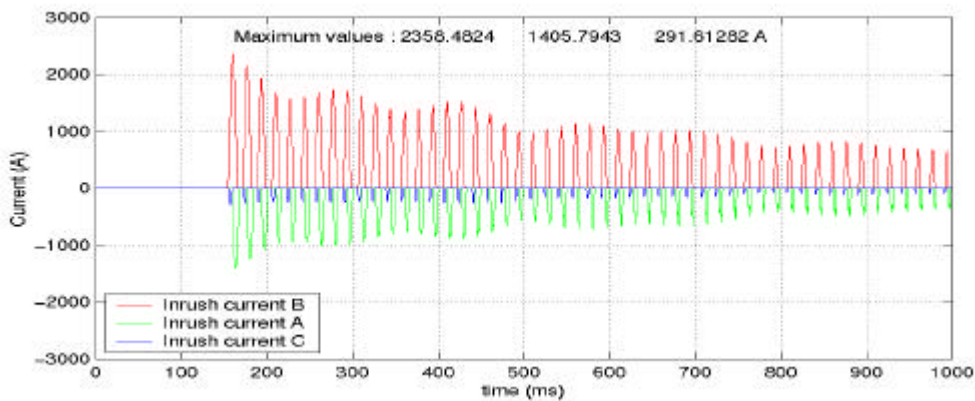

Figure 20. Energisation of a 465-MVA step-up transformer without pre-insertion resistors (Transformer inrush currents)

The conventional solution to this problem is the use of 1000- Ω pre-insertion resistors with an insertion time of 14 ms. Whilst this allows harmonic TOVs to be suppressed and reduces the inrush current in the energised transformer pre-insertion resistors are well known to require significant maintenance over their lifetime.

An alternative solution is the use of a controlled-switching scheme taking into account the residual magnetic flux of the transformer core to determine the appropriate switching instant. Figure 21. and Figure 22. show the simulation results of the deterministic studies of this solution. These show clearly that controlled switching can effectively suppress TOVs and inrush currents during the energisation of the 18/325-kV transformer from the 315-kV side.

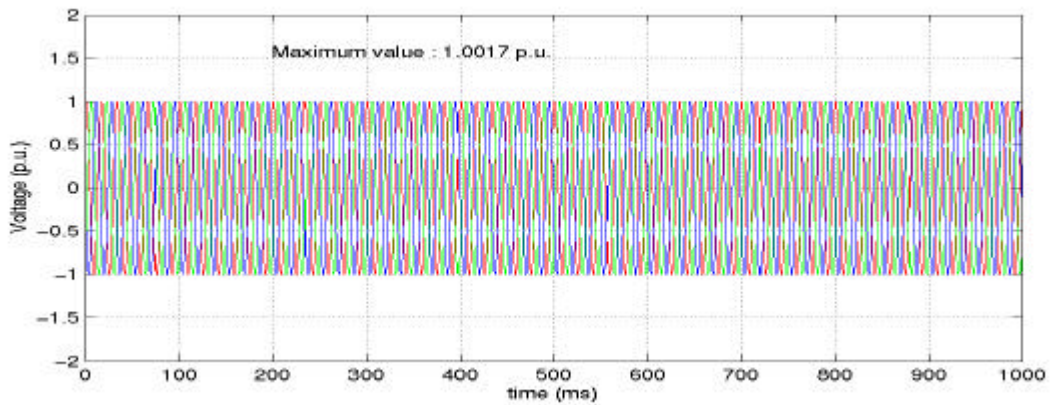
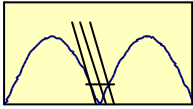

Figure 21. Energisation of a 315kV transformer from the HV side with controlled switching: Voltages on a 315 kV network

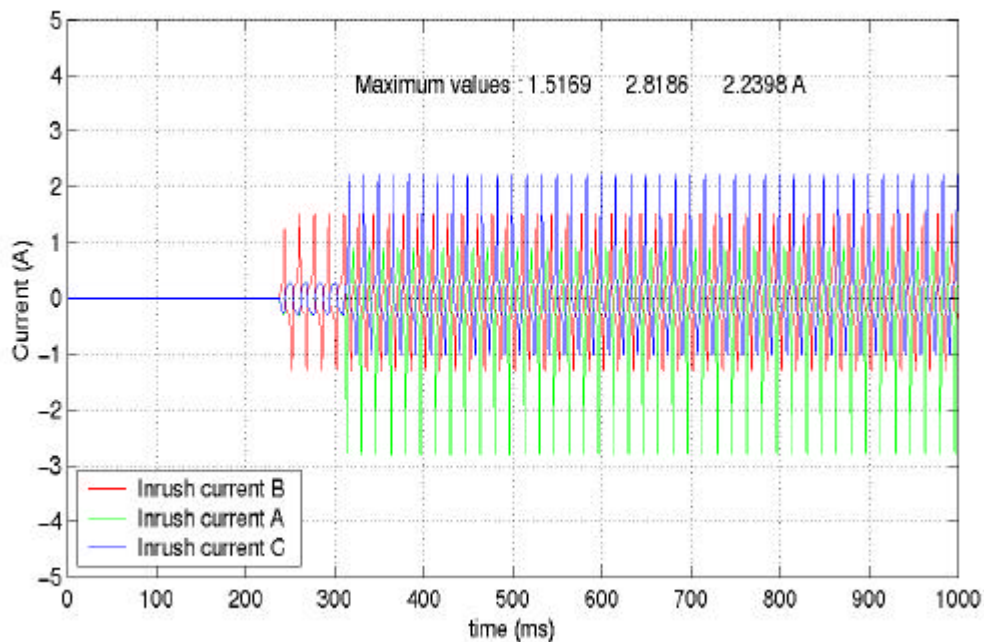

Figure 22. Inrush currents at energisation of a 315kV transformer from the HV side with controlled switching.

2.3 Practical Methodologies for Controlled Energising of Unloaded Transformers

2.3.1 General

The preceding sections have described, in a largely theoretical way, controlled energisation of unloaded transformers and the benefits that can be achieved. In practice there are three control philosophies that are presently in use or being adopted. These can be summarised as follows:

- Energising at fixed targets without considering the residual flux.
- Energising at targets calculated by algorithm making use of the measured residual flux (having an integral relation to the load side voltage) at the previous interruption.

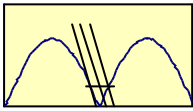

- Energising at fixed targets optimised on the basis of a preceding controlled de-energisation resulting in a known residual flux.

2.3.2 Energising at a Fixed Target Without Consideration of Residual conditions

This philosophy is the one that has been used for many years and is not described in detail here. However it is noteworthy that the philosophy is still useful when energising transformers having a large parallel capacitance that will result in a significant reduction of the residual flux after de-energising [10].

2.3.3 Energising on the basis of measured residual flux

This philosophy is the most sophisticated of the three but requires the access to the transformer voltages which may not always be available depending on application and substation layout. This method has been described in some detail in the preceding sections.

2.3.4 Energisation on the basis of planned de-energisation

The third philosophy can be considered as an intermediate solution between the ideal one of using flux measurement and doing nothing. It is reliant on the transformer de-energisation being a planned operation such that the de-energisation conditions are well defined. This is unlikely to be the case for protection operations, for example. Figure 23. shows a typical substation arrangement where planned de-energisation would be a possible solution. This philosophy does not require flux measurement but relies on “fixing” the residual flux in a well defined manner by means of controlled opening.

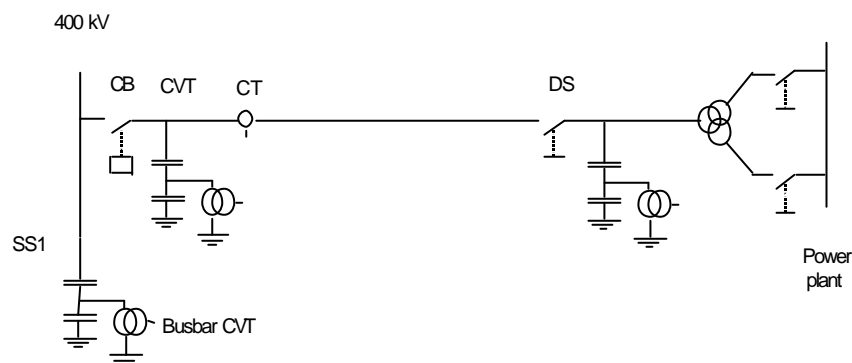

Figure 23. Typical arrangement suited to controlled transformer energisation on the basis of controlled de-energisation.

The magnetising curve of a typical transformer is shown in Figure 24. together with the resulting steady state magnetising current. The steady state no-load current in a modern transformer with a grain-oriented steel core is typically in the order of 0.1 - 0.5 per cent of the rated current. The waveform is far from sinusoidal and the peak value is normally 2.5 times the rms value. Generally speaking, circuit-breakers are able to chop this current, even at its maximum.

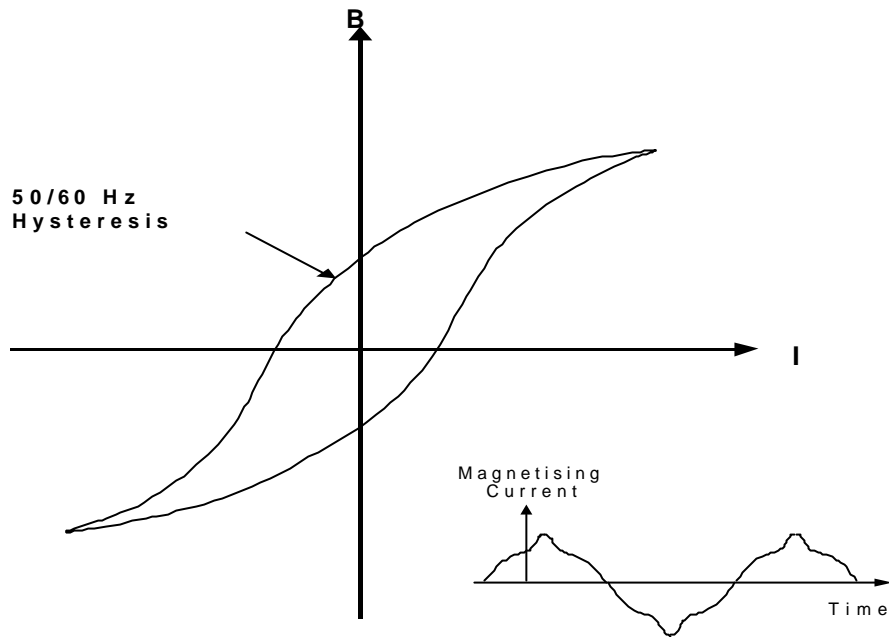
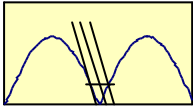

Figure 24. Typical magnetizing curve and corresponding steady state magnetizing current.

When an unloaded transformer is de-energised the circuit-breaker will tend to chop the small magnetising current. Upon chopping, the current in the transformer winding falls to zero with a speed that depends on the parallel capacitance. The current in this period is aperiodic but, over a short duration, can be considered to be sinusoidal with a frequency of some hundred Hz. The effective rapid increase in frequency represented by the rapid decay of current to zero modifies the magnetising characteristic of the transformer as shown in Figure 25. The modified shape of the hysteresis loop is due to the superposition of an ellipse representing the linear behaviour of eddy current losses.

Current chopping results in stored magnetic energy in the load inductance, L , which, due to the non-linearity of the iron core, will be only partly released. The recoverable energies is defined by the equation:

$$W = \eta * \frac{1}{2} * L * i_{ch}^2$$

in which η is the magnetic efficiency, which, for modern transformers, is in the range of less than 0.1 [20]. The relationship between the released and recoverable energy can be seen graphically in Figure 25. Residual fluxes of the order of 80% are considered realistic.

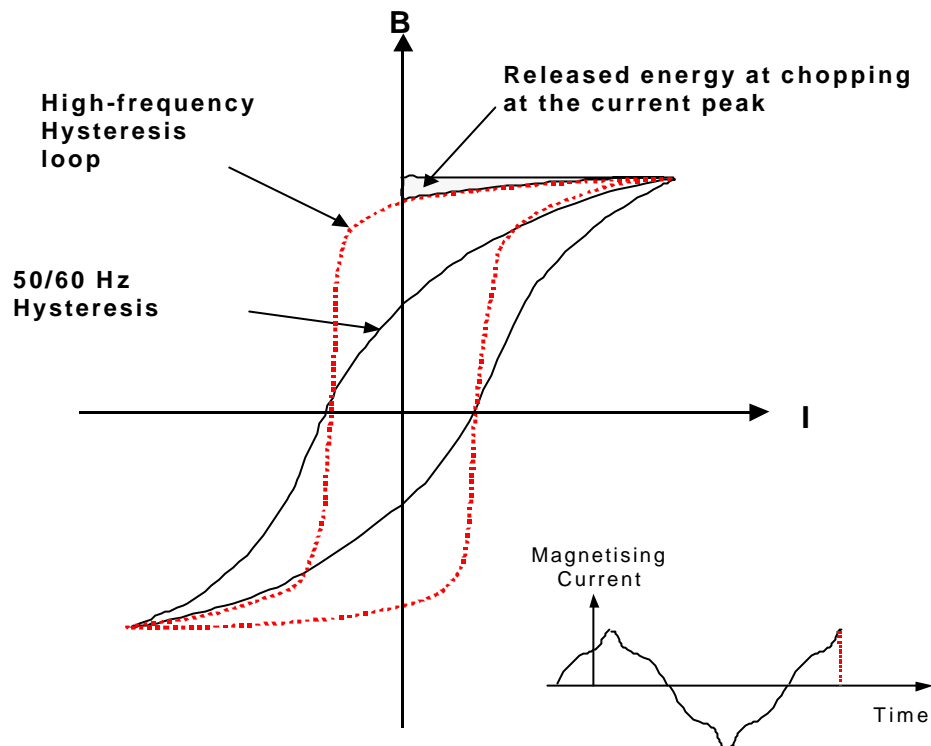
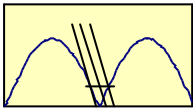

Figure 25. Magnetizing curve at high frequencies. Current chopping at the peak of the current leads to a released energy that is much less compared to that at power frequency return of the current.

The above explained behaviour can, in conjunction with controlled opening, be used to “fix” a known residual flux level in the transformer core. The limited release of energy in combination with a fast dielectric recovery of the circuit-breaker makes an accurately controlled interruption relatively uncomplicated. In the event of an unsuccessful interruption i.e. re-ignition of the circuit-breaker, there is only a very small likelihood that the resulting flux will be significantly different from the intended one. This is the case because the contribution of the re-ignition to the load side “voltage-time” characteristic is small [20].

Having achieved a well defined residual flux level in the transformer core subsequent controlled energisation can be implemented relatively simply. The choice of controlled opening instant can be used to optimise the residual flux level to suit the needs of the subsequent energisation.

If the substation layout and operating procedures are such that the transformer is switched alternatively from either side this philosophy requires that any de-energising (last circuit-breaker to open) is followed by an energising (first circuit-breaker to close) from the same side. The “locked” opening conditions when de-energising from one side do not correspond to the “locked” conditions related to energising from the opposite side.

The philosophy of energisation on the basis of controlled de-energisation can be summarised as follows:

- The required algorithms are simple and can be adapted to any type of transformer.

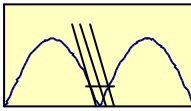

- Load side voltage measurements are not required.
- Controlled interruption can be used to “fix” the residual flux (and reduce the TRV stress across the circuit-breaker).
- The level of residual flux can be optimised to simplify the targeting at energising.

However, the effects of circuit-breaker grading capacitors and some network disturbances that influence the residual may prevent the use of this strategy.

2.4 Conclusions

The preceding sections have summarised a number of strategies/philosophies for controlled energisation of transformers. These vary in both effectiveness and complexity but all provide some potential benefits for the switched transformer and/or the associated power system. The choice of a particular strategy/philosophy is heavily dependent on the available facilities (measurement points, existing circuit-breaker, etc) and the intended results.

If the aim is simply to reduce mechanical and electrical stresses all strategies can be expected to provide benefits. If the aim is more complex e.g. to control TOV's and cater for all system switching & restoration scenarios, a commensurately more complex controlled switching system will be required. This may need to cater for residual flux measurement and worst case circuit-breaker uncertainties. Additionally, the required levels of reliability are likely to be different since a single mal-operation in the latter case may be very serious but in the former case will probably be unimportant.

3 Controlled short circuit and load interruption

3.1 Theoretical reduction of interrupter wear by controlled switching

All medium voltage and high voltage circuit-breakers have well defined minimum arcing times when interrupting fault currents. These minimum arcing times are the minimum time intervals the circuit-breaker requires from contact separation to a current zero where successful interruption occurs. Typical minimum arcing times are in the range of 7-9 ms for terminal fault and short line fault interruption although times as short as 2-3 ms occur in medium voltage vacuum circuit-breakers.

Since contact separation of an uncontrolled circuit-breaker can occur at any point on the power frequency cycle, the average arcing time is significantly longer than the minimum. Consequently excessive contact and interrupter wear occurs. Figure 26. shows the results of a numerical simulation for a generator circuit-breaker. The mean values of the integral \int^2 during the arcing time t_{arc} are plotted for an assumed minimum arcing time of 7 ms. “a, b and c” represent the phases on the low-voltage side of a delta-wye connected transformer, “R, S and T” the phases on the high-voltage side, and g denotes ground.

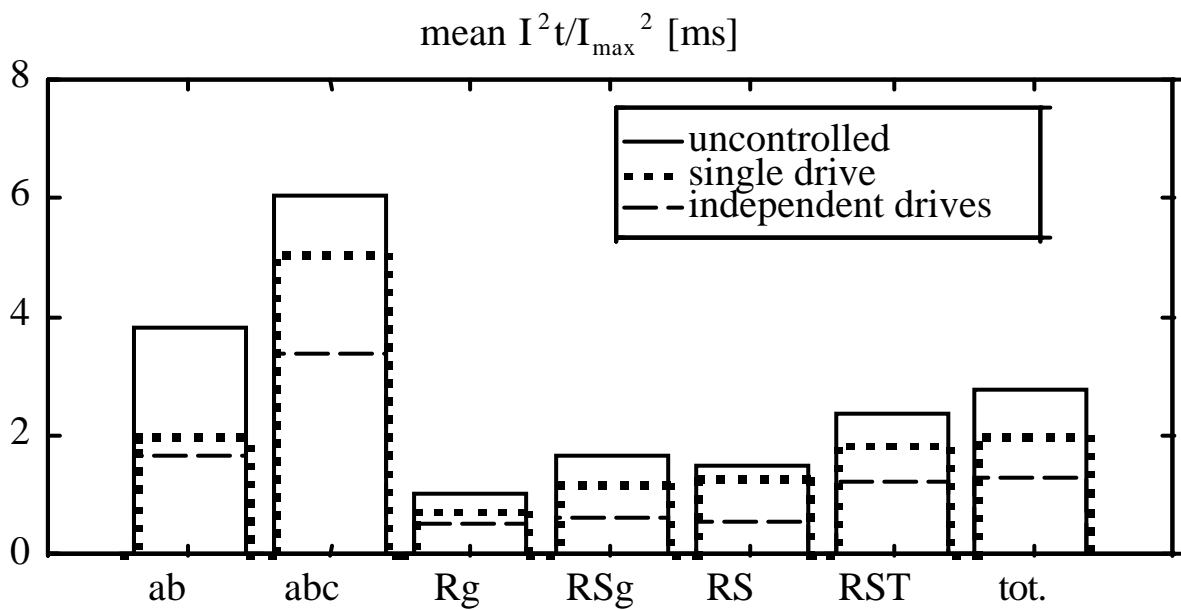
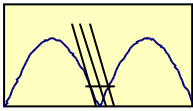

Figure 26. Reduction of the $I^2 \times t_{arc}$ by controlled opening (depending on the fault type)[13]

The study considered several cases in terms of fault location and the type of the fault e.g. single phase to ground (Rg), 2 phases to ground (RSg), three phases (RST, abc) and between two phases (RS,ab).

A comparison is made between three situations: an uncontrolled circuit-breaker (full line), a controlled circuit-breaker with a single drive and simultaneous contact opening (dotted line) and a controlled circuit-breaker with three independent drives (broken line). The diagram shows clearly that independent control of each phase reduces the contact stress to about half for all fault locations and fault types. In the case of only one drive controlled switching can still achieve a significant reduction of the integral I^2 . This is particularly true for faults at the low voltage side.

Clearly the exact relationship between I^2 and interrupter wear is heavily design dependant and must be considered in detail by the designers of switchgear.

3.2 Controlled Fault Interruption - Practical Considerations

Clearly any use of controlled switching to control fault interruption requires detailed coordination with protection systems. It is particularly important that protection performance is not compromised. Typical aspects of protection system design that require consideration are:

- Permissive or definite operation of the controller i.e. is the protection operation reliant on, or supplemented by, the controller.
- Redundancy – the possible need to use multiple controllers to match protection redundancy levels.
- Possible need to control of multiple circuit-breakers with different characteristics.
- Special situations such as faults located between circuit-breaker and instrument transformer and busbar faults requiring operation of multiple circuit-breakers.

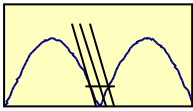

- Effect of circuit-breaker fail.

Annex 1 shows a schematic protection & control arrangement incorporating controllers.

Interruption of fault currents should normally be completed as quickly as possible and typical protection relays require between 6 ms and 25 ms to send a tripping command to the circuit-breaker. The introduction of controlled fault interruption must not result in any significant increase in fault interruption time with the possible exception of the introduction of a short delay required to optimise the arcing time. This gives the controller an extremely short period of time to evaluate the fault type and compute the tripping instant for an optimal arcing time. In order not to introduce additional delays this evaluation must occur within the normal operating time of the protection relay. A study carried out some years ago [11][12] demonstrated that, by “conventional” evaluation of the current signals, prediction of the current in three phases including asymmetries requires around 14 ms providing computing power is not a limitation. A novel alternative method was presented and this is summarised below. The adoption of this method may facilitate greater use of controlled fault interruption in the future.

Controlled switching of loads such as capacitor banks or shunt reactors relies on the fact that the angle between the voltage and the current is well defined and stable. This is not true under fault conditions the angle between the voltage and current can vary. In order to cater for this, it is advantageous for any controller being applied for fault interruption to continuously evaluate these parameters and make calculations in parallel with the protection relay(s) prior to any command being sent to the circuit-breaker.

The requirements for the controller are further complicated in cases other than straightforward three phase tripping. Where single phase tripping is used a delayed three phase tripping command may be sent in the event of a very high impedance fault. The various switching scenarios which result from such systems must be taken into account by the controller. Furthermore, phenomena such as evolving faults i.e. faults that change their characteristics within the switching period must be catered for. A typical example is a primary fault in a single phase leading directly to subsequent faults in one or both of the other phases. Even if the initiating fault is cleared successfully the parameters in the other phases must continue to be monitored to cater for such subsequent events.

A particularly difficult case to cater for using this method is closure, either manual or protection initiated, onto pre-existing faults since pre-fault current conditions are not available to the controller. Voltages may or may not be readily available. In such cases it may be possible to make use of a “memory” of the last operational conditions however these conditions require special consideration on a case by case basis. Closure effects can be further complicated by issues such as trapped charge.

3.3 Rapid Evaluation of Fault Condition

In [12] a method is introduced which allows rapid evaluation of any fault condition such that a suitable tripping instant can be identified within an appropriate timescale. The procedure has the two following steps:

3.3.1 Determination of fault type

Initially the basic fault type has to be determined i.e. single phase, two/three phase, grounded or ungrounded. A procedure is detailed in [12]. The basic principle therein requires

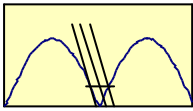

monitoring of voltages and currents before, and immediately after fault inception. The characteristics (phasor representation) of the currents and voltages in the three phases are calculated, processed and the result is compared with pre-calculated values in a look-up table. Total computing time for this activity is approximately 1 ms for a state-of-the-art signal processor such that the fault type is known within a quarter of a cycle. An alternative method which is also introduced in [12] is the use of a neural network which is “trained” in advance by simulation.

3.3.2 Determination of the tripping moment

Having identified the fault type an algorithm, termed the “safe point algorithm” [13], is used for determination of a suitable tripping moment. This algorithm uses knowledge of the fault type and measurements of the current waveform during the first quarter cycle to predict a set of points (termed safe points) which are close to the real current zeros which occur during the opening cycle of the circuit-breaker. This computation also takes approximately 1 ms. Having calculated these safe points, the controller can use them to optimise the timing of the tripping signal to the circuit-breaker.

Overall, this procedure takes 1-2 ms in excess of half a cycle. It is sufficiently fast that controlled fault interruption can be reasonably considered however, to date, only laboratory functionality has been proven. Experience from field applications is not available.

3.4 Controlled load interruption

Figure 26. shows that, even for breakers with simultaneous opening, a reduction of interrupter wear can be achieved. This is also equally valid for load and fault interruptions. Whilst load interruption is not normally a significant stress for the interrupter there are situations where circuit-breakers switch load very frequently and the maintenance regime might become a significant cost factor. Such a case might be the generator breaker in pump storage plant which may operate in excess of twice per day and would have a maintenance regime dominated by contact wear issues.

3.5 Conclusion

The preceding sections demonstrate that controlled interruption of load and fault currents is within the capabilities of available, or easily developed technology. The primary benefit of controlled switching in these applications is a reduction of circuit-breaker wear however, it must be stressed that this is not a defining factor for the majority of circuit-breakers, particularly at transmission voltages. The decision to adopt controlled switching will be a primarily financial assessment between the costs of application and the avoided cost of maintenance. With the advent of modern protection and control systems in which controlled switching will become an embedded software issue this economic assessment is likely to migrate in favour of more widespread use of controlled interruption techniques.

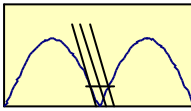

4 Uprating of circuit-breakers

For many years the addition of controlled switching has been discussed as a potential means for “uprating” circuit-breakers. For the purposes of this document uprating is considered to mean an increase in basic performance (e.g. rated voltage, rated current, performance class) such that removal or incorrect operation of the controlled switching system would lead to the possible operation of the circuit-breaker outside its proven strength and capability. This definition of uprating leads to the potential for exceeding the capability of the circuit-breaker such that the potential failure mode and the reliability and testing of the overall controlled switching system become of paramount importance. Applications such as avoidance of re-ignition during reactor switching are not covered by this definition although there is clearly some improvement in performance in this case.

As a guiding principle, the introduction of “uprated” circuit-breakers and their associated control systems should be proven to result in no increase in the probability of failure when compared to conventional, fully rated, circuit-breakers. If an increase in failure probability is accepted this should be on the basis of a risk assessment taking into account the potential consequences (e.g. disruptive failure).

The key factor in gaining acceptability for such “uprated” circuit-breaker systems is demonstration of the reliability aspects. Conventional testing regimes endeavour to give confidence that circuit-breakers are able to operate safely across their entire operating range (control voltage, drive condition, ambient conditions etc). Being relatively simple mechanical systems the extremes of the operating envelope are quite easy to ascertain and the probability of operating outside this envelope is very small (providing non-operation is excluded). On this basis fully tested circuit-breakers are considered to provide an acceptable level of safety.

In general terms, for uprating purposes, controlled switching is used to restrict the range of arcing times over which the circuit-breaker is proven to perform its intended function. In order to maintain an equivalent level of safety the probability of the entire “uprated” controller-breaker system operating outside its target range must be less than or equal to the probability of the unaided circuit-breaker operating outside the extremes of the tested envelope. Assuming that the controller breaker system incorporates a circuit-breaker within its overall reliability this equivalent reliability can only be achieved with an infinitely reliable controller and associated auxiliaries.

This does not preclude the use of controlled switching to uprate circuit-breakers however it leads to the conclusion that some compromise between cost reduction and the highest level of safety will be required. It also leads to the conclusion that testing regimes for such combinations must be developed such that the entire system is proven to a given level of reliability. For such applications controllers should form an integral part of the circuit-breaker equipment and be fully tested as such.

To date there is little evidence that utilities are willing to pursue this route however, the following sections detail the uprating potential in a number of key areas.

4.1.1 *Capacitive current interruption*

The interruption of small capacitive currents, and the associated high magnitude, fundamental frequency, 1-Cosine TRV, are well reported and present little difficulty for circuit-breakers in

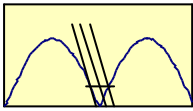

respect of the initial (thermal) interruption. The potential uprating benefits of applying controlled switching relate to the subsequent probability of re-strike. It is notable that IEC standards do not recognise the concept of “re-strike free” and refer only to “low” or “very low” probability of re-strike.

Since successful capacitive switching relies on the dielectric strength of the opening gap being greater than the applied voltage at all points and since the strength of the gap is primarily related to contact spacing there is a strong correlation between capacitive switching performance and contact speed. By controlling the opening instant of the circuit-breaker such that current zero (and hence interruption) always occurs with a relatively large contact gap the probability of re-strikes can be reduced and enhanced performance achieved.

To demonstrate this, investigative tests have been performed on an SF₆-gas circuit-breaker to determine the voltage withstand capability during contact opening. The tests were performed under different conditions to study the influence of contact speed variation and gas pressure variation on the performance. The influence of contact burn-off was studied by means of three short-circuit interruptions at 60% of the rated short-circuit breaking current (pre-conditioning test T60 as defined by IEC 62271-100 for Class C2 circuit-breakers).

In substitution for performing a very large number of full scale capacitive current interruption tests for the determination of the voltage/frequency limitation for random re-strikes a “cold characteristic” test was used. Voltage was applied across the contacts during opening the breakdown voltage versus time or stroke was plotted. Even though the circuit-breaker is not conducting any current prior to the instant when the voltage is applied the results have shown good similarity compared to “full scale” testing and this method is believed to give a good representation of the RRDS.

The common experiences, based on lots of development tests, are also that the minimum arcing time sets the limit for the re-strike-free performance. In an ideal test circuit this minimum arcing time is shorter than half a millisecond which neglects the impact of arcing prior to the voltage stress.

A series consisting of five tests and under following conditions was performed:

- Test 1: New CB pressurised to 0.60 MPa(abs) and with low contact speed (reference test)
- Test 2: New CB pressurised to 0.43 MPa(abs) and with contact speed increased by 9 per cent
- Test 3: Aged CB pressurised to 0.43 MPa(abs) and with contact speed increased by 9 per cent
- Test 4: New CB pressurised to 0.60 MPa(abs) and with contact speed increased by 9 per cent
- Test 5: Aged CB pressurised to 0.60 MPa(abs) and with contact speed increased by 9 per cent

The test circuit that was used is shown in Figure 27.

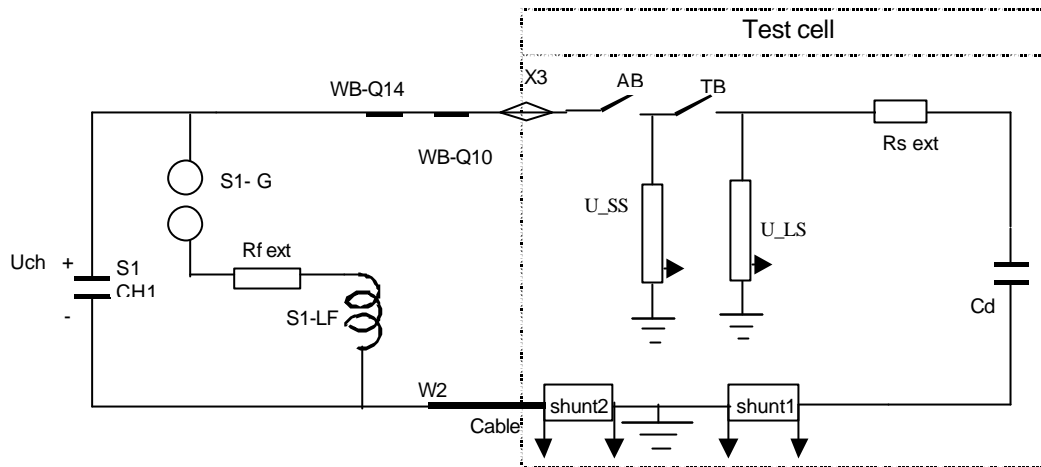
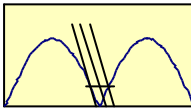

Figure 27. Test arrangement using the synthetic test installation for RRDS determination.

The test circuit used had a current limiting resistor and was arranged such that the circuit-breaker was exposed to a voltage with a 1-cosine wave form with a frequency of about 160 Hz. The voltage was applied across the circuit-breaker during opening operation and at various contact distances. Both voltage polarities were tested. The maximum charging voltage for the selected circuit did not allow for voltage break downs if the "arcing time" was exceeding about 8 ms.

The results of one typical test series, Test 2, are shown the Figure 28. below. To evaluate the performance, the recovery voltage at real capacitive current interruption is drawn in the figures and starting after arcing time zero (most critical arcing time). Three typical recovery voltages are drawn in the graph. In addition, an estimation of the maximised performance is shown. The uprated performance is represented by the green line and is achieved by controlling the contact parting to result in suitable arcing times. For conservative reasons a margin of 10 per cent between recovery voltage and borderline has been considered.

The conclusion of these tests is that short arcing times would cause the circuit-breaker to re-strike for frequencies above 50 Hz. However, the circuit-breaker would be virtually re-ignition and re-strike free at 66 Hz and at a voltage increased by about 10 per cent if the opening was controlled in such a way that arcing times shorter than 4 ms could not occur. Since the test circuit did not allow for voltages high enough to cause voltage break downs at longer times than about 8 ms no exact limit for the uprating can be drawn and the estimation is a little bit conservative.

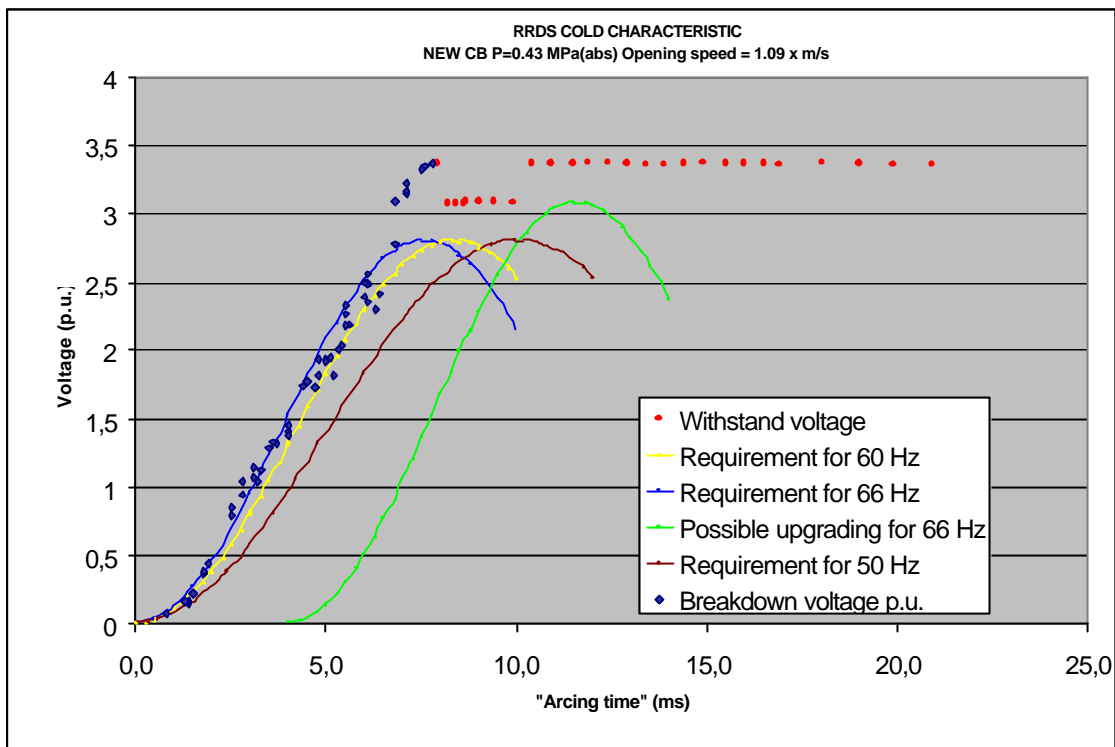
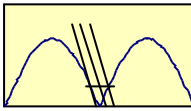
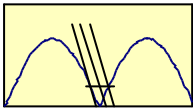

Figure 28. Test 2: Result of RRDS determination with filling pressure 0.43 MPa(abs) and increased contact speed. CB in new condition.

The following conclusions can be drawn from these tests.

- Controlling the contact parting instant at interruption of capacitive loads can permit adoption of a lower gas density.
- Controlling the contact parting instant at interruption of capacitive loads can permit use of a lower contact speed.
- Controlling the contact parting instant at interruption of capacitive loads can reduce the probability of re-strikes by increasing the voltage withstand margin and improving immunity to scatter in the early stage.
- Controlling the contact parting instant at interruption of capacitive loads can allow a circuit-breaker to operate in networks with higher fundamental frequencies than that for which it was designed.
- Ageing the circuit-breaker by 3 interruptions of T60 does not affect the performance significantly.
- If re-strike free performance at capacitive current switching is a limiting factor, controlled interruption is a useful tool for uprating.

The preferred preset arcing time (3 - 4 ms) would not be longer than average at non-controlled switching and therefore should not lead to an increased burn-off. Assuming a three-pole circuit-breaker with simultaneous contact parting and with an even distribution of first or last pole to clear the average arcing time would be in the same range as the pre-set controlled arcing time.



4.1.2 Short-circuit Interruption

Every circuit-breaker type is designed to cope with the stresses within their rating and with randomly disposed contact separation. A fundamental requirement is that the circuit-breaker must succeed to interrupt the current after any arcing time within an "arc extinguishing window" covering at least half a cycle. Within the defined "arc extinguishing window" the circuit-breaker performance will vary depending on contact distance, pressure build-up, gas flow etc.

Based on development tests there are results indicating that arcing times in the intermediate region give a higher safety margin compared to arcing times closer to the ends of the "window" as illustrated in Figure 29. By the use of controlled contact opening it would be possible to pre-set the arcing time within the limited time interval resulting in the optimised interrupting performance.

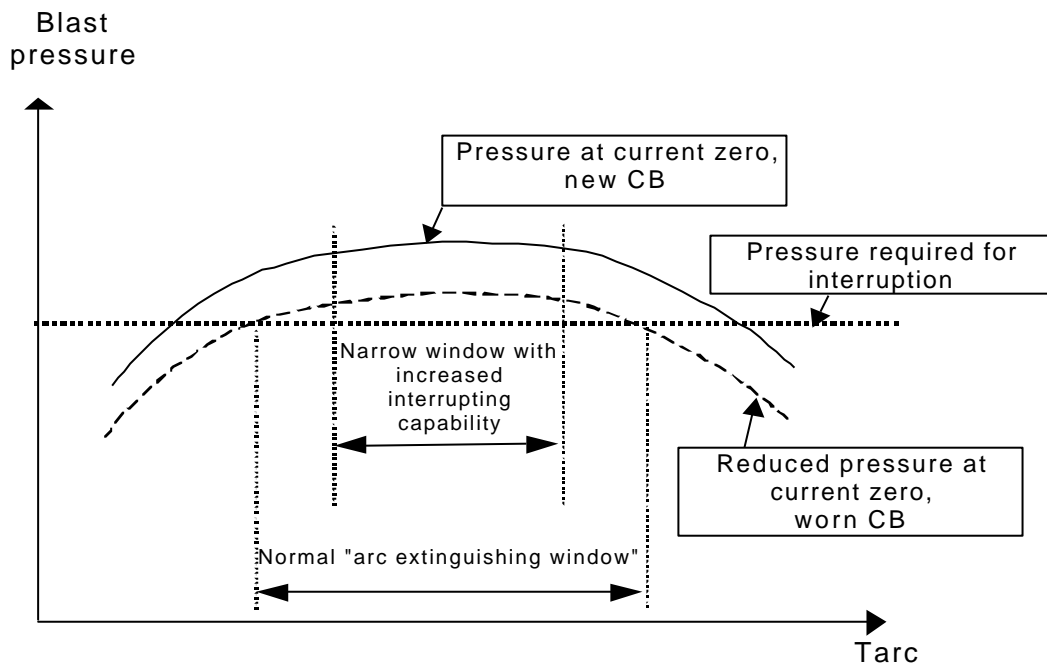

Figure 29. Schematic figure showing the pressure build-up at current zero in the compression chamber of a circuit-breaker versus arcing time.

Such development tests only indicate possibilities for increased performance for fault interruptions. Type of fault i.e. short-line fault or terminal fault, single/three-phase fault, magnitude of current, network frequency etc. would require extensive investigations, for every circuit-breaker type, to quantify the potential and to determine the control algorithms.

Controlling fault interruptions is at present controversial but tests indicate a potential for increased performance and lifetime endurance. No attempt has yet been made to quantify the potential gains.

The following table is a summarised list of areas where controlled switching may provide possibilities for upgrading.

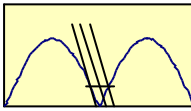

Table 3. Identified switching cases where controlled switching may increase rating.

CASE	CONTROL REQ'T	WHAT IS ACHIEVED	INCREASED RATING OF . .	RATING INCREASE
Capacitive de-energising	Opening at optimum arcing time	Increased voltage withstand	Increase of voltage rating	1 step (e.g. 145 to 170 kV)
			Higher rated frequency	50 to 60 Hz
			Lower ambient temperature class.	Lower ambient temperatures can be met (e.g. -40°C to -50°C) on same type of CB.
			Higher capacitive switching class.	Class C1 breaker can become class C2 breaker free of charge (except the cost for controller)
Filter bank switching	Opening at optimum arcing time	Increased voltage withstand	TRV withstand.	Additional application of standard CB.
Line energising	Optimum closing and re-closing	Reduced transients	With the combined use of line arresters and controllers "smaller" breakers can be used	1-2 voltage step(s) up-rating (300 kV CB to be used for 420 kV)
Fault current interruption	Opening at optimum T_{arc}	Increased I_{SC} performance	Increased current breaking. (possible increased break time depending on speed of algorithms).	Approx. 10%-20% depending on type of fault condition
			Lower ambient temperature class	Lower ambient temperatures can be met (e.g. -40°C to -50°C) on same type of CB.
Missing current zeros	Opening at optimum (delayed) time	Ability to interrupt highly offset currents.	Current interruption	Successful interruption instead of unsuccessful

5 Interruption of small inductive currents using circuit-breakers without a re-ignition free window

5.1 Basic Principles

The basic aim of controlled interruption of inductive current is to further improve the interrupting performance of a circuit-breaker and thereby ensure a very high probability of re-strike/re-ignition free performance. In most cases the last loop of the current in each phase can be divided into two regions, an acceptable contact parting period resulting in re-ignition free interruption and a critical contact parting period resulting in re-ignitions. In such cases it is common practice to centre the contact parting in the acceptable contact parting area thereby taking care of mechanical as well as dynamic dielectric scatter. However, this approach is not possible if the acceptable target window within the last loop is very narrow, or non-existent. These conditions may exist for circuit-breakers with very low RRDS or due to the occurrence of very high chopping overvoltages. In such cases controlled contact parting immediately prior to the penultimate current zero may be appropriate.

This method forces the circuit-breaker to re-ignite at a very short contact spacing, at every interruption. However, since the voltage withstand under these conditions is only a small

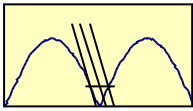

percentage of the recovery voltage the severity of the re-ignition transients are limited. There are a number of known installations using this strategy and the service experience to date has been good.

Since the strategy forces the circuit-breaker to undergo frequent re-ignitions it is vital that the dielectric co-ordination of the circuit-breaker interrupter at short contact distances is good. The ability of the circuit-breaker to interrupt the high-frequency current at re-ignition must also be evaluated to avoid multiple re-ignitions and voltage escalation.

5.2 Example

The following sections illustrate, by example, this strategy

As reactor size decreases so the interrupted current decreases. However, for particularly small reactors, and hence currents, chopping overvoltage magnitude may exceed re-ignition overvoltage magnitude as the primary concern. Figure 30. illustrates the relationship between reactor size and chopping overvoltage.

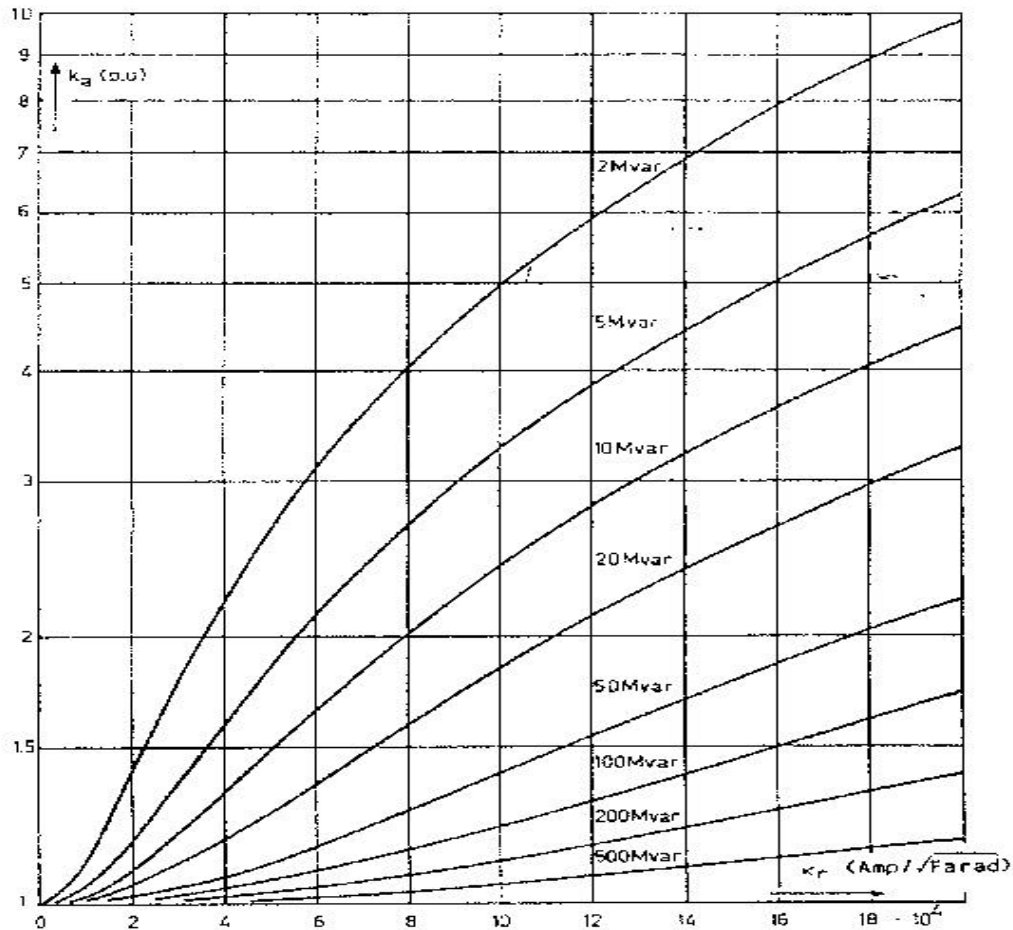
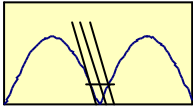

Figure 30. Chopping overvoltage at reactor de-energising



For directly earthed reactors (the most common arrangement today), the maximum chopping overvoltage is the per unit magnitude of the suppression peak overvoltage (k_a) as a function of the crest phase to earth voltage. This is given by the expression:

$$K_a = \sqrt{1 + \frac{3N^2}{2Q}}$$

where

- Q is the three phases rated reactor power
- ω is the angular power frequency
- λ is the chopping number of the circuit-breaker
- N is the number of breaking units per pole

For unearthed reactors, the highest overvoltage to earth is the overvoltage generated at the recovery peak which is given by the equation:

$$K_c = 0,5 + 1,5 \sqrt{1 + \frac{N^2 C_s}{Q(C_s + C_L)}}$$

where

- Q is the three phases rated reactor power
- ω is the angular power frequency
- λ is the chopping number of the circuit-breaker
- N is the number of breaking units per pole
- C_s is the supply side capacitance
- C_L is the load side capacitance

For a specific circuit-breaker and neglecting the capacitances, chopping overvoltages depend on the reactive power of the reactor. Therefore, as the reactor size is reduced, elimination of re-ignitions and chopping overvoltages becomes more difficult since the re-ignition free window becomes narrower.

As detailed above a common strategy today is to target contact opening at an instant such that the arcing time exceeds the minimum arcing time for re-ignition free interruption. For typical sized reactors (> 50 MVAR) in combination with “normal” SF₆ circuit-breakers a suitable target area will normally exist and the chopping overvoltage, k_a , will normally be < 1.35 . However, if the reactor size is reduced this situation is modified as demonstrated by the following example in which a circuit-breaker with a pre-defined RRDS (p.u./ms) and chopping characteristic is considered.

To simplify the calculation for illustrative purpose, following assumptions have been made:

- Recovery voltage has not been taken into account
- The calculation has been made on single-phase basis.

Table 4. shows the calculation of the re-ignition free window and the nominal target for re-ignition free interruption of a 50MVAR reactor. Table 5. shows the equivalent calculation for a 5MVAR reactor. In both cases the RRDS of the circuit-breaker is taken as 0.5 p.u./ms. Possible variations in chopping overvoltage with arcing time are not considered in this example.

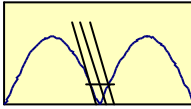
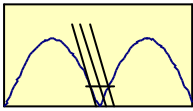

Table 4. Calculation of target window for de-energisation of a 50 MVAR reactor

Start of window (penultimate current zero)	ms	0.00
Voltage across reactor at chopping (90° phase shift vs. current)	pu	1.0
k_a for Q = 50 MVAR		1.35
Chopping over voltage (u_{ma}) for Q = 50 MVAR	pu	$1.35 \times 1.0 = 1.35$
Peak value of TRV ($u_{ln} + u_{ma}$) (load - source side voltage)	pu	$(1+1.35) \times 1.0 = 2.35$
Typical dielectric characteristic of CB	pu/ms	0.50
Minimum arcing time for re-ignition free interruption	ms	$2.35/0.50 = 4.7$
TRV starts at	ms	10.0
End of window (latest contact separation for re-ignition free interruption)	ms	$10.0 - 4.7 = 5.3$
Width of window (End of window - start of window)	ms	$5.3 - 0.0 = 5.3$
Nominal target (Contact separation at center of the window with reference to second last current zero)	ms	$5.3/2 = 2.65$
Remaining tolerances:		
End of window – Nominal target	ms	$5.3 - 2.65 = 2.65$
Start of window – Nominal target		$0.0 - 2.65 = -2.65$

Table 5. Calculation of target window for de-energisation of a 5MVAR reactor

Start of window (penultimate current zero)	ms	0.0
Voltage across reactor at chopping (90° phase shift vs. current)	pu	1.0
k_a for Q = 5 MVAR		3.0
Chopping over voltage (u_{ma}) for Q = 5 MVAR	pu	$3.0 \times 1.0 = 3.0$
Peak value of TRV ($u_{ln} + u_{ma}$) (load - source side voltage)	pu	$(1+3.0) \times 1.0 = 4.0$
Typical dielectric characteristic of CB	pu/ms	0.50
Minimum arcing time for re-ignition free interruption	ms	$4.0/0.5 = 8.0$
TRV starts at	ms	10.0
End of window (latest contact separation for re-ignition free interruption)	ms	$10.0 - 8.0 = 2.0$
Width of window (End of window - start of window)	ms	$2.0 - 0.0 = 2.0$
Nominal target (Contact separation at center of the window with reference to second last current zero)	ms	$2.0/2 = 1.0$
Remaining tolerances:		
End of window – Nominal target	ms	$2.0 - 1.0 = 1.0$
Start of window - Nominal target		$0.0 - 1.0 = -1.0$



From these results it is clear that the same circuit-breaker switching a smaller reactor load leads to a substantially reduced target for re-ignition free operation. Furthermore, the magnitude of the chopping overvoltages will be in the same range or even higher than the eventual re-ignition overvoltages. If controlled opening is attempted with such a narrow target, statistical effects will cause the circuit-breaker to re-ignite relatively regularly and at relatively high voltages.

There are two options to address this problem:

1. Use an over-dimensioned circuit-breaker with a higher RRDS characteristic which will provide a wider target window. This solution is unlikely to be cost effective and it does not solve the potential problem of high chopping overvoltages.
2. Apply controlled opening to the original circuit-breaker with a target contact parting instant well before the penultimate current zero. This will force the circuit-breaker to re-ignite at short contact spacing thereby reducing the inevitable re-ignition overvoltages. High chopping overvoltages will still occur.

In many cases the latter option will prove to be an effective solution.

6 Controlled switching of series compensated transmission lines.

6.1 Introduction

Throughout the world many different line arrangements exist that can be categorised as follows:

- uncompensated lines
- shunt reactor compensated lines
- series capacitor compensated lines
- a combination of shunt reactor and series capacitor compensated lines (normally both operating at the same time)

At present controlled re-closing (and closing) of uncompensated and shunt reactor compensated lines has been applied in service and has delivered the intended suppression of re-energising transients. This section considers the possibilities for extending this approach to cover pure series compensated lines.

De-energisation of an uncompensated no-load line results in a trapped line d.c. voltage evenly distributed along the line. Similarly, in the case of de-energisation of a shunt reactor compensated line there is a well defined line side voltage oscillation defined by the degree of compensation. In both of these cases knowledge of the circuit-breaker characteristics and measurement of the source and line side voltages facilitate re-energisation of the line at instants that will minimise the re-energising transients. Controlled line switching of this type is possible since the line voltage is the same over the length of the line thereby making the

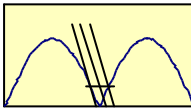

energising instant predictable. Interruption of a purely series compensated line does not result in such predictable conditions.

De-energisation of a series compensated line results in an uneven distribution of trapped charge along the entire length of the line and the precise distribution is influenced by operating conditions. In addition, the maximum line voltage when interrupting a series compensated line will not be limited to about 1.1 p.u. as it is when interrupting an uncompensated or shunt compensated line. The line side voltage measured by a controller at the time of interruption will not be equal to the voltage at the remote end of the line due to the trapped voltage across the series capacitor. Oscillations at the interruption may also lead to very high voltages that are difficult to predict.

From this it is clear that controlled re-closing of purely series compensated lines by selection of optimum re-energising instants will not be as effective as for other controlled line switching applications. Nevertheless, there are some potential benefits and these are explored in the following sections by means of case specific examples.

6.2 Characteristics and Operation of Series compensated lines

This section deals only with pure series capacitor compensated lines or lines with combined series capacitor and shunt reactor compensation where the shunt reactor is connected to the busbar side of the line circuit-breaker (i.e. not forming a part of the line). A typical single-line diagram is shown in Figure 31.

Single-line diagram:

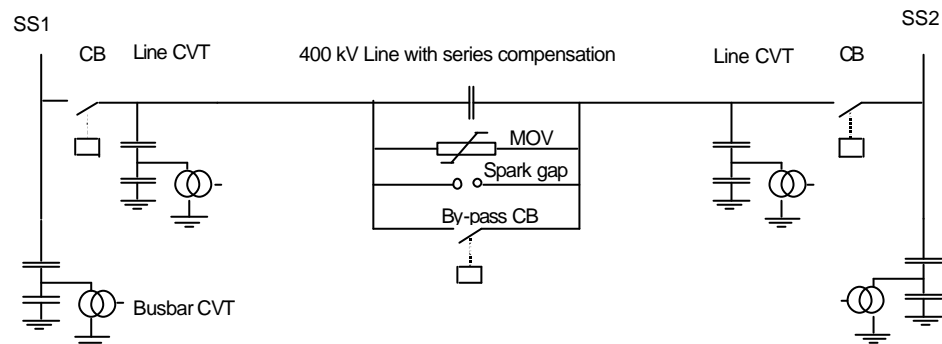
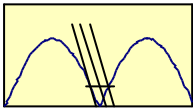

Figure 31. 400 kV line with series compensation arrangement.

There are many different approaches to choosing the location of series compensation units however the optimum location is generally considered to be in the centre of the line. Nevertheless, maintenance aspects and availability of land often dictate that the equipment is located at the end of the transmission line. In a few cases series capacitors have been located at two sites, each being one third of the line length from each end. Arrangements where series capacitors are located on the busbar between cascaded line sections are preferred in some cases.



In addition to the different line arrangements, different operating strategies also exist. For series capacitor compensated lines the following operating strategies, in case of fault clearing, may apply:

- *interruption of faulty phase(s) only.*
- *three-pole interruption of the line regardless of fault type.*

The series capacitor itself is normally protected by a parallel arrangement consisting of a surge arrester in parallel with a spark gap and a by-pass circuit-breaker. The spark gap (which may prove unreliable at high altitudes) may be omitted if fast closing by-pass circuit-breakers are used. Under fault conditions the series capacitor is by-passed by means of either the spark gap (if fitted) or the by-pass circuit-breaker. Spark gap operation is triggered by the current through the MOV as well as a fault current condition detected by the communicating line circuit-breaker relays. The typical time characteristic of the internal discharge resistor circuit in the capacitors does not allow for any discharge within a line re-closing sequence. The line protection sends a simultaneous closing command to by-pass the series capacitor and opening command to the line circuit-breakers.

Different operating conditions may also exist for the by-passing of the series capacitors as follows:

- *by-passing the series capacitor in the faulty phase(s) only when the conditions for by-passing are fulfilled.*
- *by-passing the series capacitors in all phases regardless of fault type. Normally the by-pass switch is slower to close than the line circuit-breakers are to open meaning that the healthy phases will be interrupted in a compensated condition.*

For re-closing of the line there are also alternative strategies among utilities:

- *by-pass breaker remains closed during the re-closing stage leading to re-closing of an uncompensated line. After a successful re-closing the series capacitor will be re-inserted (about 200 ms after re-closing). The re-insertion of the series capacitor may lead to very high dielectric stress across the by-pass circuit-breaker.*
- *re-close after the by-pass breaker has re-opened.*

The following study investigates the suitability of controlled re-closing of a pure series compensated line after a single-phase to ground fault followed by a three-pole interruption. The selected controlled switching algorithm for the simulations corresponds to an algorithm used when switching uncompensated lines and is based on measured trapped charge of the line. Similar studies would be required for other scenarios.

6.3 Example of controlled switching of series compensated line

EMTDC simulations have been made to study a limited number of cases which may occur for three-pole interruption after the initiation of a single-phase to ground fault. It has been assumed that there is a single-phase to ground fault in phase B and that the by-pass arrangements operate (correctly) in phase B only. The characteristics of the studied line are shown in Table 6.

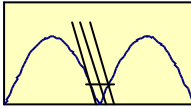

Table 6. Line data of the studied line

	SS1 – Series comp.	Series comp. – SS2
r_+ (Ω/km)	0.0130	0.0136
x_+ (Ω/km)	0.270	0.2534
x_{c+} ($\text{M}\Omega/\text{km}$)	0.240	0.2247
r_0 (Ω/km)	0.210	0.1720
x_0 (Ω/km)	0.770	0.7612
x_{c0} ($\text{M}\Omega/\text{km}$)	0.370	0.424
length (km)	32.6	335.6

Parameters of the series compensation:

39.77 $\mu\text{F}/\text{phase}$

MOV protection level of 203.6 kV. Protection gap operation for twice the normal current ($2 \times 1800 \text{ A}$) or at the maximum MOV energy.

Parameters of the line CVTs:

Top capacitor: 7 nF

Bottom capacitor: 1.1 μF in parallel with (500 H + 10 k Ω)

Characteristics of the supply (on the basis of reasonable transmitted power, short-circuit current and TRV):

410 kV, 50 Hz, SS2 30° leading (transmitting about 900 MW to SS1)

$Z_+ = 28.5 \Omega \ 86^\circ$ (SS1) and $35 \Omega \ 86^\circ$ (SS2) respectively

Local load (both ends) $350 \Omega \ \cos\phi = 0.998$, in parallel with 37 nF

Type of fault:

Single-phase to ground fault either between SS1 and the series compensation or between SS2 and the series compensation. Three-phase interruption of the line 30 – 50 ms after the fault initiation. Re-energised after 200 ms (to limit the calculation time).

Circuit-breaker and controlled switching strategy:

It has been assumed that both line circuit-breakers are identical and have an RDDS of 100 kV/ms and a timing scatter at closing of $\pm 0.5 \text{ ms}$.

Interrupting conditions:

- 1) The circuit-breaker in SS1 interrupts at the very first current zero after contact separation (31 ms after fault initiation) while the circuit-breaker in SS2 interrupts 10 ms later.
- 2) The circuit-breaker in SS2 interrupts at the very first current zero after contact separation (31 ms after fault initiation) while the circuit-breaker in SS1 clears the fault 10 ms later.

It has also been considered that the re-closing does not occur simultaneously at both ends but with a certain time difference. By-pass circuit-breakers in the healthy phases are not operated.

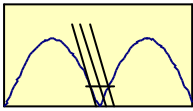

The controlled switching strategy studied is identical to that applied to pure uncompensated lines. It is based on measured line voltages and targets a point after the supply side voltage peak with the same polarity as the trapped line voltage.

Table 7. summarises the cases and operating conditions studied.

Table 7. Switching combinations used for simulation of single-phase fault clearing and re-closing of pure series compensated line.

Case 1	Single-phase to ground fault located close to the series compensation and on SS2 side. CB in SS2 opens last and re-closes last. Current through capacitor will activate the spark gap in faulty phase (8 kA _{peak})
Case 2	As case 1 but CB in SS2 opens first and closes last
Case 3	Single-phase to ground fault located close to the series compensation and on SS1 side. CB in SS2 opens first and re-closes last. Current through capacitor will not activate the spark gap (5 kA _{peak}) and is assumed not to operate for maximum absorbed energy
Case 4	As case 3 but CB in SS2 opens last and re-closes last
Case 5	As case 4 but uncontrolled re-closing of CB in SS1
Case 6	Single-phase to ground fault located close to the series compensation and on SS2 side. CB in SS2 opens last and re-closes first. Current through capacitor will activate the spark gap (8 kA _{peak})
Case 7	As case 6 but CB in SS2 opens first and re-closes first
Case 8	Single-phase to ground fault located close to the series compensation and on SS1 side. CB in SS2 opens first and re-closes first. Current through capacitor will not activate the spark gap (5 kA _{peak}) and is assumed not to operate for maximum absorbed energy
Case 9	As case 8 but CB in SS2 opens last and re-closes first
Case 10	As case 4 but not controlled re-energising (by CB in SS2) as comparison

The results of the simulations are shown in Table 8. (voltages in p.u. where 1 p.u. = 335 kV)

As an example Figure 32. shows the actual waveforms resulting from case 4 of the study. Within Figure 32.

- The top graph shows the line side phase-to-ground voltages on the SS1 side
- The second graph from top shows the currents through the series capacitor
- The third graph from bottom shows the voltages across the series capacitor
- The bottom graph shows line side the phase-to-ground voltages on SS2 side

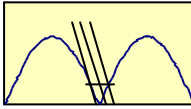

Table 8. Results of EMTDC simulations of single-phase to ground faults on series compensated line and followed by three-pole interruption and re-closing.

Case	Fault side	Gap Activates	CB in SS2 Opens	Max. de-energising transient in SS1	Max. de-energising transient in SS2	CB in SS2 closes	Controlled energising (1)	Maximum energising transient SS1 side	Maximum energising transient SS2 side
1	SS2	Yes	Last	2.3	2.0	Last	Yes	1.5	2.0
2	SS2	Yes	First	1.2	1.0	Last	Yes	1.7	2.2
3	SS1	No	First	1.1	2.5	Last	Yes	1.4	2.5
4	SS1	No	Last	3.3	2.4	Last	Yes	2.2	2.6
5	SS1	No	Last	3.3	2.4	Last	No	2.0	4.9
6	SS2	Yes	Last	2.3	2.0	First	Yes	2.0	2.0
7	SS2	Yes	First	1.2	1.0	First	Yes	2.3	1.2
8	SS1	No	First	1.1	2.5	First	Yes	2.8	1.4
9	SS1	No	Last	3.3	2.4	First	Yes	2.6	2.2
10	SS1	No	Last	3.3	2.4	First	No	4.3	2.2

- (1) Controlled energising according to an algorithm developed for uncompensated lines and based on measured line voltage at the location of the re-closing circuit-breaker.

These results are line specific but show e.g. by reference to cases 4 & 5, that there is some limited potential for improvement by means of controlled re-closing.

By making some approximations (strong supply, no interaction between the phases, no losses, direct transfer of transients through the series capacitor) it can be shown that the first voltage transient in the open ended line at re-closing will be:

$$\hat{u}_r = u_c - u_l + 2 * \sin(\omega * (t_p + 2 * t_l))$$

where:

- u_c = trapped voltage (in p.u.) across the series capacitor
- u_l = trapped line voltage (in p.u.) on the line side with the first re-closing circuit-breaker
- ω = $2\pi f$ = angular frequency of network (rad/s)
- t_p = energising instant (in s), with respect to the source side reference voltage zero with positive derivative
- t_l = travelling time (in s)

Comparisons between computer simulations and calculations using the above formula give almost identical results.

For a series compensated line the voltage, u_c , across the series capacitor, prior to energising, can adopt any value between zero (when by-passed) and a value corresponding to the protection level of the surge arrester. In addition the trapped line voltage, u_l , may be far above 1.1 p.u. which disagrees with most algorithms for controlled line re-closing and also does not fit well to the supply busbar voltage.

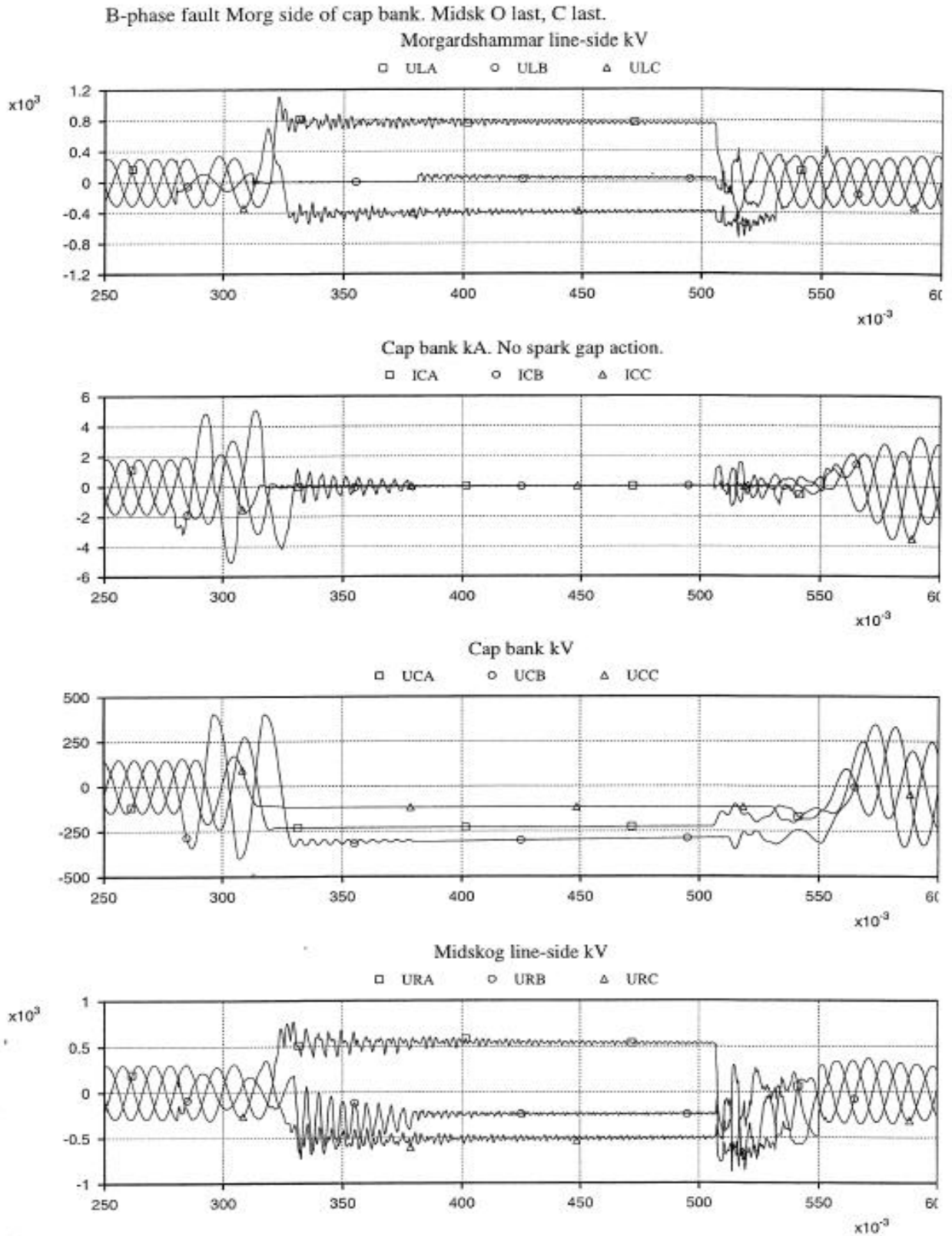
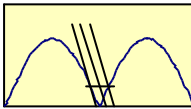
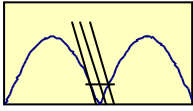

Figure 32. Simulated waveforms for Case 4



6.4 Conclusion

It is possible to reduce the re-closing transients when switching a series compensated line by means of a controller designed primarily for uncompensated lines. As an approximation, re-closing transients can be limited to less than ± 3.0 p.u. with a probability of about 95%. This compares to an extreme value of 5.0 p.u. when no switching transient limitation is applied. It is notable from the preceding studies that line de-energisation can, itself, result in transients exceeding 3.0 p.u. This being the case, and assuming that the line insulation is designed to cater for these conditions, the performance of the proposed controlled re-closing strategy can be judged adequate.

Despite this apparent success, it must be stressed that the use of controlled switching for applications of this type are very heavily influenced by the specific characteristics of the installation. Therefore, when considering such an application it is vital that all relevant system parameters, operating scenarios and targeting strategies are studied thoroughly. For example, issues such as the ability of the controller to determine the trapped voltage which is subject to very large oscillations and the ability to identify a suitable algorithm may make practical applications difficult. This being the case it is foreseen that controlled switching of series compensated lines will remain a very limited, but high value, application.

7 Controlled switching or pre-installed circuit-breakers

7.1 Background

Circuit-breakers are long lifetime items (typically in the range 25-50 years) and, particularly in recent years, power systems changes have been relatively rapid. This often leads to a situation where continued operation of an existing circuit-breaker becomes increasingly unacceptable due to increasing power quality demands and the proliferation of sensitive more loads. In such cases an option that must be considered seriously is the retro-application of controlled switching to pre-existing circuit-breakers.

Much of the preceding work of WG A3.07 has, by implication, been focussed towards new installations where the detailed parameters required for accurate controlled switching can be easily derived in advance of commissioning. Nevertheless, in some cases, retro-fitting of controlled switching is a viable, and cost effective, solution.

Clearly, as with a new installation, successful controlled switching requires some knowledge of the basic operating parameters and sensitivities (e.g. to temperature, control voltage, idle time, etc) of the circuit-breaker. However, in applications where occasional mis-operations are acceptable, such as shunt reactor de-energisation, it may be sufficient to have only approximate knowledge of these factors to achieve a major improvement in overall performance. This demonstrated by the following example.

7.2 Controlled shunt reactor de-energisation using existing circuit-breakers – an example

To date very few utilities have applied controlled switching to existing circuit-breakers. This is primarily due to the need to identify various operational parameters which are not readily accessible in normal operation. Nevertheless, field experience from utilities that have attempted controlled switching using pre-existing circuit-breakers is good.

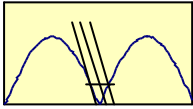

A particular utility has reported use of this technique for shunt reactor switching over the past ten (10) years with good experience. The majority of its controllers (more than 80 units) are applied to existing air blast circuit-breakers controlling shunt reactors on a 735 kV power system. The first controller was commissioned in 1992 and has been the subject of extensive field tests to confirm satisfactory performances of the whole system (CB, controller, shunt reactor). Since this time controlled switching has been gradually introduced to replace the opening resistors and their associated auxiliary chambers. The primary motivation for this change was the high cost for maintaining the auxiliary chambers and their poor reliability.

The utility in question ascertained parameters such as the variation of the opening times with temperature and the stability of the opening time by means of field tests. The re-ignition free window was also obtained from field tests and these and other parameters were used to provide initial controller settings. It has been demonstrated that controlled switching is feasible with limited knowledge of the circuit-breaker characteristics. Further refinement of these initial settings was facilitated by incorporating a “re-ignition alarm” into the controller such that occasional mis-operations could be analysed and necessary adjustments made. Setting and the reliability of this alarm has been a key aspect of this application and, in practice, the alarm has been very effective in indicating circuit-breaker defects.

In this particular example the target window of 3-4 ms was sufficiently large, and the opening scatter of the particular circuit-breaker was sufficiently small, to ensure reliable operation on the basis of limited data. Ultimately the decision to use controlled switching in this case was a simple comparison of costs between the maintenance costs of the auxiliary chambers and the installation costs of the controlled switching including all aspects such as new control cables, drawing modifications and commissioning costs.

For more critical cases such as controlled closing on shunt capacitor banks with existing circuit-breakers it would be necessary to use more comprehensive methods to achieve an improved accuracy. Factors such as the increased mechanical scatter on closing and the reduced target (typically ± 1 ms) make such a case significantly more challenging.

7.3 Possible procedure to check the suitability of an in-service circuit-breaker for controlled switching

As already stated, retro-application of controlled switching normally requires detailed information about the effects of idle time, temperature, etc upon the operating characteristics of the circuit-breaker. These factors ideally need to be ascertained during normal operation with as little interference and modification as possible. Only recently has research begun in this area and this section summarises a procedure which could be used to determine the achievable transient reduction by applying controlled switching in a particular scenario. More detailed information can be found in [16][17]. The procedure can be broken down into a number of key steps as follows:

- The acceptable level of switching transients must be defined taking account of the surrounding power system. The relationship between the transients and the pre-strike voltage must be ascertained. This may be by simulation or by means of system switching tests providing the transients can be tolerated.

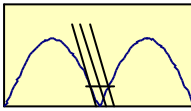

- As far as possible from external indicators, the circuit-breaker characteristics (RDDS, operating times & scatters) and dependencies (idle time, temperature, control voltage, drive energy) need to be identified. Algorithms allowing on-site identification of the RDDS have been developed and tested in a laboratory environment [16][17]. A complementary approach to the determination of the dependencies of the mechanical operation time from external parameters is still the subject of research and no results are available yet.
- The pre-strike voltage as a function of the closing target must be calculated.
- On the basis of the calculated pre-strike voltage the predicted transient overvoltages and currents can be calculated for the particular case. The frequency of occurrence of the worst case transients can also be calculated.

At this stage a determination can be made regarding the acceptability, or otherwise, of the available transient reduction.

7.4 Conclusions

A few utilities have already successfully retrofitted controllers to existing circuit-breakers using basic mechanical timing information. These successful retro-fit applications are, to date, on relatively straightforward cases such as shunt reactor de-energisation where the target window is large. Occasional mis-operations are tolerable and the installations are equipped with alarms to warn of incipient problem.

Methodologies are being developed to permit more robust assessment of the characteristics of in-service circuit-breaker and, in due course, these may facilitate the effective retro-fit of controlled switching to more technically challenging cases.

8 Controller survey

Controlled switching is widely available and controllers are being increasingly applied to small inductive current interruption, capacitor bank and transmission line switching and unloaded power transformer energisation. Working Group A3.07 has attempted to survey worldwide applications of controlled switching by reviewing the number of controllers supplied. Whilst it has proved difficult to ascertain detailed information in all cases e.g. due to the sale of loose controllers for which no application data is available the following summarises the findings of the group. From 1984 until the end of the year 2001 there appear to have been approximately 2500 controllers supplied and installed around the world.

Their operational range covers voltages from 12kV to 800kV, frequencies of 50Hz and 60Hz, a wide variety of climatic conditions and the following major application categories:

- Shunt capacitor energising and/or de-energising
- Shunt reactor energising and/or de-energising
- Transformer energising only or energising supported by controlled de-energising
- Line energising (uncompensated or shunt reactor compensated)

For system voltages up to and including 300 kV there are several installations of controlled reactor switching and capacitor bank switching using three-pole operated mechanically staggered circuit-breakers. In cases where the load configuration (electric and/or magnetic

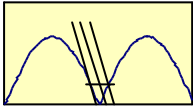

circuit) allows for combined controlled opening and closing some of these three-pole operated, mechanically staggered circuit-breakers are controlled at both opening and closing.

Based on the collected data the following approximate distribution can be calculated:

- Shunt capacitor energising and/or de-energising 64 %
- Shunt reactor energising and/or de-energising 17 %
- Transformer energising only or energising supported by controlled de-energising 17 %
- Line energising (uncompensated or shunt reactor compensated) 2 %
- Combined controlled opening and closing of three-pole operated mechanical staggered circuit-breakers 7 %

Prior to around 1995 installations were very limited due to the relative immaturity of the technology. Since the late 1990's installed numbers have grown rapidly as controlled switching capabilities have been incorporated into modern, flexible digital relay technologies. Today the use of controlled switching in applications such as capacitor and reactor switching is routine and developments are focussed in the more complex areas such as transformer switching.

Whilst some early controller installations proved problematic the overall feedback on properly applied controlled switching is good.

9 Overall Conclusions

This document demonstrates that there are potential technical benefits to be obtained in applying controlled switching beyond the widely accepted case such as capacitive and inductive switching. As can be seen from the controller survey data applications to date are concentrated in these "conventional" controlled switching applications. In practice almost all switching conditions can, theoretically, benefit from an appropriate use of controlled switching although the cost effectiveness of its application may be questionable. In addition, for some scenarios such as fault interruption and uprating, there remain technological and acceptance barriers to the widespread use of controlled switching at this time. Nevertheless, with the rapid advances in the use of digital equipment for control and protection functions, it can be foreseen that sophisticated CS algorithms will become more widely, and cost effectively, available in the coming years. This is likely to lead to an increase in its use in all applications.

It has been shown that there are a variety of methodologies already available for the controlled switching of transformers. The basic principle of all of the methodologies is to choose a closing instant, taking into account the residual flux of the core, such that inrush transients are minimised. These methodologies vary in their complexity but can all significantly reduce transient inrush stresses on the transformer and mitigate system effects such as TOV's. In any specific case the choice of methodology can be made on the basis of the degree of mitigation required and the availability, cost and sophistication of the necessary equipment. Further work is underway to refine these techniques by confirming the assumption that the residual flux does not decay over long periods.

Interruption of fault currents is normally required to be as fast as possible thereby placing very onerous timing limitations upon any controlled switching system introduced for this purpose. A method has been identified for a very rapid (few ms) evaluation of the fault

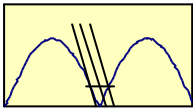

conditions such that no significant additional delay is introduced other than that required to target an optimal contact separation instant. Whilst this has yet to be applied in practice it presents a possible means of reducing circuit-breaker wear in applications where accumulated fault interruption is a life limiting parameter. Providing that the controller is acting as a supplement to the protection rather than an integral part of it no major protection issues are foreseen.

Load interruption, again targeting reduced interrupter wear, is much more straightforward to apply and has potentially greater benefits for heavy load switching applications such as generator circuit-breaker operating to a daily shift pattern.

Interruption of purely series compensated lines is a complex scenario requiring case by case assessment however the most extreme overvoltages can be eliminated with careful consideration.

The main problem associated with retro-fitting controlled switching is obtaining sufficient knowledge of the circuit-breaker characteristics. Nevertheless, successful applications have been reported on the basis of site measurements and monitoring alone. To date retro-fitting of controlled switching has been mainly for the more “robust” cases where some uncertainty can be accepted e.g. reactor de-energisation with a large target window and a tolerance of occasional poor targeting. Work is ongoing to derive more robust, in service, assessment techniques for the suitability of pre-existing circuit-breakers however there is little that can be done practically to cater for a circuit-breaker with unsuitable characteristics (mechanical stability, RDDS etc).

Finally, the potential use of controlled switching for uprating i.e. an increase in rated voltage, rated current or performance class by avoidance of critical conditions, has been clearly demonstrated in technical terms. Nevertheless, it is clear that the major concern in relation to uprating is not the technical ability of the equipment but the reliability and the consequences of mal-operation. In cases of this type mal-operation of the controller may result in operation of the circuit-breaker beyond its proven strength & capability and hence failure. For this reason any controller/circuit-breaker combination used to achieve an uprated performance must be fully tested as a system for all critical duties and must be the subject of a thorough reliability analysis to demonstrate that its potential failure rate does not significantly differ from that of a “fully rated” alternative. This is a very onerous requirement and may remain a barrier to uprating applications for the foreseeable future.

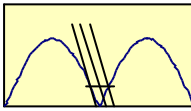

10 References

- [1] CIGRE WG 13.07, Controlled Switching of HVAC Circuit-breakers – Guide for application, Part 1: ELECTRA, No 183, April 1999, pp 43-73. Part 2: ELECTRA, No 185, August 1999, pp. 37-57
- [2] CIGRE WG 13.07, Controlled Switching of HVAC Circuit-breakers – Planning, Specification and Testing of controlled switching systems, ELECTRA, No 197, August 2001 (with full text on the CIGRE Web page)
- [3] CIGRE WG A3.07, Controlled Switching of HVAC Circuit-breakers – Benefits of Controlled Switching (to be published in 2004)
- [4] Brunke, J.H., “Elimination of Transient Inrush Currents When Energising Unloaded Power Transformers,” Doctoral Dissertation No. 12791, ETH Zurich 1998.
- [5] Brunke, J.H., Fröhlich, K.J., "Elimination of Transformer Inrush Currents by Controlled Switching, Part I", IEEE Transactions on Power Delivery Volume 16, number 2, April 2002, pp. 276-280.
- [6] Brunke, J.H., Fröhlich, K.J., "Elimination of Transformer Inrush Currents by Controlled Switching, Part II", ", IEEE Transactions on Power Delivery Volume 16, number 2, April 2002, pp. 281-285.
- [7] Moraw, G., et al, “Point-On-Wave Controlled Switching of High Voltage Circuit-Breakers,” CIGRE paper 13-02, pp. 1-6, 28 August-3 September 1988.
- [8] Holmgren, R., Jenkins, R.S., Riubrugent, J., “Transformer Inrush Current,” CIGRE paper 12-03, CIGRE Paris, pp. 1-13, 1968.
- [9] Mercier, A., Portales, E., Filion, Y., Salibi, A., “Transformer controlled switching taking into account the core residual flux, a real case study”, CIGRE 2002 Conference, 13-201 report.
- [10] Ito, H., Tsutada, H., Hirai, T., Kohyama, H., Kamei, K., Sasaki, K., ”Controlled Energisation of Transformers Taking Account of the Residual Flux”, Proceedings of 2002 National Convention, IEE of Japan.
- [11] Pörtl, A., “Synchrones Abschalten von Kurzschlüssen mittels Hochspannungsleistungsschaltern und Generatorschaltern, Doctor Thesis, University of Technology Vienna, Nov. 1997.
- [12] Poeltl, A., Fröhlich, K., “Two new methods for very fast fault type detection by means of parameter fitting and artificial neural networks“, IEEE Transactions on Power Delivery, Oct. 99, Vol. 14, No. 4, pp.1269-1274
- [13] Poeltl, A., Fröhlich, K., “A new algorithm enabling controlled short circuit interruption”, submitted to IEEE Transactions on Power Delivery, for publication.
- [14] CIGRE TF13.00.1, “Controlled Switching, A state-of-the-art Survey”, Part 1:ELECTRA No.162, pp.65-96, Part 2: ELECTRA No.164, pp.39-61, 1995
- [15] High-voltage alternating current circuit-breakers –Inductive load switching. CEI/IEC 61233: 1994.

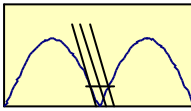

-
- [16] U. Krüsi, U., Fröhlich, K., “Model Based Determination of Circuit-breaker Characteristic for Controlled Switching”. Proceedings of IASTED Int. Conf. on Modelling, Identification and Control, Innsbruck, Austria, 2, Paper Nr. 324-131, pp. 931-936, February 2001.
- [17] Krüsi, U., Fröhlich, K., “Controlled switching – suitability check for already-installed HVAC circuit-breakers”. IEEE/PES Transmission and Distribution Conference and Exhibition 2002: Asia Pacific, Yokohama, Japan, pp. 813-817, October 6-10, 2002.
- [18] Krah, J., “Modelling approaches for audio frequency power transformers”. Royal Institute of Technology, Stockholm. 2003.
- [19] Anderson, P.M., Farmer, R.G., “Series Compensation of Power Systems”, PBLSH, Inc., Encinitas, CA, 1996
- [20] CIGRE WG 13.02 “Interruption of small inductive currents” Chapter 5. Electra No. 133 and No. 134
- [21] Habedank, U., Trapp, N., Schmidt, H.P., Kunze, T., Carreau, D., Kopejtkova, D., Leu, C., Noack, F., “Controlled switching of unloaded transformers – Application with 245/15/15 kV step-up transformer” CIGRE session paper 13-110, 1998.
- [22] Portales, E., Bui-Van, Q., “New Control Strategy of Inrush Transient during Transformer Energisation at Toulustouc Hydropower Plant using a Double-Break 330-kV Circuit Breaker”. IPST New Orleans conference, Sep 28 - Oct 2, 2003 Session 9b: Transformers, Inrush Transients, and Ferroresonance.,

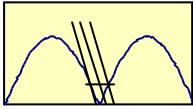

Annexe 1: Influence of protection arrangements on controller application

Any application of controlled switching must take account of the substation configuration into which it is introduced. For simple shunt connected loads reactors or capacitors this is straightforward. However, where controllers interact with protection systems or are required to control multiple loads the situation can become very complex. This annexe provides some brief examples of these considerations.

Case 1

For a breaker-and-a-half configuration with a line and a transformer connected to the central circuit-breaker (a configuration which is usual in transmission system) the requirements for switching the line are very different from those for the transformer. Manual closing of the line requires the controller to cater for the trapped charge on the line whilst transformer operation requires the controller to cater for flux remanence in the transformer core. The controller and associated control scheme must be sufficiently sophisticated to identify the intended action and act accordingly.

Case 2

Connected the circuit-breaker may trip for a fault on either line. The controller must be able to cater for the various trapped charge scenarios that might be experienced and modify its re-closure timing accordingly.

Case 3

For a breaker-and-a-half arrangement with two lines simultaneous faults on both circuits of a double circuit line will result in trapped charges which could be different in each circuit. This places an onerous requirement on the controller of the shared circuit-breaker.

Figure 33. provides an illustration of the complexity of integrating controlled switching equipment into substation control and protections schemes.

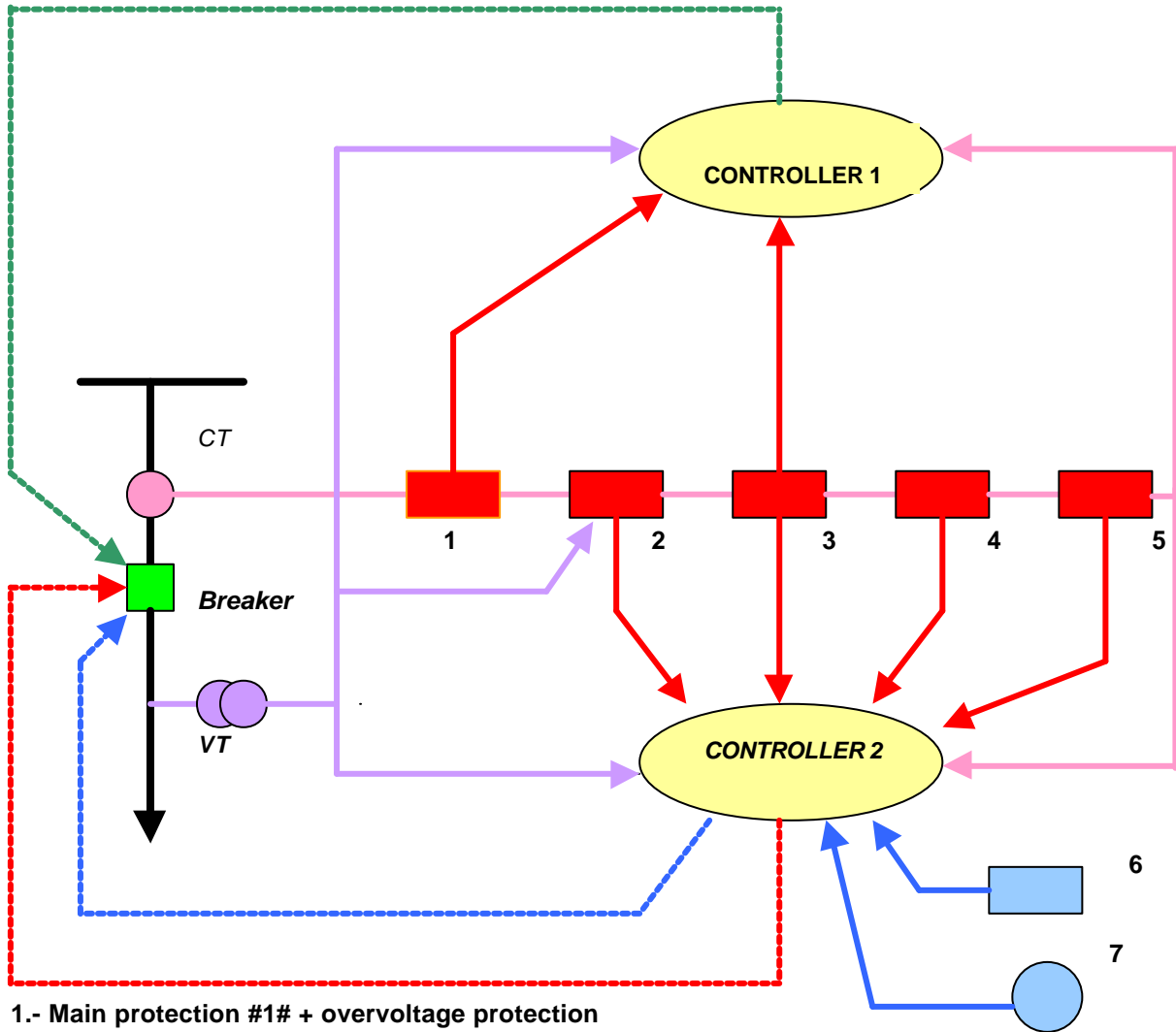
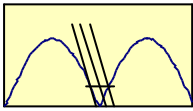

- 1.- Main protection #1# + overvoltage protection
- 2.- Main protection #2#
- 3.- Busbar protection
- 4.- Breaker failure protection
- 5.- Remote trip
- 6.- Recloser
- 7.- Manual closing command

- Trip command to breaker (breaker coil #1#)
- Trip command to breaker (breaker coil #2#)
- Close command to breaker
- Trip command to controller
- Close command to controller
- Voltage signal
- Current signal

Figure 33. An example of controllers integrated in substation control and protection schemes