

406

HVDC Converter Transformers

**Design Review, Test Procedures,
Ageing Evaluation and Reliability in Service**

**Joint Working Group
A2/B4.28**

February 2010



JWG A2/B4.28

HVDC Converter Transformers Design Review, Test Procedures, Ageing Evaluation and Reliability in Service

Members

Milan Saravolac (FR) (Convenor), Gilson Machado Bastos (BR), Narinder S. Dhaliwal (CA), Sergio E. Santo (BR), Thomas Freyhult (SE), Yanny H. Fu (NL), Jan Hajek (SE), A.C. Hall (UK), Peter Heinzig (DE), Ugo Piovan (IT), Vijay Prasher (IN), Shirasaka Yukiyasu (JP)

Corresponding Members

Michael Bridger (NZ), Peter W. Christensen (DK), Roger Cormack (ZA), John F. Graham (BR), Carlos Peixoto (BR), Liu Zehong (CN)

Copyright © 2010

“Ownership of a CIGRE publication, whether in paper form or on electronic support only infers right of use for personal purposes. Are prohibited, except if explicitly agreed by CIGRE, total or partial reproduction of the publication for use other than personal and transfer to a third party; hence circulation on any intranet or other company network is forbidden”.

Disclaimer notice

“CIGRE gives no warranty or assurance about the contents of this publication, nor does it accept any responsibility, as to the accuracy or exhaustiveness of the information. All implied warranties and conditions are excluded to the maximum extent permitted by law”.

ISBN: 978- 2- 85873- 093-3

CONTENTS

Section	Description	Page
	Summary	3
1	Introduction	3
2	Failure Survey and Analysis	4
2.1	Failure Description	7
2.2	Failure Survey Discussion	14
3	Guidelines for Conducting Design Reviews for HVDC Converter Transformers ...	19
3.1	System Data	20
3.2	Insulation Design	21
4	Review of Test Requirements	22
4.1	Polarity Reversal	22
4.1.1.	<i>Influence of Oil Conductivity and Polarization Time on PR</i>	24
4.1.2.	<i>Polarity Reversal During DC Line Faults</i>	26
4.1.3.	<i>Investigation of Possible Improvements of the PR Test</i>	29
4.1.4.	<i>Present Knowledge About Oil Electrical Conductivity</i>	30
4.1.5.	<i>Recommendations Regarding the PR Test</i>	31
5	Conclusion	31
6	Bibliography	32
	Appendix	33

SUMMARY

This is a report of the CIGRE JWG A2/B4-28, which has been initiated in order to continue CIGRE activities on looking into performance and reliability in service of HVDC Converter Transformers.

Findings of the reliability studies covering the period from 1971 to 2009 are presented in the report (the last two surveys show an encouraging decrease in the failure rate). An extract from the Design Review Guide is included as well, focusing on the system data (both AC and DC) and specific aspects of the insulation design. The JWG believes that the Design Review Guide which is based on the existing document produced by the CIGRE WG 12.22 will provide a useful tool for ensuring higher reliability of HVDC Converter Transformers in service.

The JWG reviewed existing standard test specifications while placing an emphasis on the Polarity Reversal (PR) test and the effect of the oil conductivity and polarization time with a view of representing the real service conditions. A summary of the analysis is presented in the report, indicating that if an oil of lower conductivity (e.g. $\sigma = 10^{-14}$ S/m) is used during the test and an oil of higher conductivity (e.g. $\sigma = 10^{-13}$ S/m) is used in service, then the PR test will not be effective as the dielectric stress during the test would be lower than in service. The test voltage, 1.25 times higher than in service, would correspond to a maximum dielectric stress equal to only 36% of the stress that would be experienced in service.

Even though a possible improvement has been identified, the JWG concluded that the existing test should not be modified at this stage due to the logistical and practical constraints. At the same time the JWG recommended that the priority should be assigned to measuring oil conductivity throughout the transformer lifecycle and evaluating the effect of the oil conductivity during the design and design review stage. Further CIGRE activities were recommended in this respect.

KEYWORDS

HVDC, Converter Transformers, Reliability Survey, Design Review Guide, Test Specifications, Polarity Reversal, Oil Conductivity

1. INTRODUCTION

Every year, SC B4 (AG B4.04) collects reliability performance data on HVDC systems in commercial service. The information is compiled and presented at the CIGRE Paris biennial technical sessions and is used for planning, design, construction and operation of HVDC systems.

A concern with regards to reliability of HVDC converter transformers was raised during the WG B4.04 technical presentation at the CIGRE 2000 meeting. Following this, a Joint Task Force (JTF) B4.04/A2-1 "Analysis of HVDC Thyristor Converter Transformers Performance" was established. The JTF first proceeded with a survey, by directly contacting the utilities using HVDC systems. The purpose of the survey was to collect up to date failure information on the converter transformers. The results of the survey indicated that the converter transformer failures were the most significant contributor to the forced energy unavailability (FEU), even though the major failures were only confined to a few projects. The JTF published its reports in 2004 in ELECTRA No.212 [1] and the CIGRE Brochure No.240 [2].

The JTF B4.04/A2-1 raised the following issues in its report.

- The importance of performing dielectric tests in a specific sequence
- Whether or not the PD acceptance level should be further reduced from < 300 pC
- Test procedure of the AC applied voltage test on valve windings with partial discharge measurement
- Method of determination of harmonic losses and extra losses caused by DC bias current
- Should the temperature rise test become a routine test and should its duration be extended
- What kind of acceptance criterion of the DGA results should be used for temperature rise test
- Method of determination of winding hot spot temperature rises and the use of fiber optic technology
- The necessity and condition of performing oil flow electrification test

Due to these concerns the SC B4 proposed initiation of a new A2/B4 JWG with a recommendation to continue activities in this respect, while focusing more on improving the design review process and reviewing the standard test procedures with a view to ensure higher reliability in service, so that HVDC remain to be valid and reliable alternative to the modern HVAC systems.

Following the inauguration in 2004, the new JWG A2/B4-28 quickly converged to an agreement that the highest priority should be placed on the design review guide as it was believed that this document would provide a solid platform and effective tool for reviewing specific aspects of HVDC applications and interactions between Converter Transformers and associated systems, both AC and DC alike. It has been decided to base this document on the existing design review guide created by the CIGRE WG 12.22, which was published in the CIGRE Brochure No. 204 in 2002 [3], while expanding on it further in order to address specific aspects associated with the HVDC Converter Transformer application, service requirements and electrical environment.

2. FAILURE SURVEY AND ANALYSIS

The performance of HVDC converter transformers was first reviewed by JTF 12/14.10. The JTF 12/14.10 surveyed all the HVDC systems operating from commissioning up to 1990. For the purpose of the survey, the failures were defined as actual and preventive. A failure was considered to be actual, if removal of a unit from service was required due to the damage of the active part. A failure was considered as preventive if the unit did not actually fail but was taken out of service to repair active parts following diagnostic testing such as dissolved gas-in-oil analysis (DGA), high insulation power factor, or failure of similar unit(s). Apart from the general pertinent data, a description of the failure was requested, together with the apparent cause(s) as suspected by the utility and/or by the manufacturer and the relation, if any, with the factory type/routine tests performed on that unit. The survey did not cover external bushing flashovers related to pollution.

The JTF 12/14.10-01 published in 1994 a report in ELECTRA No. 155 [4] summarizing the performance of HVDC systems up to 1990.

Table 1. Summary of transformer failures (1972-1990)

Category ->	A Bushings	B Valve Windings	C AC Windings	D Static Shields	E LTC	F Core & Magn Shields	G Internal Conn.
Mechanical 11	3- Itaipu	3-Itaipu		2_Dumr 1-Hamil	1-Comerf 1-Oklaun		
Dielectric 13 + 2P	1- Blackw 1-IFA 2P-IFA	4-Itaipu	5-Itaipu	1-S.Butte			1-CU
Thermal 5+35P			1-Eel Riv 11P-Eel Riv	4-Eel Riv			24P-Itaipu
Ind. Curr. 2+51P						2-Nelson 1P-Nelson 2P-Hamil 48P-Itaipu	
Operator 1					1-Inga		
Unknown 1	1-PIE						
Total 33+88P	6+2P	7	6+11P	8	3	2+51P	1+24P

A recommendation was made that following aspects should be covered in detail in the design review prior to fabrication:

- Valve side bushings
- Currents induced in the core
- Harmonic stray fluxes
- Short circuit forces
- Winding turn to turn insulation
- Winding cables inter-strip insulation
- Load tap changers
- Static shields

In addition, the JTF 12/14.10 also investigated the relationship between test and service stresses as a function of conductivity ratio for HVDC converter transformers and smoothing reactors [5]. The JTF 12/14.10 recommended that duration of the long term dc test should be extended to two hours and that one hour applied ac test should be performed with partial discharge (PD) measurement. These recommendations were eventually incorporated in the new version of the IEC Standard 61378-2 issued in 2001.

As the continued SC B4 reliability survey pointed to a further increase in FEU due to the HVDC Converter Transformer failures a new JTF (B4/A2) was established at the CIGRE 2000 Session with a mandate to analyse the system performance data collected annually with an objective to identify dominant causes underlying the growing transformer failure rate.

The new JTF B4.04/A2-1 first proceeded with a survey by directly contacting the utilities using HVDC systems.

Table 2. Summary of the transformer failures from 1991 to 2002.

Summary of Transformer failures 1991 to 2002							
Category ->	A Bushings	B Valve Windings	C AC Windings	D Static Shields	E LTC	F Core & Magn. Shields	G Internal Conn.
Mechanical 9+8P	1-H.Hnsh1 1-Itaipu 1-PIE-Ex 1P-Itaipu 1P-F.Skan		1-Radsn		2-C.C. 2-Kontek 2P-F.Skan 1-Radsn	1P-K.Skn2 1P-NR2 1P-PIE-UG	1P- Skagrk
Dielectric 36+10P	1-Skagrk 2-Gezhba	3-Chnd-Pg 2-Chatgy 1-NR1 6-NR2 1-Meanum 2-Itaipu 10-R.Dadri 4P-Chatgy	1-NR1 1-R.Dadri 1-R.Dadri*		1-F.Skan 1-Gzhba 1-R.Dadri	1-Haenam* 2P-K.Skn2 1P-Vyborg	1-C.C. 3P-C.C.
Thermal 2+3P		2-NR2				1P-C.C. 2P-SwPol	
Ind. Curr. 1+3P		1-H.Gate 2P-H.Gate		1P-K.skn2			
Operator 1					1-IPP		
Unknown 7+1P	1-S.Pond 1-V.Smith 1P-Madws		1-S.Butte	1-PIE-Upg	1-Eel R 1-Haenam 1-Welch		
Total 56+25P	8+3P	28+6P	5+0P	1+1P	12+2P	1+9P	1+4P

*Failure involved more than one category

The survey also included failure descriptions provided by the reporting systems. The JTF B4.04/A2-1 submitted its report [2] in 2004 with a recommendation for a new JTF or JWG A2/B4 to be formed to further investigate the issues mentioned above and that the scope should include consideration of detailed test recommendations to relevant IEC and IEEE committees.

The JWG A2/B4-28 conducted three transformer failure surveys covering transformer failures from 2003 to 2008. The survey questionnaire was similar to that used by JTFB4.04/A2-1. In the first survey conducted in 2005, a total of 14 projects responded. There were 12 actual failures in the period 2003 to 2004, out of which 11 failures were associated with the valve windings and the remaining one with the line (AC) winding. In addition, there were 45 preventive failures reported. In the second survey conducted in 2007, a total of 29 systems responded. There was a total of 15 actual failures in 2005 and 2006. In addition there were 21 preventive failures reported.

The third survey was conducted in Feb 2009, a total of 34 projects responded. There were 9 actual failures and 8 prevent failures reported in 2007 and 2008.

Table 3. - Summary of failures reported in 2005, 2007 and 2009 surveys

Summary of Transformer Failures 2003-2008							
Category ->	A Bushings	B Valve Wdgs	C AC Wdgs	D Static Shields	E LTC	F Core & Magn. Shields	G Internal Conn.
Mech 1	1-BassLink						
Dielect 29+14P	4P- Longqu	6 – Rihand 6 – Chan.Ph 5 - Itaipu 1P-Skgrk 3 1-NR2 2P-Itaipu	1 – NR1 1P-NR1 2P-NR2 1-Itaipu 1-CU		1P- 3G_Chang 2P-3G- Guang 1-Skg3 1-Vyborg		1P-Chezu 4-Chand BtB 2-Vizag I
Thermal 5+56P	2P-GezNanq 2-Lingbao 1-GG2 1-Nanq	2P-NR1 2P-NR2	1P-TSQ		1P-Baltic 6P-SwePol 1P- 3G_Chang	4P-EGAT 4P-TNB 1P-RTE	1P-Zhengp 7P-Vizag1 7P-Sasram 13P-Chand BB 1-TianGuan 1P-NR1 2P-NR2 1P-3G_G
Ind. Curr 0+1P							1P-SwePol
Operator 1+0P					1-K Skan 1		
Unknown 0+2P						1P-Apollo	1P-Apollo
Total 36+73P	5 + 6P	18 + 7P	3 + 4P	0 + 0P	3+ 12P	0 + 10P	7 + 35P
* Failure involved more than one category							

Table 3. shows the failure data for the surveys from 2003 to 2008. There was a total of 36 actual failures and 73 preventive failures.

2.1. Failure Description

All reporting systems were requested to submit descriptions of the failures, the outage time and the corrective action taken. The following describes the failures by categories.

2.1.1 Bushings (5 Actual + 6 Prevent)

Three Gorges-Longquan - 4 Prevent

SF6 gas leak in the bushing. One unit was replaced with spare and 3 units were repaired. The outage time for replacing transformer was 48 hours.

Gezhuba - Nanqiao: 2 Prevent

The bushing showed signs of overheating during overload test. The bushings were changed. The failures were one at each end on the link.

Outage time: 121 hours

Lingbao BtB: 2 Actual failures

Bushing failure on the valve winding side.

Outage time: 288 hrs.

The last shielding of valve bushing possibly did not contact with ground reliably, an amount of space charge accumulates, leading to discharge. On Apr. 24, 2007 @ 04:24, the valve side bushing of phase C (Ya bushing, voltage is 220kV) exploded, the “grounding current protection of protection and control system”, “gas protection”, “pressure release” protection operated correctly.

Outage time: 261 hours

Gezhuba - Nanqiao: 1 Failure

NanQiao station Pole II phase C tripped because of the main tank gas relay acted but pressure relief not acted in 21, Dec,2008. After the trouble unit was disassembled, the internal connection between winding and bushing 2.1 was found damaged. The damaged transformer was transported to local manufacturer for repair. After investigation, it was concluded that the failure was caused by bushing quality itself.

Outage time: 91.5 hours

Gui - Guang 2 - 1 Failure

One Y-Δ Converter transformer AC system side bushing blasting during operation, and the pole tripped. The unit was replaced with spare.

Outage time: 177 hours

Bass Link : 1 Failure

There was a bushing failure due to mechanical stress fracture at the change in diameter behind the oil flange. Fracture in RIP propagated by thermal cycling due to variable power transfer of interconnector. Failure occurred when fracture compromised voltage withstand within bushing flange

Outage time: 200.65 hours

2.1.2 Valve Windings (18 Actual +7 Prevent)

Rihand-Dadri - 2 Actual (2003-2004)

The failure has been caused by an inter turn fault due to the weakening of inter strand insulation between parallel conductors. Meanwhile the transformer windings have been strengthened to the maximum extent possible without compromising the design parameters like impedance, etc. The root cause of failure was still under investigation at the time of reporting.

The units were replaced with spares in 39 hours.

Rihand Delhi: 4 Actual (2005-2006)

Four transformers failed in 2006. Three faults on the delta valve winding one on star valve winding. No exact cause for failure is known.

Outage time: 72 hours for three failures as spare was available.
1152 hours in for the fourth failure (no spare).

Chandrapur- Padghe - 4 Actual (2003-2004)

Four units failed due to turn to turn fault in the valve windings. The root cause of failure was still under investigation at the time of reporting. The units were sent to factory for repairs.
Outage times were 4359, 7464 and 7464 hours when spare was not available.
Outage time was 221 hours when spare was available

Chandrapur - Padghe : 2 Actual (2005-2006)

One transformer failed at Chandrapur and was replaced by spare.

Outage time: 264 hours

One transformer failed at Padghe, no spare was available.

Outage time: 5760 hours.

Itaipu - 5 Actual + 2 Prevent failures

Five units failed due to fault in the valve windings. The units were repaired on site. There are 4 spare units on site and the spare can be placed in service in 4 days.

A rebuilding program has been started to replace the old transformers with rebuilt units. The new units have redesigned windings.

Outage time: 24 hours each

Nelson River 1: 2 Prevent

2005-Transformer was over 30 years old and was gassing

2006- Replaced over 30 years old transformer that was gassing

Outage time: All outages were planned ahead of time

05-199 hrs

06-541 hrs

Nelson River 2: 1 Actual + 2 Prevent

2005-Replaced 2 units which had been designated for replacement due to generic fault.

Outage time: All outages were planned ahead of time

05-181 hrs

05-139 hrs

2007- At Dorsey, converter transformer T31S failed due to fault in the valve winding. The transformer was replaced with the spare transformer.

The forced outage time was 576.37 hours

Skagerrak 3: 1 Prevent

Changed transformer because of possibility of Copper Sulphide failure as the oil was found to be corrosive.

Outage time: 336 hours

2.1.3 AC Windings (3 Actual + 4 Prevent)

Nelson River Bipole 1 - 1 Failure

The unit failed due to turn to turn fault near the neutral of the AC windings. This unit was over 30 years old.

The unit was replaced with spare. Total outage time was 689 hours. The extended outage time was required due to compact design of the buswork. Both the old and new units have to be disassembled before moving.

Nelson River Bipole 1 - 1 Prevent failure

This unit had been gassing for a number of years and had been kept in service using on-line degassifier. As the unit was over 30 years old it was replaced with spare and the not repaired. Total planned outage time was 238 hours.

Nelson River Bipole 2 - 2 Prevent failures

These transformers were part of the stage 1 equipment and had been known to have conductor insulation failure problems. The units had been gassing for a few years and were replaced with spare units. Repaired were found to be not cost effective.

Itaipu: 1 Actual failure

Unknown cause.

Outage time: 24 hours

CU PROJECT: 1 Failure

Transformer had a fault in tap changer winding on one phase or in tap changer winding leads. Fault currents damaged other windings. Arc gasses/products apparently initiated a fault to ground inside the tank to 1 ac-side bushing.

The transformer was manufactured in 1976 and was in service for 30 years.

Outage Time: 247 hours

Tian-Guang: 1 Prevent Failure

One transformer was replaced by the spare transformer since the Dissolved Gas Analysis (DGA) Problem. The fault is suspected to be in the AC winding.

Outage time: 49 hours

2.1.4 Load Tap Changer (LTC) (3 Actual + 12 Prevent)

Baltic Cable: 1 Prevent

Due to high number of tap changer operations the oil valve was clogged because of dirty oil. The link tripped on low oil pressure. On line oil filtering system has been installed in order to reduce the oil contamination.

Outage time - 39 hours.

SwePol: 6 Prevent

All 6 units have been gassing since the very beginning. As was stated in the last survey a spare unit was ordered and the unit with the highest gassing rate was exchanged for the new spare in October – November 2004. Deficiencies were found in the OLTC selector switch contacts, however this was at the time and still is not considered to be the only fault. This led to the decision to change the contacts to new silver plated ones in all units in both stations in the autumn 2005. A stiffening of the mounting of the OLTCs were made at the same time as a precaution to avoid fretting on the contacts due to vibrations. At the same time the transformer oil was degassed and a passivator against sulphur corrosion was added. Normal revision of the OLTCs was also made during the outage time (after about 90,000 operations).

Outage time: 309 hours

3G-Changzhou: 2 Prevent Failures

Abnormally high gassing in the OLTC. The transformer was replaced by a spare unit.

Outage time: 72 hours

In January 2007 outage, the repaired Y/Y transformer was put into service again to test the operation capability. In February the transformer C2H2 increased beyond the Chinese standard. In 2008 February, the transformer was replaced by spare one.

Outage time: 72 hours

3G-Guangdong; 2 Prevent

Abnormally high gassing in the OLTC. The transformer was replaced by a spare unit..

Outage time: 72 hours each.

Skagerrak 3: 1 Failure

Phase to phase flashover in the tap changer diverter switch of a converter transformer in Denmark. The transformer was sent for repair. All three load tap changer windings and the diverter switch were replaced.

Outage time was 7366 hours

Vyborg: 1 Failure

OLTC diverter was faulted on phase B, HVCU4, RS (rectifier):. Diverter protection had operated when the OLTC switching occurred.

Outage time: 22.5 hours

Konti Skan 1: 1 Actual Failure

The tap changer was set in manual on the marshalling box in the rectifier, this caused the control of the tap changer to go to local control, when the marshalling box was put back in auto mode, the control remained

the tap changer in local control, when the power was raised the control was swapping between two control modes which resulted in more than 600 tapping orders in one hour, which caused high temperature and overpressure in the tap changer tank, with trip from pressure device. A separation plate on the tap changer cover blew off.

Outage time: 210 hours

2.1.5 Core and Magnetic Shields (10 Prevent)

Thailand Malaysia - 8 Prevent

The core grounding resistor was found to be burnt on one unit. All units were repaired by solidly grounding the core.

RTE-France: 1 Prevent

Contact between magnetic circuits created a hot spot in the tank. The transformer was exchanged with spare. The transformer was repaired on site. A DC voltage test was performed after the repair. After 6 months into service this transformer continued to create gas in oil. It was made an oil treatment one year after the return to service of the transformer. Now, gas in oil is quite stable.

Outage time: 27 hours

Apollo : 1 Prevent failures

Bridge 1 - The transformer was gassing and was taken out for inspection. No fault was found and the transformer was put back in service.

Outage time: 72 hours

2.1.6 Internal Connections (7 Actual + 35 Prevent)

Chezu - 1 Prevent failure

Breakdown of insulation between windings and the tank via pressboard support. Pressboard contamination was suspected and was replaced.

Three Gorges Zhengping - 1 Prevent failure

The gas content was higher than the customer's standard so the unit was replaced.

Sasaram, Chandrapur, Vizag I - 27 Prevent failures

They have had localized overheating on the connection between valve winding and the bushing due to lack of cooling. The problem was noted through DGA. Planned outages were taken to repair transformers. The modification was made to improve the oil flow. All transformers of the same design were repaired on site.

Chandrapur BtB: 4 Actual failures

All failures due to flashover between tap leads. One unit failed twice even after it had been repaired previously. The third unit had been repaired twice before and failed again.

Outage Time: 456 hrs in 2005
423 hrs in 2006

Vizag 1 : 2 Actual failures

The two failures occurred due to flashover between the tap leads. The repairs were made on site. One of the units has since failed twice in 2007.

Outage time: Year 2005 - 360 hours.

Nelson River 1: 2 Prevent failures

2006-Repaired tap lead that was overheating

Outage time: 276 hrs. The outage was preplanned.

Nelson River 2: 3 Prevent

2006-This was one of the new units that was installed the previous year. The unit started gassing shortly after it was commissioned. Detailed inspection showed overheated connections. The unit was replaced with spare and is under repairs.

Outage time: Outage time 67 hours.

SwePol - 1 Prevent failure

The unit has been gassing for long period of time and was replaced after the spare was available. The cause of gassing is still under investigation.

Tian-Guang: 1 Actual Failure

Failure of internal connection between winding and the bushing.

Outage time: 672 hours

Apollo : 1 Prevent failures

Bridge 2 - Due to abnormal gassing level, the transformer was taken out of service and inspected. Arcing marks were found on the bushing connections. Bushing contacts (multi contacts) were removed to be replaced.

Outage time: 72 hours

3G - Guang: 1 Prevent Failure

Transformer was gassing and taken out of service for repairs in Mar 2007 and replaced with spare. The internal connection between winding and bushing was found broken. The unit was repaired and put back in service and is working OK.

Outage time: 72 hours

Nelson River 2: 1 Prevent failure

At Henday, converter transformer T42S was inspected internally and number of hot connections were found. This was a new transformer but has been gassing since the day it was installed. The transformer was replaced with spare and is being repaired. The work was done during regularly scheduled outage.

2.2 Failure Survey Discussion

The failure rate is calculated as follows:

$$FailureRate = \frac{Total\ Number\ of\ Units\ Failed}{\sum (Number\ of\ Units\ in\ Service \times Years\ in\ Service)}$$

Due to insufficient technical data made available to the JWG for the purpose of this analysis it was not possible to determine the actual causes of individual failures as requested by SC B4, nor it was possible to identify some general trends, despite some limited data volunteered by some members of the JWG.

The JWG also did not look into failures attributable to the effect of the corrosive oil as this phenomenon was covered by a dedicated CIGRE WG (A2-32).

Figure 1. shows the Converter Transformers failure rate history based on the combined data of surveys carried out in the following periods:

- 1972 to 1990
- 1991 to 2002
- 2003 to 2004 (reported in 2005)
- 2005 to 2006 (reported in 2007)
- 2007 to 2008 (reported in 2009)

It can be observed in the Figure 1. that following a reduced failure rate in the period from 1991 to 2002, there was a significant increase in the period from 2003 to 2008 as derived from the combined data collected through three individual surveys (2003-2004, 2005-2006 and 2007-2008). However, when the failure rate is shown separately for the three individual surveys reported in the period from 2005 to 2009 (Figure 2.) it can be seen that the main contributor to the increased combined failure rate was that corresponding to the period 2003 to 2004. Following this initial rise the rate was monotonously decreasing through the period 2005-2006 and finally dropped to a level below the rate recorded for the period 1991 to 2002.

This finding is encouraging, indicating a potential effect of the latest version of the IEC 61378-2 standard as well as a strong action that followed an upsurge of the HVDC Converter Transformers caused to a full or a partial extent by corrosive oil.

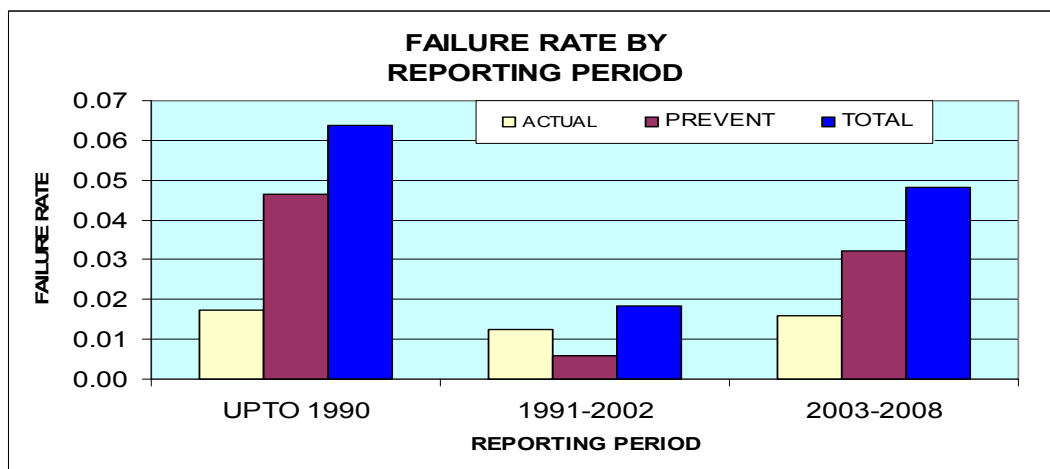

Figure 1. Failure Rate for the period 1972 to 2008 (survey data 2003 to 2008 grouped)

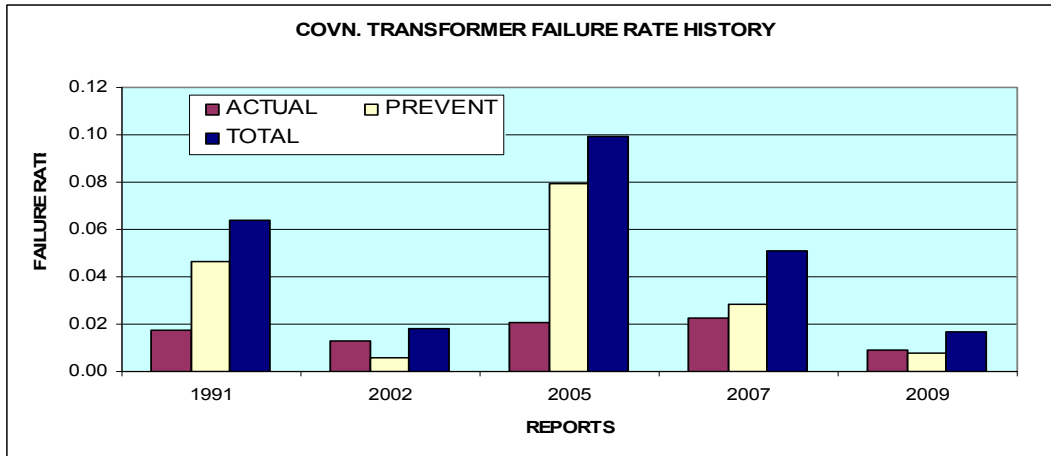

Figure 2. Reported failure rate for the period 1972 to 2009

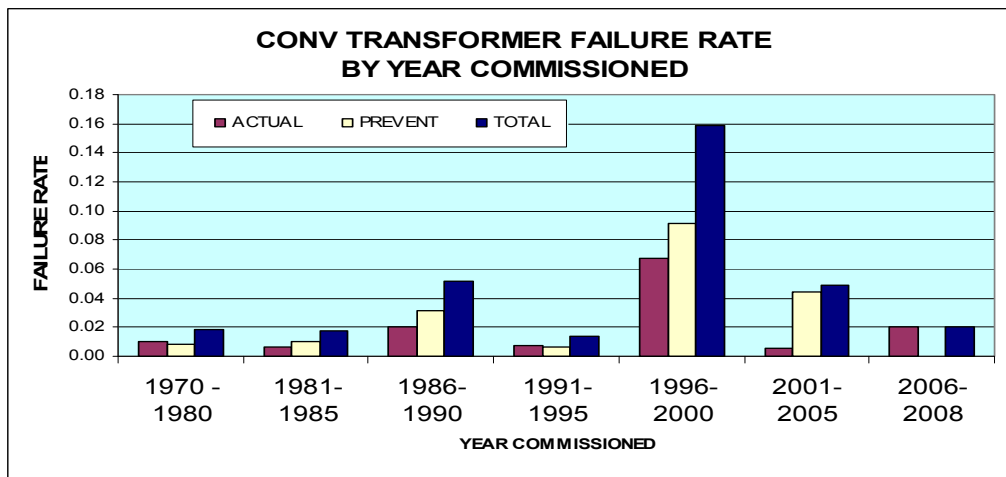

Figure 3. Converter Transformer failure rate by year of commissioning

When the failure rate is plotted against the year of commissioning it can be seen (Figure 3.) that for the systems installed before 1985 the value was low but an increase could be observed for transformers placed in service in the period from 1985 to 1990. It should be noted that this is a period when transformers of ratings of over 300 MVA were installed and a higher DC voltage (500 kV and 600 kV) was first introduced.

The failure rate of the systems commissioned between 1991 and 1995 continued to be low. This is the period when no large rating HVDC systems were installed but only a number of small projects were commissioned.

It can also be seen in the Figure 3. that the failure rate of the systems commissioned between 1996 and 2000 increased again. Most of the systems installed in this period were of higher ratings requiring installation of large Converter Transformers.

The systems installed between 2001 and 2008 presented an increasing number of preventive failures while the number of the actual failures decreased significantly. This phenomenon could be attributed to the following;

- a. Modern transformers are now more closely monitored (e.g. on-line gas monitoring).
- b. Most of the systems are designed with spare transformers being readily available so that when a potential problem occurs the unit can be changed before the actual failure.

Another possible contributing factor to the reduction of the actual failure rate in this period is the effect of the modified IEC Standard (61378-2) issued in 2001.

Figures 4., 5. and 6. show the numbers of failures as a function of the configuration of the winding in the same tank. The winding configurations are defined as follows;

- 1-2 Single phase, two winding (line winding, star or delta valve windings)
- 1-3 Single phase, three winding (line winding, star valve winding & delta valve winding)
- 1-4 Single phase, four winding (line winding, star valve winding , delta valve winding & tertiary winding)
- 3-2 Three phase, two winding (3 phase line windings , 3 phase star or delta valve windings)
- 3-3 Three phase, three winding (3 phase line windings, 3 phase star & 3 phase delta valve windings)
- 3-4 Three phase, four winding (3 phase line windings , 3 phase star valve windings, 3 phase delta valve winding & tertiary winding).

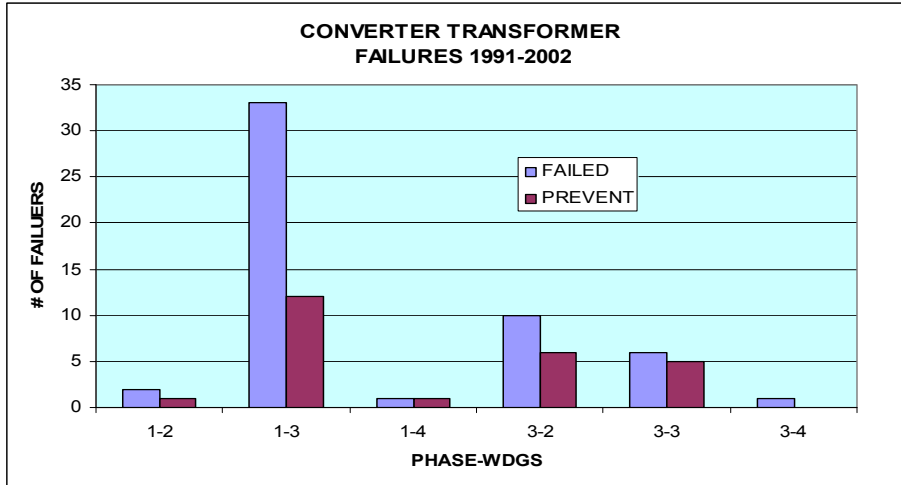

Figure 4. Summary for the period 1991-2002

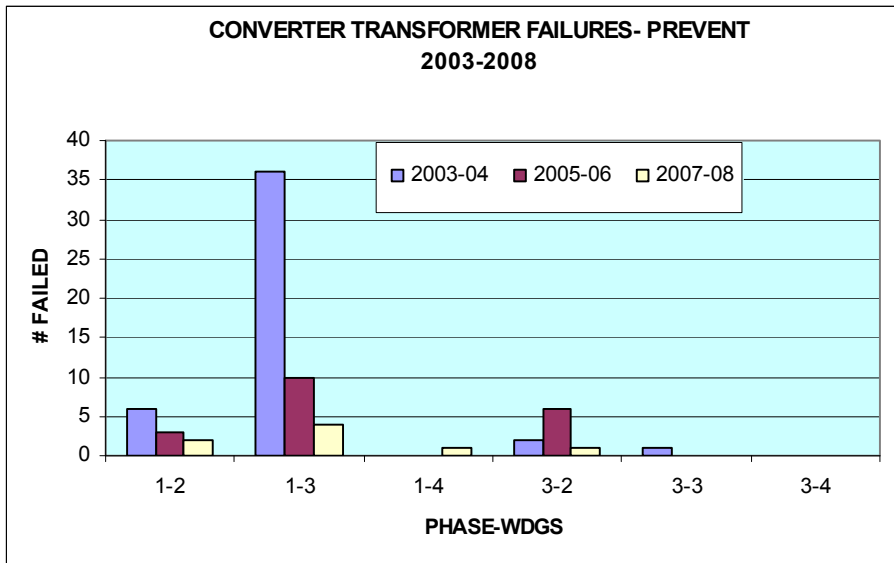

Figure 5. Preventive failures for the period 2003-2008

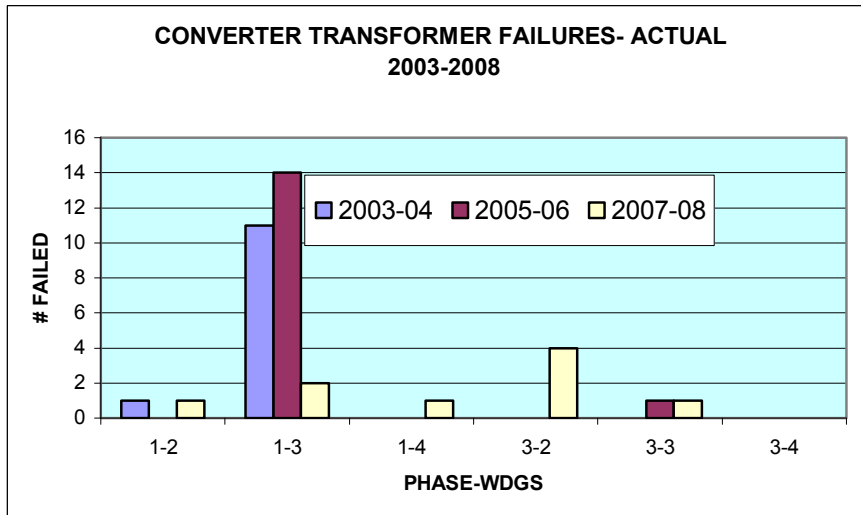

Figure 6. Actual failures for the period 2003-2008

All three figures show that **most failures occurred in single phase units containing line winding and star and delta valve windings**. These transformers were of the ratings 275 MVA and above and installed in the HVDC systems of 500 kV or above. This increased failure rate could be associated with the complex winding, insulation and lead exit design.

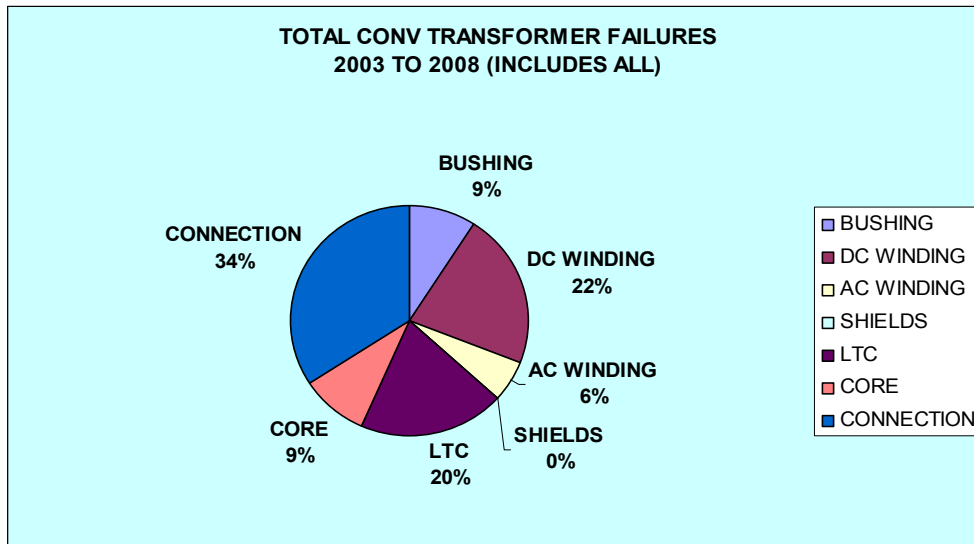

Figure 7. Contributors to Converter Transformer failures including all years of commissioning

Figure 7. shows the total failures (actual and preventive) by components, for the period from 2003 to 2008. This figure includes all the systems that reported **irrespective of the year of installation.**

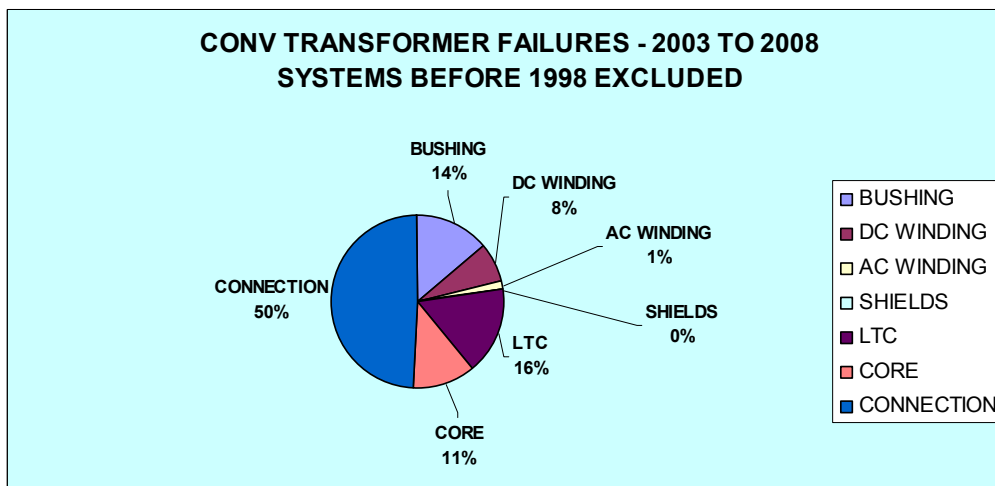

Figure 8. Contributors to Converter Transformer failures excluding years of commissioning before 1998

Figure 8. shows the total failures (actual and preventive) by component for the systems **installed 1998 or later.**

It can be seen in the figure 7.and figure 8. that failures in the connections, valve winding and OLTCs were the most dominant contributors to the failure statistics when all years of commissioning are taken into account while the failure in the connections remained to be the most dominant factor for the systems installed in the last ten years.

While the multiple failures in the valve windings were significantly affected by the quality of oil i.e. the presence of the semiconducting Copper Sulfide resulting from the application of the corrosive oil and the failures in the OLTC could partly be attributed to the transient phenomena associated with the converter operation, the increasing failure rate in the connection could be attributed to the increased design complexity and increasing voltage levels.

Particularly high number of failures in the connections was recorded in the survey conducted in the period 2003-2004 as shown in Figure 9.

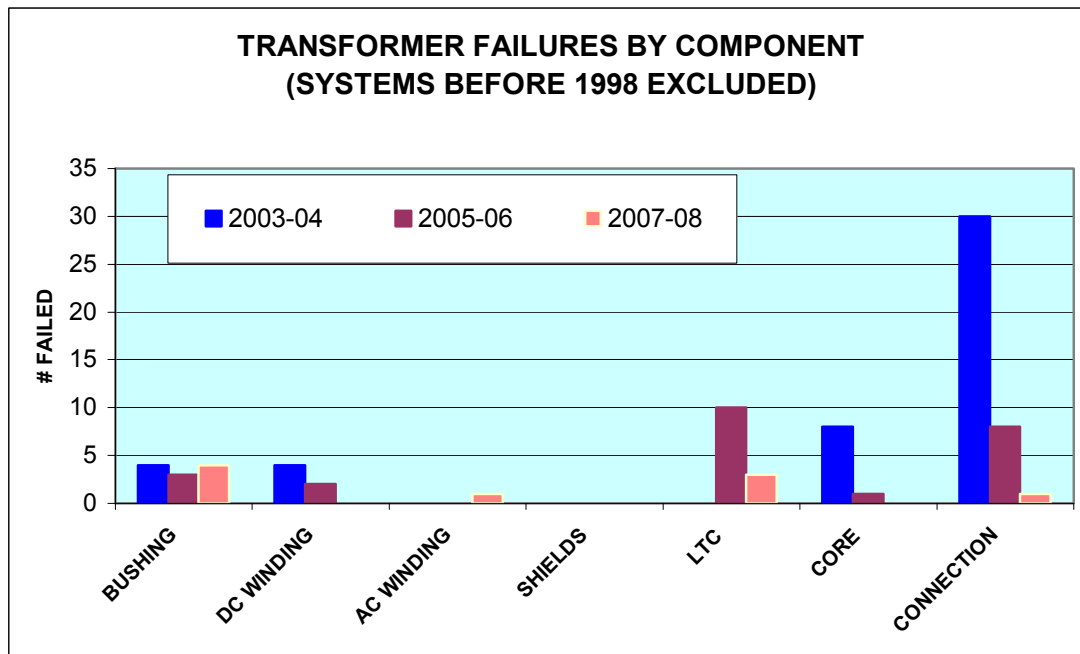

Figure 9. Converter Transformer failures by Component. Systems with the year of commissioning before 1998 are excluded.

3. GUIDELINES FOR CONDUCTING DESIGN REVIEWS FOR HVDC CONVERTER TRANSFORMERS

Subsequent to the inauguration in 2004, the new JWG A2/B4-28 quickly converged to an agreement that the highest priority should be placed on the design review guide as it was believed that this document would provide a solid platform and effective tool for reviewing specific aspects of HVDC applications and interactions between Converter Transformers and associated systems, both AC and DC alike. It has been decided to base this document on the existing design review guide created by the CIGRE WG 12.22, which was published in the CIGRE Brochure No. 204 in 2002, while expanding on it further in order to address specific aspects associated with the HVDC Converter Transformer application, service requirements and operating environment

Failures of the HVDC Converter Transformers usually result in major energy unavailabilities of the substations. It is essential to achieve and maintain a high reliability of the Converter Transformers. It is believed that one way of achieving this is through detailed and rigorous specifications and design reviews, based on a close collaboration between users and manufacturers. These reviews should address specific operating conditions and associated requirements on the transformer design, such as for example higher harmonic contents or transient waveforms.

On the other hand, equipment manufacturers should be able to prove the capability of understanding and controlling design margins and would be required to present relevant design tools and verification/acceptance criteria. For the most of the modern manufacturers this should not present any difficulty.

A design review is a planned exercise to ensure that there is a common understanding of the applicable standards and specification requirements, and to provide an opportunity to scrutinize the design to ensure the requirements will be met, using the manufacturer's proven materials and methodology.

The design review should examine the functionality of the transformer to perform within the specified operating requirements and includes the following considerations:

- Specification requirements,
- System data,
- Environmental data,
- Transformer design,
- Fabrications,
- Inspection and test plan,
- Transportation and installation (when applicable).

When compared with the existing general Design Review Guide created by the CIGRE WG 12.22, which was published in the CIGRE Brochure No. 204 in 2002 [3], most of the HVDC specific aspects and requirements are associated with the System Data and Insulation Design. Due to the limited space for this report these two parts have been extracted for more detailed presentation in the following part.

3.1 System Data

The specified system conditions under which the transformer will be required to operate should be reviewed. These should include:

- (a) AC system voltage variations. The usage of the tapchanger should be examined, indicating the number of anticipated operations per year. The tap range and subdivision needs to be considered. A number of specifications seem to require a very large range but in small voltage steps which can require a tapchanger with more position than in readily available types. The appropriate nominal position and increment needs to be set realistically. The reactive power flow conditions need to be considered because of the effect on the tapchanger switching and voltage regulation.
- (b) AC system frequency variation and voltage transients.
- (c) DC and harmonic system components.
- (d) AC system short circuit capacity including system operating data. Waveforms of s/c current to be established for AC and DC side.
- (e) System switching and transformer protection. The type of transformer protective switching should be described. It is possible that the transformer manufacturer may also want to insist on some particular protection against unbalance or circulating current. The type and application of over-voltage protection should be reviewed. There is a need for a full study of overvoltage protection and calculation of energy absorption because the setting of the insulation coordination and hence the voltage levels are fundamental to the test specification and design of the transformer. The characteristics and location of arrestors on the DC and AC side of the converter transformer and DC bridge are key parts of the system design. The surge arrestors can help limit overvoltage caused by transients. Equally it is important to consider which if any of the surge arrestors are to be used during the testing of the transformer, or if their voltage limiting effect is to be taken into account for the test conditions. Description of the AC system around the DC terminal and associated protection should be provided including contingency scenarios and actions.
- (f) System earthing conditions and grounding DC currents (due to single pole operation). The position and quality of the DC grounding are important for long-line operation and significant bias currents, independent of any geomagnetic currents that can be induced. Typical specifications require accommodation of up to 10 Amperes DC bias current in the neutral of the converter transformer. The

quality and stability of the earthing point connection are a matter of concern. Problems have been reported due to loss of earthing capability due to changes in ground water conditions, galvanic corrosion and high resistance joints leading to poor earthing and ingress of transient voltages through a neutral connection or the equipment grounding terminals. Circulating currents within the earthing and grounding system may be present if care is not taken to consider earthing arrangements because of the very large area covered by the grounding mat for a substation. A review of the earthing of the transformer and possible parallel paths is necessary. Wherever possible the system designers should be involved in this review.

- (g) The system connections to the transformer should be discussed noting that the surge impedance is less for cable and bus connections. This may affect the terminal impedance used during impulse tests.
- (h) High frequency transients. Some system operations such as switching of large capacitor banks, GIS or cables are known to produce fast transients (FTs), or very fast transients (VFTs). These and other possible sources of FTs and VFTs may result in excessive voltages within the transformer. These may generate internal resonances. A high frequency (HF) model of the transformer should be available containing information on the frequency dependent damping characteristics and results of interaction studies for any scenario provided by the system designer. There is a concern that apart from those generated locally by switching, transients may also be injected into the substation by transmission over the DC lines from outside the station due to coupling from other lines and operations at the far end of the line. The protection and filtering of the incoming lines against high frequency transients should be considered carefully.
- (i) Voltage transients. They are caused by valve operation and especially by high firing angle operation and commutation failures. The actual predicted waveforms from the planned valve operation under all extremes of operation should be available. These calculations need to be supported by actual measurements or simulations on the same valve or similar in these operating conditions. Experience has shown that the normal predictions do not properly represent some of the very high frequency transients actually present at site under certain load conditions, particularly when the system is lightly loaded and providing reactive power compensation. The internal design of the transformer however needs to consider how these transients would be accommodated in the transformer or prevented from entering the transformer.
- (j) Current harmonics with defined values for each harmonic order (not just total harmonic distortion (THD) or Eddy Loss Enhancement Factor). In case the transformer has more than 2 windings wound on the same core limb, depending on type of magnetic coupling among different windings, for each harmonic, the phase relationship among the phase currents injected in the valve windings should be provided.

The accuracy of impedance matching should be reviewed with a view of canceling the higher harmonics in the windings.

Note: For more information refer to IEC 61378-3, Clause 9.1.4 [6], transformers with three or more windings wound on the same core limb.

3.2 Insulation Design

The insulation system is exposed to combined AC and DC voltage stresses during service which can not be realized simultaneously in the test field and which are therefore simulated by separate AC, DC and Polarity Reversal tests. The specified test shall ensure that a successfully tested transformer has sufficient insulation strength to withstand the service stresses over its lifetime.

The manufacturer should present an insulation layout drawing. Each major region of the insulation structure (i.e. main gap between windings, shielding and/or ground insulation at winding ends, inner winding to core, outer winding to tank, axially along windings) should be identified with the test or

operating condition which is most critical to its dimensioning and design. A brief summary of the stresses in the critical regions for each test or operating condition should be reviewed.

In this regard, the electric field simulations are recommended. These should cover all test voltages the insulation system is exposed to (AC, DC and PR) in order to ensure that voltage stresses are acceptable taking into account the overall duration of the tests and associated electrical field transients (over the entire range of temperature variation). The manufacturer should present the basis for these calculations:

- Permittivity of materials used,
- Conductivity of materials used,
- Consideration of temperature and field strength dependencies of the material properties,
- Boundary conditions used for electric field simulation.

The manufacturer should demonstrate how the insulation is designed to withstand the imposed stresses, i.e. indicate insulation structure, corresponding stress and resultant dielectric strength:

- Turn to turn,
- Section to section,
- Winding to winding,
- Winding to ground,
- Phase to phase,
- Location of electrostatic plates and shields,
other winding stresses at:
 - Winding nodes *
 - Leads,
 - Due to transferred voltages from other windings.

* Nodes are coil interconnections and changes in winding construction that cause a change in the series capacitance of the winding.

The manufacturer should present information on the range of oil conductivities for which the results of the evaluation of insulation are valid.

4. REVIEW OF TEST REQUIREMENTS

4.1 Polarity Reversal (PR)

The JWG focused on the PR test from the beginning as it was believed that the length of the application of the DC voltage during the test might have not been sufficient for composite insulation systems containing oil of low conductivity to reach its final stationary state and associated distribution and magnitude of the local electric stresses.

Both IEC 61378-2, Ed. 1, 2001 and IEEE C57.129-2007 define the PR and DC test levels as:

$$U_{pr} = 1,25((N - 0,5)U_{dm} + 0,35U_{vm}) \quad (1)$$

$$U_{dc} = 1,5((N - 0,5)U_{dm} + 0,7U_{vm}) \quad (2)$$

Where a factor of 1.25 represents a safety margin in the equation (1).

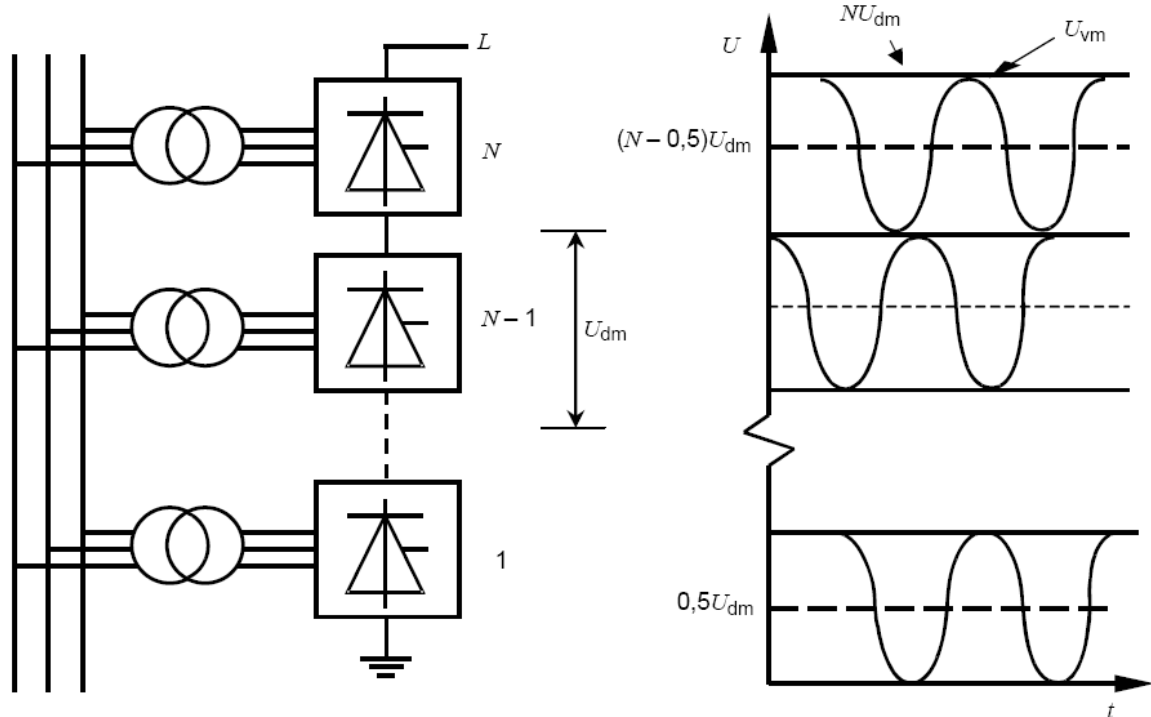

Key

L – Line

t – Time

Figure 10. Explanation of PR test level (from IEC 61378-3) [6]

In AC dielectric tests there is a one to one proportionality between the test level and the corresponding dielectric stress. For example, during the induced voltage test we feed the transformer with double the rated voltage to induce double the rated dielectric stress between turns in all windings. Moreover the ratio between the stress between turns during the induced voltage test and normal service condition is not influenced by the type of the transformer mineral oil used during the test and in service (because different oils have practically the same permittivity).

This proportionality between voltage and stress and independence from mineral oil type is not generally true for PR (and DC) test because the dielectric stress depends not only on voltage but also on a) polarization time and b) oil conductivity (which can be significantly different depending on the type of mineral oil).

Therefore, to evaluate the effectiveness of the PR test, it is necessary to determine the relation between the safety margin of 1.25 in the voltage test level (as per IEC 61378-2) and the safety margin in dielectric applied in dielectric stress for different polarization times and oil conductivities.

4.1.1. Influence of oil conductivity and polarization time on the effectiveness of the PR test

To investigate the matter further, a case of an oil side insulation system of an resin impregnated paper (RIP) Valve bushing of an HVDC transformer was chosen. The focus was on the creep (surface) stress on the bushing because this location is known to experience critical stresses during PR.

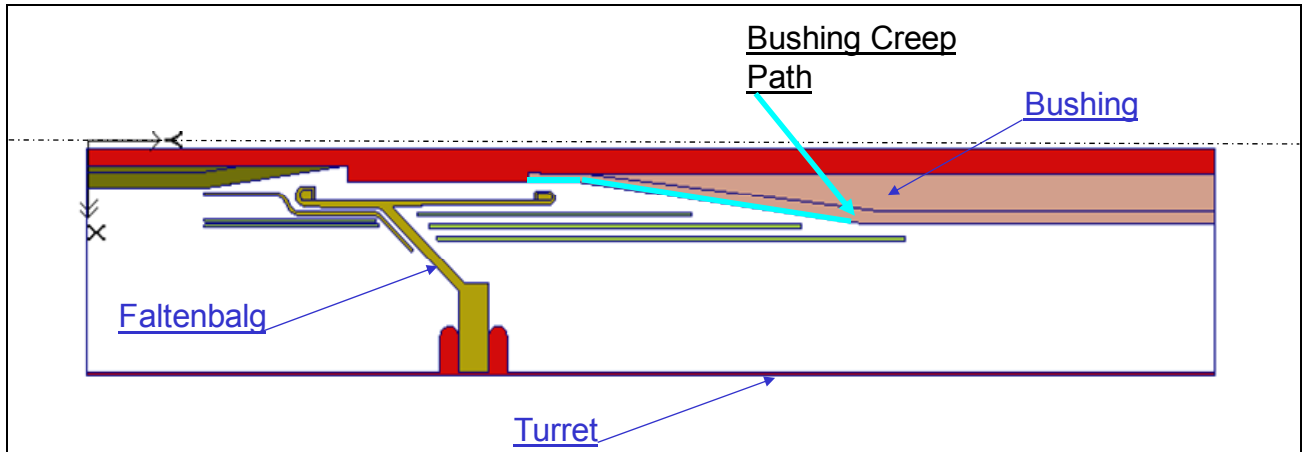

Figure 11. RIP HVDC bushing with its insulation system

This insulation system was studied by means of a transient dielectric field FEM simulation (taking into account materials conductivity, permittivity and time). These simulations took into account different:

- a) polarization times,
- b) oil conductivities,
- c) test levels.

Recent measurements have shown that new mineral oils at 20° C can have electrical conductivities which differ by more than an order of magnitude (while conductivity of oil impregnated high density pressboard remained almost constant). See Figure 12.

Two typical conductivities at 20° C were considered for the studies:

- Oil $\sigma = 10^{-13}$ S/m (value normally assumed for oil)
- Oil $\sigma = 10^{-14}$ S/m (value measured for new types of oil)

While the conductivity of the oil impregnated high density pressboard at 20° C was kept at 10^{-15} S/m

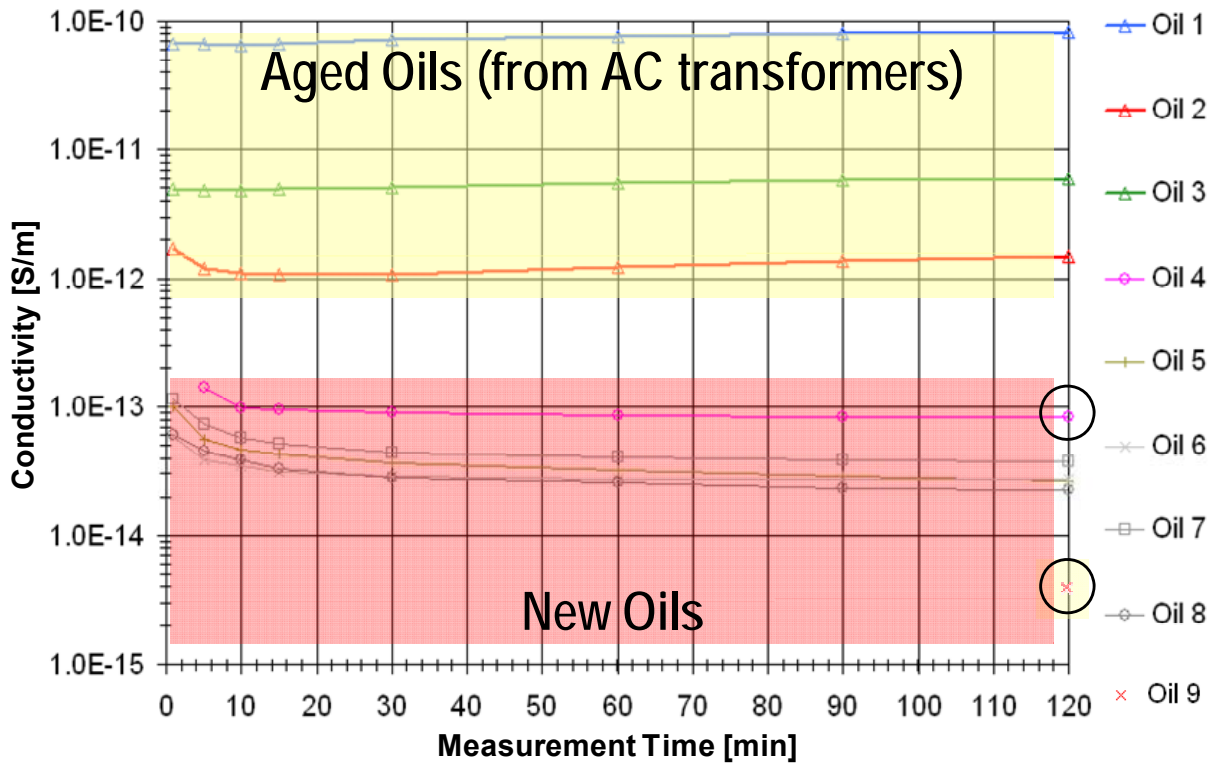

Figure 12. Conductivity of new and aged mineral oils of different type, measured at 20° C, 1 kV/mm

The first set of simulations looked into the effect of increasing polarization time for the two oil conductivities mentioned above. The voltage waveform is that of the PR-test in Figure 13. with $T_{PR} = 90, 180, 360$ and 720 min.

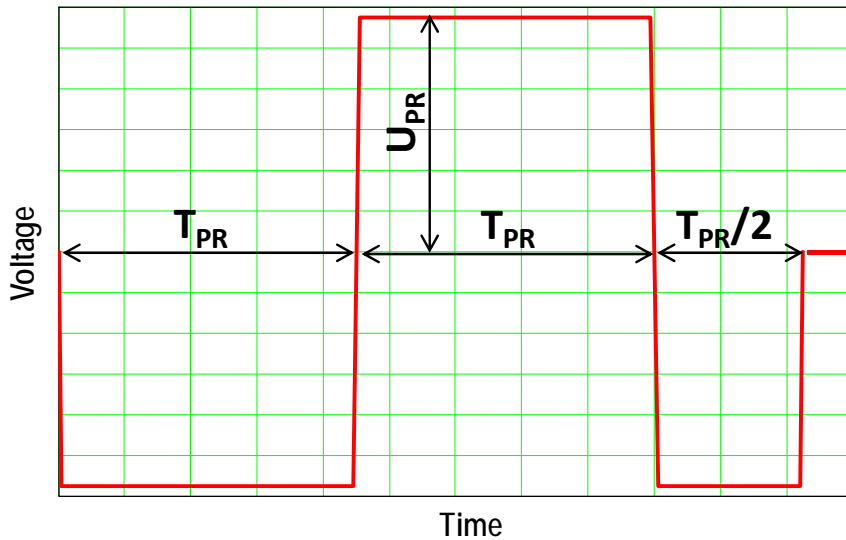

Figure 13. Voltage waveform used for simulations

The simulation results are shown in the Table 4. where 1 pu is the highest dielectric stress taking place in a polarity reversal performed during service (therefore with a voltage 1.25 times lower than the one applied during the test).

Table 4. Simulations Results – Investigation of the effect of different polarization duration for different oils.

		T _{PR} [min]				
		90	180	360	720	∞
Max dielectric stress during test [pu]	σ Oil = 10 ⁻¹³ S/m	1.02	1.13	1.21	1.24	1.25
	σ Oil = 10 ⁻¹⁴ S/m	0.36	0.37	0.38	0.38	0.39

The first observations that can be drawn from these results are that:

- for the polarization time presently used for the PR test (90 min) and Oil $\sigma = 10^{-13}$ S/m, the test voltage, 1.25 times higher than in service, corresponds only to a max dielectric stress only 2% higher than the one in service.
- if an oil with $\sigma = 10^{-14}$ S/m is used during the test and oil with $\sigma = 10^{-13}$ S/m is used in service, then the PR test is useless because the dielectric stress during test would be lower than in service. The test voltage, 1.25 times higher than in service, would correspond to a max dielectric stress equal to only 36% of the stress experienced during service.**

A change in oil conductivity between test and service may have dramatic effects on the polarization time and the stress distribution (amplitude and duration) among the oil and the other insulating materials.

4.1.2 Polarity reversal during DC line faults

When a DC transmission line fault occurs the line voltage goes to zero almost instantaneously (in less than 2ms). The rectifier current increases and the rectifier firing angle goes to 90 degrees in order to control the current. The line protection detects the fault within 30 to 50ms and forces the firing angle of the rectifier to 155 degrees. The increase in firing angle causes the DC line voltage to approximately half the nominal voltage in the reverse polarity and extinguishes the fault. After a preselected deionization time (approx. 250 ms) the rectifier firing angle is forced to normal operation (13-18 degrees) and the DC line voltage returns to the normal polarity. The change in polarity reversal occurs in less than 30 ms. Figure 5 shows a typical waveform for a DC line fault.

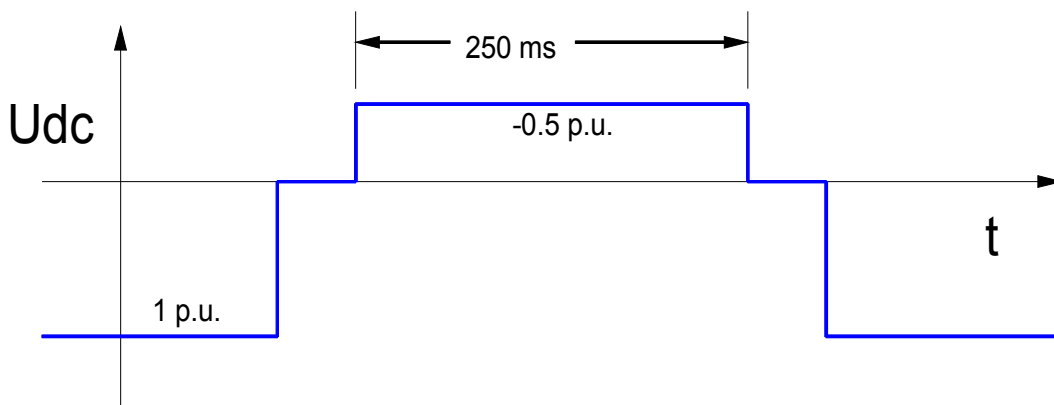

Figure 14. - DC line voltage during a line fault

The polarity reversal during the DC line fault occurs over a very short period compared to the polarity reversal test. Table 5. shows the differences between the polarity reversal test, normal power reversal and the DC line fault.

Table 5. - Difference between the polarity reversal test and operating conditions

	Polarity Reversal Type		
	Power reversal	Standard Test	HVDC Line Fault
Steady State DC reached before reversal	Yes	No	Yes
Time between two reversals	>12 hr	90 min	300 ms
Reversal time	<2 min	<2 min	<2ms
Steady State DC reached after reversal	Yes	No	No

Since the polarity reversal in line fault occurs in less than 2 to 30 ms compared to 120 s in the polarity reversal test, simulations were performed to see the effect of the reversal time. Figures 15 , 16 and 17 show the stresses on the bushing surface after various time intervals.

The time to reverse the polarity:

1. Slightly affected the stress distribution at the time when the reversal was completed.
2. Did not affect the stress distribution (and its peak value) in following instants.

These results are not surprising if we consider that even 120 s (for the test PR) is a short time when compared with the insulation system time constants.

The 2 polarity reversals related to a HVDC line fault take place in less than 250 ms. In such a short time the charge and voltage distribution due to DC polarization cannot change significantly. This transient can be related to the very first instants of a power reversal PR, although less severe because the pole voltage swings to just approx 50% of the full voltage.

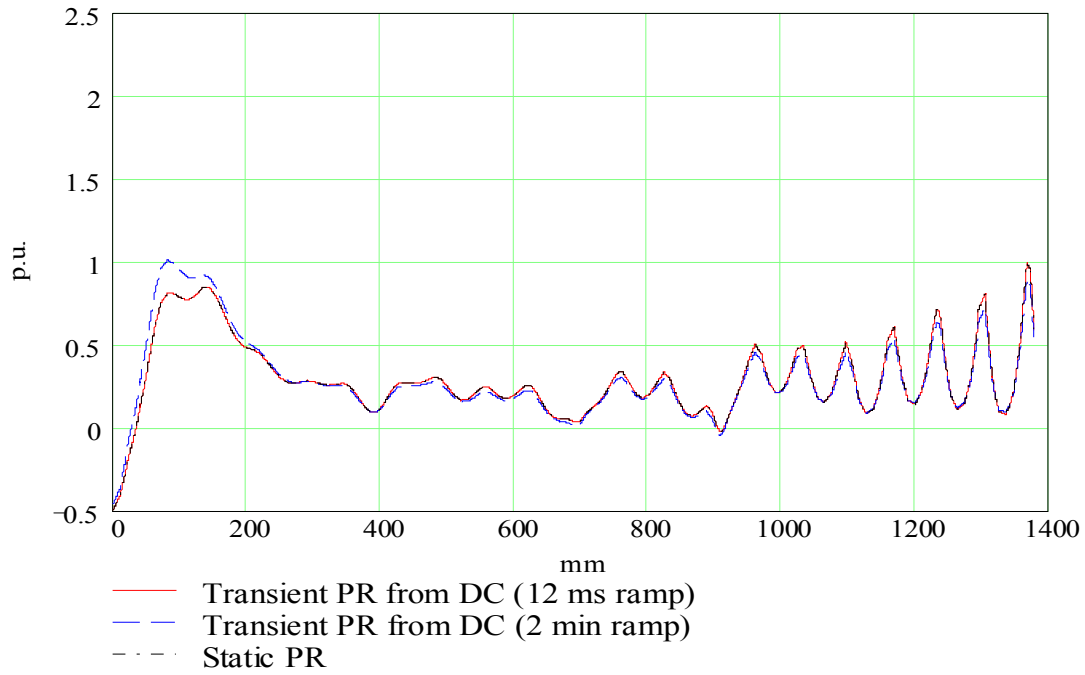

Figure 15. - Creep stress on bushing surface at $t=0$ s after PR completion

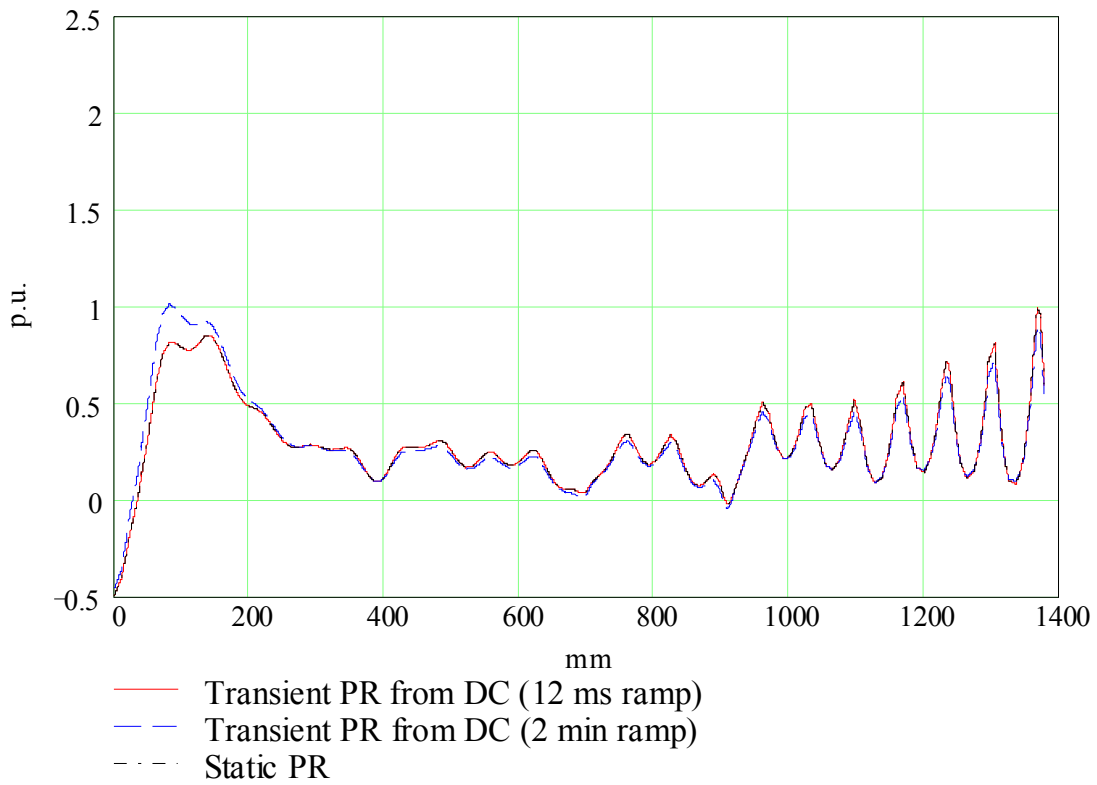

Figure 16. - Creep stress on bushing surface at $t = 300$ s after PR completion

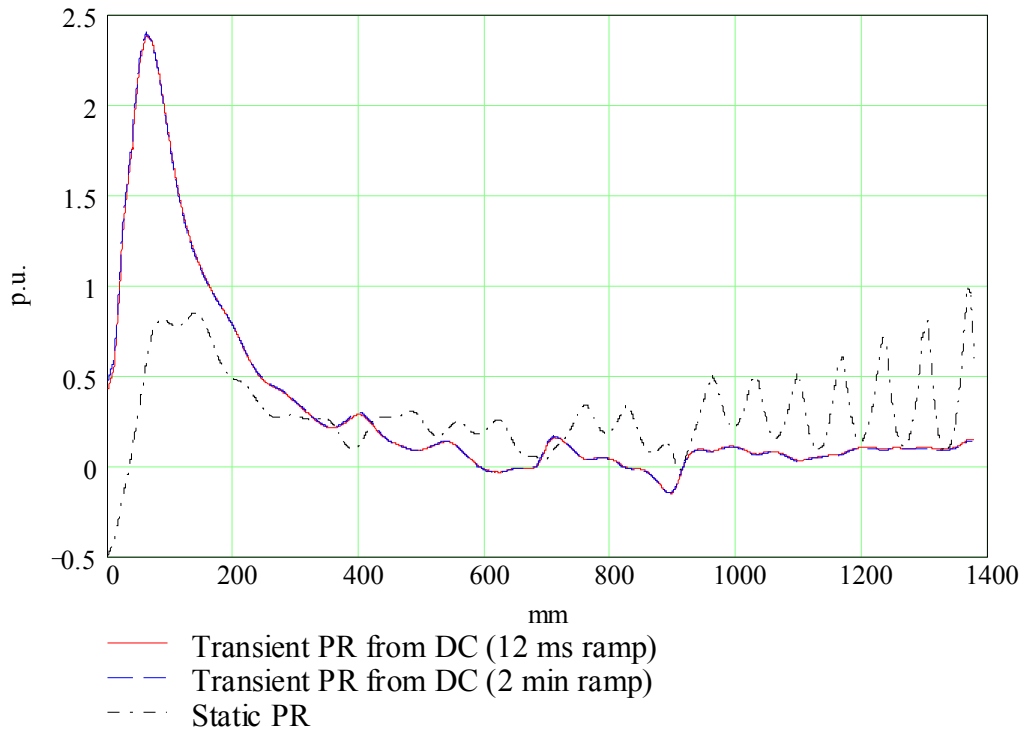

Figure 17. - Creep stress on bushing surface at t - 1200 s after PR completion

4.1.3. Investigation of possible improvements of the PR test

The next step was to determine whether it was possible to improve the PR test taking into account the following goals:

1. Dielectric stress safety margin corresponding to the test voltage safety margin
2. Have equal magnitude dielectric stress profiles for both the first and second reversal during the tests
3. Last polarity applied long enough to reach worst dielectric stress condition

And the following practical industrial constraints:

1. Use of the existing test equipment
2. Duration kept close to the one used in the present test specification.

Taking into account an oil with $\sigma = 10^{-13}$ S/m, the cases illustrated in the Table 5. were investigated. Table 6. Possible PR tests investigated

	Case 0	Case 1	Case 2	Case 3	Case 4
U_{PR}	IEC	IEC	IECx1.5/1.25	IEC	IECx1.5/1.25
T_{PR1} [min]	∞	90	90	120	90
T_{PR2} [min]	120	90	90	120	120
T_{PR3} [min]		45	45	60	60

The summary of the simulation results are shown in the Table 7.

Table 7. Simulation results for the different PR tests investigated

	Case 0	Case 1	Case 2	Case 3	Case 4
U_{PR}	IEC	IEC	IECx1.5/1.25	IEC	IECx1.5/1.25
T_{PR1} [min]	∞	90	90	120	90
T_{PR2} [min]	120	90	90	120	120
T_{PR3} [min]		45	45	60	60
Max $ E_i $ on bushing after 1 st PR [pu]	1.25	1.02	1.23	1.07	1.23
Max $ E_i $ on bushing after 2 nd PR [pu]		0.91	1.09	0.97	1.19
Time of Max $ E_i $ after 1 st PR [min]	50	55	55	55	55
Time of Max $ E_i $ after 2 nd PR [min]		45	45	50	45

It can be observed that:

- the second polarity reversal in the present test (Case 1) is even less effective than the first one
- a new PR test (Case 4) with a 20% higher test level ($U_{pr} = 1,5((N-0,5)U_{dm} + 0,35U_{vm})$) and 45min longer duration (90-120-60 min) would meet both goals and constraints set above.

However, it is very important to highlight that a potential new PR test, as per Case 4, while addressing the present shortcomings due to insufficient polarization time, would not solve the potential problem related to different oil conductivities and could limit the effectiveness of this modified test.

4.1.4. Present knowledge about oil electrical conductivity

HVDC transformer manufacturers and the end users, pay great attention to some properties (particle content for example) of oil used in their HVDC transformers. However from the information gathered by the group, it was found out that:

- oil electrical conductivity is not measured on a regular basis (not even by oil producers),
- there is no test method employed consistently,
- existing standard test methods measure oil conductivity at dielectric stress below 0.5 kV/mm while during a polarity reversal the oil can be subjected to dielectric stresses in the range of 5-10 kV/mm.

Considering that it is very common that the HVDC transformer in service will be filled with oils different from those used during the factory tests, it follows that we have no information about the real effectiveness of the PR tests performed.

4.1.5. Recommendations regarding the PR test

Based on the findings exposed in the previous paragraphs, the group recommendation is to address the oil conductivity issue as the first priority.

This shall be done by:

- a) measuring oil electrical conductivity at different stages of transformer life
- b) studying the effect of oil electrical conductivity variations (as a function of the dielectric stress and temperature) by means of simulations at the design review stage.

There is a need to develop a new test to measure oil electrical conductivity under conditions associated with HVDC operation. However, this task is outside the scope and competences of this JWG. The JWG submitted to CIGRE a detailed term of reference (TOR) for the initiation of a new D1 WG (or D1/A2 JWG) to address this issue.

The experience gathered following the application of the JWG recommendations will be a base for further considerations regarding any future test modifications.

5. CONCLUSION

The JWG has produced a specific design review guide in order to provide a solid platform and effective tool for reviewing specific aspects of HVDC applications and interactions between Converter Transformers and associated systems, both AC and DC alike.

In addition, the JWG has conducted 3 failure surveys and the result show that, after a significant increase in the period from 2003 to 2004, the failure rate was monotonously decreasing through the period 2005-2006 and **finally dropped in 2007-2008 to a level below the rate recorded for the period 1991 to 2002.**

This finding is encouraging, indicating a potential positive effect of the latest version of the IEC 61378-2 standard as well as a strong action in response to an upsurge of the HVDC Converter Transformers failures related to corrosive oil.

The existing standard test specifications were reviewed. Even though the JWG has identified a possible improvement for the existing PR test, it has agreed not to recommend the actual modification of the existing test due to practical and logistic constraints as well as a heavy dependence on the oil quality.

There is a need to develop a new test to measure oil electrical conductivity under conditions associated with HVDC operation. However, this task is outside the scope and competences of this JWG. The JWG submitted to CIGRE a detailed term of reference (TOR) for the initiation of a new D1 WG (or D1/A2 JWG) to address this issue.

The experience gathered following the application of the JWG recommendations will be a base for further considerations regarding any future test modifications.

6. BIBLIOGRAPHY

- 1] CIGRE JTF B4.04/A2-1; “Report – Analysis of HVDC Thyristor Converter Transformer performance – Summary of 1972 – 2002 Failures”, Electra No. 212, February 2004.
- [2] CIGRE JTF B4.04/A2-1; ”Analysis of HVDC Thyristor Converter Transformer performance”, Brochure No. 240. 2004.
- [3] CIGRE WG 12.22, “Guidelines for conducting Design Reviews for transformers 100 MVA and 123 kV and above”, Brochure No. 204, August 2002.
- [4] CIGRE JTF 12/14.10-01; “ In service performance of HVDC Converter Transformers and oil-filled Smoothing Reactors”, Electra, No. 155, August, 1994, pages 6 – 30.
- [5] CIGRE JTF 12/14.10; “The relationship between test and service stresses as a function of the resistivity ratio for HVDC Converter Transformers and Smoothing Reactors”, Electra, No. 157, December 1994, pages 32 – 58.
- [6] IEC 61378-3, Ed. 1.0; Converter Transformers, Part 3- Application Guide, 14/487 CDV, April 2006.

APPENDIX

CIGRE
International Conference of
Large High Voltage Electric Systems
Study Committees A2/B4
Power Transformers/DCLinks

QUESTIONNAIRE ON PERFORMANCE OF THYRISTOR VALVE CONVERTER TRANSFORMERS

For

Joint Working Group JWG A2/B4-28

**HVDC Converter Transformer
Design Review, Test Procedures, Ageing Evaluation and Reliability in Service**

This questionnaire is addressed to Users of HVDC thyristor valve converters for obtaining information and data on converter transformers operating experience. Last survey was performed in 2001 by JTF 14.04/12-1 for which report has been published as technical brochure 240. As per one of the recommendations of JTF 14.04/12-1, JWG A2/B4-28 has been formed to provide recommendations relating to design review, test procedures, ageing evaluation and reliability in service.

Your response will be of considerable value to CIGRE JWG A2/B4-28 in fulfilling its mandate. Your answers are essential to JWG for trying to establish areas within converter transformers that still require additional attention. These areas could imply design, construction, testing, operation and/or maintenance aspects.

The survey addresses all HVDC thyristor valve converter transformers for system rated power as low as 50 MW.

This questionnaire has two parts:

Part 1, -- This part relates to the characteristics of the transformers and the related HVDC system.

Part 2, -- This part report applies only to Transformer Failures that were not reported to the last survey by JTF 14.04/12-1.

**QUESTIONNAIRE ON PERFORMANCE OF THYRISTOR VALVE CONVERTER
TRANSFORMERS
PART 1**

1. Transformer Characteristics

- 1. Voltage Rating
 - i. System side _____
 - ii. Valve winding side _____
- 2. Power rating (Single Unit) _____
- 3. Number of windings (in tank) _____
- 4. Number of phases (in tank) _____
- 5. Year of In-service _____
- 6. Any windings other than those used for converter (in tank) _____
- 7. Function of windings in Q6
 - i. Synchronous condenser _____
 - ii. AC Filters _____
 - iii. Other _____

2. HVDC System Characteristics

- 1. System DC voltage _____
- 2. Power rating _____
- 3. Long distance Yes _____ No _____
- 4. Back to Back Yes _____ No _____
- 5. Number of poles _____
- 6. Number of converters per pole _____
- 7. Type of converters
 - i. 6-Pulse _____
 - ii. 12-pulse _____

**8. QUESTIONNAIRE ON PERFORMANCE OF THYRISTOR VALVE
CONVERTER TRANSFORMERS**

PART 2 (Analysis Information)

Use this form to report all converter transformers not reported in the last survey.

Converter Transformer Type of Failure

For the purpose of this questionnaire, a failure is defined as removal of the unit from service because of major damage to active (energized) parts, or potential failure of active parts following diagnostic such as gas in oil, or non active part requiring transformer to be repaired. If you have experienced converter transformer failure, please answer the following:

1. Indicate which of the transformer component or accessory has failed

1.01 AC winding: _____

1.02 Valve winding: _____

1.03 On load tap changer winding: _____

1.04 Core: _____

1.05 Internal connection between winding and bushing: _____

1.06 On load tap changer diverter/selector switch: _____

1.07 Cooling pump: _____

1.08 Cooling radiator/ or valve leak: _____

1.09 Conservator/ or main tank oil leak: _____

1.10 Oil dielectric failure: _____

1.11 Other: _____

2. Description of transformer failure

Describe in as much details as possible problem experienced with failed transformer or its accessories including if possible which protective devices operated:

2.1 Describe in as much detail as possible corrective measures taken

3. What were operating conditions prior to failure: (Describe)

4. Transformer replacement by spare unit

What has been total time (in hours) for replacement of failed unit by spare transformer from time of failure to time of resuming service to pre-fault power level :

5. Multiple transformer failures

5.01 If more than one unit failure was experienced in a converter station, or for the same generation of transformers in converters of a same system, please provide information requested below:

5.02 How many units failed?

5.02 What period of time(months) between failures?

5.03 Was problem considered as generic?

5.04 Was it possible to have transformer repaired before another unit failed? If not, for how many months was converter off service?

5.05 In the case of a generic failure, were all units in converter removed from service, repaired at site or sent for repair/modified in factory and put back in service?

5.06 What was the average time (hours), from time of stopping converter to time of restart, for replacing existing transformer by newly modified unit?

5.07 How many transformer units needed to be removed from service, modified and put back in service?

5.08 What has been approximate total time (hours) of converter or converter group forced outage?

6. Were factory type and routine tests performed to ensure against such failure?

7. Identify test standards used for factory type and routine tests:

8. Indicate whether unit failed factory test (explain why):

9. Please indicate any other pertinent information relative to the questionnaire:

10. If you have any concern or suggestions for futures studies or investigations by the JTF, please identify below:

11. Any other comment:

HVDC Link Name: _____

Date: _____

By: _____