

NFPA[®]

909

**Code for the Protection of
Cultural Resource Properties —
Museums, Libraries, and
Places of Worship**

2017



IMPORTANT NOTICES AND DISCLAIMERS CONCERNING NFPA® STANDARDS

NOTICE AND DISCLAIMER OF LIABILITY CONCERNING THE USE OF NFPA STANDARDS

NFPA® codes, standards, recommended practices, and guides (“NFPA Standards”), of which the document contained herein is one, are developed through a consensus standards development process approved by the American National Standards Institute. This process brings together volunteers representing varied viewpoints and interests to achieve consensus on fire and other safety issues. While the NFPA administers the process and establishes rules to promote fairness in the development of consensus, it does not independently test, evaluate, or verify the accuracy of any information or the soundness of any judgments contained in NFPA Standards.

The NFPA disclaims liability for any personal injury, property or other damages of any nature whatsoever, whether special, indirect, consequential or compensatory, directly or indirectly resulting from the publication, use of, or reliance on NFPA Standards. The NFPA also makes no guaranty or warranty as to the accuracy or completeness of any information published herein.

In issuing and making NFPA Standards available, the NFPA is not undertaking to render professional or other services for or on behalf of any person or entity. Nor is the NFPA undertaking to perform any duty owed by any person or entity to someone else. Anyone using this document should rely on his or her own independent judgment or, as appropriate, seek the advice of a competent professional in determining the exercise of reasonable care in any given circumstances.

The NFPA has no power, nor does it undertake, to police or enforce compliance with the contents of NFPA Standards. Nor does the NFPA list, certify, test, or inspect products, designs, or installations for compliance with this document. Any certification or other statement of compliance with the requirements of this document shall not be attributable to the NFPA and is solely the responsibility of the certifier or maker of the statement.



ALERT: THIS STANDARD HAS BEEN MODIFIED BY A TIA OR ERRATA

Users of NFPA codes, standards, recommended practices, and guides (“NFPA Standards”) should be aware that NFPA Standards may be amended from time to time through the issuance of Tentative Interim Amendments or corrected by Errata. An official NFPA Standard at any point in time consists of the current edition of the document together with any Tentative Interim Amendment and any Errata then in effect.

In order to determine whether an NFPA Standard has been amended through the issuance of Tentative Interim Amendments or corrected by Errata, visit the “Codes & Standards” section on NFPA’s website. There, the document information pages located at the “List of NFPA Codes & Standards” provide up-to-date, document-specific information including any issued Tentative Interim Amendments and Errata.

To view the document information page for a specific NFPA Standard, go to <http://www.nfpa.org/docinfo> to choose from the list of NFPA Standards or use the search feature to select the NFPA Standard number (e.g., NFPA 101). The document information page includes postings of all existing Tentative Interim Amendments and Errata. It also includes the option to register for an “Alert” feature to receive an automatic email notification when new updates and other information are posted regarding the document.

IMPORTANT NOTICES AND DISCLAIMERS CONCERNING NFPA® STANDARDS

ADDITIONAL NOTICES AND DISCLAIMERS

Updating of NFPA Standards

Users of NFPA codes, standards, recommended practices, and guides (“NFPA Standards”) should be aware that these documents may be superseded at any time by the issuance of new editions or may be amended from time to time through the issuance of Tentative Interim Amendments or corrected by Errata. An official NFPA Standard at any point in time consists of the current edition of the document together with any Tentative Interim Amendments and any Errata then in effect. In order to determine whether a given document is the current edition and whether it has been amended through the issuance of Tentative Interim Amendments or corrected through the issuance of Errata, consult appropriate NFPA publications such as the National Fire Codes® Subscription Service, visit the NFPA website at www.nfpa.org, or contact the NFPA at the address listed below.

Interpretations of NFPA Standards

A statement, written or oral, that is not processed in accordance with Section 6 of the Regulations Governing the Development of NFPA Standards shall not be considered the official position of NFPA or any of its Committees and shall not be considered to be, nor be relied upon as, a Formal Interpretation.

Patents

The NFPA does not take any position with respect to the validity of any patent rights referenced in, related to, or asserted in connection with an NFPA Standard. The users of NFPA Standards bear the sole responsibility for determining the validity of any such patent rights, as well as the risk of infringement of such rights, and the NFPA disclaims liability for the infringement of any patent resulting from the use of or reliance on NFPA Standards.

NFPA adheres to the policy of the American National Standards Institute (ANSI) regarding the inclusion of patents in American National Standards (“the ANSI Patent Policy”), and hereby gives the following notice pursuant to that policy:

NOTICE: The user’s attention is called to the possibility that compliance with an NFPA Standard may require use of an invention covered by patent rights. NFPA takes no position as to the validity of any such patent rights or as to whether such patent rights constitute or include essential patent claims under the ANSI Patent Policy. If, in connection with the ANSI Patent Policy, a patent holder has filed a statement of willingness to grant licenses under these rights on reasonable and nondiscriminatory terms and conditions to applicants desiring to obtain such a license, copies of such filed statements can be obtained, on request, from NFPA. For further information, contact the NFPA at the address listed below.

Law and Regulations

Users of NFPA Standards should consult applicable federal, state, and local laws and regulations. NFPA does not, by the publication of its codes, standards, recommended practices, and guides, intend to urge action that is not in compliance with applicable laws, and these documents may not be construed as doing so.

Copyrights

NFPA Standards are copyrighted. They are made available for a wide variety of both public and private uses. These include both use, by reference, in laws and regulations, and use in private self-regulation, standardization, and the promotion of safe practices and methods. By making these documents available for use and adoption by public authorities and private users, the NFPA does not waive any rights in copyright to these documents.

Use of NFPA Standards for regulatory purposes should be accomplished through adoption by reference. The term “adoption by reference” means the citing of title, edition, and publishing information only. Any deletions, additions, and changes desired by the adopting authority should be noted separately in the adopting instrument. In order to assist NFPA in following the uses made of its documents, adopting authorities are requested to notify the NFPA (Attention: Secretary, Standards Council) in writing of such use. For technical assistance and questions concerning adoption of NFPA Standards, contact NFPA at the address below.

For Further Information

All questions or other communications relating to NFPA Standards and all requests for information on NFPA procedures governing its codes and standards development process, including information on the procedures for requesting Formal Interpretations, for proposing Tentative Interim Amendments, and for proposing revisions to NFPA standards during regular revision cycles, should be sent to NFPA headquarters, addressed to the attention of the Secretary, Standards Council, NFPA, 1 Batterymarch Park, P.O. Box 9101, Quincy, MA 02269-9101; email: stds_admin@nfpa.org

For more information about NFPA, visit the NFPA website at www.nfpa.org. All NFPA codes and standards can be viewed at no cost at www.nfpa.org/docinfo.

Copyright © 2016 National Fire Protection Association®. All Rights Reserved.

NFPA® 909

Code for the

Protection of Cultural Resource Properties — Museums, Libraries, and Places of Worship

2017 Edition

This edition of NFPA 909, *Code for the Protection of Cultural Resource Properties — Museums, Libraries, and Places of Worship*, was prepared by the Technical Committee on Cultural Resources. It was issued by the Standards Council on November 11, 2016, with an effective date of December 1, 2016, and supersedes all previous editions.

This document has been amended by one or more Tentative Interim Amendments (TIAs) and/or Errata. See “Codes & Standards” at www.nfpa.org for more information.

This edition of NFPA 909 was approved as an American National Standard on December 1, 2016.

Origin and Development of NFPA 909

Since the first NFPA document was issued on this subject in 1948 (*Protecting Our Heritage*), the Technical Committee on Cultural Resources has developed a series of recommended practices to govern these specialized buildings and sites. Five separate documents governing libraries, museums, places of worship, historic structures, and historic sites existed in 1996.

In each case, the documents were written as recommended practices or guides. There were a number of reasons why the documents were developed and maintained as such. One reason had to do with the delicate nature of the facilities and sites. Unlike commercial buildings, “new” historic structures are not constructed. In other words, all the historic structures are existing, making retrofit of many common fire protection systems impractical to install in some cases. In addition, retrofit of fire alarm systems or sprinkler systems can be cost prohibitive for a smaller, historically significant structure. Unfortunately, many of the readily available solutions to correct fire protection problems in other types of existing facilities might not be practical in the case of older, historic buildings.

A number of philosophical issues centered on the methods used to protect cultural resource facilities. One main item dealt with a structured fire prevention program that is carried out by the facility operator. The span of these protection schemes must account for structures ranging from single-family dwellings to public libraries to public museums.

In 1997, work on a comprehensive project to merge the five separate documents was completed. A new standard, NFPA 909, *Standard for the Protection of Cultural Resources, Including Museums, Libraries, Places of Worship, and Historic Properties*, consolidated the fire protection requirements for libraries, museums, and places of worship into one document. This milestone recognized that many traditional fire protection solutions do not work unless significant resources are applied to a given problem or situation. This same philosophy was carried over to the 2001 edition of NFPA 909. A continued focus of the 2001 edition was the need to have a structured fire prevention program that would be carried out by the facility operator.

The status of the 2001 edition was upgraded to a code, rather than a standard, in recognition of the wide range of requirements that exist in NFPA 909. Specifically, sections of NFPA 909 stipulate when and where certain requirements are mandatory. In addition to those changes, the chapter on historic structures and buildings was completely revised. That chapter defers to NFPA 914, *Code for Fire Protection of Historic Structures*.

The 2005 edition of NFPA 909 underwent a major reorganization in accordance with the *Manual of Style for NFPA Technical Committee Documents*. Technical changes included the deletion of a previous annex on fire risk assessment in heritage premises in favor of reference to more current approaches to the subject. Other changes included the type of automatic sprinklers to be used in cultural

resource properties and the activation of fire dampers. In addition, emergency action checklists and inspection forms were added for places of worship.

The 2010 edition of NFPA 909 was a complete revision that reflected the addition of security to the committee's scope. Technical changes included the addition of "hazards other than fire" to the goals and objectives; required a vulnerability assessment; added new chapters on planning for protection, emergency operations, and security; and included a new annex describing commonly used premises protection systems and equipment.

Building on the myriad changes made for the 2010 edition, the committee added new provisions to the 2013 edition and clarified many requirements. The application and use of certain materials such as noncombustible and limited-combustible materials were revised to note how they are to be used rather than simply defining them. A number of changes were accepted that centered on the operational features of the facility — a critical component in these occupancies. The changes included determining the loss thresholds that a property can tolerate, maintaining a line of communication with the authority having jurisdiction, and clarifying the list of elements that the vulnerability assessment needs to consider. An expanded set of requirements was added to assist the governing body in executing supplemental inspections of automatic sprinkler systems with regard to concerns over interior corrosion.

Updates for the 2017 edition include expanded provisions for outdoor collections and archaeological sites and their protection against wildfire; further clarification of sprinkler system corrosion protection criteria; mandated integrated system testing per NFPA 4, *Standard for Integrated Fire Protection and Life Safety System Testing*; and the addition of numerous events to Annex B, Fire Experience in Cultural Properties.

Technical Committee on Cultural Resources

Donald C. Moeller, *Chair*

The Fire Consultants, Inc., CA [E]
Rep. California State Historical Building Safety Board

Michael Coull, *Secretary*

Heritage Fire and Safety Ltd., Scotland, United Kingdom [SE]
Rep. Historic Scotland

Clare Ray Allshouse, City of Shoreline, Washington, WA [E]

Nicholas Artim, Fire-Safety Network, VT [SE]

Eileen E. Brady, Washington State University, WA [U]

Bradford T. Cronin, Newport Fire Department, RI [E]
Rep. Rhode Island Association of Fire Marshals

Grant Crosby, U.S. Department of the Interior, AK [E]

Laura E. Doyle, U.S. General Services Administration, DC [U]

Daniel P. Finnegan, Siemens Industry, Inc., IL [M]
Rep. National Electrical Manufacturers Association

Robert F. Fisher, FM Global, OH [I]

Russell P. Fleming, National Fire Sprinkler Association, Inc., NY [M]

Deborah L. Freeland, Arthur J. Gallagher & Company, CA [I]

Daniel J. Hubert, Amerex/Janus Fire Systems, IN [M]
Rep. Fire Suppression Systems Association

Michael Kilby, Smithsonian Institution, DC [U]

A. M. Fred Leber, LRI Fire Protection Engineering, Inc., ON [SE]

Nancy Lev-Alexander, U.S. Library of Congress, DC [U]

Helen R. Lowery, DuPont Fire Extinguishants, OK [M]
Rep. Halon Alternatives Research Corporation

Wayne D. Moore, JENSEN HUGHES, RI [SE]

Kevin D. Morin, Code Consultants, Inc., NY [SE]

Luca Nassi, Italian National Fire Department, Italy [E]

Daniel E. Nichols, State of New York Department of State, NY [E]

Thomas F. Norton, Norel Service Company, Inc., MA [M]
Rep. Automatic Fire Alarm Association, Inc.

Sheila Palmer, Chubb Group of Insurance Companies, NY [I]

Chris Portway, Pepperdine University, CA [U]

Milosh T. Puchovsky, Worcester Polytechnic Institute, MA [SE]

Colin M. Robertson, Ecclesiastical Insurance, Canada [I]

Patricia A. Silence, Colonial Williamsburg Foundation, VA [U]

John M. Watts, Jr., Fire Safety Institute, VT [SE]

Robert D. Wilson, National Gallery of Art, DC [U]

Alternates

James H. Antell, JENSEN HUGHES, Malaysia [SE]
(Alt. to Wayne D. Moore)

Ronald P. Bertone, Robson Forensic, FL [SE]
(Alt. to A. M. Fred Leber)

Shane M. Clary, Bay Alarm Company, CA [M]
(Alt. to Thomas F. Norton)

Bradford Colton, American Pacific Corporation, NV [M]
(Alt. to Helen R. Lowery)

Joseph Dafin, U.S. General Services Administration, DC [U]
(Alt. to Laura E. Doyle)

Scott T. Franson, The Viking Corporation, MI [M]
(Alt. to Russell P. Fleming)

John C. Harrington, FM Global, MA [I]
(Alt. to Robert F. Fisher)

Marilyn E. Kaplan, Preservation Architecture, NY [SE]
(Alt. to John M. Watts, Jr.)

Thomas A. Nappo, Chubb Group of Insurance Companies, MO [I]
(Alt. to Sheila Palmer)

Todd J. Neitzel, U.S. Department of the Interior, CO [E]
(Alt. to Grant Crosby)

Joseph Plati, Code Consultants, Inc., NY [SE]
(Alt. to Kevin D. Morin)

Rodger Reiswig, Tyco/SimplexGrinnell, FL [M]
(Alt. to Daniel P. Finnegan)

Steven Rocklin, T.Y. Lin International, NY [SE]
(Alt. to Nicholas Artim)

Nonvoting

Stewart Kidd, Loss Prevention Consultancy, Ltd., United Kingdom [SE]

Russell B. Leavitt, Telgian Corporation, AZ [SE]
Rep. TC on Sprinkler System Discharge Criteria

Stefano Marsella, National Fire Corps, Italy [SE]

Stephen E. Bush, Winchester, VA [SE]
(Member Emeritus)

Gregory E. Harrington, NFPA Staff Liaison

William Jackson, Lanark, Scotland [SE]
(Member Emeritus)

Danny L. McDaniel, Colonial Williamsburg Foundation, VA [U]
(Member Emeritus)

This list represents the membership at the time the Committee was balloted on the final text of this edition. Since that time, changes in the membership may have occurred. A key to classifications is found at the back of the document.

NOTE: Membership on a committee shall not in and of itself constitute an endorsement of the Association or any document developed by the committee on which the member serves.

Committee Scope: This Committee shall have primary responsibility for documents on fire safety and security for libraries, museums, places of worship, and historic structures and their contents, but shall not overlap the provisions of NFPA 101, *Life Safety Code*, and NFPA 731, *Standard for the Installation of Electronic Premises Security Systems*.

Contents

Chapter 1 Administration	909– 7	Chapter 9 New Construction, Addition, Alteration, Renovation, and Modification Projects	909– 22
1.1 Scope.	909– 7	9.1 General.	909– 22
1.2 Purpose.	909– 7	9.2 Application of Code.	909– 22
1.3 Application.	909– 7	9.3 Project Team.	909– 22
1.4 Equivalency.	909– 8	9.4 Survey.	909– 22
1.5 Compliance Options.	909– 8	9.5 Operations.	909– 22
1.6 Enforcement.	909– 8	9.6 Prioritization of Significant Elements, Collections, and Operations.	909– 22
Chapter 2 Referenced Publications	909– 8	9.7 Potential Threat Identification and Evaluation.	909– 22
2.1 General.	909– 8	9.8 Vulnerability Assessment and Evaluation.	909– 22
2.2 NFPA Publications.	909– 8	9.9 Plans and Designs.	909– 24
2.3 Other Publications.	909– 9	9.10 Options.	909– 24
2.4 References for Extracts in Mandatory Sections.	909– 9	9.11 Design Review.	909– 24
Chapter 3 Definitions	909– 9	9.12 Prescriptive-Based Option.	909– 24
3.1 General.	909– 9	9.13 Performance-Based Option.	909– 29
3.2 NFPA Official Definitions.	909– 9	9.14 Precautions During New Construction, Addition, Alteration, Renovation, and Modification Projects.	909– 33
3.3 General Definitions.	909– 10	Chapter 10 Management Operational Systems	909– 37
Chapter 4 Goals and Objectives	909– 13	10.1 General.	909– 37
4.1 General.	909– 13	10.2 Responsibility/Authority.	909– 37
4.2 Goals.	909– 13	10.3 Reporting Incidents.	909– 37
4.3 Objectives.	909– 13	10.4 Operational Requirements.	909– 37
Chapter 5 Protection Plan	909– 13	10.5 Emergency Response.	909– 37
5.1 General.	909– 13	10.6 Training.	909– 37
5.2 Responsibilities of Governing Body.	909– 13	10.7 Documentation.	909– 38
5.3 Planning Process.	909– 14	10.8 Compliance Audit.	909– 38
5.4 Protection Plan Components.	909– 14	10.9 Enforcement.	909– 38
5.5 Protection Plan Evaluation.	909– 14	10.10 Modification of the Plan.	909– 38
Chapter 6 Protection Plan — Emergency Operations	909– 17	Chapter 11 Fire Prevention	909– 38
6.1 Developing Emergency Operations Procedures.	909– 17	11.1 General.	909– 38
6.2 Contents.	909– 17	11.2 Decorations.	909– 38
6.3 Identification of Emergency Response Personnel.	909– 17	11.3 Fire Spread Control.	909– 38
6.4 Continuity of Essential Building Systems.	909– 17	11.4 Housekeeping.	909– 38
6.5 Occupant Management.	909– 17	11.5 Smoking.	909– 39
6.6 Emergency Response Activities.	909– 17	11.6 Hot Work.	909– 39
6.7 Developing Procedures for Removal or Relocation of Collections.	909– 17	11.7 Open Flames.	909– 39
6.8 Damage Limitation.	909– 17	11.8 Electrical Hazards.	909– 39
6.9 Security.	909– 19	11.9 Penetrations.	909– 39
6.10 Public Affairs.	909– 19	11.10 Structural Fire Protection.	909– 39
6.11 Operational Recovery.	909– 19	11.11 Lightning Protection.	909– 39
6.12 Staff Training.	909– 19	11.12 Protection from Wildland Fires.	909– 40
6.13 Emergency Operations.	909– 19	11.13 Water Control.	909– 40
Chapter 7 Protection Plan — Fire Safety Management	909– 20	Chapter 12 Inspection, Testing, and Maintenance of Protection Systems	909– 40
7.1 Vulnerability Assessment.	909– 20	12.1 General.	909– 40
7.2 Fire Safety Management.	909– 20	12.2 Fire Protection Systems.	909– 40
7.3 Fire Safety Manager.	909– 20	12.3 Electronic Premises Security Systems.	909– 40
7.4 Documentation.	909– 20	12.4 Impairments to Fire Protection Systems.	909– 41
7.5 Training.	909– 21	12.5 Impairments to Electronic Premises Security Systems.	909– 41
Chapter 8 Protection Plan — Security	909– 21	12.6 Heating, Air-Conditioning, and Cooking Equipment.	909– 41
8.1 Vulnerability Assessment.	909– 21	12.7 Chimneys.	909– 42
8.2 Security Component of Protection Plan.	909– 21	12.8 Electrical Systems.	909– 42
8.3 Security Program.	909– 21	12.9 Fire Barriers.	909– 42
8.4 Construction Areas.	909– 22	12.10 Fire Retardant-Treated Materials.	909– 42
8.5 Vacant Areas.	909– 22	12.11 Fire Extinguishers.	909– 42
		Chapter 13 Special Events	909– 42
		13.1 General.	909– 42
		13.2 Occupant Loading.	909– 42

13.3	Means of Egress	909– 42	Annex C	Basics of Fire and Fire Protection Systems	909– 107
13.4	Cooking Equipment	909– 42			
13.5	Smoking	909– 42	Annex D	Security Systems	909– 113
13.6	Fireworks	909– 42			
13.7	Combustibles	909– 42	Annex E	Resources for Protection of Cultural Resource Property Projects	909– 131
13.8	Electrical Equipment	909– 42			
13.9	Access Control	909– 42			
Chapter 14	Museums, Libraries, and Their Collections	909– 42	Annex F	Sample Ordinance Adopting NFPA 909 ...	909– 131
14.1	General	909– 42	Annex G	Compact Storage Fire Tests	909– 132
14.2	Fire Prevention	909– 43	Annex H	Compact Storage Test Program	909– 159
14.3	Security	909– 43	Annex I	Cultural Resource Property Protection Self-Inspection Checklist	909– 163
14.4	Collection Storage Rooms	909– 43			
Chapter 15	Places of Worship	909– 44	Annex J	Fire System Maintenance Checklists	909– 167
15.1	General	909– 44	Annex K	Salvage of Water-Damaged Library Materials	909– 171
15.2	Responsibility	909– 44			
15.3	Protection Plan	909– 44	Annex L	Factory Mutual Engineering Division Laboratory Report	909– 173
15.4	Occupant Loading	909– 45			
15.5	Training	909– 45	Annex M	Measuring the Impact of Fire Extinguisher Agents on Cultural Resource Materials	909– 180
15.6	Fire Prevention	909– 45			
15.7	Fire Protection Systems	909– 45			
15.8	Candles and Censers	909– 45	Annex N	Informational References	909– 181
15.9	Historical Records and Artifacts	909– 45			
15.10	Special Facilities	909– 45			
Annex A	Explanatory Material	909– 46	Index	909– 186
Annex B	Fire Experience in Cultural Properties	909– 90			

NFPA 909

Code for the

Protection of Cultural Resource Properties —
Museums, Libraries, and Places of Worship

2017 Edition

IMPORTANT NOTE: This NFPA document is made available for use subject to important notices and legal disclaimers. These notices and disclaimers appear in all publications containing this document and may be found under the heading “Important Notices and Disclaimers Concerning NFPA Standards.” They can also be viewed at www.nfpa.org/disclaimers or obtained on request from NFPA.

UPDATES, ALERTS, AND FUTURE EDITIONS: New editions of NFPA codes, standards, recommended practices, and guides (i.e., NFPA Standards) are released on scheduled revision cycles. This edition may be superseded by a later one, or it may be amended outside of its scheduled revision cycle through the issuance of Tentative Interim Amendments (TIAs). An official NFPA Standard at any point in time consists of the current edition of the document, together with all TIAs and Errata in effect. To verify that this document is the current edition or to determine if it has been amended by TIAs or Errata, please consult the National Fire Codes® Subscription Service or the “List of NFPA Codes & Standards” at www.nfpa.org/docinfo. In addition to TIAs and Errata, the document information pages also include the option to sign up for alerts for individual documents and to be involved in the development of the next edition.

NOTICE: An asterisk (*) following the number or letter designating a paragraph indicates that explanatory material on the paragraph can be found in Annex A.

A reference in brackets [] following a section or paragraph indicates material that has been extracted from another NFPA document. As an aid to the user, the complete title and edition of the source documents for extracts in mandatory sections of the document are given in Chapter 2 and those for extracts in informational sections are given in Annex N. Extracted text may be edited for consistency and style and may include the revision of internal paragraph references and other references as appropriate. Requests for interpretations or revisions of extracted text shall be sent to the technical committee responsible for the source document.

Information on referenced publications can be found in Chapter 2 and Annex N.

Chapter 1 Administration

1.1 Scope.

1.1.1 This code describes principles and practices of protection for cultural resource properties (including, but not limited to, museums, libraries, and places of worship), their contents, and collections, against conditions or physical situations with the potential to cause damage or loss.

1.1.2 This code covers ongoing operations and rehabilitation and acknowledges the need to preserve culturally significant and character-defining building features and sensitive, often irreplaceable, collections and to provide continuity of operations.

1.1.3* Principles and practices for life safety in cultural resource properties are outside the scope of this code. Where

this code includes provisions for maintaining means of egress and controlling occupant load, it is to facilitate the evacuation of items of cultural significance, allow access for damage limitation teams in an emergency, and prevent damage to collections through overcrowding or as an unintended consequence of an emergency evacuation.

1.1.4 Library and museum collections that are privately owned and not open to the public shall not be required to meet the requirements of this code.

1.2* Purpose. The purpose of this code shall be to prescribe a comprehensive program, consistent with the mission of the organization, that protects cultural resource properties and their contents and collections from conditions or physical situations having the potential to cause damage or loss.

1.3* Application. This code shall apply to culturally significant structures, spaces within other buildings used for culturally significant purposes, and their contents.

1.3.1 New Cultural Resource Property Occupancies. The requirements of this code shall apply to the following:

- (1) New buildings or portions thereof occupied as a cultural resource property
- (2) Additions made to a cultural resource property
- (3) Existing buildings or portions thereof upon change of occupancy to a cultural resource property

1.3.2 Existing Cultural Resource Property Occupancies.

1.3.2.1 An existing building in which a cultural resource property occupancy is housed that was established prior to the effective date of this code shall be permitted to be approved for continued use if it conforms to or is made to conform to provisions of this code to the extent that, in the opinion of the authority having jurisdiction, reasonable protection is provided and maintained.

1.3.2.2 The requirements of this code shall apply when any of the following occur:

- (1)* Changes in the construction classification, occupancy of a space, or the way a space is used
- (2) Alterations, renovations, or modifications that affect the performance of existing fire protection features and systems, including fixed fire protection, detection and suppression, compartmentation, electronic premises security systems, and physical security devices
- (3) Changes that add new sources of ignition or change the nature of the fire load
- (4)* Modifications to operations that increase the vulnerability to deliberate acts by third parties, staff, or visitors; natural disasters; or other reasonably foreseeable hazards
- (5) Changes in the contents that affect the performance of existing fire protection features and systems, including fixed fire protection, detection and suppression, compartmentation, electronic premises security systems, physical security devices, or features intended to mitigate the effects of other conditions or physical situations with the potential to cause damage or loss

1.3.2.3 Libraries, museums, and places of worship housed in historic structures shall also comply with the requirements of NFPA 914.

1.4 Equivalency.

1.4.1* Nothing in this code is intended to prevent the use of systems, methods, or devices of equivalent or superior quality, strength, fire resistance, or effectiveness, provided that the following conditions are met:

- (1) Technical documentation is submitted to the authority having jurisdiction to demonstrate equivalency or superiority.
- (2) The system, method, or device is acceptable to the authority having jurisdiction.

1.4.2 Cultural resource properties or portions of such structures that do not strictly comply with this code shall be considered to be in compliance if it is shown that equivalent protection is provided or that in the opinion of the authority having jurisdiction no unacceptable risk is created or continued through noncompliance.

1.4.3 A designer capable of applying more complete and rigorous analysis to evaluate and address special or unusual problems shall have latitude in the development of the applicable design.

1.4.3.1 In such cases, the designer shall be responsible for demonstrating the validity of the approach.

1.4.3.2 This code shall not eliminate the need for competent engineering judgment.

1.4.3.3 This code shall not be intended to be used as a design handbook.

1.5 Compliance Options.

1.5.1 General. Building design, protection features, and protection programs meeting the collection preservation, building preservation, and continuity of operations goals and objectives of Chapter 4 shall comply with the provisions of 1.5.2, 1.5.3, or both.

1.5.2 Prescriptive-Based Options. A prescriptive-based design shall be in accordance with Chapters 1 through 8, Sections 9.1 through 9.12, Section 9.14, and Chapters 10 through 15 of this code.

1.5.3 Performance-Based Options. A performance-based design shall be in accordance with Chapters 1 through 8, Sections 9.1 through 9.11, Section 9.13, and Chapters 10 through 15 of this code.

1.5.4 Management Operational Systems. Management operational systems that comply with Chapter 10 of this code shall be permitted as an element of a prescriptive-based or performance-based solution.

1.6* Enforcement. This code shall be administered and enforced by the authority having jurisdiction designated by the governing authority. (See Annex F for sample wording for enabling legislation.)

Chapter 2 Referenced Publications

2.1 General. The documents or portions thereof listed in this chapter are referenced within this code and shall be considered part of the requirements of this document.

2.2 NFPA Publications. National Fire Protection Association, 1 Batterymarch Park, Quincy, MA, 02169-7471.

NFPA 1, *Fire Code*, 2015 edition.

NFPA 4, *Standard for Integrated Fire Protection and Life Safety System Testing*, 2015 edition.

NFPA 10, *Standard for Portable Fire Extinguishers*, 2013 edition.

NFPA 11, *Standard for Low-, Medium-, and High-Expansion Foam*, 2016 edition.

NFPA 12, *Standard on Carbon Dioxide Extinguishing Systems*, 2015 edition.

NFPA 12A, *Standard on Halon 1301 Fire Extinguishing Systems*, 2015 edition.

NFPA 13, *Standard for the Installation of Sprinkler Systems*, 2016 edition.

NFPA 14, *Standard for the Installation of Standpipe and Hose Systems*, 2016 edition.

NFPA 15, *Standard for Water Spray Fixed Systems for Fire Protection*, 2017 edition.

NFPA 16, *Standard for the Installation of Foam-Water Sprinkler and Foam-Water Spray Systems*, 2015 edition.

NFPA 17, *Standard for Dry Chemical Extinguishing Systems*, 2017 edition.

NFPA 17A, *Standard for Wet Chemical Extinguishing Systems*, 2017 edition.

NFPA 25, *Standard for the Inspection, Testing, and Maintenance of Water-Based Fire Protection Systems*, 2017 edition.

NFPA 30, *Flammable and Combustible Liquids Code*, 2015 edition.

NFPA 31, *Standard for the Installation of Oil-Burning Equipment*, 2016 edition.

NFPA 33, *Standard for Spray Application Using Flammable or Combustible Materials*, 2016 edition.

NFPA 40, *Standard for the Storage and Handling of Cellulose Nitrate Film*, 2016 edition.

NFPA 42, *Code for the Storage of Pyroxylin Plastic*, 2002 edition.

NFPA 45, *Standard on Fire Protection for Laboratories Using Chemicals*, 2015 edition.

NFPA 51B, *Standard for Fire Prevention During Welding, Cutting, and Other Hot Work*, 2014 edition.

NFPA 54, *National Fuel Gas Code*, 2015 edition.

NFPA 70®, *National Electrical Code®*, 2017 edition.

NFPA 72®, *National Fire Alarm and Signaling Code*, 2016 edition.

NFPA 75, *Standard for the Fire Protection of Information Technology Equipment*, 2017 edition.

NFPA 90A, *Standard for the Installation of Air-Conditioning and Ventilating Systems*, 2015 edition.

NFPA 90B, *Standard for the Installation of Warm Air Heating and Air-Conditioning Systems*, 2015 edition.

NFPA 96, *Standard for Ventilation Control and Fire Protection of Commercial Cooking Operations*, 2017 edition.

NFPA 101®, *Life Safety Code®*, 2015 edition.

NFPA 110, *Standard for Emergency and Standby Power Systems*, 2016 edition.

NFPA 211, *Standard for Chimneys, Fireplaces, Vents, and Solid Fuel-Burning Appliances*, 2016 edition.

NFPA 232, *Standard for the Protection of Records*, 2017 edition.

NFPA 241, *Standard for Safeguarding Construction, Alteration, and Demolition Operations*, 2013 edition.

NFPA 259, *Standard Test Method for Potential Heat of Building Materials*, 2013 edition.

NFPA 265, *Standard Methods of Fire Tests for Evaluating Room Fire Growth Contribution of Textile or Expanded Vinyl Wall Coverings on Full Height Panels and Walls*, 2015 edition.

NFPA 286, *Standard Methods of Fire Tests for Evaluating Contribution of Wall and Ceiling Interior Finish to Room Fire Growth*, 2015 edition.

NFPA 505, *Fire Safety Standard for Powered Industrial Trucks Including Type Designations, Areas of Use, Conversions, Maintenance, and Operations*, 2013 edition.

NFPA 701, *Standard Methods of Fire Tests for Flame Propagation of Textiles and Films*, 2015 edition.

NFPA 703, *Standard for Fire Retardant-Treated Wood and Fire-Retardant Coatings for Building Materials*, 2015 edition.

NFPA 731, *Standard for the Installation of Electronic Premises Security Systems*, 2017 edition.

NFPA 750, *Standard on Water Mist Fire Protection Systems*, 2015 edition.

NFPA 780, *Standard for the Installation of Lightning Protection Systems*, 2017 edition.

NFPA 914, *Code for Fire Protection of Historic Structures*, 2015 edition.

NFPA 1123, *Code for Fireworks Display*, 2014 edition.

NFPA 1144, *Standard for Reducing Structure Ignition Hazards from Wildland Fire*, 2013 edition.

NFPA 2001, *Standard on Clean Agent Fire Extinguishing Systems*, 2015 edition.

NFPA 2010, *Standard for Fixed Aerosol Fire-Extinguishing Systems*, 2015 edition.

2.3 Other Publications.

2.3.1 ASTM Publications. ASTM International, 100 Barr Harbor Drive, P.O. Box C700, West Conshohocken, PA 19428-2959.

ASTM E84, *Standard Test Method for Surface Burning Characteristics of Building Materials*, 2015b.

ASTM E119, *Standard Tests Methods for Fire Tests of Building Construction and Materials*, 2015.

ASTM E136, *Standard Test Method for Behavior of Materials in a Vertical Tube Furnace at 750°C*, 2016.

ASTM E1591, *Standard Guide for Obtaining Data for Fire Growth Models*, 2013.

ASTM E2652, *Standard Test Method for Behavior of Materials in a Tube Furnace with a Cone-shaped Airflow Stabilizer, at 750°C*, 2016.

2.3.2 UL Publications. Underwriters Laboratories Inc., 333 Pfingsten Road, Northbrook, IL 60062-2096.

ANSI/UL 263, *Standard for Fire Tests of Building Construction and Materials*, 2011, revised 2015.

ANSI/UL 723, *Standard for Test for Surface Burning Characteristics of Building Materials*, 2008, revised 2013.

2.3.3 Other Publications.

Merriam-Webster's Collegiate Dictionary, 11th edition, Merriam-Webster, Inc., Springfield, MA, 2003.

2.4 References for Extracts in Mandatory Sections.

NFPA 1, *Fire Code*, 2015 edition.

NFPA 13, *Standard for the Installation of Sprinkler Systems*, 2016 edition.

NFPA 51B, *Standard for Fire Prevention During Welding, Cutting, and Other Hot Work*, 2014 edition.

NFPA 72®, *National Fire Alarm and Signaling Code*, 2016 edition.

NFPA 90A, *Standard for the Installation of Air-Conditioning and Ventilating Systems*, 2015 edition.

NFPA 101®, *Life Safety Code®*, 2015 edition.

NFPA 731, *Standard for the Installation of Electronic Premises Security Systems*, 2017 edition.

NFPA 805, *Performance-Based Standard for Fire Protection for Light Water Reactor Electric Generating Plants*, 2015 edition.

NFPA 914, *Code for Fire Protection of Historic Structures*, 2015 edition.

NFPA 921, *Guide for Fire and Explosion Investigations*, 2017 edition.

NFPA 1141, *Standard for Fire Protection Infrastructure for Land Development in Wildland, Rural, and Suburban Areas*, 2017 edition.

NFPA 1451, *Standard for a Fire and Emergency Service Vehicle Operations Training Program*, 2013 edition.

NFPA 5000®, *Building Construction and Safety Code®*, 2015 edition.

Chapter 3 Definitions

3.1 General. The definitions contained in this chapter shall apply to the terms used in this code. Where terms are not defined in this chapter or within another chapter, they shall be defined using their ordinarily accepted meanings within the context in which they are used. *Merriam-Webster's Collegiate Dictionary*, 11th edition, shall be the source for the ordinarily accepted meaning.

3.2 NFPA Official Definitions.

3.2.1* Approved. Acceptable to the authority having jurisdiction.

3.2.2* Authority Having Jurisdiction (AHJ). An organization, office, or individual responsible for enforcing the requirements of a code or standard, or for approving equipment, materials, an installation, or a procedure.

3.2.3* Code. A standard that is an extensive compilation of provisions covering broad subject matter or that is suitable for adoption into law independently of other codes and standards.

3.2.4* Listed. Equipment, materials, or services included in a list published by an organization that is acceptable to the authority having jurisdiction and concerned with evaluation of products or services, that maintains periodic inspection of production of listed equipment or materials or periodic evaluation of services, and whose listing states that either the equipment, material, or service meets appropriate designated standards or has been tested and found suitable for a specified purpose.

3.2.5 Shall. Indicates a mandatory requirement.

3.2.6 Should. Indicates a recommendation or that which is advised but not required.

3.2.7 Standard. An NFPA Standard, the main text of which contains only mandatory provisions using the word “shall” to indicate requirements and that is in a form generally suitable for mandatory reference by another standard or code or for adoption into law. Nonmandatory provisions are not to be considered a part of the requirements of a standard and shall be located in an appendix, annex, footnote, informational note, or other means as permitted in the NFPA Manuals of Style. When used in a generic sense, such as in the phrase “standards development process” or “standards development activities,” the term “standards” includes all NFPA Standards, including Codes, Standards, Recommended Practices, and Guides.

3.3 General Definitions.

3.3.1 Addition. An increase in the building area, aggregate floor area, height, or number of stories of a structure.

3.3.2 Alter/Alteration. A modification, replacement, or other physical change to an existing facility. [5000, 2015]

3.3.3 Analysis.

3.3.3.1 Sensitivity Analysis. An analysis performed to determine the degree to which a predicted output will vary given a specified change in an input parameter, usually in relation to models. [101, 2015]

3.3.3.2 Uncertainty Analysis. An analysis performed to determine the degree to which a predicted value will vary. [101, 2015]

3.3.4 Arson. The crime of maliciously and intentionally, or recklessly, starting a fire or causing an explosion. [921, 2017]

3.3.5 Barrier.

3.3.5.1 Fire Barrier. A continuous membrane or a membrane with discontinuities created by protected openings with a specified fire protection rating, where such membrane is designed and constructed with a specified fire resistance rating to limit the spread of fire. [101, 2015]

3.3.5.2 Smoke Barrier. A continuous membrane, or a membrane with discontinuities created by protected openings, where such membrane is designed and constructed to restrict the movement of smoke. [5000, 2015]

3.3.6 Book Stack. Shelving dedicated to the storage of library materials.

3.3.6.1* Multi-Tier Book Stack. A system of back-to-back metal (steel or wrought iron) bracket shelving stacked by being bolted together into multiple levels or tiers at approximately 7 ft (2.1336 m) intervals to form a book stack with walkways for each tier suspended from the posts or columns supporting the bracket shelving sections in each range.

3.3.6.2 Single-Tier Book Stack. Freestanding bracket, cantilever, or case shelving enclosed on one floor by a fire compartment.

3.3.7* Buildings. Structures, usually enclosed by walls and a roof, constructed to provide support or shelter for an intended occupancy. [5000, 2015]

3.3.7.1 Existing Building. A building erected or officially authorized prior to the effective date of the adoption of this edition of the code by the agency or jurisdiction. [101, 2015]

3.3.8 Character-Defining Feature. A prominent or distinctive aspect, quality, or characteristic of a cultural resource property that contributes significantly to its physical character.

3.3.9 Collections. Prehistoric, historic, or religious objects, works of art, scientific specimens, archival documents, archeological sites and artifacts, library media, and cultural materials assembled according to some rational scheme and maintained for the purpose of preservation, research, study, exhibition, publication, or interpretation.

3.3.10 Collections Storage Room. An enclosure providing a safe and secure environment for collections including vaults and bookstacks.

3.3.11 Combination System. See 3.3.83.1.

3.3.12 Compact Storage Module. An assembly of shelving sections mounted on carriages with the arrangement of carriages on tracks so as to provide one moving aisle serving multiple carriages between fixed end ranges. [See Figure H.1(a) and Figure H.1(b).]

3.3.13 Compact Storage System. A storage installation composed of multiple compact storage modules. [See Figure H.1(c).]

3.3.14 Compartment. See 3.3.24.

3.3.15 Compliance. Adherence or conformance to laws and standards. [914, 2015]

3.3.15.1 Compliance Audit. An examination or inspection by the authority having jurisdiction or a designee to verify adherence to or conformance with design features and management programs required for the building to continue to satisfy the provisions of an approved performance-based alternative to a prescriptive code requirement.

3.3.16 Conservation. The professional practice of examination, documentation, treatment, and preventative care devoted to the preservation of a cultural resource property.

3.3.17* Cultural Resource Properties. Buildings, structures, or sites, or portions thereof, that are culturally significant or that house culturally significant collections for museums, libraries, and places of worship.

3.3.18 Damage Limitation. Written procedures that outline and prioritize the actions to take following a disaster to minimize property damage and loss.

3.3.19 Design Specification. A building characteristic and other conditions that are under the control of the design team. [5000, 2015]

3.3.20 Design Team. A group of stakeholders including, but not limited to, representatives of the architect, client, and any pertinent engineers and other designers. [101, 2015]

3.3.21 Electronic Premises Security System. See 3.3.83.2.

3.3.22 Exposure Fire. A fire that starts at a location that is remote from the area being protected and grows to expose that which is being protected. [101, 2015]

3.3.23 Fire Alarm System. See 3.3.83.3.

3.3.24 Fire Compartment. A space within a building that is enclosed by fire barriers on all sides, including the top and bottom. [101, 2015]

3.3.25 Fire Hazard. Any situation, process, material, or condition that, on the basis of applicable data, can cause a fire or explosion or provide a ready fuel supply to augment the spread or intensity of a fire or explosion, all of which pose a threat to life or property.

3.3.26 Fire Model. Mathematical prediction of fire growth, environmental conditions, and potential effects on structures, systems, or components based on the conservation equations or empirical data. [805, 2015]

3.3.27 Fire Protection System. See 3.3.83.4.

3.3.28 Fire Resistance Rating. The time, in minutes or hours, that materials or assemblies have withstood a fire exposure as established in accordance with the test procedures of ASTM E119 or ANSI/UL 263.

3.3.29* Fire Retardant. A liquid, solid, or gas that tends to inhibit combustion when applied on, mixed in, or combined with combustible materials. [1, 2015]

3.3.30* Fire Safety Manager. A person identified by the governing body who is responsible for developing, implementing, exercising, and conducting routine evaluations of fire safety provisions of the code.

3.3.31 Firestop. A specific system, device, or construction consisting of the materials that fill the openings around penetrating items such as cables, cable trays, conduits, ducts, pipes, and their means of support through the wall or floor openings to prevent the spread of fire. [5000, 2015]

3.3.32 Fire Watch. The assignment of a person or persons to an area for the express purpose of notifying the fire department, the building occupants, or both, of an emergency; preventing a fire from occurring; extinguishing small fires; or protecting the public from fire or life safety dangers. [1, 2015]

3.3.33 Fuel Load. The total quantity of combustible contents of a building, space, or fire area, including interior finish and trim, expressed in heat units of the equivalent weight in wood. [921, 2017]

3.3.34 Goal. A nonspecific overall outcome to be achieved that is measured on a qualitative basis. [101, 2015]

3.3.35 Governing Body. The board of directors, trustees, owner, or other body charged with governance and fiduciary responsibility of a cultural resource property.

3.3.36 Hazard. A condition or a physical situation with a potential for loss or damage.

3.3.37* Hazardous Area. An area of a structure or building that poses a degree of hazard greater than that normal to the general occupancy of the building or structure. [5000, 2015]

3.3.38 Historic Fabric. Original or added building or construction materials, features, and finishes that existed during the period that is deemed to be most architecturally or historically significant, or both.

3.3.39* Historic Structure. A building, bridge, lighthouse, monument, pier, vessel, or other construction that is designa-

ted or that is deemed eligible for such designation by a local, regional, or national jurisdiction as having historic, architectural, or cultural significance.

3.3.40 Hot Work. Work involving burning, welding, or a similar operation that is capable of initiating fires or explosions. [51B, 2014]

3.3.41* Impairment. An abnormal condition, during either a planned or emergency event, where a system, component, or function is inoperable. [72, 2016]

3.3.42* Incendiary Fire. A fire that has been deliberately ignited under circumstances in which the person knows the fire should not be ignited.

3.3.43 Initiating Device. A system component that originates transmission of a change-of-state condition, such as in a smoke detector, manual fire alarm box, or supervisory switch. [72, 2016]

3.3.44 Input Data Specification. Information required by the verification method. [101, 2015]

3.3.45* Library. Any building or place in which books and other media are kept for reading, reference, research, or lending.

3.3.46 Limited-Combustible Material. See 9.12.7.2.

3.3.47* Management Operational Systems. Management initiatives, such as oversight and intervention, planning, and staff training used as an element in achieving compliance with prescriptive or performance-based code solutions.

3.3.48 Means of Egress. A continuous and unobstructed way of travel from any point in a building or structure to a public way consisting of three separate and distinct parts: (1) the exit access, (2) the exit, and (3) the exit discharge. [101, 2015]

3.3.49 Modification. The reconfiguration of any space, the addition or elimination of any door or window, the addition or elimination of load-bearing elements, the reconfiguration or extension of any system, or the installation of any additional equipment. [5000, 2015]

3.3.50* Museum. An institution that acquires, conserves, researches, communicates, and exhibits material evidence of people and their environment for purposes of study, education, and enjoyment.

3.3.51 Noncombustible Material. See 9.12.7.1.

3.3.52 Notification Appliance. A fire alarm system component such as a bell, horn, speaker, light, or text display, that provides audible, tactile, or visible outputs, or any combination thereof. [72, 2016]

3.3.53 Objective. A requirement that needs to be met to achieve a goal. [101, 2015]

3.3.54 Occupancy. The purpose for which a building or other structure, or part thereof, is used or intended to be used. [5000, 2015]

3.3.55 Occupant Characteristics. The abilities or behaviors of people before and during a fire. [101, 2015]

3.3.56 Occupant Load. The total number of persons that might occupy a building or portion thereof at any one time. [5000, 2015]

3.3.57 Performance-Based Design Approach. A design process where fire safety solutions are designed to achieve a specified goal for a specified use or application.

3.3.58 Performance Criteria. Threshold values on measurement scales that are based on quantified performance objectives. [101, 2015]

3.3.59 Place of Worship. Any building that functions primarily as a group meeting place for the practice of religion, which includes, but is not limited to, churches, synagogues, cathedrals, temples, mosques, and meeting halls.

3.3.60 Plenum. A compartment or chamber to which one or more air ducts are connected and that forms part of the air distribution system. [90A, 2015]

3.3.61 Preservation. The act or process of applying measures necessary to sustain the existing form, integrity, and materials of a historic building or structure.

3.3.62 Private. Intended for or limited to the use of some particular person(s) or group.

3.3.63 Project Team. A group of stakeholders including, but not limited to, representatives of architects, clients, engineers and designers, authorities having jurisdiction, and preservation specialists.

3.3.64 Proposed Design. A design developed by a design team and submitted to the authority having jurisdiction for approval. [101, 2015]

3.3.65 Protected Premises. The physical location protected by a fire alarm system, fire suppression system, electronic premises protection system, or other type of protection system.

3.3.66 Protection. Features, systems, and programs implemented to prevent or minimize loss from fire, arson, vandalism, theft, natural disasters, disruptive events, and similar hazards to property, collections, or operations.

3.3.67 Public. Of, pertaining to, or affecting a population or a community as a whole; open to all persons.

3.3.68 Rehabilitation. For the purpose of this code, the act or process of making possible a compatible use of a property through repair, alteration, and additions, while preserving those portions or features that convey its historic, cultural, or architectural value.

3.3.69 Renovation. The replacement in kind, strengthening or upgrading of building elements, materials, equipment, or fixtures that does not result in a reconfiguration of the building or spaces within. [5000, 2015]

3.3.70 Restoration. The act or process of accurately depicting the form, features, and character of a property as it appeared at a particular period of time by means of the removal of features from other periods of its history, reconstruction of missing features from the restoration period, and repair of damaged or altered features from the restoration period.

3.3.71 Risk. A measure of the probability and severity of adverse effects that result from exposure to a hazard. [1451, 2013]

3.3.72 Safety Factor. A factor applied to a predicted value to ensure that a sufficient safety margin is maintained. [101, 2015]

3.3.73 Safety Margin. The difference between a predicted value and the actual value where a fault condition is expected. [101, 2015]

3.3.74 Scenario. Set of circumstances and/or an order of events in an incident that is feasible and reasonably foreseeable.

3.3.74.1 Design Fire Scenario. A fire scenario selected for evaluation of a proposed design.

3.3.74.2* Fire Scenario. A set of conditions that defines the development of fire, the spread of combustion products throughout a building or portion of a building, the reactions of people to fire, and the effects of combustion products. [101, 2015]

3.3.75 Secondary Storage. Storage separate from the main collections, usually of low use library collections.

3.3.76 Security. The quality or state of relieving from exposure to danger, acting to make safe against adverse contingencies, or taking measures to guard against hazards, including, but not limited to, accidents, deliberate acts, natural disasters, or other conditions or physical situations with the potential to cause damage or loss.

3.3.77 Security Manager. A person identified by the governing body who is responsible for developing, implementing, exercising, and conducting routine evaluations of security provisions of the code.

3.3.78 Smoke Detector. A device that detects visible or invisible particles of combustion. [72, 2016]

3.3.79* Special Event. Any activity outside of the normal daily operations.

3.3.80 Sprinkler System. See 3.3.83.5.

3.3.81 Stakeholder. An individual, or representative of same, having an interest in the successful completion of a project. [101, 2015]

3.3.82 Structure. That which is built or constructed and limited to buildings and nonbuilding structures as defined herein. [5000, 2015]

3.3.83 System.

3.3.83.1 Combination System (as related to premises security). A system that provides premises security as a portion of a single control unit, or multiple control units that work together to provide one integrated control. [731, 2017]

3.3.83.2 Electronic Premises Security System. A system or portion of a combination system that consists of components and circuits arranged to monitor or control activity at or access to a protected premises. [731, 2017]

3.3.83.3 Fire Alarm System. A system or portion of a combination system consisting of components and circuits arranged to monitor and annunciate the status of fire alarm or supervisory signal-initiating devices and to initiate the appropriate response to those signals. [72, 2016]

3.3.83.4 Fire Protection System. Any fire alarm device or system, or fire extinguishing device or system, or combination thereof, that is designed and installed for detecting, controlling, or extinguishing a fire or otherwise alerting

occupants, or the fire department, or both, that a fire has occurred. [1141, 2017]

3.3.83.5 Sprinkler System. A system that consists of an integrated network of piping designed in accordance with fire protection engineering standards that includes a water supply source, a water control valve, a waterflow alarm, and a drain. The portion of the sprinkler system above ground is a network of specifically sized or hydraulically designed piping installed in a building, structure, or area, generally overhead, and to which sprinklers are attached in a systematic pattern. The system is commonly activated by heat from a fire and discharges water over the fire area. [13, 2016]

3.3.84* Utilities. Building service control and distribution systems and their associated equipment, pipes, ducts, wires, and cables.

3.3.85 Verification Method. A procedure or process used to demonstrate or confirm that the proposed design meets the specified criteria. [101, 2015]

3.3.86 Vertical Opening. An opening through a floor or roof. [101, 2015]

Chapter 4 Goals and Objectives

4.1 General. The governing body of the cultural resource property shall adopt protection goals and objectives that reflect the acceptable level of loss for both of the following:

- (1) Items of cultural significance
- (2) Interruption of service to the client community

4.2 Goals.

4.2.1 Collection Preservation. The collection preservation goal of this code shall be to provide a reasonable level of protection for collections against conditions or physical situations with the potential to cause damage or loss, including, but not limited to, fire, products of combustion, and fire suppression agents and activities; deliberate actions of third parties, staff, or visitors; or natural disasters.

4.2.2 Building Preservation. The building preservation goal of this code shall be to provide a reasonable level of protection for buildings, their unique characteristics, and their fabric against conditions or physical situations with the potential to cause damage or loss, including, but not limited to, fire, products of combustion, and fire suppression agents and activities; deliberate actions of third parties, staff, or visitors; or natural disasters.

4.2.3 Continuity of Operations. The continuity of operations goal of this code shall be to provide a reasonable level of protection against disruption of facility operations consistent with the organization's mission and protection goals.

4.3* Objectives.

4.3.1 Collection Preservation. Protection features, systems, and programs shall be designed, approved, implemented, and maintained to protect and preserve the original qualities of the collection.

4.3.1.1 Structural integrity shall be maintained to protect items in the collections that are not intimate with the initiating event for the time needed to evacuate, relocate, or defend them in place.

4.3.1.2 Access for emergency responders shall be provided for the time specified in 4.3.1.1 to evacuate, relocate, or defend collection objects in place.

4.3.2 Building Preservation.

4.3.2.1 Protection features, systems, and programs shall be designed, approved, installed, and maintained to preserve the original qualities or character of a building, structure, site, or environment.

4.3.2.2 Removal or alteration of any distinctive architectural features for the purpose of improving fire protection or life safety shall be minimized.

4.3.3 Continuity of Operations. Protection features, systems, and programs shall be designed, approved, implemented, and maintained to minimize disruption of operations consistent with the cultural resource property's mission and protection goals.

Chapter 5 Protection Plan

5.1* General.

5.1.1* The governing body of a cultural resource property shall adopt a protection plan that addresses operations during conditions or physical situations with the potential to cause damage or loss including, but not limited to, the following:

- (1) Fires
- (2) Deliberate acts of third parties, staff, or visitors
- (3) Other disruptive or potentially adverse events including, but not limited to, the following:
 - (a) Severe weather
 - (b) Earthquake
 - (c) Loss of communications
 - (d) Failure of critical building systems
 - (e) Flood
 - (f) Loss of utilities (gas, electricity, water, etc.)

5.1.2 The protection plan shall include, but shall not be limited to, components covering operations developed in compliance with Chapter 6, fire safety management developed in compliance with Chapter 7, and security developed in compliance with Chapter 8.

5.2 Responsibilities of Governing Body.

5.2.1 The governing body shall provide stewardship to care for and to protect the items of cultural significance entrusted to it (*see 5.3.2*).

5.2.2 The governing body shall confer with the authority having jurisdiction or the planning team (*see 5.3.2*).

5.2.3* The governing body shall be responsible for the conduct of the vulnerability assessment of the cultural resource property.

5.2.4* The governing body shall define the goals and objectives developed in compliance with Sections 4.2 and 4.3.

5.2.5 The governing body shall establish the loss tolerability thresholds for the cultural resource property.

5.2.6 The governing body shall evaluate the results of the vulnerability assessment against the loss tolerability thresholds

and develop protection strategies to mitigate the risks that could prevent achieving the goals and objectives.

5.2.7 The governing body shall oversee the development of a protection plan to eliminate, manage, or control risks identified as exceeding the tolerability thresholds established in compliance with 5.3.8.2 to achieve the protection goals and objectives developed in compliance with Sections 4.2 and 4.3.

5.2.8* Organization. The governing body shall identify a person or persons responsible for protection of the cultural resource property, its contents, collections, and operations.

5.3 Planning Process.

5.3.1 General. The process for developing the protection plan shall comply with 5.3.2 through 5.3.8 and Figure 5.3.1.

5.3.2 Planning Team.

5.3.2.1 The governing body shall identify a planning team to oversee the development of the protection plan for the cultural resource property.

5.3.2.2* The planning team shall have expertise in cultural resource property preservation and protection and demonstrated knowledge and understanding of the culturally significant elements of the structure and its collections.

5.3.3 Collect Information.

5.3.3.1 Codes, Standards, and Regulations. The planning team shall review all fire safety and security-related codes, standards, and regulations to identify requirements applicable to the cultural resource property.

5.3.3.2* Survey. The planning team shall conduct a detailed survey of the facility's operations, building protection features, and the culturally significant features of the structure and collection.

5.3.3.2.1 Structure.

5.3.3.2.1.1* Exterior. The building survey shall identify those character-defining features and finishes that make the exterior of the building significant.

5.3.3.2.1.2* Interior. The building survey shall identify all significant interior spaces, floor plan organization, and character-defining features and finishes in the building.

5.3.3.2.2 Collections. The survey shall identify all significant collections, archives, and other contents of cultural significance, their location, and any unique vulnerability to damage or loss.

5.3.3.2.3 Operations. The planning team shall identify the facility's client community and the effect of a disruption of operations on the delivery of service to that community, including those that impact business generating revenue.

5.3.4 Prioritization of Significant Elements, Collections, and Operations. The planning team shall determine primary and secondary significance of all culturally significant elements, collections, or both, and the primary and secondary operational priorities for the facility.

5.3.5* Potential Threat Identification.

5.3.5.1 The planning team shall identify conditions that could contribute to the loss or damage of property (structure or collections) by fire; foreseeable crimes; deliberate acts of third

parties, staff, or visitors; or other events with the potential to cause damage or loss.

5.3.5.2 Potential threats shall include but not be limited to those listed in Figure 5.3.5.2, and their identification shall be conducted in accordance with that checklist.

5.3.6* Tolerability Evaluation. The planning team shall evaluate the tolerability of potential threats identified in 5.3.5 based on the cultural resource property's protection goals and objectives developed in compliance with Sections 4.2 and 4.3, the assessment of likelihood of occurrence and potential severity required in Figure 5.3.5.2, and the tolerability thresholds developed in compliance with 5.2.5.

5.3.7* Loss Scenarios. Potential loss scenarios shall be considered for all intolerable threats identified in 5.3.6.

5.3.8 Risk Analysis.

5.3.8.1 The loss scenarios identified in compliance with 5.3.7 shall be evaluated with respect to their potential frequency and severity of the conditions identified.

5.3.8.2 The planning team shall determine risk tolerability by a comparison of the risk identified from the loss scenarios developed in 5.3.7 with the goals and objectives developed in compliance with Sections 4.2 and 4.3 and the tolerability thresholds developed in compliance with 5.2.5.

5.4 Protection Plan Components.

5.4.1 The protection plan shall include provisions for each category of events identified in the vulnerability assessment required in 5.2.3 that exceeds the tolerability thresholds established by the governing body.

5.4.2 Planning for each category of event shall include provisions for all of the following as applicable to the event:

- (1) Preparation for incident/event/threat
- (2) Prevention of incident
- (3) Notification of incident
- (4) Verification of incident
- (5) Response to incident
- (6) Assessment of potential damage
- (7) Mitigation/limitation of damage
- (8) Recovery of collections and buildings from incident
- (9) Post-emergency evaluation of the protection plan

5.4.3 The protection plan shall be in writing and shall be approved by the governing body.

5.5 Protection Plan Evaluation.

5.5.1 The governing body shall develop performance criteria to measure the effectiveness of the protection plan.

5.5.2 Protection plan performance shall be evaluated against the performance criteria whenever significant changes occur but no less than annually.

5.5.3 The fire safety manager and the security manager identified in compliance with Section 10.2 shall have the authority to develop, implement, exercise, and conduct routine evaluations of the protection plan and its emergency operations component.

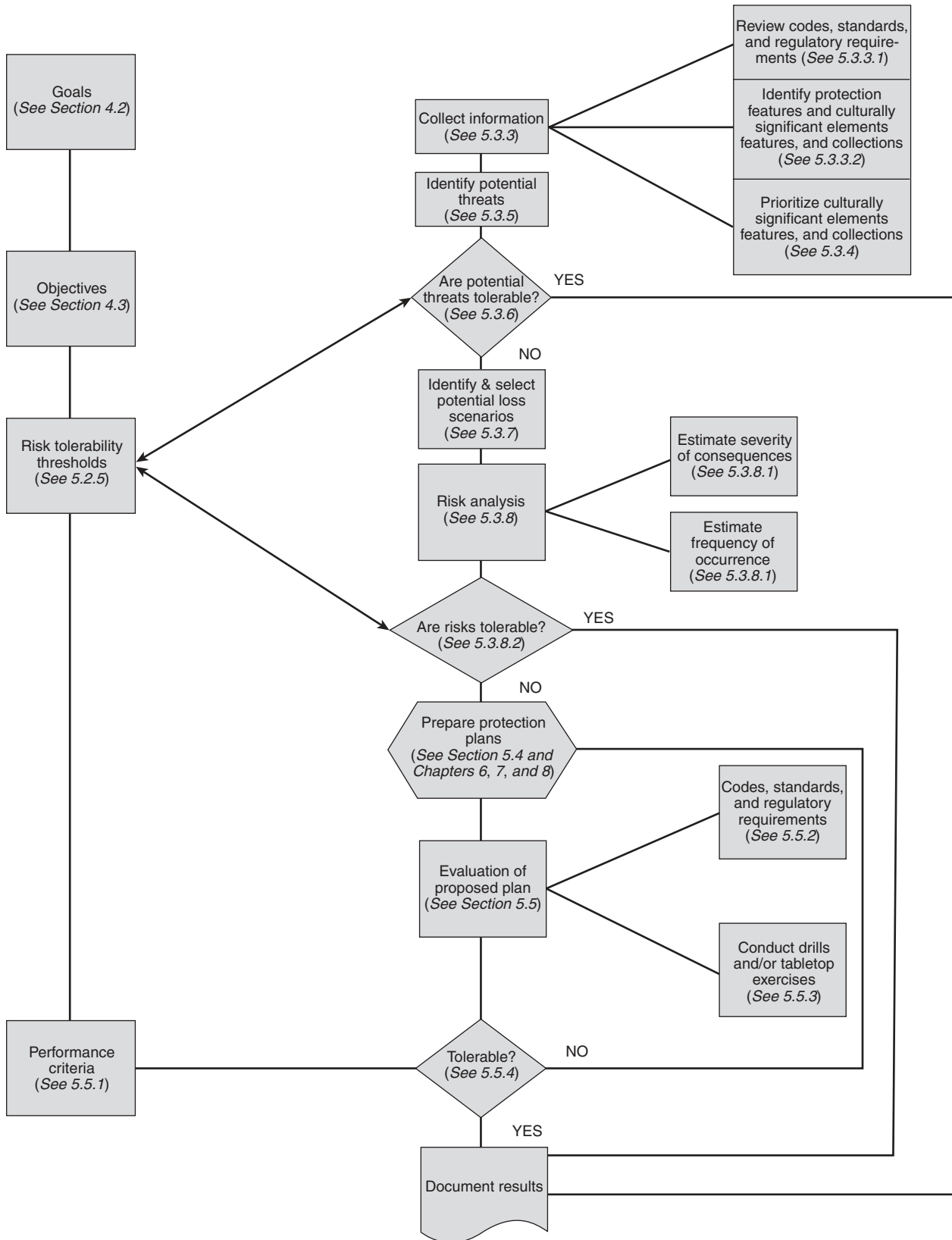

FIGURE 5.3.1 Planning Flow Chart.

POTENTIAL THREATS ASSESSMENT								
	N/A	Likelihood of Occurrence			Potential Severity			
		Low	Moderate	High	Low	Moderate	High	
Unintentional Act								
Fire/explosion	<input type="checkbox"/>	<input type="checkbox"/>	<input type="checkbox"/>	<input type="checkbox"/>	<input type="checkbox"/>	<input type="checkbox"/>	<input type="checkbox"/>	<input type="checkbox"/>
Health emergency	<input type="checkbox"/>	<input type="checkbox"/>	<input type="checkbox"/>	<input type="checkbox"/>	<input type="checkbox"/>	<input type="checkbox"/>	<input type="checkbox"/>	<input type="checkbox"/>
Hazardous material spill or release	<input type="checkbox"/>	<input type="checkbox"/>	<input type="checkbox"/>	<input type="checkbox"/>	<input type="checkbox"/>	<input type="checkbox"/>	<input type="checkbox"/>	<input type="checkbox"/>
Transportation accident	<input type="checkbox"/>	<input type="checkbox"/>	<input type="checkbox"/>	<input type="checkbox"/>	<input type="checkbox"/>	<input type="checkbox"/>	<input type="checkbox"/>	<input type="checkbox"/>
Intentional Act								
Terrorism	<input type="checkbox"/>	<input type="checkbox"/>	<input type="checkbox"/>	<input type="checkbox"/>	<input type="checkbox"/>	<input type="checkbox"/>	<input type="checkbox"/>	<input type="checkbox"/>
Cyber attack	<input type="checkbox"/>	<input type="checkbox"/>	<input type="checkbox"/>	<input type="checkbox"/>	<input type="checkbox"/>	<input type="checkbox"/>	<input type="checkbox"/>	<input type="checkbox"/>
Arson	<input type="checkbox"/>	<input type="checkbox"/>	<input type="checkbox"/>	<input type="checkbox"/>	<input type="checkbox"/>	<input type="checkbox"/>	<input type="checkbox"/>	<input type="checkbox"/>
Theft	<input type="checkbox"/>	<input type="checkbox"/>	<input type="checkbox"/>	<input type="checkbox"/>	<input type="checkbox"/>	<input type="checkbox"/>	<input type="checkbox"/>	<input type="checkbox"/>
Vandalism	<input type="checkbox"/>	<input type="checkbox"/>	<input type="checkbox"/>	<input type="checkbox"/>	<input type="checkbox"/>	<input type="checkbox"/>	<input type="checkbox"/>	<input type="checkbox"/>
Sabotage	<input type="checkbox"/>	<input type="checkbox"/>	<input type="checkbox"/>	<input type="checkbox"/>	<input type="checkbox"/>	<input type="checkbox"/>	<input type="checkbox"/>	<input type="checkbox"/>
Civil disturbance, public unrest, mass hysteria, riot	<input type="checkbox"/>	<input type="checkbox"/>	<input type="checkbox"/>	<input type="checkbox"/>	<input type="checkbox"/>	<input type="checkbox"/>	<input type="checkbox"/>	<input type="checkbox"/>
Strike	<input type="checkbox"/>	<input type="checkbox"/>	<input type="checkbox"/>	<input type="checkbox"/>	<input type="checkbox"/>	<input type="checkbox"/>	<input type="checkbox"/>	<input type="checkbox"/>
System Failure								
Loss of electricity	<input type="checkbox"/>	<input type="checkbox"/>	<input type="checkbox"/>	<input type="checkbox"/>	<input type="checkbox"/>	<input type="checkbox"/>	<input type="checkbox"/>	<input type="checkbox"/>
Water leak	<input type="checkbox"/>	<input type="checkbox"/>	<input type="checkbox"/>	<input type="checkbox"/>	<input type="checkbox"/>	<input type="checkbox"/>	<input type="checkbox"/>	<input type="checkbox"/>
Building collapse/structural failure	<input type="checkbox"/>	<input type="checkbox"/>	<input type="checkbox"/>	<input type="checkbox"/>	<input type="checkbox"/>	<input type="checkbox"/>	<input type="checkbox"/>	<input type="checkbox"/>
Fuel shortage	<input type="checkbox"/>	<input type="checkbox"/>	<input type="checkbox"/>	<input type="checkbox"/>	<input type="checkbox"/>	<input type="checkbox"/>	<input type="checkbox"/>	<input type="checkbox"/>
Communications system interruption	<input type="checkbox"/>	<input type="checkbox"/>	<input type="checkbox"/>	<input type="checkbox"/>	<input type="checkbox"/>	<input type="checkbox"/>	<input type="checkbox"/>	<input type="checkbox"/>
Air/water pollution contamination	<input type="checkbox"/>	<input type="checkbox"/>	<input type="checkbox"/>	<input type="checkbox"/>	<input type="checkbox"/>	<input type="checkbox"/>	<input type="checkbox"/>	<input type="checkbox"/>
Water control structure, dam, or levee failure	<input type="checkbox"/>	<input type="checkbox"/>	<input type="checkbox"/>	<input type="checkbox"/>	<input type="checkbox"/>	<input type="checkbox"/>	<input type="checkbox"/>	<input type="checkbox"/>
HVAC system failure	<input type="checkbox"/>	<input type="checkbox"/>	<input type="checkbox"/>	<input type="checkbox"/>	<input type="checkbox"/>	<input type="checkbox"/>	<input type="checkbox"/>	<input type="checkbox"/>
Loss of protection systems	<input type="checkbox"/>	<input type="checkbox"/>	<input type="checkbox"/>	<input type="checkbox"/>	<input type="checkbox"/>	<input type="checkbox"/>	<input type="checkbox"/>	<input type="checkbox"/>
Geological								
Earthquake	<input type="checkbox"/>	<input type="checkbox"/>	<input type="checkbox"/>	<input type="checkbox"/>	<input type="checkbox"/>	<input type="checkbox"/>	<input type="checkbox"/>	<input type="checkbox"/>
Tsunami	<input type="checkbox"/>	<input type="checkbox"/>	<input type="checkbox"/>	<input type="checkbox"/>	<input type="checkbox"/>	<input type="checkbox"/>	<input type="checkbox"/>	<input type="checkbox"/>
Volcano	<input type="checkbox"/>	<input type="checkbox"/>	<input type="checkbox"/>	<input type="checkbox"/>	<input type="checkbox"/>	<input type="checkbox"/>	<input type="checkbox"/>	<input type="checkbox"/>
Landslide/mudslide	<input type="checkbox"/>	<input type="checkbox"/>	<input type="checkbox"/>	<input type="checkbox"/>	<input type="checkbox"/>	<input type="checkbox"/>	<input type="checkbox"/>	<input type="checkbox"/>
Biological								
Pandemic disease	<input type="checkbox"/>	<input type="checkbox"/>	<input type="checkbox"/>	<input type="checkbox"/>	<input type="checkbox"/>	<input type="checkbox"/>	<input type="checkbox"/>	<input type="checkbox"/>
Animal or insect infestation	<input type="checkbox"/>	<input type="checkbox"/>	<input type="checkbox"/>	<input type="checkbox"/>	<input type="checkbox"/>	<input type="checkbox"/>	<input type="checkbox"/>	<input type="checkbox"/>
Meteorological								
Flood, flash flood, seiche, tidal surge	<input type="checkbox"/>	<input type="checkbox"/>	<input type="checkbox"/>	<input type="checkbox"/>	<input type="checkbox"/>	<input type="checkbox"/>	<input type="checkbox"/>	<input type="checkbox"/>
Drought	<input type="checkbox"/>	<input type="checkbox"/>	<input type="checkbox"/>	<input type="checkbox"/>	<input type="checkbox"/>	<input type="checkbox"/>	<input type="checkbox"/>	<input type="checkbox"/>
Wildland fire (forest, brush, grass, ground)	<input type="checkbox"/>	<input type="checkbox"/>	<input type="checkbox"/>	<input type="checkbox"/>	<input type="checkbox"/>	<input type="checkbox"/>	<input type="checkbox"/>	<input type="checkbox"/>
Snow, ice, hail, sleet, avalanche	<input type="checkbox"/>	<input type="checkbox"/>	<input type="checkbox"/>	<input type="checkbox"/>	<input type="checkbox"/>	<input type="checkbox"/>	<input type="checkbox"/>	<input type="checkbox"/>
Windstorm, tropical cyclone, hurricane, tornado, water spout, dust/sand storm	<input type="checkbox"/>	<input type="checkbox"/>	<input type="checkbox"/>	<input type="checkbox"/>	<input type="checkbox"/>	<input type="checkbox"/>	<input type="checkbox"/>	<input type="checkbox"/>
Extreme heat/cold	<input type="checkbox"/>	<input type="checkbox"/>	<input type="checkbox"/>	<input type="checkbox"/>	<input type="checkbox"/>	<input type="checkbox"/>	<input type="checkbox"/>	<input type="checkbox"/>
Lightning	<input type="checkbox"/>	<input type="checkbox"/>	<input type="checkbox"/>	<input type="checkbox"/>	<input type="checkbox"/>	<input type="checkbox"/>	<input type="checkbox"/>	<input type="checkbox"/>

© 2016 National Fire Protection Association

NFPA 909

FIGURE 5.3.5.2 Potential Threats Assessment.

5.5.4 An evaluation of the protection plan shall include, but shall not be limited to, review of current codes, standards, and regulatory requirements, and conducting table-top exercises and partial or full-scale drills at regular intervals but no less than annually.

Chapter 6 Protection Plan — Emergency Operations

6.1 Developing Emergency Operations Procedures.

6.1.1* The planning team established in accordance with 5.3.2, sometimes referred to as an emergency management committee, shall have responsibility for developing the emergency operations component of the cultural resource property's protection plan. The emergency operations component of the protection plan shall be based on the assessment conducted in accordance with 5.2.3 and Section 5.4 and a realistic evaluation of the cultural resource property's protection and emergency management capabilities and resources.

6.1.2* The emergency operations component of the protection plan shall follow an incident command system (ICS) model to facilitate coordination with local emergency response agencies.

6.1.3* The emergency operations component of the protection plan shall specify the responsibilities and the organization of the response and recovery team.

6.2 Contents. The emergency operations component of the protection plan, as a minimum, shall include the applicable tasks detailed in Chapter 5.

6.3 Identification of Emergency Response Personnel.

6.3.1 All personnel designated or involved in emergency operations shall be supplied with a means of identification, which shall be visible at all times.

6.3.2 Specific means of identification for incident command system (ICS) personnel shall be provided, such as vests, baseball caps, or hard hats.

6.4 Continuity of Essential Building Systems. The emergency operations component of the protection plan shall include contingencies for the continuity of the following essential building systems, as required:

- (1) Electricity
- (2) Water
- (3) Heating, ventilation, air conditioning (HVAC)
- (4) Detection, suppression, and security systems
- (5) Fuel sources
- (6) Communication systems

6.5 Occupant Management. Planning shall include alerting, locating, and managing all staff and other occupants in an emergency, as well as consideration of all of the following:

- (1) Emergency response
- (2) Emergency evacuation
- (3) Emergency shelter
- (4) Temporary housing
- (5) Transportation of staff and other occupants
- (6) Critical incident stress management

6.6* Emergency Response Activities. The protection plan shall define emergency response activities.

6.6.1 The protection plan shall include provisions for notifying the fire department or other emergency responders of the type and location of the emergency and directing them to the incident location once they arrive.

6.6.2* The protection plan shall include provisions for posting emergency notification and response procedures for staff and other occupants. Emergency telephone numbers shall be posted on or adjacent to all telephones.

6.6.3 The protection plan shall include provisions for annual exercises to ensure effectiveness and include provisions to incorporate lessons learned from the exercises into the protection plan.

6.7 Developing Procedures for Removal or Relocation of Collections.

6.7.1 The emergency operations component of the protection plan shall include emergency evacuation procedures for collections and other items of cultural significance prepared in cooperation with the local fire department, other applicable authorities, or external vendors.

6.7.2 The emergency evacuation procedures shall include the following:

- (1) Provisions for normal operating conditions and for special events
- (2) Provisions for temporary and special exhibits
- (3) Provisions for training and drills to be conducted at intervals identified in the protection plan, but not less than annually
- (4) Provisions for staff training and drills to adjust for altered circumstances and increases in visitation during special events and exhibits
- (5) Provisions for notifying the local fire and security service in advance of special events that could affect the emergency evacuation procedures

6.8 Damage Limitation. The protection plan shall include a damage limitation component that shall comply with 6.8.1 through 6.8.12 and Figure 6.8.

6.8.1 Collection Inventory.

6.8.1.1* A periodic inventory of all items in a collection shall be conducted to verify their presence and condition.

6.8.1.2 The inventory shall account for all permanent collection objects, those on loan, and those in the temporary custody of the cultural resource property.

6.8.1.3* Inventory records shall include basic identifying information for each object, and shall include photographs or videos of objects.

6.8.1.4 Inventory records shall be securely stored and backed up, with a copy stored off-site.

6.8.2* Collection Vulnerability. The vulnerability assessment conducted in compliance with 5.2.3 shall consider the special hazards to objects in the collection.

6.8.2.1* The cultural resource property shall maintain a current list of all types of materials and media represented in its collections and a description of enclosures or storage furnishings in which collections are housed.

6.8.2.1.1 New acquisitions shall routinely be added to the list.

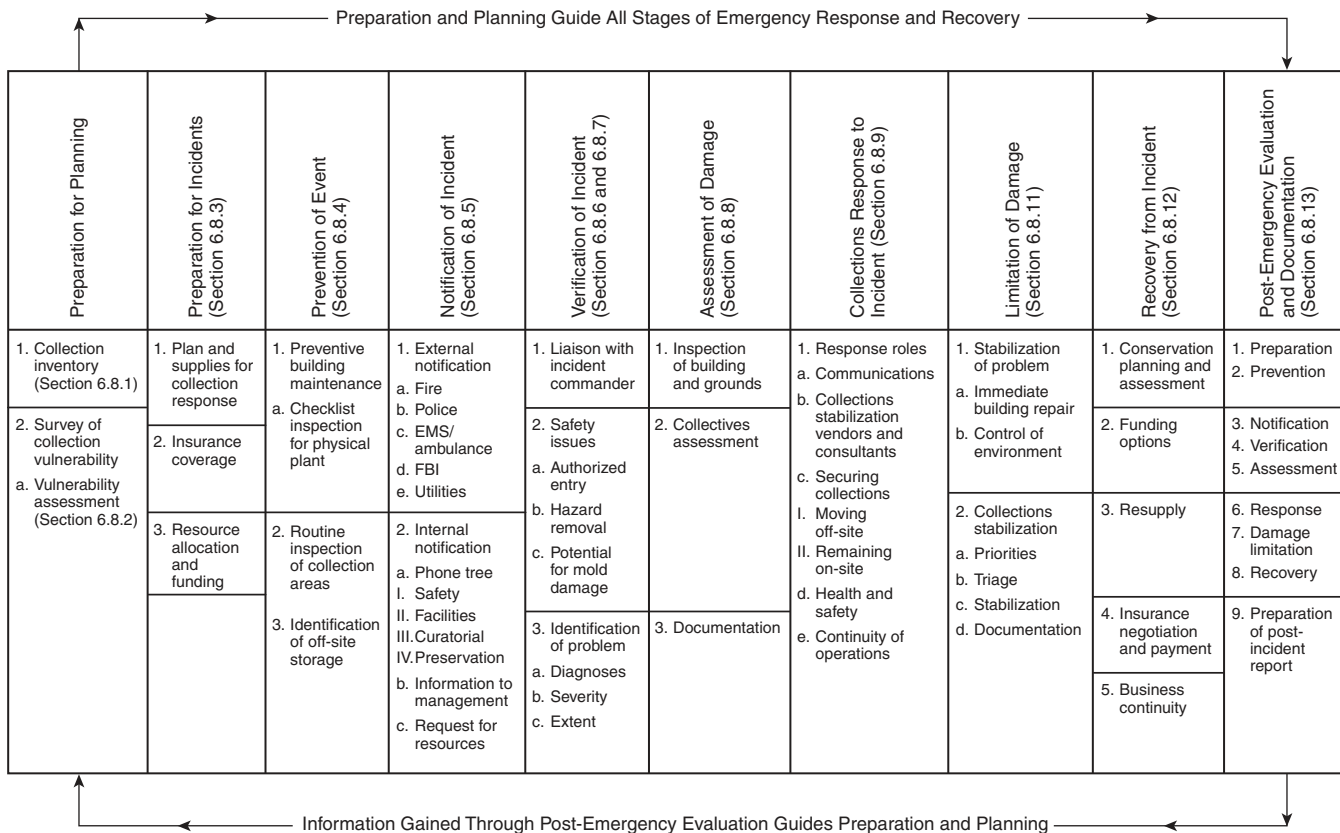

FIGURE 6.8 Damage Limitation.

6.8.2.1.2* Changes in storage locations or layout shall be reflected in the list.

6.8.2.2* The locations of any known prior and/or chronic water penetration or other infrastructure problems shall be documented.

6.8.2.3* In seismic zones, shelving and furniture shall be evaluated to assess seismic stability.

6.8.2.4* Below-grade and subterranean storage could place collections at higher risk. An assessment of off-site storage shall be conducted for the following:

- (1) Climate
- (2) Fire protection
- (3) Natural hazards
- (4) Security
- (5) Procedures for emergency recovery
- (6) Adjacent occupancies and utilities

6.8.2.5* The effects of water on each type of material represented within collections storage areas shall be evaluated.

6.8.3 Preparation for Incidents.

6.8.3.1* The protection plan shall identify collection objects of significance and shall include procedures to protect in place, evacuate, or recover those items.

6.8.3.2* A basic emergency response supply and equipment kit(s) shall be assembled and maintained.

6.8.3.3* A complete copy of all insurance documents shall be stored off-site.

6.8.3.4* **Resource Allocation and Funding.** The cultural resource property shall create and identify financial priorities for implementing protection measures.

6.8.4 Prevention of Event.

6.8.4.1* A written schedule for regular building inspections and maintenance shall be developed and implemented.

6.8.4.2 Chronic building problems, including areas vulnerable to water penetration, shall be identified.

6.8.4.2.1 Where collections are at risk, they shall be relocated.

6.8.4.2.2 If relocation is not possible, the collection shall be covered or otherwise protected until the vulnerability can be eliminated.

6.8.4.3 **Routine Inspection of Collection Areas.** Regular inspection of both on-site and off-site collection storage areas shall be performed to identify leaks, condensation, water stains, peeling paint, mold, and pests, unusual deposits of soot or particulate matter, and signs of physical damage such as cracks. The presence of any of these signs might indicate a building vulnerability that shall be addressed to prevent more significant problems in an emergency.

6.8.5 Notification of Incident.

6.8.5.1 The protection plan shall include a protocol for notifying external first responders and/or the emergency response team upon discovery of an undesirable event.

6.8.5.1.1 Each staff member of the cultural resource property shall have access to an up-to-date emergency call list that can be activated by any staff member upon discovery of an incident.

6.8.5.1.2* An emergency response team will coordinate response and recovery of cultural collections. Each team member shall have specific responsibilities, and there shall be an alternate for each position in the event that someone is unavailable to respond.

6.8.5.2 In the event of an emergency the individual who is first on the scene shall be responsible for notifying the emergency response team coordinator, and if that person is not available, the next responder on the telephone list until someone can be found to respond. The first responder shall act as the emergency team coordinator until the coordinator can reach the site.

6.8.6* Verification of Incident. Before implementing recovery activities, the emergency response team shall identify the problem and its source and determine its severity and the extent of damage in so far as it is safe and reasonable

6.8.7* Liaison with Incident Commander. Where a catastrophic event impacts multiple institutions or an entire locale, the cultural resource property shall name a member of the emergency response team to act as the institutional liaison to the local, state, or federal incident management team.

6.8.8 Assessment of Damage.

6.8.8.1* Collections Assessment. The emergency response team shall assess damage to collections.

6.8.8.2* Documentation. The protection plan shall include provisions for documentation of damage to collections.

6.8.9* Response Roles. Specific emergency response roles and responsibilities shall be assigned to response personnel from within (and/or outside of) the cultural resource property. Roles shall include, but shall not be limited to, the following:

- (1) Collections stabilization
- (2) Communication (internal and external)
- (3) Health and safety
- (4) Location of recovery effort (on- or off-site)
- (5) Securing collections
- (6) Vendors and consultants

6.8.10* Identification of Storage. The protection plan shall identify locations, on- and off-site, that can serve as temporary storage for evacuated collections and as a triage area for initial collection stabilization during a response.

6.8.11 Limitation of Damage.

6.8.11.1 Building Stabilization.

6.8.11.1.1 Damage to the building envelope that allows penetration of moisture and debris, or has compromised shelving, or other storage or exhibit furnishings shall be corrected as soon as possible to provide a stable area in which to house, inspect, or recover collections.

6.8.11.1.2* The collections storage or exhibit environment shall be controlled to prevent other additional damage such as the growth and spread of mold.

6.8.11.2* Collections Stabilization. The protection plan shall include measures for stabilization of at-risk collections.

6.8.12* Recovery from Incident. The protection plan shall include steps for recovery from the incident.

6.8.13* Post-Emergency Evaluation and Documentation. A written post-incident report shall be completed and shall be scaled to the magnitude of the incident.

6.9 Security.

6.9.1 The security component of the protection plan shall include provisions for protection of the cultural resource property's collections and buildings during emergencies.

6.9.2 The emergency operations component of the protection plan shall identify resources to implement emergency security activities that are sufficient to achieve the protection goals and objectives developed in compliance with Sections 4.2 and 4.3.

6.10 Public Affairs.

6.10.1 The governing body shall designate a media spokesperson to facilitate news releases during emergencies.

6.10.2 An area shall be designated where media representatives can be assembled, where they will not interfere with the operations of the cultural resource property, emergency response, and damage limitation activities, or endanger the collections.

6.11 Operational Recovery. The protection plan shall include measures to restore operational capability to pre-event levels. Fiscal aspects shall be considered because of restoration costs of the facility and its contents and possible cash flow losses associated with the disruption.

6.12 Staff Training.

6.12.1* The cultural resource property shall implement a training program that includes an overview of the protection plan and concepts of the incident command system.

6.12.2 Training on the protection plan and the incident command system shall be conducted at the time of hire. Site-specific training shall be conducted for employees upon reporting to their department or assuming their positions. All employees shall receive training annually thereafter.

6.12.3 Exercises. The cultural resource property shall conduct at least one drill of the emergency operations component of the protection plan annually.

6.13 Emergency Operations.

6.13.1 The decision to activate the emergency operations component of the protection plan shall be made by the designated response coordinator in accordance with the cultural resource property's activation criteria.

6.13.2 The decision to terminate emergency operations shall be made by the governing body or the designated authority in coordination with the response coordinator, the authority having jurisdiction, and other civil or military authorities involved. Provisions shall be made to notify all those involved in

the emergency operation that emergency operations have been terminated.

Chapter 7 Protection Plan — Fire Safety Management

7.1 Vulnerability Assessment.

7.1.1* A vulnerability assessment, conducted in accordance with 5.2.3 and Section 5.4, shall be used to develop the fire safety management component of the protection plan, and a copy of the assessment shall be attached to the protection plan. (See *Figure 5.3.1, Planning Flow Chart.*)

7.1.2 The vulnerability assessment shall include a survey to identify existing and potential fire hazards.

7.1.3 The survey shall include the following:

- (1) Identification of fire hazards inherent to the cultural resource property
- (2) Identification of conditions that increase the threat of arson (see 8.1.2)
- (3) Identification of fire risks and means-of-egress problems created by special events
- (4) An assessment of expected increases in visitation during special events, celebrations, and special exhibitions and procedures in place to identify and take action to prevent the number of occupants from exceeding building and means-of-egress capabilities
- (5) Identification of temporary or special exhibitions that can create special fire protection risks and means-of-egress problems or that can compromise existing fire protection systems
- (6) Identification of existing fire protection systems

7.1.4* The vulnerability assessment shall be used to establish priorities for correction of fire hazards identified in the survey based on the severity of the hazards and the difficulty and cost of abating them.

7.1.5 The vulnerability assessment shall identify where increased fire protection measures/systems are needed in order to achieve the protection goals and objectives developed in compliance with Sections 4.2 and 4.3.

7.2* Fire Safety Management.

7.2.1* General. The governing body of the cultural resource property shall establish a written fire safety management component of the protection plan that complies with this section for systematic achievement of the fire safety goals and objectives developed in compliance with Sections 4.2 and 4.3.

7.2.2 The fire safety management component of the protection plan shall comply with this section and shall provide for systematic achievement of fire safety goals and objectives developed in compliance with Sections 4.2 and 4.3.

7.2.3 The fire safety management component of the protection plan shall include provisions for an annual comprehensive facility inspection and procedures to document and correct problems and potential threats identified during the inspection. (See *Annexes I and J for additional information.*)

7.2.4 The fire safety management component of the protection plan shall be updated annually or when any addition, alteration, modification, or change in the occupancy occurs.

7.3* Fire Safety Manager.

7.3.1 The governing body shall appoint a fire safety manager who is responsible for implementation of the fire safety management component of the protection plan.

7.3.2 The fire safety manager shall be responsible for oversight of all of the following:

- (1) Egress systems
- (2) Fire prevention
- (3) Fire inspections
- (4) Periodic property surveys
- (5) Operation, maintenance, and testing of fire protection equipment, such as fire detection and fire suppression equipment
- (6) Management operational systems (see *Chapter 10*)

7.3.3* The fire safety manager shall monitor controls developed for fire hazards inherent to the cultural resource property.

7.3.4 The fire safety manager shall review and approve plans for new displays or exhibits, new construction, renovation, modification, restoration, or reconfiguration of space.

7.3.5 After any incident the fire safety manager shall review lessons learned from the incident with the planning team (see 5.3.2). The planning team shall make changes as appropriate to the fire safety management component of the protection plan and retrain staff on the changes as necessary.

7.4 Documentation.

7.4.1* The fire safety manager shall maintain a current file of the cultural resource property's fire protection records.

7.4.2 As a minimum, records of the following shall be kept:

- (1) The protection plan
- (2) Training of staff and volunteers, including fire evacuation drills, damage limitation, and use of portable fire extinguishers
- (3) Inspection, testing, and maintenance reports for all fire safety equipment and systems, including records of actions taken to correct deficiencies
- (4) As-built plans, specifications, wiring and layout diagrams, and acceptance test reports for all fire protection systems (e.g., fire detection and alarm systems, automatic fire suppression systems)
- (5) Inspection reports by local code enforcement officials, the authority having jurisdiction, local fire service officials, and insurance loss control representatives, including records of actions taken to correct deficiencies identified during each inspection
- (6) Fire protection systems actuation and alarm reports that include information on the cause of the alarm or activation, the response, and any corrective action(s) taken
- (7) Full reports of all fire incidents, including the cause, extent of damage, response, and recovery activities

7.5 Training.

7.5.1 The fire safety manager shall ensure that all staff, including volunteers and interns, receive initial and annual training pertinent to their assigned emergency responsibilities.

7.5.2 Training shall be reinforced by annual drills.

Chapter 8 Protection Plan — Security

8.1 Vulnerability Assessment.

8.1.1* A vulnerability assessment shall be conducted in accordance with 5.2.3 and Section 5.4 that examines all of the following:

- (1) Potential threats from crimes
- (2) Losses through the deliberate actions of third parties, staff, or visitors
- (3) Breaches in security caused by natural disasters
- (4) Other conditions or physical situations with the potential to cause damage or loss

8.1.2* The vulnerability assessment shall include, but shall not be limited to, all of the following:

- (1) Threats from conditions that increase the risk of arson
- (2) Threats posed by construction, alteration, renovation, or modification projects
- (3) Threat potential of terrorist activity

8.2* Security Component of Protection Plan.

8.2.1 A security component of the protection plan shall be prepared and adopted.

8.2.2 The security component shall be based on the results of an analysis of all of the following:

- (1) Potential threats identified in the vulnerability assessment
- (2) Loss tolerability threshold adopted by the governing body
- (3) Goals and objectives set for the cultural resource property

8.2.3* Arson prevention shall be included in the cultural resource property's protection goals and objectives developed in compliance with Sections 4.2 and 4.3.

8.2.4 The security component of the protection plan shall include screening all personnel, including part-time and volunteers, against records of known fire setters.

8.2.5* Book returns shall comply with one of the following:

- (1) They shall be constructed to prevent the spread of fire and smoke from the return into the rest of the library.
- (2) They shall be located in an outside receiving bin away from the exterior walls of the building.

8.2.6* The security component of the protection plan shall include protective measures for potential acts of terrorism.

8.2.7* The security component of the protection plan shall include procedures for all of the following:

- (1) Responding to unattended objects, containers, or packages
- (2) Responding to bomb threats
- (3) Handling suspicious parcels and letters
- (4) Responding to explosions and fires
- (5) Responding to chemical, biological, and radiological threats

8.3 Security Program.

8.3.1* Pre-Employment Screening. All employees and volunteers shall be subjected to pre-employment screening.

8.3.2* Access Control. Procedures shall be implemented to screen and identify official visitors, contractors, and others who have access to nonpublic areas of the cultural resource property.

8.3.3 Parcel Control. Procedures shall be implemented to control the flow of property in and out of the cultural resource property.

8.3.4 Electronic Premises Security Systems.

8.3.4.1* Where the vulnerability assessment indicates the need for an electronic premises security system, the system shall be designed by a qualified person.

8.3.4.2* Electronic premises security systems shall be installed in accordance with NFPA 731.

8.3.5* Physical Security Devices.

8.3.5.1 Installation and Maintenance. Where part of the protection plan, physical security devices, including but not limited to locks, doors, windows, safes, vaults, and strong rooms, shall be installed and maintained in accordance with the manufacturer's specifications.

8.3.5.2 Delayed Egress Locking Systems.

8.3.5.2.1 Approved, listed, delayed-egress locking systems shall be permitted to be installed on door assemblies serving low—and ordinary-hazard contents in buildings protected throughout by an approved, supervised automatic fire detection system in accordance with *NFPA 72* or an approved, supervised automatic sprinkler system in accordance with *NFPA 13* and where permitted in Chapters 11 through 43 of *NFPA 101*, provided that all of the following criteria are met:

- (1) The door leaves shall unlock in the direction of egress upon actuation of one of the following:
 - (a) Approved, supervised automatic sprinkler system in accordance with *NFPA 13*
 - (b) Not more than one heat detector of an approved, supervised automatic fire detection system in accordance with *NFPA 72*
 - (c) Not more than two smoke detectors of an approved, supervised automatic fire detection system in accordance with *NFPA 72*
- (2) The door leaves shall unlock in the direction of egress upon loss of power controlling the lock or locking mechanism.
- (3) An irreversible process shall release the lock in the direction of egress within 15 seconds, or 30 seconds where approved by the authority having jurisdiction, upon application of a force to the release device under all of the following conditions:
 - (a) The force shall not be required to exceed 67 N (15 lbf).
 - (b) The force shall not be required to be continuously applied for more than 3 seconds.
 - (c) The initiation of the release process shall activate an audible signal in the vicinity of the door opening.

- (d) Once the lock has been released by the application of force to the releasing device, relocking shall be by manual means only.
- (4) A readily visible, durable sign in letters not less than 25 mm (1 in.) high and not less than 3.2 mm ($\frac{1}{8}$ in.) in stroke width on a contrasting background that reads as follows shall be located on the door leaf adjacent to the release device in the direction of egress, and shall read as follows:
- (a) **PUSH UNTIL ALARM SOUNDS, DOOR CAN BE OPENED IN 15 SECONDS**, for doors that swing in the direction of egress travel
- (b) **PULL UNTIL ALARM SOUNDS, DOOR CAN BE OPENED IN 15 SECONDS**, for doors that swing against the direction of egress travel
- (5) The egress side of doors equipped with delayed-egress locks shall be provided with emergency lighting in accordance with Section 7.9 of NFPA 101.
- [101:7.2.1.6.1.1]

8.3.5.2.2 Delayed egress locking devices shall be tested regularly, but not less than quarterly, and a written record of the test and the results shall be kept.

8.3.5.3 Access-Controlled Egress Door Assemblies. Where provided, access-controlled egress door assemblies shall comply with NFPA 101.

8.4 Construction Areas. Security precautions for construction areas shall be in accordance with 9.14.11.

8.5* Vacant Areas. Structures or portions thereof that are vacant shall be included in the vulnerability assessment required by Section 8.1.

Chapter 9 New Construction, Addition, Alteration, Renovation, and Modification Projects

9.1* General. New construction, additions, alterations, renovations, and modifications, hereafter referred to as the project, shall comply with the applicable building code and the requirements of this chapter.

9.2* Application of Code. This code shall be applied to projects in accordance with the process described in Figure 9.2.

9.3* Project Team. The governing body shall identify a project team to oversee the application of the code to the cultural resource property.

9.3.1 The project team shall include persons with expertise in cultural resource property preservation and protection.

9.3.2 Persons named to the team to comply with 9.3.1 shall have a demonstrated knowledge and understanding of the culturally significant elements of the structure and its contents.

9.4* Survey. The project team shall conduct a detailed survey including but not limited to the following:

- (1) Operating and protection features of the protection plan
- (2) Culturally significant features of the structure and collections impacted by the project

9.4.1 Structure.

9.4.1.1* Exterior. The survey shall identify those character-defining features and finishes that make the exterior of the building significant.

9.4.1.2* Interior. The survey shall identify all significant interior spaces, floor plan organization, and character-defining features and finishes in the building.

9.4.2 Collections. The survey shall identify all significant collections, archives, and other contents of cultural significance, their location, and any unique vulnerability to damage or loss.

9.5 Operations. The project team shall identify the facility's client community and the effect of a disruption of operations on the delivery of service to that community.

9.6 Prioritization of Significant Elements, Collections, and Operations.

9.6.1 The project team shall determine primary and secondary significance of all culturally significant elements, collections, or both, and the primary and secondary operational priorities for the facility.

9.6.2* Planned modifications or additions shall be assessed to determine their impact on culturally significant elements, collections, and the operation.

9.7 Potential Threat Identification and Evaluation.

9.7.1 The project team shall identify conditions that could contribute to the loss of property, including but not limited to the structure, site, and collections, by fire; foreseeable crimes; deliberate acts of third parties, staff, or visitors; or other events with the potential to cause damage or loss in the areas affected by the project.

9.7.1.1 The project team shall review all fire safety and security related requirements to determine if and where the cultural resource property is deficient with respect to applicable codes.

9.7.1.2 The project team shall evaluate the building to determine the potential paths of fire spread, both internal and external, that are inherent to its design.

9.7.2 Means of Egress.

9.7.2.1 The project team shall evaluate life safety aspects of the building in accordance with the requirements of the applicable building or life safety code.

9.7.2.2 The project team shall identify egress systems and any deficiencies, including, but not limited to, number of exits, exit capacity, exit fire resistance, smoke control, dead-end corridors, travel distances, and unenclosed stairs and shall develop plans to mitigate the deficiencies.

9.7.3 The project team shall evaluate the tolerability of the potential threats identified in 9.8.1 based on the cultural resource property's protection goals and objectives developed in compliance with Sections 4.2 and 4.3 and the tolerability thresholds developed in compliance with 5.2.5.

9.8 Vulnerability Assessment and Evaluation.

9.8.1 The project team shall evaluate the potential consequences and estimate the frequency of damage or losses from all potential threats identified in 9.7.3 as unacceptable using methods described in Section 5.3.

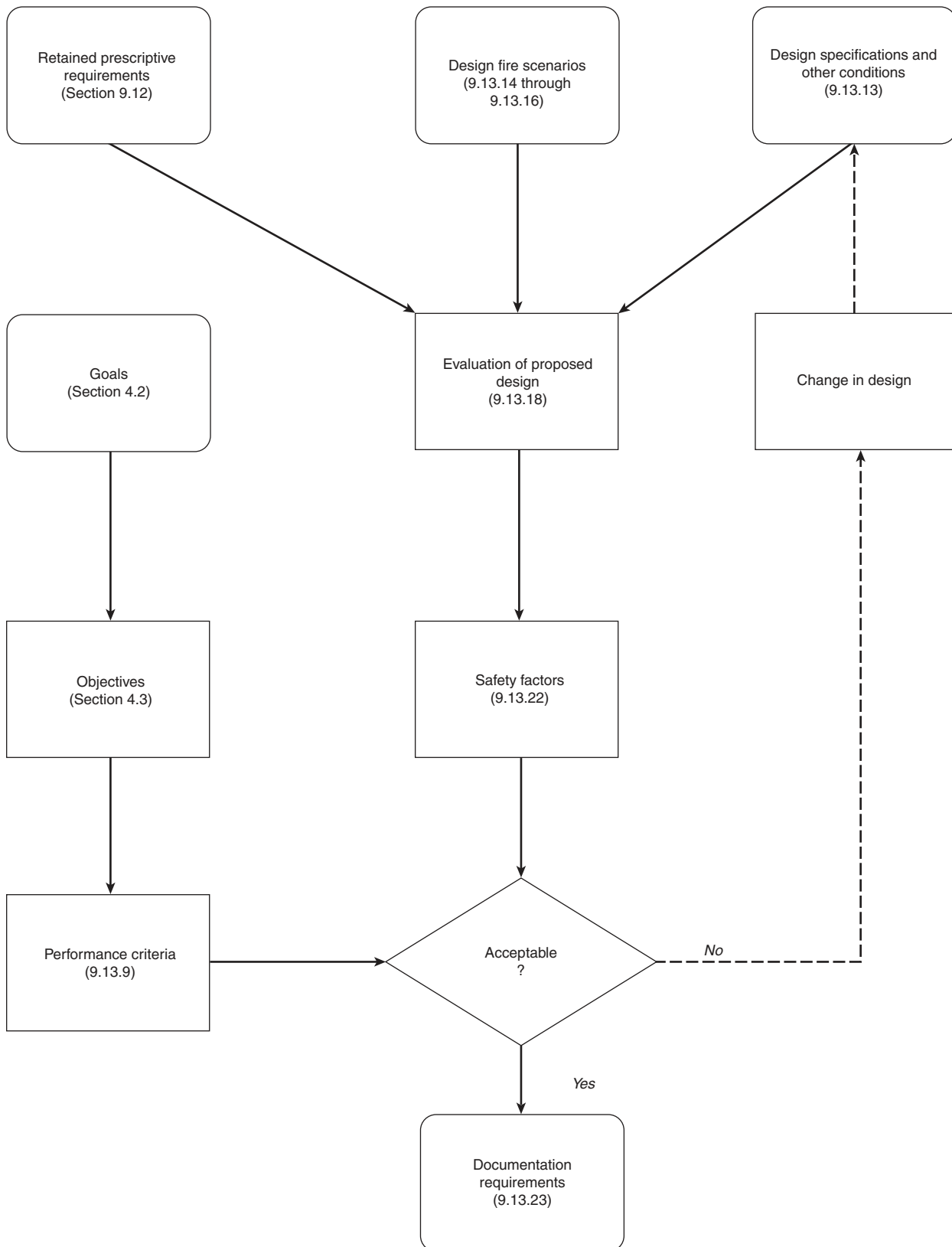

FIGURE 9.2 Code Application Process.

9.8.2 The project team shall determine risk tolerability by comparing the risk from the potential threats identified in 9.7.3 with the goals and objectives developed in compliance with Sections 4.2 and 4.3 and the tolerability thresholds developed in compliance with 5.2.5.

9.9 Plans and Designs.

9.9.1 The project team shall develop plans and designs to eliminate, manage, or control risks identified as intolerable in 9.8.2.

9.9.2 The project team shall evaluate planned modifications or additions to determine their impact on culturally significant elements, collections, and the operation.

9.9.3 Alternative methods that offer equivalent or greater protection while preserving the character-defining spaces, features, finishes, and collections of the cultural resource property shall be permitted.

9.9.4 The project team shall identify any impact the project might have on the existing protection plan and notify those responsible for updating or changing it.

9.10 Options.

9.10.1 Projects that satisfy the objectives developed in compliance with Section 4.3 shall be subject to the compliance audit required by 9.13.39.

9.10.2 Where projects that do not satisfy the objectives developed in compliance with Section 4.3 or that have protection deficiencies, the project team shall develop a corrective action plan that satisfies one of the following:

- (1) Prescriptive compliance, including equivalencies, alternatives, and modifications
- (2) Performance-based compliance
- (3) Any combination of items 9.10.2(1) and 9.10.2(2)

9.10.3 Option Evaluation and Selection.

9.10.3.1* Selection Criteria.

9.10.3.2 The project team shall evaluate the available options and select a method for applying the code.

9.10.3.3 Prescriptive solutions shall meet requirements of Chapters 1 through 8, Sections 9.1 through 9.12, Section 9.14, and Chapters 10 through 15 of this code, including any exceptions contained within the referenced prescriptive codes and standards.

9.10.3.4 Performance-based solutions shall be developed in accordance with Chapters 1 through 8, Sections 9.1 through 9.11, and Section 9.13 of this code.

9.11 Design Review. The project team shall review and approve the preferred design approach for achieving compliance.

9.12* Prescriptive-Based Option.

9.12.1 Prescriptive requirements of the applicable codes shall be applied with the intent of achieving the goals and objectives developed in compliance with Sections 4.2 and 4.3.

9.12.2 Application of prescriptive requirements shall include alternatives, equivalencies, modifications, or any combination thereof.

9.12.3* Alternatives. Prescribed alternative methods of compliance with the applicable code shall be identified.

9.12.4* Equivalency.

9.12.4.1 The authority having jurisdiction shall approve other fire safety approaches, systems, methods, or devices that are equivalent or superior to those prescribed by this code, provided adequate documentation is submitted to demonstrate equivalency.

9.12.4.2* Approaches, systems, methods, or devices approved as equivalent by the authority having jurisdiction shall be recognized as being in compliance with this code.

9.12.5* Modifications of Requirements.

9.12.5.1 The requirements of the applicable codes shall be permitted to be modified if their application clearly would be impractical in the judgment of the authority having jurisdiction, but only where it is also clearly evident that a reasonable degree of safety is provided.

9.12.5.2 The modifications allowed, and any additional requirements imposed as a result, shall be documented in the protection plan.

9.12.6* Compensatory Features. Where equivalencies of modifications to existing requirements are proposed, the following fire safety features shall be considered as compensatory:

- (1) Noncombustible or limited-combustible construction materials
- (2) Noncombustible or fire-retardant treated interior finish materials
- (3) Noncombustible or fire-retardant treated materials for furnishings and contents
- (4) Rated walls and doors that prevent the horizontal spread of fire and smoke, to subdivide building areas or to segregate specific hazards, such as boilers, furnaces, or storage areas, from the remainder of the building
- (5) Enclosure of stairways, ventilation shafts, and other vertical openings with rated construction to prevent the vertical spread of fire and smoke
- (6)* Firestops and fireblocks to prevent the spread of fire within walls, between rafters and joists, and through horizontal and vertical fire barriers
- (7)* Fire-resistive construction using fire-resistive materials
- (8)* Fire detection and alarm systems that sound an alarm within the structure and that transmit an alarm signal to an alarm-monitoring location or to a local fire department
- (9) Automatic suppression system, manual suppression systems, or a combination of both
- (10) Management and operational controls that meet the requirements of Chapter 10
- (11) Installation of arc-fault circuit-interrupters (AFCIs)
- (12) Height of ceilings, with recognition that a large volume of space above head height provides occupants at floor level additional time to evacuate the room or building

9.12.7 Materials.**9.12.7.1 Noncombustible Material.**

9.12.7.1.1* A material that complies with any one of the following shall be considered a noncombustible material:

- (1)* The material, in the form in which it is used and under the conditions anticipated, will not ignite, burn, support combustion, or release flammable vapors, when subjected to fire or heat
- (2) The material is reported as passing ASTM E136, *Standard Test Method for Behavior of Materials in a Vertical Tube Furnace at 750 Degrees C*
- (3) The material is reported as complying with the pass/fail criteria of ASTM E136 when tested in accordance with the test method and procedure in ASTM E2652, *Standard Test Method for Behavior of Materials in a Tube Furnace with a Cone-shaped Airflow Stabilizer, at 750 Degrees C*.

[5000:7.1.4.1.1]

9.12.7.1.2 Where the term *limited-combustible* is used in this code, it shall also include the term *noncombustible*.

[5000:7.1.4.1.2]

9.12.7.2 Limited-Combustible Material. A material shall be considered a limited combustible material where all the conditions of 9.12.7.2(1) and 9.12.7.2(2), and the conditions of either 9.12.7.2.1 or 9.12.7.2.2 are met: [5000:7.1.4.2]

- (1) The material does not comply with the requirements for a noncombustible material, in accordance with 9.12.7.1. [5000:7.1.4.2(1)]
- (2) The material, in the form in which it is used, exhibits a potential heat value not exceeding 3500 Btu/lb (8141 kJ/kg), when tested in accordance with NFPA 259. [5000:7.1.4.2(2)]

9.12.7.2.1 The material shall have the structural base of a noncombustible material with a surfacing not exceeding a thickness of $\frac{1}{8}$ in. (3.2 mm) where the surfacing exhibits a flame spread index not greater than 50 when tested in accordance with ASTM E84, *Standard Test Method for Surface Burning Characteristics of Building Materials*, or ANSI/UL 723, *Standard for Test for Surface Burning Characteristics of Building Materials*. [5000:7.1.4.2.1]

9.12.7.2.2 The material shall be composed of materials that, in the form and thickness used, neither exhibit a flame spread index greater than 25 nor evidence of continued progressive combustion when tested in accordance with ASTM E84 or ANSI/UL 723, and are of such composition that all surfaces that would be exposed by cutting through the material on any plane would neither exhibit a flame spread index greater than 25 nor exhibit evidence of continued progressive combustion when tested in accordance with ASTM E84 or ANSI/UL 723. [5000:7.1.4.2.2]

9.12.7.2.3 Where the term *limited-combustible* is used in this code, it shall also include the term *noncombustible*. [5000:7.1.4.2.3]

9.12.8 Fire Spread Control.

9.12.8.1 New openings in fire-rated assemblies, such as for doorways and pipe and duct penetrations, shall have self-closing or automatic fire doors and automatic fire dampers having fire resistance ratings in accordance with the applicable building code.

9.12.8.2 Actuation of any automatic fire protection system in a fire area shall close all automatic fire dampers in the fire areas served by the system.

9.12.8.3 Penetrations in fire-rated assemblies around wiring, pipes, ducts, and so forth, shall be sealed with approved materials to maintain the integrity of the fire-rated assembly.

9.12.8.4 New elevator shafts, dumbwaiters, stairways, and other vertical openings through the structure shall be constructed in a manner to prevent the spread of fire, smoke, and heat from one level to another.

9.12.8.5 New doors in fire-rated assemblies that are required to remain in the open position for any reason shall be equipped with approved door-holding devices controlled by a listed device or system.

9.12.9* Protection Systems.

9.12.9.1 Existing Protection Systems. The project team shall evaluate the design and layout of existing electronic premises security, fire detection, and fire suppression systems for impairments caused by the project work.

9.12.9.2 New Construction. New construction shall include all of the following features:

- (1) Fire detection systems as required by applicable codes
- (2) Automatic fire sprinkler systems or alternative suppression systems
- (3) Electronic premises security systems as required in the protection plan

9.12.10* Fire Detection and Alarm Systems. Fire detection and alarm systems shall comply with the requirements of *NFPA 72*.

9.12.10.1 Where a fire detection system is required, smoke detectors shall be installed where ambient conditions permit.

9.12.10.2 Where ambient conditions will adversely affect the performance, reliability, or normal operation of smoke detectors, other forms of detection technology, such as heat detection, shall be used.

9.12.11 Electronic Premises Security Systems. Electronic premises security systems shall comply with the requirements of *NFPA 731*.

9.12.12 Alarm Monitoring.

9.12.12.1 Automatic fire suppression systems shall be monitored for water flow and tamper by a fire alarm system complying with *NFPA 72*.

9.12.12.2 Fire detection and alarm systems shall transmit alarm, supervisory, and trouble signals to an approved supervising station.

9.12.12.3 The supervising station and the communications methods used for fire alarm signal transmission shall comply with the requirements of *NFPA 72*.

9.12.12.4 Electronic premises security systems shall transmit alarm, trouble, and environmental signals to an approved monitoring station.

9.12.12.5 The monitoring station and the communications methods used for signal transmission shall comply with the requirements of *NFPA 731*.

9.12.13* Automatic Fire Sprinkler Systems.

9.12.13.1 Automatic fire sprinkler systems shall comply with the requirements of NFPA 13.

9.12.13.2* Standard response sprinklers shall be permitted for use in light hazard areas.

9.12.13.3* Corrosion Protection. Preaction and dry pipe systems shall be designed to minimize the risk of corrosion in accordance with the requirements of 9.12.13.3.1 through 9.12.13.3.6.5.

9.12.13.3.1* Branch lines shall be pitched at least 4 mm/m ($\frac{1}{2}$ in. per 10 ft), and mains shall be pitched at least 2 mm/m ($\frac{1}{4}$ in. per 10 ft).

9.12.13.3.2 Auxiliary drains shall be provided at all dry system low points in accordance with NFPA 13.

9.12.13.3.2.1* Auxiliary drains shall be provided at all preaction system low points in accordance with the requirements for dry pipe systems whether the preaction system piping subject to freezing or not.

9.12.13.3.2.2 Auxiliary drains shall be operated in accordance with the requirements of NFPA 25.

9.12.13.3.3* Where steel pipe is used in dry pipe and preaction systems, it shall be assumed that the water supplies and environmental conditions contribute to unusual corrosive properties.

9.12.13.3.4 A corrosion protection plan shall be developed to address piping corrosion in accordance with NFPA 13.

9.12.13.3.5 Sprinkler piping and fittings shall be inspected annually for signs of corrosion, leakage, and physical damage, in accordance with NFPA 25.

9.12.13.3.6* An internal corrosion evaluation of system piping shall be conducted at intervals not to exceed 5 years.

9.12.13.3.6.1 The evaluation shall include an internal inspection of the piping condition near the sprinkler riser and the opening of the flushing connection on a system main.

9.12.13.3.6.2 Alternative nondestructive examination methods shall be permitted.

9.12.13.3.6.3 Where the inspection or examinations required by 9.12.13.3.6.1 or 9.12.13.3.6.3 reveal that pitting, nodules, tubercles, or carbuncles are present, an obstruction investigation shall be conducted in accordance with the requirements of NFPA 25.

9.12.13.3.6.4 Repairs shall be made as necessary.

9.12.13.3.6.5 Nonmetallic pipe shall not be required to be inspected internally.

9.12.13.4 CPVC Pipe.

9.12.13.4.1* CPVC pipe shall be stored and handled in accordance with the manufacturer's installation instructions and the applicable requirements of NFPA 13.

9.12.13.4.2* CPVC pipe shall be installed in accordance with the manufacturer's installation instructions.

9.12.13.4.3* The governing body of the cultural resource property shall develop plans and procedures to ensure CPVC

pipe is not exposed to physical damage or incompatible materials over the life of the sprinkler system.

9.12.14 Alternative Fire Suppression Systems. Where other types of fire suppression systems are provided, they shall comply with the applicable standard referenced in Table 9.12.14.

9.12.15* Standpipe and Hose Systems. Standpipe and hose systems, where required, shall comply with the requirements of NFPA 14.

9.12.16* Portable Fire Extinguishers. Portable fire extinguishers shall be selected, installed, and maintained in compliance with the provisions of NFPA 10.

9.12.17* Testing of Integrated Systems. Integrated fire protection and life safety systems shall be tested in accordance with NFPA 4.

9.12.18 Roof Coverings.

9.12.18.1 Unlisted combustible roof coverings shall be treated with an approved fire-retardant coating.

9.12.18.2 The facility shall maintain a record of the treatment, including certificates of approval of retardant, application method, and retreatment schedule.

9.12.18.3 Fire-retardant coated roof coverings shall be retreated in accordance with the manufacturer's specifications.

9.12.19 Emergency Power.

9.12.19.1* Emergency generators, where required, shall comply with the requirements of NFPA 110.

9.12.19.2 Emergency generators shall have sufficient capacity to support critical fire safety functions and fire suppression systems, where required.

9.12.19.3* Emergency generators that support other functions considered essential shall have sufficient capacity to support all functions with no degradation of fire safety system support.

9.12.20* Hazardous Areas. Hazardous areas shall be separated from other areas by a fire separation rated for a minimum of 1-hour fire resistance rating.

Table 9.12.14 Fire Suppression System Installation Standards

Fire Suppression System Type	NFPA Standard
Low-, medium-, and high-expansion foam systems	NFPA 11
Carbon dioxide systems	NFPA 12
Halon 1301 systems	NFPA 12A
Water spray fixed systems	NFPA 15
Deluge foam-water sprinkler systems	NFPA 16
Dry chemical systems	NFPA 17
Wet chemical systems	NFPA 17A
Water mist systems	NFPA 750
Clean agent extinguishing systems	NFPA 2001
Aerosol extinguishing systems	NFPA 2010

9.12.21 Interior Finishes. Interior finish materials shall comply with the requirements of the applicable building code, except that the use of textile wall coverings and textile ceiling coverings shall comply with 9.12.21.1, 9.12.21.2, or 9.12.21.3.

9.12.21.1 Textile wall coverings and textile ceiling coverings tested in accordance with ASTM E84 or ANSI/UL 723, having a flame spread index of 0 through 25 and a smoke developed index of 0 through 450, shall be permitted where one of the following conditions is met:

- (1) Rooms or areas are protected by an approved automatic sprinkler system.
- (2) Partitions do not exceed three-quarters of the floor-to-ceiling height or do not exceed 2330 mm (8 ft) in height, whichever is less.
- (3) Textile wall coverings extend not more than 1220 mm (48 in.) above the finished floor on ceiling-height walls and ceiling-height partitions.

9.12.21.2 Textile wall coverings tested using method B of the test protocol of NFPA 265 shall be permitted where all of the following conditions are met:

- (1) Flame shall not spread to the ceiling during the 40 kW
- (2) During the 150 kW exposure, the following criteria shall be met:
 - (a) Flame shall not spread to the outer extremities of the sample on the 2440 mm × 3660 mm (8 ft × 12 ft) wall.
 - (b) Flashover shall not occur.

9.12.21.3 Textile wall coverings and textile ceiling coverings tested in accordance with NFPA 286 shall be permitted where all the following conditions are met:

- (1) Flames shall not spread to the ceiling during the 40 kW exposure.
- (2) During the 160 kW exposure, the following criteria shall be met:
 - (a) Flame shall not spread to the outer extremities of the sample on the 2440 mm × 3660 mm (8 ft × 12 ft) wall.
 - (b) Flashover shall not occur.
- (3) The peak heat release rate throughout the test shall not exceed 800 kW.
- (4) For new installations, the total smoke released throughout the test shall not exceed 1000 m² (10,760 ft²).

9.12.22* Lightning Protection. A lightning protection system, where required, shall be designed, installed, and maintained in accordance with NFPA 780.

9.12.23 Location. A cultural resource property located within or attached to a building or structure classified as industrial or storage or containing high-hazard contents as classified by the applicable building code shall be separated from the other use area by walls or partitions and floor or floor-ceiling assemblies having a fire resistance rating in accordance with the applicable building code.

9.12.24 Collection Storage Rooms. This section shall apply to building areas used for collection storage rooms.

9.12.24.1 Construction.

9.12.24.1.1 Collection storage rooms shall be enclosed by fire barriers having a minimum 1-hour fire resistance rating.

9.12.24.1.2 Collection storage rooms adjoining incinerator rooms, furnace and boiler rooms, paint shops, and other spaces having a significant fire hazard shall be separated from such spaces by a fire barrier having a 2-hour fire resistance rating.

9.12.24.2 Emergency Lighting. Emergency lighting shall be provided for safe egress and shall comply with the requirements of the applicable building code, fire code, or life safety code.

9.12.24.3 Fire Protection.

9.12.24.3.1 Collection storage rooms shall be provided with all of the following fire alarm system components:

- (1) Notification appliances
- (2) Manual fire alarm boxes
- (3) Automatic smoke detection

9.12.24.3.2* An approved automatic fire suppression system shall be provided in collection storage rooms greater than 46.25 m² (500 ft²) unless the space contains only noncombustible collections including packing or crating materials, cabinets, and shelves or where all collections are stored inside approved noncombustible cabinets.

9.12.24.4* Compact Storage.

9.12.24.4.1 Fire Suppression System.

9.12.24.4.1.1 An automatic fire suppression system shall be required for compact storage of collections.

9.12.24.4.1.2 Where the compact storage system consists entirely of enclosed noncombustible cabinets and no collections or other combustibles are stored outside of the enclosed cabinets, automatic fire suppression shall be permitted to be omitted subject to the approval of the authority having jurisdiction.

9.12.24.4.1.3* The design shall recognize the nature of the potential threat of a fire that originates in a compact mobile storage unit, where fuel loads are invariably large and fire growth is significantly different from that in other kinds of storage.

9.12.24.4.1.4 System Design.

(A)* The automatic fire suppression system, the compact storage system, and the storage compartmentalization features shall be designed to limit fire damage in accordance with the facility's fire safety objectives.

(B) Design calculations shall include the number and size of the storage modules, the separation provided between the modules end-to-end and back-to-back, and type of material being stored.

(C) Where the automatic fire suppression is provided by automatic fire sprinkler systems, the systems shall be wet pipe, single interlock preaction, or non-interlock preaction systems.

(D) Dry pipe or double-interlock preaction systems shall not be installed in compact storage areas.

(E) Where compact storage is installed in an existing storage area, the existing automatic fire detection and fire suppression systems shall be modified as required to accommodate the increased fire loading.

9.12.24.5 Utilities.

9.12.24.5.1 Utilities other than those supporting fire suppression, fire detection, and security systems, or that directly serve the space, shall not pass through collection storage rooms.

9.12.24.5.2 Controls for utilities that serve the collection storage room shall be located outside the space so that access to the controls does not require entry into the collections storage rooms.

9.12.24.5.3 Controls for utilities that serve collection storage rooms shall be designed to allow isolation of storage space utilities in an emergency.

9.12.24.5.4 Electrical distribution power panels shall not be installed in collection storage rooms.

9.12.24.6* Smoke Control. Approved systems shall be provided to prevent smoke and soot from entering collection storage rooms.

9.12.24.7 Wet Collections. Shelving units used to hold wet collections shall meet the following requirements:

- (1) Designed to support the loads placed on them
- (2) Tied together or anchored securely to prevent an earthquake or other event from toppling one or more shelves
- (3) Constructed with raised lips and barriers across all open shelves to prevent containers from falling off the shelf
- (4) Anchored and braced in storage areas that are subject to earthquakes
- (5)* Designed such that anchors and bracing provide shelving with strength equal to or greater than the building structure

9.12.24.8* Book Stacks.

9.12.24.8.1 The fire load within a fire compartment containing a multi-tier book stack shall be determined by combining the fuel loading of all levels or tiers in the multi-tier book stack enclosed by the fire compartment.

9.12.24.8.2 An automatic fire detection system designed and installed in compliance with *NFPA 72* shall be installed in single-tier book stacks.

9.12.24.8.3 An automatic fire suppression system designed and installed in compliance with *NFPA 13* shall be installed in the book stacks.

9.12.24.8.4 Smoke barriers shall be installed in all vertical openings between tiers or decks of multi-tier book stacks.

9.12.24.9 Security.

9.12.24.9.1 Collections storage areas shall be equipped with burglary-resistant locks.

9.12.24.9.1.1 Keyed locks shall have a strike bolt into a solid frame.

9.12.24.9.1.2 Strike plates shall be fastened through the frame and into the structure.

9.12.24.9.2 Doors shall be of a solid-core design or steel construction.

9.12.24.9.2.1 Hinges shall be on the secure side of the door.

9.12.24.9.2.2 When the door must swing out, the hinges shall be protected using nonremovable hinge pins or hinges that incorporate security studs.

9.12.24.9.2.3 Door frames shall be fastened to the wall studs.

9.12.24.9.3 Where collections storage rooms are equipped with intrusion alarms, the alarms shall be installed in accordance with *NFPA 731*.

9.12.24.10 Secondary Storage Facilities. Secondary storage facilities greater than 46.25 m² (500 ft²) shall be protected by automatic fire sprinklers installed in compliance with *NFPA 13*.

9.12.24.10.1 Vertical Shelf Barriers. Shelving shall be provided with full height solid vertical transverse barriers of 9.5 mm ($\frac{3}{8}$ in.) plywood or particleboard, 22 ga. sheet metal, or equivalent, from face of aisle to face of aisle, spaced at intervals not exceeding 13.7 m (45 ft).

9.12.24.10.2 Powered Industrial Trucks. Use, maintenance, and operation of powered industrial trucks shall comply with *NFPA 505*.

9.12.25* Exhibit Design and Construction.

9.12.25.1 Protection Plan.

9.12.25.1.1 The fire safety manager shall review exhibit installation plans to ensure compliance with the protection plan.

9.12.25.1.2 The proposed exhibit shall not compromise or adversely affect the following in the exhibit, the exhibition area, or the building:

- (1) Egress systems, equipment, and measures
- (2) Emergency access
- (3) Fire protection systems, including detection, alarms, and automatic suppression
- (4) Fire safety
- (5) Emergency lighting systems

9.12.25.1.3 Special lighting effects in the exhibit and exhibition area shall not reduce illumination below the minimum level specified by the applicable building code, fire code, or life safety code for egress.

9.12.25.1.4 Special lighting effects shall not create a fire hazard.

9.12.25.1.5 The fire safety manager shall be informed and involved at every stage including preliminary planning, design, fabrication, and installation for each exhibit mounted or installed.

9.12.25.2 Exhibit Cases.

9.12.25.2.1 Fixed exhibit cases that are integral with the building structure in fully protected buildings or where fire suppression systems are required by the applicable building code shall be equipped with approved fire detection and suppression systems.

9.12.25.2.1.1* Fixed or movable exhibit cases that are not integral with the building structure in fully protected buildings or where fire suppression systems are required by the applicable building code shall be equipped with approved fire detection systems.

9.12.25.2.1.2 Fire suppression systems shall be permitted to be deleted when the exhibit cases have all of the following:

- (1) No internal ignition sources
- (2) Full enclosure with complete sides, top, and bottom that are not integral with the building structure
- (3) Do not communicate directly with the primary HVAC system or with void spaces in the walls, floor, or ceiling
- (4) Fixed cases constructed of metal, glass, or other noncombustible material
- (5) The areas around the exhibit cases protected by an automatic fire suppression system

9.12.25.2.2* Light fixtures, motors, active climate control systems, or other electrical or mechanical components installed in exhibit cases shall be located outside the artifact chamber.

9.12.25.2.3* Where flammable or highly combustible materials are displayed in exhibit cases, whether movable or fixed, the cases or the areas in which they are located shall be protected by approved fire detection and fire suppression systems.

9.12.25.3 Exhibit Materials.

9.12.25.3.1* Exhibits shall be fabricated and constructed using materials that are either noncombustible or fire retardant treated.

9.12.25.3.2* When the fire-retardant treatment may harm a collection object, exhibit construction or backing materials shall not be fire retardant treated when all of the following are true:

- (1) The fire retardant material is close enough to the collection object to have the capacity to harm.
- (2) The distance for capacity to harm is calculated for each collection object in the case.
- (3) Fire-retardant treatment is only omitted where it has the capacity to harm a collection object.

9.12.25.3.3 Exhibit construction or backing materials treated with a chemical fire retardant shall be retreated at intervals in accordance with the manufacturer's specifications.

9.12.25.4 Electrical Requirements.

9.12.25.4.1 Electrical wiring and work installed for an exhibit shall comply with the provisions of *NFPA 70*.

9.12.25.4.2* Arc-fault circuit-interrupters (AFCIs) shall be required in new exhibit construction.

9.12.25.5 Fire Protection.

9.12.25.5.1* Temporary walls and exhibit components shall not interfere with the following:

- (1) Coverage for fire alarm notification appliances
- (2) Operation of fire alarm manual station or automatic detection device
- (3) Spacing and location of automatic fire sprinklers
- (4) Operation of other automatic fire suppression system

9.12.25.5.2 Where interference with a fire protection system cannot be avoided, the system shall be modified to comply with the requirements of the applicable installation standard.

9.12.25.5.3 Display areas shall be evaluated for change in classification of occupancy and commodity as required by NFPA 13.

9.12.25.5.4 When there is a change in classification of occupancy or commodity, automatic fire suppression systems shall be redesigned or modified to protect the new classification.

9.12.26 Hazardous Areas.

9.12.26.1 General. Hazardous areas shall comply with both of the following:

- (1) Be separated from other areas by a minimum of 1-hour fire-rated construction
- (2) Be protected by an automatic fire suppression system

9.12.26.2* Painting. Paint spraying and spray booths shall comply with NFPA 33.

9.12.26.3* Laboratories. Laboratories shall comply with NFPA 45.

9.12.26.3.1 Laboratories shall be protected by an automatic fire suppression system.

9.12.26.3.2 Where required, explosionproof or intrinsically safe-type lighting fixtures, motors, and switches shall be installed in compliance with *NFPA 70*.

9.12.27 Public Areas.

9.12.27.1 Tiered structures and other elevated platforms on which people are permitted to sit shall be of noncombustible construction.

9.13* Performance-Based Option.

9.13.1 Application. The requirements of this section shall apply to protection systems and life safety systems designed using the performance-based option permitted by 9.10.3.

9.13.2 Goals and Objectives. The performance-based design shall meet the goals and objectives of this code identified in Sections 4.2 and 4.3.

9.13.3* Approved Qualifications. The performance-based design shall be prepared by a person with qualifications acceptable to the authority having jurisdiction.

9.13.4* Independent Review. The authority having jurisdiction shall be permitted to require review and evaluation of the proposed design by an approved, independent third party.

9.13.5 Sources of Data.

9.13.5.1 The source for each input data requirement that must be met using a data source other than a design fire scenario, an assumption, or a building design specification shall be identified and documented.

9.13.5.2 Such data shall be characterized as to the degree of conservatism reflected, and a justification for the source shall be provided.

9.13.6 Final Determination. The authority having jurisdiction shall make the final determination as to whether the performance objectives have been met.

9.13.7* Maintenance of Design Features.

9.13.7.1 Design features and management programs required for the building to continue to meet the performance goals and objectives of this code shall be maintained for the life of the building.

9.13.7.2 This management program shall include compliance with all documented assumptions and design specifications.

9.13.7.3 Any variations to the management program shall require the approval of the authority having jurisdiction prior to the actual change.

9.13.8 Special Definitions. The following is a list of special terms used in this chapter:

- (1) Design fire scenario (*See 3.3.74.1.*)
- (2) Design team (*See 3.3.20.*)
- (3) Exposure fire (*See 3.3.22.*)
- (4) Fire model (*See 3.3.26.*)
- (5) Fire scenario (*See 3.3.74.2.*)
- (6) Fuel load (*See 3.3.33.*)
- (7) Input data specification (*See 3.3.44.*)
- (8) Occupant characteristics (*See 3.3.55.*)
- (9) Performance criteria (*See 3.3.58.*)
- (10) Proposed design (*See 3.3.64.*)
- (11) Safety factor (*See 3.3.72.*)
- (12) Safety margin (*See 3.3.73.*)
- (13) Sensitivity analysis (*See 3.3.3.1.*)
- (14) Stakeholder (*See 3.3.81.*)
- (15) Uncertainty analysis (*See 3.3.3.2.*)
- (16) Verification method (*See 3.3.85.*)

9.13.9 Performance Criteria.

9.13.9.1 A cultural resource property shall meet the performance criteria for cultural resource property and collection conservation and continuity of operations.

9.13.9.2 Each design shall meet the objectives specified in Section 4.3 if, for each design fire scenario, assumption, and design specification, the performance criteria in 9.13.10 through 9.13.12 are met.

9.13.10 Collections Preservation Performance Criteria. No items of cultural value other than those intimate with the initiating event shall be exposed to instantaneous or cumulative untenable conditions.

9.13.11* Cultural Resource Property Preservation Criteria. Culturally significant features, rooms, spaces, or contents shall not be exposed to instantaneous or cumulative fire effects that would cause irreversible damage.

9.13.12 Continuity of Operations Criteria. The cultural institution shall not experience a disruption of routine operations greater than the risk tolerability thresholds developed in compliance with 5.2.5.

9.13.13 Design Specifications and Other Conditions.

9.13.13.1* Design specifications and other conditions used in the performance-based design shall be demonstrated to the authority having jurisdiction to be realistic and sustainable.

9.13.13.2 Assumptions and Design Specifications Data.

9.13.13.2.1 Each assumption and design specification used in the design shall be accurately translated into input data specifications, as appropriate for the calculation method or model.

9.13.13.2.2 Any assumptions and design specifications that the design analyses do not explicitly address or incorporate and that are therefore omitted from input data specifications shall be identified, and a sensitivity analysis of the consequences of that omission shall be performed.

9.13.13.2.3 Any assumptions and design specifications modified in input data specifications because of limitations in test methods or other data generation procedures shall be identified, and sensitivity analysis of the consequences of the modification shall be performed.

9.13.13.3* Building Characteristics. Characteristics of the building or its contents, equipment, or operations not inherent in the design specifications but that affect occupant behavior or the rate of hazard development shall be explicitly identified.

9.13.13.4* Operational Status and Effectiveness of Building Features and Systems. The performance of protection systems and building features shall reflect the documented performance of components of those systems or features unless design specifications are incorporated to modify the expected performance.

9.13.13.5 Occupant Characteristics.

9.13.13.5.1* General. The selection of occupant characteristics to be used in the design calculations shall be approved by the authority having jurisdiction and shall provide an accurate reflection of the expected population of building users.

9.13.13.5.2 Occupant characteristics shall represent the normal occupant profile unless design specifications are used to modify the expected occupant features.

9.13.13.5.3 Occupant characteristics shall not vary between design scenarios except as authorized by the authority having jurisdiction.

9.13.13.5.4* Response Characteristics. Each of the following basic performance characteristics shall be considered:

- (1) Sensibility
- (2) Reactivity
- (3) Mobility
- (4) Susceptibility

9.13.13.5.4.1 Estimations of these characteristics shall reflect the expected distribution in a population appropriate to the use of the building.

9.13.13.5.4.2 The source of the data for these characteristics shall be documented.

9.13.13.5.5 Location. The assumption shall be made that in every normally occupied room or area at least one person will be located at the most remote point from the exit.

9.13.13.5.6* Occupant Load.

9.13.13.5.6.1 The design shall be based on the maximum number of people that every occupied room or area is expected to contain.

9.13.13.5.6.2 Where success or failure of the design is contingent on a maximum number of occupants, operational controls shall be used.

9.13.13.5.7* Staff Assistance. The ability of trained employees to be included, as part of the protection system, shall be identified, and the necessary training and capabilities documented.

9.13.13.6 Emergency Response Personnel. Design characteristics or other conditions related to the availability, speed of response, effectiveness, roles, and other characteristics of emer-

gency response personnel shall be specified, estimated, or characterized sufficiently for evaluation of the design.

9.13.13.7* Post-Construction Conditions. Design characteristics or other conditions related to activities during the life of the building that affect the ability of the building to meet the stated goals and objectives shall be specified, estimated, or characterized sufficiently for evaluation of the design.

9.13.13.8 Off-Site Conditions. Design characteristics or other conditions related to resources or conditions outside the property being designated that affect the ability of the building to meet the stated goals and objectives shall be specified, estimated, or characterized sufficiently for evaluation of the design.

9.13.13.9* Consistency of Assumptions. The design shall not include mutually inconsistent assumptions, specifications, or statements of conditions.

9.13.13.10* Special Provisions. Additional provisions not covered by 9.7.1.1 but that are required for the design to comply with the performance objectives shall be documented.

9.13.14* Design Fire Scenarios.

9.13.14.1 The authority having jurisdiction shall approve the parameters used in design fire scenarios.

9.13.14.2 The proposed design shall be regarded as meeting the goals and objectives if it achieves the performance criteria for each required design fire scenario (*see 9.13.16*).

9.13.15* Evaluation.

9.13.15.1 Design fire scenarios shall be evaluated using a method acceptable to the authority having jurisdiction and appropriate for the conditions expected to be present.

9.13.15.2 Each scenario shall be challenging, but realistic, with respect to at least one of the following scenario specifications:

- (1) Initial fire location
- (2) Early rate of growth in fire severity
- (3) Smoke generation

9.13.16* Required Design Fire Scenarios.

9.13.16.1 Design fire scenarios shall include but not be limited to those specified in 9.13.16.2 through 9.13.16.9.

9.13.16.1.1 Each scenario shall include a life safety aspect (Part A) and a building protection aspect (Part B) when applicable.

9.13.16.1.2 Scenarios demonstrated by the design team to the satisfaction of the authority having jurisdiction as inappropriate for the building use and conditions shall not be required.

9.13.16.2* Design Fire Scenario 1. Design Fire Scenario 1 shall be an occupancy-specific design fire scenario representative of a typical fire for the occupancy.

9.13.16.2.1 This scenario shall explicitly account for the following:

- (1) Occupant activities, number, and location
- (2) Room size
- (3) Nature and significance of furnishings and contents
- (4) Fuel properties and ignition sources
- (5) Ventilation conditions

9.13.16.2.2 The first item ignited and its location shall be explicitly defined.

9.13.16.3* Design Fire Scenario 2. Design Fire Scenario 2 shall be an ultrafast-developing fire in the primary means of egress with interior doors open at the start of the fire.

9.13.16.3.1 Part A. This design fire scenario shall address a reduction of the number of available means of egress.

9.13.16.3.2 Part B. This design fire scenario shall address an increase in the effects of a rapidly spreading fire on interior finish and structural components.

9.13.16.4* Design Fire Scenario 3. Design Fire Scenario 3 shall be a fire that starts in a normally unoccupied room and that potentially endangers a large number of occupants in a large room or other area nearby.

9.13.16.4.1 Part A. This design fire scenario shall address a fire that starts in a normally unoccupied room and migrates into the space that can hold the greatest number of occupants in the building.

9.13.16.4.2 Part B. This design fire scenario shall address a fire that starts in an unoccupied space and that potentially can grow and endanger the area of greatest cultural significance or the most significant elements of the collections.

9.13.16.5* Design Fire Scenario 4. Design Fire Scenario 4 shall be a fire that originates in a concealed wall or ceiling space adjacent to a large number of occupants in a large room.

9.13.16.5.1 Part A. This design fire scenario shall address a fire that originates in a concealed wall or ceiling space that does not have either a detection system or suppression system, and that spreads into the room within the building that potentially can hold the greatest number of occupants.

9.13.16.5.2 Part B. This design fire scenario shall address a fire that originates in a concealed wall or ceiling space with neither a detection system nor a suppression system and that potentially can grow and endanger the area of greatest cultural value or the most significant elements of the collection.

9.13.16.6* Design Fire Scenario 5. Design Fire Scenario 5 shall be a slow-developing fire that is shielded from the fire protection systems and is in close proximity to a high-occupancy area.

9.13.16.6.1 Part A. This design fire scenario shall address a relatively small ignition source that causes a significant fire.

9.13.16.6.2 Part B. This design fire scenario shall address a relatively small ignition source that causes a significant fire that potentially endangers the area of greatest cultural value or the most significant elements of the collection as the result of the delayed suppression of the fire.

9.13.16.7* Design Fire Scenario 6.

9.13.16.7.1 Design Fire Scenario 6 shall be the most severe fire that results from the largest possible fuel load characteristic of the normal operation of the building.

9.13.16.7.2 This section shall address the concern of a rapidly developing fire with occupants present.

9.13.16.8* Design Fire Scenario 7.

9.13.16.8.1 Design Fire Scenario 7 shall be an outside exposure fire.

9.13.16.8.2 This scenario shall address a fire that starts remotely from the area of concern and either spreads into the area, blocks escape from the area, or develops untenable conditions within the area

9.13.16.9* Design Fire Scenario 8. This scenario shall be a fire that originates in ordinary combustibles in a room or area with each passive or active fire protection system rendered unavailable one by one.

9.13.16.9.1 This set of design fire scenarios shall address each fire protection system or fire protection feature, considered individually, being unreliable or unavailable.

9.13.16.9.2* Design Fire Scenario 8 shall not be required for fire protection systems where the level of reliability in conjunction with the design performance in the absence of the system is acceptable to the authority having jurisdiction.

9.13.17 Design Fire Scenario Data.

9.13.17.1 Each design fire scenario used in the performance-based design proposal shall be translated into input data specifications, as appropriate for the calculation method or model.

9.13.17.2 Any design fire scenario specifications that the design analyses do not explicitly address or incorporate, and that are therefore omitted from the data input specifications, shall be identified, and a sensitivity analysis of the consequences of that omission shall be performed.

9.13.17.3 Any design fire scenario specifications modified in input data specifications, because of limitations in test methods, or other data generation procedures shall be identified, and a sensitivity analysis of the consequences of the modification shall be performed.

9.13.18 Evaluation of Proposed Design.

9.13.18.1 A proposed design's performance shall be assessed relative to each performance objective in Section 4.3 and each applicable scenario in Section 9.5, with the assessment conducted through the use of appropriate calculation methods.

9.13.18.2 The authority having jurisdiction shall approve the choice of assessment methods.

9.13.18.3 The design professional shall use the assessment methods to demonstrate that the proposed design will achieve the goals and objectives as measured by the performance criteria in light of the safety margins and uncertainty analysis for each scenario given the assumptions.

9.13.19 Input Data.

9.13.19.1 Input data for computer fire models shall be obtained in accordance with ASTM E1591, *Standard Guide for Obtaining Data for Fire Growth Models*.

9.13.19.2 Data for use in analytical models that are not computer-based fire models shall be obtained using appropriate measurement, recording, and storage techniques to ensure the applicability of the data to the analytical method being used.

9.13.19.3 A complete listing of input data requirements for all models, engineering methods, and other calculation or verification methods required or proposed as part of the performance-based design shall be provided.

9.13.19.4* Uncertainty in input data shall be analyzed and, as determined appropriate by the authority having jurisdiction, addressed through the use of conservative values.

9.13.20* Output Data. The assessment methods used shall accurately and appropriately produce the required output data from input data based on the design specifications, assumptions, and scenarios.

9.13.21 Validity. Evidence shall be provided that confirms the validity and appropriateness of assessment methods used for the proposed building, use, and conditions.

9.13.22* Safety Factors. Approved safety factors shall be included in the design methods and calculations to reflect uncertainty in the assumptions, data, and other factors associated with the performance-based design.

9.13.23* Documentation Requirements.

9.13.23.1 All aspects of the design, including those described in 9.13.24 through 9.13.35, shall be documented.

9.13.23.2 The format and content of the documentation shall be acceptable to the authority having jurisdiction.

9.13.24 Technical References and Resources.

9.13.24.1 The authority having jurisdiction shall be provided with documentation to support the validity, accuracy, relevance, and precision of the proposed methods.

9.13.24.2 The engineering standards, calculation methods, and other forms of scientific information provided shall be appropriate for the particular applications and methodologies used.

9.13.25 Building Design Specifications. All details of the proposed building design that affect the ability of the building to meet the stated goals and objectives shall be documented.

9.13.26 Performance Criteria. Performance criteria, with sources, shall be documented.

9.13.27 Occupant Characteristics. Assumptions regarding occupant characteristics shall be documented.

9.13.28 Design Fire Scenarios. Descriptions of design fire scenarios shall be documented.

9.13.29 Input Data. Input data to models and assessment methods, including sensitivity analysis, shall be documented.

9.13.30 Output Data. Output data from models and assessment methods, including sensitivity analysis, shall be documented.

9.13.31 Safety Factors. Safety factors utilized shall be documented.

9.13.32 Prescriptive Requirements. Retained prescriptive requirements shall be documented.

9.13.33* Modeling Features.

9.13.33.1 Assumptions made by the model user and descriptions of models used, including known limitations, shall be documented.

9.13.33.2 Documentation shall be provided that indicates the validity and appropriateness of the assessment methods used to address the design specifications, assumptions, and scenarios.

9.13.34 Evidence of Modeler Capability. The design team's relevant experience with the models, test methods, databases, and other assessment methods used in the performance-based design proposal shall be documented.

9.13.35 Use of Performance-Based Option. Design proposals shall include documentation that provides anyone involved in ownership or management of the building with notification of the following:

- (1) The building was approved as a performance-based design with certain specified design criteria and assumptions.
- (2) Any remodeling, modification, renovation, change in use, or change in the established assumptions shall require re-evaluation and re-approval.
- (3) All special events shall be reviewed and approved based upon the designs developed under this chapter.

9.13.36 Records. Records required in 9.13.23 shall be maintained for the life of the current performance-based design.

9.13.37 Initial Compliance Audit. The project team shall perform an initial compliance audit upon completion of the implementation phase to ensure compliance with the selected design approach.

9.13.38 Approval. The authority having jurisdiction shall make the final determination as to whether compliance has been achieved.

9.13.39 Periodic Compliance Audit.

9.13.39.1 Periodic compliance audits shall be performed to ensure continued compliance with the selected design approach.

9.13.39.2 Periodic compliance audits and closing conferences shall be conducted in accordance with Section 10.8 through 10.8.2.

9.14* Precautions During New Construction, Addition, Alteration, Renovation, and Modification Projects.

9.14.1* All persons involved with the design of the building, exhibits, and other aspects of the project shall have a demonstrated knowledge of the cultural significance of the structure, the collection, or both.

9.14.2* All persons involved with the construction process shall be thoroughly briefed on the significance and importance of the structure, spaces, character-defining features, and collections prior to the beginning of the work.

9.14.3* Contractor Selection. Contractors selected to work on the project shall have a demonstrated knowledge and experience in working with cultural resource properties.

9.14.4* Contracts. All construction, alteration, renovation, and modification contracts shall specify methods and responsibility for controlling fire hazards.

9.14.5* Initial Meeting/Indoctrination of Contractors.

9.14.5.1 Prior to beginning work on projects, an introductory meeting shall be held with the contractors, subcontractors, and representatives of the cultural resource property.

9.14.5.2 All persons involved in the construction process shall be thoroughly briefed on the significance and importance of the structure, spaces, character-defining features, and collections prior to beginning work.

9.14.5.3 The initial meeting shall cover the project fire safety program, including special protection for existing facilities and contents, emergency precautions, notification of both emergency services and curatorial staff, and security issues pertinent to the project.

9.14.6 Supervision During Construction. The governing body of the cultural resource property shall designate its own representative who shall have the authority to specify additional protection requirements for the construction project necessary to safeguard the existing facility, its contents, and fabric.

9.14.6.1 The governing body's representative shall have the authority to enforce the cultural resource property's protection requirements and to stop work or other activities when they jeopardize the safety or security of the facility or its contents.

9.14.6.2 This supervision shall include the following:

- (1) Site security and monitoring of contractors and visitors
- (2) Isolation of construction from the existing building and collections
- (3) Location and handling of flammable liquid and gases
- (4) Removal of rubbish and combustibles
- (5) Hot work and other sources of ignition
- (6)* Handling of sprinklers and other fire protection system components

9.14.6.3* Following suspension of work each day, the representative or designee shall conduct a walk-through of the work area and surroundings to ensure that the site is secured and fire hazards have been eliminated or controlled.

9.14.7 Control Area.

9.14.7.1 A suitable location at the site shall be designated as a control area and shall be equipped with floor plans, utility control plans, emergency contact telephone numbers, labeled keys, and appropriate material safety data sheets.

9.14.7.2 Where security is of concern, this area shall be locked.

9.14.8 Emergency Communication.

9.14.8.1 Prior to beginning any renovations, modifications, or alterations, workers shall be instructed on emergency communications procedures.

9.14.8.2 A fixed telephone, cellular telephone, or equivalent method of summoning the fire service or local police shall be provided and readily available.

9.14.8.3 The telephone number of the fire service and the local police shall be prominently posted, and shall be on or immediately adjacent to each fixed telephone.

9.14.8.4 Written instructions shall be posted on how to call police for a security breach, notify the local fire service of a fire, and on actions for security officers or other staff to take after the police or fire service have been notified.

9.14.9* Pre-Fire Plan.

9.14.9.1 Access for heavy fire-fighting equipment to the immediate job site shall be provided at the start of construction and maintained until all construction is completed.

9.14.9.2 Free access from the street to fire hydrants and to outside connections for standpipes, sprinklers, or other fire extinguishing equipment, whether permanent or temporary, shall be provided and maintained at all times.

9.14.10 Pedestrian Walkways. Protective pedestrian walkways shall not impede access to hydrants, fire department connections, or fire extinguishing equipment.

9.14.11* Security.

9.14.11.1 Access to construction areas shall be limited to personnel authorized by the owner or contractor.

9.14.11.2* Security officers assigned to the construction areas and the fire safety manager shall receive daily updates from those responsible for construction on the status of and impairments to the fire protection equipment, special hazards including hot work, modified access routes, and emergency procedures.

9.14.11.3 Existing electronic premises security systems and physical security systems shall be maintained in proper working order during the project to the extent consistent with the nature of the construction.

9.14.11.4 Openings that provide access into protected areas in the cultural resource property shall be covered or secured to prevent unauthorized access into the facility.

9.14.11.5 Ladders and stairways on scaffolding that provide access to upper levels of the cultural resource property shall be secured to prevent unauthorized persons from using the scaffolding to gain access to the facility.

9.14.12 Protection System Impairments.

9.14.12.1 The provisions of Section 12.4 shall apply when fire protection systems or equipment are taken out of service.

9.14.12.2 The provisions of Section 12.5 shall apply when electronic premises protection systems are taken out of service.

9.14.13 Fire Protection Systems.

9.14.13.1 Fire Alarm Systems.

9.14.13.1.1 Existing fire detection and alarm systems shall be maintained in proper working order during the project to the extent consistent with the nature of the construction.

9.14.13.1.2* Protection During Construction.

9.14.13.1.2.1 Where detectors are installed for signal initiation during construction, they shall be cleaned and verified to be operating in accordance with the listed sensitivity, or they shall be replaced prior to the final acceptance test of the system. [72:17.7.1.11.1]

9.14.13.1.2.2 Where detectors are installed but not operational during construction, they shall be protected from construction debris, dust, dirt, and damage in accordance with the manufacturer's recommendations and verified to be operating in accordance with the listed sensitivity, or they shall be replaced prior to the final acceptance test of the system. [72:17.7.1.11.2]

9.14.13.1.2.3 Where detection is not required during construction, detectors shall not be installed until after all other construction trades have completed cleanup. [72:17.7.1.11.3]

9.14.13.1.3 Smoke detectors used in temporary detection systems inside the construction area that are covered to keep out dust and dirt while work is in progress shall be uncovered at the end of each work day.

9.14.13.1.4 After final construction cleanup by all trades, all smoke detectors shall be cleaned or replaced.

9.14.13.1.5 Reacceptance testing in accordance with *NFPA 72* shall be performed after any adjustment, modification, or repair to any system wiring or component.

9.14.13.2 Fire Suppression Systems.

9.14.13.2.1 During construction operations, free access to permanent, temporary, or portable fire extinguishing equipment and systems shall be maintained.

9.14.13.2.2* Water for fire suppression shall be available throughout all phases of construction.

9.14.13.2.3 Disconnected or shut off standpipes or fire suppression systems shall be restored to service as soon as it is practical.

9.14.13.2.4* Fire hydrants, sprinklers, standpipes and sprinkler fire department connections, and hose outlet valves shall not be obstructed.

9.14.13.3 Standpipes.

9.14.13.3.1 New standpipes that are required or existing standpipes in buildings being altered shall be maintained in accordance with the progress of building activity so that the standpipes are always ready for fire department use.

9.14.13.3.2 Class I manual dry standpipes shall be permitted where approved by the authority having jurisdiction.

9.14.13.3.3 Where required by the responding fire department, hose and nozzles shall be provided and maintained ready for use as soon as either a temporary or permanent water supply is available.

9.14.13.4 Automatic Fire Suppression Systems.

9.14.13.4.1 Where automatic fire suppression systems are provided, the installation shall be placed in service and monitored as soon as it is practical.

9.14.13.4.2 Where fire suppression systems existed prior to the rehabilitation project, the system shall be kept in service as long as possible during the rehabilitation work.

9.14.13.4.3 Where fire suppression systems must be taken out of service for modification, the local fire department shall be notified and the system shall be returned to service as soon as possible.

9.14.13.4.4 Automatic fire suppression systems shall be kept in proper working order during the project to the extent consistent with the nature of the construction.

9.14.13.5 Portable Fire Extinguishers.

9.14.13.5.1 Portable fire extinguishers shall be provided in accordance with *NFPA 10*.

9.14.13.5.2* Not less than one portable fire extinguisher as required by 9.14.13.5.1 shall be provided on each floor near each usable stairway.

9.14.13.5.3 Portable fire extinguishers shall be accessible and protected from accidental damage.

9.14.14 Separation of Construction Areas.

9.14.14.1 Each construction area shall be isolated by partitions that will resist the spread of fire to other parts of the building.

9.14.14.2 Fire walls and exit enclosures required for the completed building shall be given priority during construction.

9.14.14.3 Fire doors with approved closing devices and hardware shall be installed as soon as practical and before combustible materials are introduced.

9.14.14.4 Fire doors shall not be obstructed from closing.

9.14.14.5 Environmental Conditions. Openings in structures susceptible to damage from high winds that could cause skewing and misalignment of the structure, disruption of water supplies or delivery systems for fire protection, or malfunction of the building's electronic premises security systems shall have secure coverings.

9.14.15 Egress.

9.14.15.1 Required exits and normal guard routes shall be maintained or supplementary routes provided.

9.14.15.2 Where construction blocks an exit route, adjoining spaces shall also be closed, as necessary, to avoid excessive crowding in common paths of travel or dead ends.

9.14.15.3 At least one stairway shall be provided in usable condition at all times in multistory buildings.

9.14.16 Ignition Sources.

9.14.16.1 Hot work operations shall comply with 9.14.23.

9.14.16.2 Portable heating appliances shall comply with 9.14.25.

9.14.16.3 On-site recharging of gas cylinders shall be prohibited.

9.14.16.4 Temporary lighting and wiring shall comply with the requirements of *NFPA 70*.

9.14.16.5* Only fluorescent lighting shall be used as temporary lighting.

9.14.17 Smoking. Smoking shall be prohibited or restricted to designated areas.

9.14.17.1 Smoking shall be prohibited inside any building or building space or area under construction, renovation, modification, or repair.

9.14.17.2 Where smoking is allowed, the governing body of the cultural resource property shall designate a smoking area outside of the work area where contractors and workers are permitted to smoke.

9.14.17.2.1 The designated smoking area shall be clearly and publicly identified and shall be located a sufficient distance away from all combustible and flammable materials or liquids to prevent a fire from starting.

9.14.17.2.2 Receptacles for spent smoking materials shall be provided in the designated smoking area.

9.14.17.2.3 A portable fire extinguisher, in compliance with the provisions of *NFPA 10* shall be located at each designated smoking area.

9.14.17.2.4 If located inside the cultural resource property, the smoking area shall fully comply with all of the requirements of Section 11.5.

9.14.18 Flammable and Combustible Liquids.

9.14.18.1 No more than a 1-day supply of paint thinners, solvents, and other flammable and combustible liquids used in the project shall be kept in the building.

9.14.18.2 Flammable liquids shall be stored in approved safety cabinets and containers.

9.14.18.3 Quantities of flammable and combustible liquids in excess of those necessary to complete a day's work shall be stored at least 15 m (50 ft) away from the main construction project.

9.14.18.4 Gasoline-powered engines, such as those used in compressors and hoists, shall not be permitted inside the building.

9.14.19 Electrical Systems.

9.14.19.1 Prior to construction, the electrical equipment and circuits that might be impacted by the alteration, addition, renovation, or modification work shall be identified, relocated, and made safe by a qualified person.

9.14.19.2 Electrical wiring and equipment shall be installed in compliance with the requirements of *NFPA 70*.

9.14.19.3 Temporary lighting, bulbs, and fixtures shall be installed so they do not come in contact with combustible materials.

9.14.19.4 Circuit breakers for circuits that are not in use shall be shut off.

9.14.19.5 Temporary wiring shall be removed immediately upon elimination of the need for which the wiring was installed.

9.14.20 Construction Offices, Trailers, and Sheds.

9.14.20.1 Construction offices, trailers, sheds, and other temporary facilities of combustible construction shall comply with Section 4.1 of *NFPA 241*.

9.14.20.2 Heating devices used in construction offices and sheds shall be listed for the purpose.

9.14.20.3* A minimum clearance of 1 m (39 in.) shall be maintained around stoves and heaters, and a minimum clearance of 150 mm (6 in.) shall be maintained around all chimney and vent connectors to prevent ignition of adjacent combustible materials.

9.14.20.4 Structures, equipment, and materials shall not impede egress of occupants or workers from the building or hinder access by fire apparatus to hydrants and fire department connections or to the building by emergency response personnel or damage limitation teams.

9.14.20.5 The areas beneath all temporary offices and other facilities shall not be used for the storage of construction materials, equipment, or supplies, and measures shall be put in place to ensure that no combustible waste matter is allowed to accumulate in these areas.

9.14.21 Construction Equipment.

9.14.21.1 Internal combustion engine-powered air equipment, such as compressors, hoists, derricks, and pumps, shall be placed so the exhaust discharges away from combustible materials and air intakes for the building heating, ventilation, and air-conditioning (HVAC) system.

9.14.21.2 A minimum clearance of 150 mm (6 in.) shall be maintained between equipment exhaust piping and combustible materials.

9.14.21.3 Service areas and fuel for construction equipment shall not be located inside the building.

9.14.22* Construction Materials.

9.14.22.1* Flammable and combustible liquids shall comply with 9.14.18.

9.14.22.2 Combustible construction components stored inside the building shall be strictly limited to that necessary for that day's work.

9.14.22.3 Where construction is to be of protected steel, combustible storage shall not be placed in areas where specified fire-resistive coatings have not been applied to structural members.

9.14.22.4 Storage of highly combustible materials such as foam, plastic, and rubber products shall not be permitted inside the building.

9.14.22.5 Storage of construction materials shall not impede egress from buildings or access of fire apparatus to hydrants or to the building.

9.14.22.6 Tarpaulins or plastic sheeting, if used, shall be noncombustible or of a fire-retardant variety.

9.14.23 Welding, Cutting, and Other Hot Work Operations.

9.14.23.1 Welding, cutting and other hot work operations shall comply with the requirements of NFPA 51B.

9.14.23.2 The person designated to be in charge of fire protection shall issue a hot work permit each day that cutting, welding, and other hot work are being conducted as required by Section 11.6.

9.14.23.3* At the close of the workday the person responsible for fire protection on the site shall inspect areas where welding, cutting, or other hot work operations have been conducted for hot metal or smoldering combustible materials.

9.14.23.4 Flammable gas cylinders used in the welding or cutting process shall be protected from vehicle damage and high temperatures.

9.14.24 Plumbing.

9.14.24.1 Plumbing work involving open flames shall be conducted only under the supervision of the person in charge of fire protection and shall require a hot work permit reissued each day.

9.14.24.2 The provisions of 9.14.23 shall apply for cutting and welding operations.

9.14.25 Temporary Heating Equipment.

9.14.25.1 Temporary heating equipment shall be listed for the purpose and used and installed in accordance with the listing.

9.14.25.2 Temporary heating equipment shall comply with NFPA 54, NFPA 31, and NFPA 211.

9.14.25.3 Temporary heating devices shall be used only on a stable surface in a protected location where the equipment will not be overturned.

9.14.25.4 Portable equipment using oil or liquefied petroleum gas as fuel shall be moved to a well-ventilated area away from combustible material and allowed to cool prior to refueling.

9.14.25.5* The travel distance from all portable heating devices to not less than one portable fire extinguisher complying with NFPA 10 shall not exceed 9 m (30 ft).

9.14.25.6 Chimney or vent connectors from direct-fired heaters, where required, shall be maintained at least 457 mm (18 in.) from combustible materials.

9.14.25.7 Temporary heating equipment shall be attended and maintained by trained personnel.

9.14.26 Roofing.

9.14.26.1 Tar Kettles.

9.14.26.1.1 Tar kettles used in roofing shall comply with Section 16.7 of NFPA 1.

9.14.26.1.2* Fire extinguishers shall be located as required in 16.7.1.6 of NFPA 1.

9.14.26.2 Liquefied Petroleum Gas (LPG).

9.14.26.2.1 Cylinders or containers used for fueling tar kettles shall be protected against tampering and vandalism.

9.14.26.2.2 Containers shall be kept 6 m (20 ft) from combustible materials or spare containers.

9.14.26.2.3 When possible, cylinders and containers shall be placed in a secured area for protection against tampering.

9.14.26.2.4 Cylinders or containers that cannot be secured in a protected area shall have the dome covers locked and secured, or the valve handle shall be removed or secured in the off position.

9.14.26.2.5 Storage of LP-Gas cylinders on rooftops shall not be permitted.

9.14.26.2.6 Used roofing mops shall not be stored inside the building.

9.14.27 Demolition Work.

9.14.27.1 Gas supplies shall be shut off at a point outside the affected area and shall be capped.

9.14.27.2 Electrical service shall be reduced or eliminated in the affected area.

9.14.27.3 Hot work shall not be permitted in combustible buildings except as outlined in Section 11.6.

9.14.27.4 Fire walls, fire doors, cutoffs, and other fire separation assemblies shall be maintained intact where possible.

9.14.28 Other Hazardous Operations. The fire safety manager shall conduct an assessment of operations that introduce fire hazards to determine if the risk is consistent with the facility's fire safety objectives.

9.14.28.1 Paint-stripping operations that involve heat-producing devices shall not be permitted.

9.14.28.2 Floor sander dust accumulation bags shall be emptied into closed metal containers outside of the building before the close of the day.

9.14.29 Housekeeping.

9.14.29.1 The accumulation of debris or rubbish shall not be permitted inside construction areas or close to a source of ignition.

9.14.29.2 Debris and rubbish shall be removed daily from the site and shall not be burned in the vicinity.

9.14.29.3 Contractors shall provide receptacles for rubbish, papers, and other debris.

9.14.29.4 A chute for the removal of debris shall be erected on the outside of the building.

9.14.29.5 Burning waste materials on the premises shall not be permitted.

Chapter 10 Management Operational Systems

10.1* General.

10.1.1* This chapter shall establish criteria for management operational systems that are acceptable as elements of a prescriptive solution or performance-based approach as provided in Section 1.5.

10.1.2 Other operational control features shall be permitted subject to the approval of the authority having jurisdiction.

10.2 Responsibility/Authority.

10.2.1 The owner, governing board, or other body having custody over the building shall designate a fire safety manager and security manager.

10.2.2 The fire safety manager shall have the authority to implement all the fire safety components of the approved protection plan including, but not limited to, the following:

- (1) Directing the actions of the building staff and occupants with regard to fire safety
- (2) Entering into legally binding contractual agreements with the authority having jurisdiction
- (3) Ordering required fire safety drills and exercises
- (4) Halting contractor and maintenance operations that might threaten the fabric or contents of the building

10.2.3 The security manager shall have the authority to implement all the security components of the approved protection plan.

10.3 Reporting Incidents.

10.3.1* All incidents including, but not limited to, fires, criminal acts, damage to property, or other intentional or accidental

acts or conditions with the potential to cause harm, however small, shall be reported to the fire safety manager, the security manager, or to both. In addition, all fires shall be reported to the local fire department and all criminal activity shall be reported to the local law enforcement agency.

10.3.2 When a crime occurs or a fire is deemed suspicious, the security manager, fire safety manager, or both shall take steps to ensure that the scene is secured pending investigation.

10.4 Operational Requirements.

10.4.1* Operational controls, or a plan of operations, shall be developed that include all special provisions that are granted as part of a performance-based or a prescriptive-based approach in evaluating the building as defined by the planning team (*see Chapter 9*) and as approved by the authority having jurisdiction.

10.4.2* Operational controls shall include the special provisions pertaining to the management, operations, and stewardship of the cultural resource property, its collections, and other culturally significant objects or architectural features.

10.4.3* Operational controls shall be defined as part of the protection plan.

10.4.4 Procedures for Opening and Closing. The protection plan shall include checklists that identify specific activities required in conjunction with opening and closing the building on a daily basis and for any special events that are held on the property.

10.5 Emergency Response. The fire safety manager and the security manager shall implement the emergency operations component of the protection plan developed in accordance with Chapter 6 and shall be responsible for periodic testing and evaluation of emergency operations procedures; for regularly updating the protection plan to accommodate changes in staff, the facility, the operations, or to address deficiencies identified in testing the emergency operations procedures; and for ensuring continued compliance with agreed upon operational controls.

10.6 Training.

10.6.1 The fire safety manager, security manager, building staff, and volunteers shall be trained as agreed upon with the authority having jurisdiction.

10.6.2 At a minimum, training shall include the provisions of the fire safety management, security, and emergency operations components of the protection plan.

10.6.3 Drills.

10.6.3.1 Drills shall be conducted to reinforce training and to evaluate staff and volunteer preparedness at intervals agreed upon by the fire safety manager, security manager, and the authority having jurisdiction but not less than annually.

10.6.3.2 Where required, the authority having jurisdiction shall be notified in advance of all drills.

10.6.4 Additional training shall be obtained when any of the following conditions occur:

- (1) The use, occupancy, structure, or internal layout of the building changes.
- (2) Drills indicate that staff or volunteers are not sufficiently familiar with the facility's protection plan and equipment to respond properly under emergency conditions.

- (3) Special events that introduce unusual occupancies or conditions are scheduled.
- (4) Portable fire extinguishers constitute a part of the protection plan.
- (5) New materials, substances, or products are introduced into the building.

10.7 Documentation.

10.7.1 The fire safety manager shall be responsible for maintaining a current file of the cultural resource property's fire safety records (*see Section 7.4*).

10.7.2 The security manager shall be responsible for maintaining a current file of the security training and drills.

10.7.3 All records shall be made available to the authority having jurisdiction on request.

10.8 Compliance Audit.

10.8.1 The authority having jurisdiction or its designee shall conduct a compliance audit at intervals identified in the approved protection plan but not less than annually.

10.8.2 Additional compliance audits shall be conducted prior to special events (*see Chapter 13*).

10.8.3 Closing Conference.

10.8.3.1 Upon completion of the periodic compliance audit, the authority having jurisdiction or its designee shall conduct a closing conference with the fire safety manager or the individual or group designated by the governing body as responsible for planning protection for the cultural resource property.

10.8.3.2 The closing conference shall identify all areas of noncompliance with the approved protection plan.

10.8.3.3 Following the periodic compliance audit, any deficiencies shall be addressed, with corrective action taken and documented in the fire safety log or as specified in the cultural resource property's approved protection plan.

10.9 Enforcement. Where a compliance audit reveals noncompliance with the approved protection plan, or changes in the use or arrangement of the building, the authority having jurisdiction shall be notified.

10.10 Modification of the Plan. Proposed modifications to the protection plan shall be approved by the authority having jurisdiction.

Chapter 11 Fire Prevention

11.1* General. This chapter shall outline the minimum protection criteria necessary for protection of cultural resource properties.

11.2 Decorations.

11.2.1 Decorative materials, including those used for special events, occasions, and holidays, shall be noncombustible or shall comply with the fire performance requirements of NFPA 1 for assembly occupancies.

11.2.2 Decorations shall be kept a minimum of 1 m (36 in.) from ignition sources, such as light fixtures, radiators, candles, electric heaters, and other heat-generating devices.

11.2.3 Draperies, curtains, and other similar loosely hanging furnishings and decorations shall meet the flame propagation performance criteria contained in NFPA 701.

11.2.4* Fire-retardant treatment of historically significant fabrics shall not be required where such treatment will cause damage to the fabric. This provision shall apply only on an object by object basis and where alternate protection measures are approved.

11.2.5 The use of Christmas trees and other decorative vegetation shall be in accordance with NFPA 1.

11.3* Fire Spread Control.

11.3.1 Interior doors shall be kept closed when the building is not occupied except as permitted in 11.3.2.

11.3.2 Where doors are required to remain open for interior ventilation and air movement concerns are critical to the conservation of historic building fabric, collections, or both, or where the interior doors are themselves part of the historic fabric, careful and professional analysis of the open doors' impact shall be performed, and documented alternative methods to control fire spread shall be implemented.

11.4* Housekeeping.

11.4.1 Stairwells, corridors, doorways, and any other portions of the means of egress for a building shall be maintained free of combustibles, trash containers, and other materials.

11.4.2 Attics.

11.4.2.1 Attic spaces shall be kept clean, free of combustibles, and locked.

11.4.2.2 Combustible materials shall be permitted to be stored in attics protected by automatic suppression systems designed to allow such storage.

11.4.3* Electrical rooms, mechanical rooms, and telephone closets shall be kept free of combustibles and locked.

11.4.4 Stacks, exhaust ducts, and filters shall be cleaned as frequently as necessary to prevent the buildup of combustible dusts and fibers.

11.4.5 Plenums and void spaces shall not be used for storage and shall be kept clean and free of combustibles.

11.4.6 Rags, clothing, and waste material contaminated with oils, such as animal or vegetable oils, paints, thinners, wax, furniture polish, and other liquids or compounds that could cause spontaneous heating, shall be isolated from other combustibles in metal containers with tight-fitting metal lids.

11.4.7 Ventilated metal lockers shall be provided for storage of highly combustible supplies and workers' clothing contaminated with combustible or flammable liquids.

11.4.8 Packing Materials.

11.4.8.1 Combustible packing materials, such as shredded paper, foamed polystyrene packing material ("peanuts"), plastic, and excelsior, shall be stored in metal containers with self-closing covers.

11.4.8.2 Where packing materials cannot be protected using metal containers with self-closing covers, dedicated crating and packing areas shall be enclosed by fire barriers having a fire

resistance rating of not less than 1 hour or shall be equipped with sprinklers.

11.4.9 Trash shall be collected and disposed of at the end of each workday and more often if necessary.

11.4.10 Dumpsters used for bulk collection of trash or recyclable paper shall be constructed of metal with metal covers.

11.4.11 Dumpsters and other large trash containers inside buildings shall be stored in one of the following ways:

- (1) In trash rooms having both automatic sprinklers and a 1-hour fire resistance rating
- (2) In loading dock areas separated from the rest of the building with a 2-hour fire resistance rating or 1-hour fire resistance rating and protected with automatic sprinklers

11.4.12* Trash containers, dumpsters, and other central waste-disposal units located outside shall be kept at a minimum distance of 4.6 m (15 ft) from all parts of a building exterior, including but not limited to windows, doors, roof eaves, and utility controls.

11.5* Smoking. Smoking shall be prohibited inside buildings except in designated areas that meet the following requirements:

- (1) Smoking areas shall be clearly and publicly identified.
- (2) Smoking areas shall be provided with suitable ashtrays and other receptacles for the proper disposal of smoking materials.
- (3) Smoking areas shall be physically separated from the rest of the building with a minimum 1-hour fire resistance rating for walls, ceilings, and floors.
- (4) Portable fire extinguishers shall be provided in accordance with NFPA 10 at each designated smoking area.

11.6 Hot Work.

11.6.1 Limitations on Hot Work Operations.

11.6.1.1 Hot work shall not be permitted in or near the premises, unless there is no other viable alternative.

11.6.1.2* Where there is no other viable alternative to conducting hot work on the premises, such hot work shall comply with the requirements of NFPA 51B.

11.6.2 Hot Work Permit.

11.6.2.1 A hot work permit, issued by the fire safety manager or designee, shall be required to authorize work with any open flame devices used in soldering, brazing, cutting, welding, or paint removal.

11.6.2.2 The hot work permit shall prescribe measures to protect the collections.

11.7 Open Flames.

11.7.1 Approval. Use of open flames and flame-producing devices, such as candles, oil lamps, fireplaces, forges, kilns, glassblowers, and cook stoves shall be approved by the authority having jurisdiction.

11.7.2 Precautions. The following precautions shall be taken to control open flame and flame-producing devices:

- (1) All employees working around open flame or flame-producing devices shall be trained in the proper use and operation of the device and in emergency response procedures.
- (2) Open flames and flame-producing devices shall be monitored constantly by a trained person.
- (3) The travel distance from any area where open flames or flame-producing devices are in use to not less than one portable fire extinguisher complying with NFPA 10 shall not exceed 9 m (30 ft).
- (4) Candles shall be kept a minimum of 1.25 m (4 ft) from combustible window treatments and wall or ceiling hangings.
- (5) Fireplaces shall be covered with a fire screen when not used for cooking or similar demonstrations.
- (6) Open flames within 31 m (100 ft) of the building shall not be left unattended.
- (7) Open flames either inside or outside the building shall be extinguished prior to shutdown of the facility.

11.7.3 Chimneys.

11.7.3.1 Chimneys that serve active fireplaces or stoves shall be provided with a spark arrester and maintained in good working order in accordance with the provisions of NFPA 211.

11.7.3.2 Chimneys that serve active fireplaces or stoves shall be inspected and cleaned annually by a competent person in accordance with the provisions of NFPA 211.

11.7.3.3 Vegetation within 3050 mm (10 ft) of a chimney outlet shall be removed.

11.8 Electrical Hazards.

11.8.1 Electrical circuits shall be protected with an arc fault circuit interrupter in accordance with *NFPA 70*.

11.8.2 Portable electrical appliances shall be provided with thermal and electrical limit controls that will cause the appliance to fail in a safe condition.

11.8.3 Temporary wiring, including extension cords, shall comply with the requirements of *NFPA 70*.

11.8.4 Decorative lighting and similar accessories used for holiday lighting and similar purposes shall comply with Articles 410 and 590 of *NFPA 70*.

11.8.5 Cabling. Readily accessible cabling installations for all systems within the property shall be inspected for physical damage, missing box covers, electrical overloading, and connection integrity in compliance with *NFPA 70*.

11.9 Penetrations. The fire safety manager shall inspect the cultural resource property regularly to ensure penetrations through fire barriers or fire walls are sealed according to the applicable code.

11.10 Structural Fire Protection. The fire safety manager shall inspect accessible structural fire protection regularly to ensure the material is in place and maintained in good condition.

11.11* Lightning Protection. The fire safety manager shall ensure that the lightning protection system, where installed, is inspected and maintained in good working condition by qualified personnel. (*See NFPA 780.*)

11.12 Protection from Wildland Fires.

11.12.1* The governing body of a cultural resource property located in a wooded area or surrounded by fire-prone vegetation or heavy brush shall incorporate the requirements of NFPA 1144 into the fire safety management component of the protection plan.

11.12.2 Reduction of fuel loading in the landscape surrounding and owned by the cultural resource property shall be implemented in accordance with the requirements of NFPA 1144.

11.12.3 Where the landscape is historic and either a contributing element to the property's historic designation, or designated itself, the governing body shall obtain the evaluation and recommendation of a professional historic landscape architect for reducing fire loading that could threaten either the cultural resource property or the historic landscape.

11.12.3.1 The evaluation shall include an analysis with respect to the requirements of NFPA 1144.

11.12.3.2 The resulting recommendations of the evaluation shall be included in the fire safety management component of the protection plan.

11.12.4 Access roads shall be maintained and kept fully accessible at all times to accommodate fire service vehicles.

11.13 Water Control. Provisions shall be made for removal of accumulated water from manual and automatic fire-fighting operations.

Chapter 12 Inspection, Testing, and Maintenance of Protection Systems

12.1* General. This chapter shall establish requirements for inspection, testing, and maintenance of protection systems of cultural resource properties.

12.2 Fire Protection Systems.

12.2.1 Fire protection systems shall be inspected, tested, and maintained in accordance with the manufacturer's recommendations and the applicable requirements of NFPA 4, NFPA 25, and NFPA 72, and any applicable standard from Table 9.12.14.

12.2.2 Responsibility.

12.2.2.1 The governing body of the cultural resource property shall be responsible for the inspection, testing, and maintenance of fire protection systems.

12.2.2.2 Inspection, testing, and maintenance shall be implemented in accordance with procedures meeting or exceeding those established in the standard for that type of fire protection system and in accordance with the manufacturer's instructions.

12.2.2.3 Service personnel shall be qualified and experienced in the inspection, testing, and maintenance of fire alarm systems. Qualified personnel shall include, but not be limited to, one or more of the following:

- (1) Personnel who are factory trained and certified for fire alarm system service of the specific type and brand of system
- (2) Personnel who are certified by a nationally recognized fire alarm certification organization acceptable to the authority having jurisdiction

- (3) Personnel who are registered, licensed, or certified by a state or local authority
- (4) Personnel who are employed and qualified by an organization listed by a nationally recognized testing laboratory for the servicing of fire alarm systems

12.2.3* Inspection. Inspection and testing frequencies, responsibilities, test routines, and reporting procedures shall comply with the applicable code or standard from Table 9.12.14, NFPA 25, and NFPA 72.

12.2.4 Testing. All fire protection systems shall be tested to verify that they function as intended.

12.2.4.1 Test results shall be compared with those of the original acceptance test (if available) and with the most recent test results.

12.2.4.2 Records shall be retained for the next test and for 1 year thereafter.

12.2.5 Maintenance.

12.2.5.1 Maintenance shall be performed to keep all fire protection systems operable, and necessary repairs shall be made.

12.2.5.2 As-built system installation drawings, original acceptance test records, and device or equipment manufacturer's maintenance bulletins shall be retained by the fire safety manager to assist in the developing and maintaining of the inspection, testing, and maintenance standards for all fire protection equipment, systems, and components.

12.3 Electronic Premises Security Systems.

12.3.1 All electronic premises security systems shall be tested, inspected, and maintained in compliance with the manufacturer's recommendations.

12.3.2 Personnel who have developed competence through training and experience shall perform inspection, testing, and maintenance of electronic premises security systems.

12.3.3* Inspection. Inspection and testing frequencies and test routines shall comply with the manufacturer's recommendations.

12.3.4 Testing. All electronic premises security systems shall be tested to verify that they function as intended.

12.3.4.1 Test results shall be compared with the original specifications for the system, the results of the original acceptance test (if available), and with the results of the most recent test. Any variances in the performance of the system shall be documented and corrections made to bring system performance to an acceptable level.

12.3.4.2 Records shall be retained for the next test and for 1 year thereafter.

12.3.5 Maintenance.

12.3.5.1 Maintenance shall be performed to keep all electronic premises security systems operable, and necessary repairs shall be made.

12.3.5.2 The security manager shall retain as-built system installation drawings, original acceptance test records, and device or equipment manufacturer's maintenance bulletins to assist in the developing and maintaining of the inspection, test-

ing, and maintenance standards for all electronic premises security equipment, systems, and components.

12.4 Impairments to Fire Protection Systems.

12.4.1 General. When an emergency or a preplanned activity takes any fire protection system out of operational service, measures shall be taken during the impairment to ensure that increased risks are minimized and the duration of the impairment is limited.

12.4.1.1 Where fire protection systems such as sprinkler systems, fire pumps, and fire detection and alarm systems are out of service for 4 hours or more, the fire safety manager shall notify the fire department and post a fire watch.

12.4.1.2 The fire watch shall be provided with an approved means to notify the fire department.

12.4.2 Planned Impairments.

12.4.2.1 The fire safety manager shall authorize all preplanned impairments in advance of work.

12.4.2.2* The fire safety manager shall be responsible for verifying that written procedures for impairments are in place before authorizing a system impairment.

12.4.3 Procedure.

12.4.3.1 A written procedure shall be established and implemented by the fire safety manager to control any emergency or preplanned impairment.

12.4.3.2 The procedure shall include not less than the following:

- (1) Identification and tagging of all impaired equipment and systems
- (2) Inspection and risk evaluation
- (3) Identification of extent or expected duration of impairment
- (4) Notification of fire department
- (5)* Notification of other personnel or organizations as appropriate
- (6)* Statement of additional measures deemed necessary for the duration of the impairment of the systems
- (7)* Actions and notifications to be taken when all impaired equipment and systems are restored to operational service
- (8) Prior to preplanned impairment, assembly of all necessary parts, tools, materials, and labor at the impairment site before the system or equipment is removed from service
- (9) Expedition of all repair work

12.4.4 Restoring Systems to Service. When all impaired systems are restored to operational service, the fire safety manager shall verify that the following items have been completed:

- (1) Any necessary inspections and tests required by the appropriate section of the applicable standards referenced in Section 9.12 for the fire protection system or equipment involved have been conducted to verify that affected systems and equipment are operational.
- (2) Those individuals notified in accordance with 12.4.3.2 have been advised that protection has been restored.
- (3) Impairment tags have been removed.

12.5 Impairments to Electronic Premises Security Systems.

12.5.1 General. When an emergency or a preplanned activity takes any electronic premises security system out of operational service, measures shall be taken during the impairment to ensure that increased risks are minimized and to limit the duration of the impairment.

12.5.1.1* Where electronic premises security systems out of service for 4 hours or more, the security manager shall post security personnel or make other arrangements for security until the systems are restored.

12.5.1.2 Security personnel shall be provided with an approved means to notify the local police.

12.5.2 Planned Impairments.

12.5.2.1 The security manager shall authorize all planned impairments in advance of work.

12.5.2.2* The security manager shall be responsible for verifying that written procedures for impairments are in place before authorizing a system impairment.

12.5.3 Procedure.

12.5.3.1 A written procedure shall be established and implemented by the security manager to control any emergency or planned impairment.

12.5.3.2 This procedure shall include, as a minimum, the following:

- (1) Identification and tagging of all impaired equipment and systems
- (2) Inspection and risk evaluation
- (3) Identification of extent or expected duration of impairment
- (4) Notification of police department
- (5)* Notification of other personnel or organizations as appropriate
- (6)* Statement of additional measures deemed necessary for the duration of the impairment of the systems
- (7)* Actions and notifications to be taken when all impaired equipment and systems are restored to operational service
- (8) Prior to planned impairment, assembly of all necessary parts, tools, materials, and labor at the impairment site before the system or equipment is removed from service
- (9) Expedition of all repair work

12.5.4 Restoring Systems to Service. When all impaired systems are restored to operational service, the security manager shall verify that the following items have been completed:

- (1) Any necessary inspections and tests required by NFPA 731 have been conducted to verify that affected systems and equipment are operational.
- (2) Those individuals notified in accordance with 12.5.3.2(5) have been advised that protection has been restored.
- (3) Impairment tags have been removed.

12.6 Heating, Air-Conditioning, and Cooking Equipment.

12.6.1 Heating, air-conditioning systems, and cooking appliances shall be maintained in accordance with the manufacturer's specifications and shall comply with NFPA 90A, NFPA 90B, and NFPA 96.

12.6.2 Heaters and ductwork, including hoods and ducts for ranges, shall be kept free of flammable and combustible deposits.

12.7 Chimneys. Chimneys for active stoves or fireplaces shall be inspected and cleaned annually in compliance with the requirements of NFPA 211.

12.8* Electrical Systems. Electrical systems shall be maintained in compliance with *NFPA 70* and the manufacturer's instructions.

12.9 Fire Barriers. The integrity of fire barriers shall comply with the applicable building code.

12.10 Fire Retardant–Treated Materials. Applied coatings and treatments shall be maintained in accordance with NFPA 703.

12.11 Fire Extinguishers. Portable fire extinguishers shall be inspected, tested, and maintained in accordance with NFPA 10.

Chapter 13 Special Events

13.1* General. Plans for special events shall be reviewed and approved by the fire safety manager and the security manager. A vulnerability assessment shall be conducted for each special event, and security procedures appropriate to the risk shall be developed.

13.2 Occupant Loading.

13.2.1 The event coordinator shall ensure that the number of occupants admitted to the building is monitored and controlled so that the occupant load does not exceed the capacity of the means of egress, nor for the number of exits required by the applicable building code, fire code, or life safety code.

13.2.2 Orderly circulation of guests shall be maintained when special events are planned for large groups.

13.3 Means of Egress.

13.3.1 Exits, access to exits, and all other evacuation capabilities shall be maintained.

13.3.2 Tables, plants, stages, or other temporary fixtures shall not visually or physically obstruct an exit, exit sign, or exit access, or reduce the width of an exit passage.

13.3.3 Prior to performance or event, staff (especially temporary or part-time staff), contractor personnel, attendees, and participants shall be notified of the following:

- (1) How fire alarms are annunciated (i.e., audibly, visually, by voice communication, or a combination of these methods)
- (2) Locations of exit routes, exits, and assembly points
- (3) How to safely evacuate the area

13.3.4 Key staff, including event coordinators, volunteers, and security, shall be familiar with exit routes and shall ensure that exits are obvious, operable, and not blocked or restricted in any way.

13.3.5 Upon activation of the fire alarm, occupants shall be evacuated from the building according to the egress plan.

13.4 Cooking Equipment.

13.4.1 Cooking and food warming shall be undertaken only in facilities built for the purpose, and only electric food-warming equipment shall be used in other areas.

13.4.2 All cooking and food warming shall be closely supervised at all times.

13.4.3 Not less than one portable fire extinguisher shall be located within 3050 mm (10 ft) of any cooking, food-warming, or related operation and shall be identified clearly.

13.4.4 Fire extinguishers provided for the protection of cooking appliances that use combustible cooking media (vegetable or animal oils and fats) shall be listed and labeled for Class K fires and installed in accordance with NFPA 10.

13.5 Smoking. Smoking shall be prohibited except as permitted in Section 11.5.

13.6 Fireworks. Demonstrations of fireworks shall be held outside the building or structure and shall conform to NFPA 1123.

13.7 Combustibles.

13.7.1 Tents and canopies shall be noncombustible or certified as having been treated with an approved fire-retardant coating.

13.7.2 Draperies, bunting textiles, wood, and miscellaneous support and decorative materials used inside the building shall be noncombustible, impregnated with an approved fire retardant, or treated with an approved fire-retardant coating.

13.8 Electrical Equipment.

13.8.1 Electrical appliances and equipment, including temporary installations, shall be listed, and wiring shall comply with *NFPA 70*.

13.8.2 Exposed electrical wiring and extension cords shall not be placed across travel or exit routes.

13.8.3 A licensed or registered electrician shall verify that electrical circuits do not exceed their rated capacity.

13.9 Access Control.

13.9.1 Systems for controlling access to sensitive or high-value areas shall be maintained to prevent unauthorized access to culturally significant collections.

13.9.2 Areas intended for public access shall be clearly delineated to prevent unintended intrusions into protected areas.

13.9.3 Security or event staff shall be stationed where they can observe ingress and egress of guests to prevent unauthorized or unintended intrusions into protected areas.

Chapter 14 Museums, Libraries, and Their Collections

14.1 General.

14.1.1 The requirements of Chapters 1 through 13 shall apply to all museums and libraries.

14.1.2 This chapter shall apply to buildings, rooms, or spaces within buildings that store or display museum collections, buildings, or spaces within buildings that provide storage for library collections available to the public or community served by the library, and historic buildings exhibited or used as museums or that have library collections and readings rooms serving the public.

14.1.3 Library and museum collections that are privately owned and are not open to the public shall not be required to meet the requirements of this code.

14.1.4* This chapter shall supplement existing codes and standards to apply specifically to buildings or portions of buildings devoted to museum or library use.

14.1.5 New construction, addition, alteration, renovation, and modification projects shall comply with the requirements of Chapter 9.

14.1.6* Planning. The governing body of the museum or library shall be responsible for developing and implementing the protection plan in accordance with Chapter 6.

14.1.7 Special Exhibits. When special exhibits are expected to draw large crowds, controls shall be established to ensure that lines and assembly or waiting areas, whether inside or outside of the facility, do not impair evacuation capabilities or emergency access; to limit the number of visitors in each area within the facility to the posted maximum occupancy; and to maintain the security of collections.

14.2 Fire Prevention.

14.2.1 Drapes, Curtains, and Props. Drapes, curtains, props, and similar decorations shall be noncombustible or shall be treated with a listed, approved fire retardant in accordance with the manufacturer's recommendations.

14.2.2 Fire-Retardant Treatments.

14.2.2.1 The fire safety manager shall maintain records of all chemical fire-retardant treatments.

14.2.2.2 Records of fire-retardant treatments shall include the certificate of approval for each fire-retardant coating used, application method, and retreatment schedule.

14.2.3 Decorative Materials. Decorative materials used for special occasions and holidays shall be used in accordance with Section 11.2.

14.2.4* Housekeeping. Housekeeping shall be maintained as required by Section 11.4.

14.2.4.1 Shipping and receiving areas shall be kept clear of accumulated combustible packing and crating materials.

14.2.4.2 Discarded packing materials shall be disposed of daily in accordance with 11.4.8 through 11.4.9.

14.2.5* Precautions shall be kept in place to minimize and control fire hazards in conservation laboratories and studios, restoration, cleaning, and treatment areas, and exhibit construction and fabrication areas.

14.2.6 Hot Work and Open Flames.

14.2.6.1 Hot work operations shall comply with the requirements of Section 11.6.

14.2.6.2 Open flame demonstrations shall be in accordance with Section 11.7.

14.2.7 Flammable and Combustible Liquids.

14.2.7.1 Flammable and combustible liquids, including but not limited to paints, pesticides, and solvents used in conservation areas, shall be stored in accordance with NFPA 30.

14.2.7.2 Cabinets or rooms for the storage or dispensing of flammable liquids shall comply with the requirements of NFPA 30.

14.2.7.3 Listed safety containers shall be provided for the storage and use of flammable and combustible liquids.

14.2.7.4 No more than a 1-day supply of flammable or combustible liquids shall be kept in the building except in an approved storage cabinet or room.

14.2.7.5 Flammable or combustible pesticides used to rid collection objects of insects or mold infestations shall be stored, handled, and used in accordance with the provisions of NFPA 30.

14.2.8 Hazardous Areas.

14.2.8.1* Paint spraying and spray booths shall comply with NFPA 33.

14.2.8.2* Laboratories shall comply with NFPA 45.

14.2.8.3 Print Shops and Binderies. Low flash point inks, blanket wash solutions, and adhesives shall be used and stored in compliance with NFPA 30.

14.2.9 Appliances.

14.2.9.1 Hot plates and other heat-producing appliances shall be listed for their application.

14.2.9.2 Hot plates and other heat-producing appliances shall be maintained in accordance with the manufacturer's instructions.

14.2.9.3 Pilot lights at wall switches or on the appliances shall be provided to indicate visually that the appliance is energized.

14.2.10 Waste receptacles shall be self-closing metal containers.

14.3* Security. Controls shall be implemented and maintained to prevent intentional or inadvertent intrusions from public areas into protected areas.

14.3.1 The installation of an electronic premises security system shall be in accordance with 8.3.4.

14.3.2 Physical security devices shall be installed in accordance with 8.3.5.

14.4 Collection Storage Rooms.

14.4.1* Fire Prevention.

14.4.1.1* Smoking shall be prohibited in all collection storage rooms.

14.4.1.2* Fixed space heaters installed in accordance with the listing and approved by the authority having jurisdiction shall be permitted in collection storage rooms.

14.4.1.3 Portable space heaters shall not be permitted except where the building contents have been removed and the building turned over to the contractor for a construction, renovation, or modification project.

14.4.1.4* Combustible storage containers and supplies shall be kept a minimum of 1 m (36 in.) from potential sources of ignition.

14.4.1.5 Housekeeping. Housekeeping shall be maintained as required by Section 11.4.

14.4.2* Where compact storage is installed in an existing storage area, the existing automatic fire detection and fire suppression systems shall be modified as required to accommodate the increased fire loading.

14.4.3 Security.

14.4.3.1 Access to collection storage areas shall be limited to personnel authorized in the approved security component of the protection plan.

14.4.3.2 Keys to collections storage areas shall only be issued to those staff members who are authorized to have access to collection storage areas in the approved security component of the protection plan.

14.4.3.3 Visitors shall not be allowed access to collections storage areas except when escorted by a staff member authorized in the approved security component of the protection plan to escort visitors into collections storage.

14.4.4 Hazardous Materials.

14.4.4.1* Cellulose Nitrate Film. Storage and handling of cellulose nitrate motion picture film shall comply with the requirements of NFPA 40.

14.4.4.2 Pyroxylin Plastic. Storage of materials or media containing pyroxylin plastic shall comply with NFPA 42.

14.4.4.3 Wet Collections.

14.4.4.3.1* Storage of collections preserved in combustible or flammable petrochemicals shall comply with the requirements of NFPA 30.

14.4.4.3.2 Containers used for storing specimens in combustible, flammable, or toxic liquids shall have tight-sealing lids that minimize evaporation loss or spillage of contents should the container tip over.

14.4.4.3.3 Only approved containers shall be used in dispensing and topping off operations.

14.4.4.3.4 Carts used to transport storage containers shall be sturdy and designed to carry their loads close to the ground.

14.4.5* Storage of Records. Collection accession and other vital records and archival materials shall be stored and protected in accordance with NFPA 232.

14.4.6 Electronic Media.

14.4.6.1 Concealed spaces, combustible electric cable insulation, and storage of paper and records associated with electronic data processing equipment shall comply with the requirements of NFPA 75.

14.4.6.2 Storage of Video, Audio Tapes, and Computer Media. Bulk storage of video, audio, and computer tapes greater than 500 standard VHS tapes or the equivalent shall meet the following requirements:

- (1) Tapes shall be stored in metal storage cabinets in rooms with a minimum 1-hour fire resistance rating.
- (2) Automatic smoke detection shall be provided in the storage room.

14.4.7* Book Stacks.

14.4.7.1 The fire load within a fire compartment containing a multi-tier book stack shall be determined by combining the fuel loading of all levels or tiers in the multi-tier book stack enclosed by the fire compartment.

14.4.7.2 Storage on floor-to-ceiling shelving in multi-tier book stacks shall be permitted where a sprinkler system, designed in accordance with the requirements for this occupancy in NFPA 13 is installed.

Chapter 15 Places of Worship

15.1 General.

15.1.1 The requirements of Chapters 1 through 13 shall apply to buildings used as places of worship.

15.1.2* This chapter shall supplement existing codes and standards and shall apply specifically to buildings, parts of buildings, or enclosed structures that function as a place of worship.

15.1.3 Protection of areas within or associated with a place of worship that function as a museum to display or store artifacts and areas functioning as libraries, book storage, or document storage shall conform to Chapter 14.

15.1.4 New construction, addition, alteration, renovation, and modification projects shall comply with the requirements of Chapter 9.

15.2 Responsibility. The governing body and leadership of the place of worship shall be responsible for the development and implementation of a fire safety program in accordance with Chapter 7 and a security program in accordance with Chapter 8.

15.3 Protection Plan.

15.3.1 The governing body of the place of worship shall be responsible for conducting a vulnerability assessment as required in 5.2.3.

15.3.2* Based on the vulnerability assessment required in 15.3.1, the governing body shall develop a protection plan for the facility in accordance with Chapter 5.

15.3.3 The protection plan shall be readily accessible to the fire department and shall include provisions for the following:

- (1) Notifying the appropriate emergency response agency and directing first responders to the location of the incident
- (2) Posting emergency telephone numbers on or adjacent to all telephones
- (3)* Developing evacuation procedures for all areas to include occupants that require special evacuation assistance

- (4) Identifying historical records such as marriage, birth, and baptismal certificates, valuable artifacts, and relics of special significance and providing for their removal, salvage, or both
- (5) Developing a security program to accomplish the goals and objectives in accordance with Sections 4.2 and 4.3

15.4 Occupant Loading. When special services, programs, commemorations, exhibits, or holidays are expected to draw large crowds, controls shall be established to ensure that lines and assembly or waiting areas, whether inside or outside of the place of worship, do not impair evacuation capabilities or emergency access; to limit the number of visitors in each area within the facility to the posted maximum occupancy; and to maintain the security of the contents.

15.5 Training.

15.5.1 All staff and employees of the place of worship and key volunteers shall be trained in the provisions of the emergency evacuation procedures in the protection plan and the fire department notification procedures.

15.5.2 Training shall include damage limitation procedures for items of cultural significance.

15.6 Fire Prevention.

15.6.1 Draperies and Decorations.

15.6.1.1 All combustible draperies and decorations shall be treated with a fire-retardant compound.

15.6.1.2 Fire-retardant treatment of religious and historically significant fabrics shall not be required where such treatment will cause damage to the fabric. This provision shall apply only on an object-by-object basis and where alternate protection measures are approved.

15.6.1.3 Decorations and draperies shall be kept a minimum of 1 m (36 in.) from ignition sources, including candles, censers, light fixtures, radiators, and electric heaters.

15.6.1.4 Decorative materials used for special occasions and holidays shall be noncombustible or shall be treated with a listed and approved fire retardant.

15.6.2* Housekeeping. Housekeeping practices in accordance with Section 11.4 shall be maintained.

15.6.2.1 Concealed spaces in the attic, basement, organ pipe runs, steeples, and beneath stairs and raised altar areas shall be kept free from accumulations of combustible materials.

15.6.2.2 Flammable liquids such as paints, varnishes, cleaning solvents, and floor polishes shall be stored inside an approved flammable liquids storage cabinet.

15.6.2.3 Quantities of flammable liquids stored inside the building shall be stored and used in compliance with NFPA 30.

15.6.2.4 Approved, self-closing trash containers shall be used to house oily rags.

15.6.2.5 Trash disposal shall be performed regularly.

15.6.2.6 Power lawn mowers, snow blowers, and other gas-powered implements shall not be stored within the structure.

15.7 Fire Protection Systems. Fire suppression and detection systems shall be incorporated in all existing construction in

accordance with the governing body's fire safety goals and objectives.

15.8 Candles and Censers. The use of all open flame devices shall comply with the applicable life safety and fire prevention code.

15.8.1 All lit candles shall be maintained a minimum of 1 m (36 in.) from combustible draperies and hangings.

15.8.2 All fixed candles shall be supported to prevent them from tipping over.

15.8.3 Following the extinguishment of all candles and incense fires, an individual shall remain on the premises for 30 minutes to guard against potential reignition.

15.8.4 Incense fires in censers shall be extinguished after use and before the censers are stored.

15.9 Historical Records and Artifacts. Valuable record storage shall be protected in accordance with NFPA 232.

15.10 Special Facilities.

15.10.1 Kitchens.

15.10.1.1 Kitchen Maintenance.

15.10.1.1.1 Kitchens shall be maintained in a clean and orderly manner.

15.10.1.1.2 Surfaces and equipment shall be kept free of grease, and food wastes shall be disposed of promptly.

15.10.1.1.3 Means of egress from kitchens shall be maintained free of trash containers and other materials.

15.10.1.2 Residential Cooking Appliances.

15.10.1.2.1 Listed residential cooking appliances shall be permitted in kitchens and shall be installed and maintained in accordance with their listings.

15.10.1.2.2 Residential cooking appliances in kitchens that are not used for commercial cooking and are ancillary to the operation of the place of worship, and where cooking does not produce grease-laden vapors, shall be provided with a listed household/consumer hood.

15.10.1.3 Commercial Cooking Appliances. Listed commercial cooking appliances shall be provided with a hood and exhaust system, grease removal devices, auxiliary equipment, and fire-extinguishing equipment in compliance with NFPA 96.

15.10.1.3.1 Equipment shall be used, inspected, and maintained in compliance with NFPA 96.

15.10.1.3.2 Only nonflammable cleaners shall be used.

15.10.2 Schools.

15.10.2.1 Preschool or nursery school facilities located in a place of worship shall comply with the applicable building code, fire code, or life safety code.

15.10.2.2 The governing body shall consult the local authority having jurisdiction prior to establishing a school in their building.

15.10.3* Homeless Shelters.

15.10.3.1 Sleeping rooms for the homeless shall comply with the applicable building code, fire code, or life safety code.

15.10.3.2 The governing body shall consult the local authority having jurisdiction prior to adding sleeping facilities to a place of worship.

15.10.3.3* Measures and procedures shall be put in place to limit access of homeless clients to non-shelter areas of the building.

15.10.4* **Sanctuaries, Auditoriums, and Gymnasiums.** Sanctuaries, auditoriums, and gymnasiums shall comply with the applicable building code, fire code, or life safety code.

15.10.5 Libraries. Libraries shall be protected in accordance with Chapter 14.

15.10.6 Artifacts and Museum/Exhibit Areas. Museum areas, including artifact and exhibit areas, shall be protected in accordance with Chapter 14.

Annex A Explanatory Material

Annex A is not a part of the requirements of this NFPA document but is included for informational purposes only. This annex contains explanatory material, numbered to correspond with the applicable text paragraphs.

A.1.1.3 Cultural resource properties should comply with the provisions of NFPA 101.

A.1.2 Examples of physical conditions or situations that have potential to cause damage or loss to property, collections, or operations include, but are not limited to, fire, flood, hurricane, or vandalism.

A.1.3 Such structures include, but are not limited to, buildings that store or display museum or library collections, historic structures, and places of worship. These structures also include spaces within other buildings used for such culturally significant purposes.

A.1.3.2.2(1) An example of such a change would be the conversion of an office area into collections storage or exhibition space.

A.1.3.2.2(4) Examples of such modifications would include the addition of a high-value or highly vulnerable item to the collection, a high-profile special event, a controversial exhibit with the potential for violence, or the addition of collections that are vulnerable to severe weather, vandalism, or other threats, such as a new outdoor sculpture garden, changes in storage configuration, or the addition of compact mobile shelving.

A.1.4.1 This code is intended to be available for adoption or use internationally. Even in jurisdictions within the United States, other standards might have been adopted in lieu of certain NFPA publications referred to herein. In accordance with 1.4.1, nothing in this code would prohibit regulated parties from making use of alternative standards or codes that are approved by the authority having jurisdiction.

A.1.6 The governing authority, as referenced in Section 1.6, is not intended to exclude the governing body, as defined in 3.3.35.

A.3.2.1 Approved. The National Fire Protection Association does not approve, inspect, or certify any installations, procedures, equipment, or materials; nor does it approve or evaluate testing laboratories. In determining the acceptability of installa-

tions, procedures, equipment, or materials, the authority having jurisdiction may base acceptance on compliance with NFPA or other appropriate standards. In the absence of such standards, said authority may require evidence of proper installation, procedure, or use. The authority having jurisdiction may also refer to the listings or labeling practices of an organization that is concerned with product evaluations and is thus in a position to determine compliance with appropriate standards for the current production of listed items.

A.3.2.2 Authority Having Jurisdiction (AHJ). The phrase “authority having jurisdiction,” or its acronym AHJ, is used in NFPA documents in a broad manner, since jurisdictions and approval agencies vary, as do their responsibilities. Where public safety is primary, the authority having jurisdiction may be a federal, state, local, or other regional department or individual such as a fire chief; fire marshal; chief of a fire prevention bureau, labor department, or health department; building official; electrical inspector; or others having statutory authority. For insurance purposes, an insurance inspection department, rating bureau, or other insurance company representative may be the authority having jurisdiction. In many circumstances, the property owner or his or her designated agent assumes the role of the authority having jurisdiction; at government installations, the commanding officer or departmental official may be the authority having jurisdiction.

A.3.2.3 Code. The decision to designate a standard as a “code” is based on such factors as the size and scope of the document, its intended use and form of adoption, and whether it contains substantial enforcement and administrative provisions.

A.3.2.4 Listed. The means for identifying listed equipment may vary for each organization concerned with product evaluation; some organizations do not recognize equipment as listed unless it is also labeled. The authority having jurisdiction should utilize the system employed by the listing organization to identify a listed product.

A.3.3.6.1 Multi-Tier Book Stack. The system is usually erected inside a structural shell housing the book stack. Typically a vertical opening (space gap or “deck-slit”) is present between the walkway and the ranges at each tier from the bottom tier to the top tier. [See Figure A.9.12.24.8(a) and Figure A.9.12.24.8(b).]

A.3.3.7 Buildings. The term building is construed as if followed by the words “or portion thereof.” A historic building is one designated by a local, regional, or national, or international jurisdiction as having historic, architectural, or cultural significance. Designation could be in an official existing or future international, national, regional, or local historic register, listing, or inventory. Properties that meet the criteria for eligibility should be treated as eligible. This also includes buildings in historic districts that are not architecturally distinguished, but whose scale, proportions, materials, and details are consistent with the character of the district.

A.3.3.17 Cultural Resource Properties. Such properties include, but are not limited to, museums, libraries, historic structures, and places of worship.

A.3.3.29 Fire Retardant. Chemical fire retardants improve reaction to fire or fire-resistance properties of treated materials, such as delaying ignition or lowering the heat release rate. On a wood building element, such as a wall, partition, column,

or other material, a fire-retardant treatment reduces the flame spread index and/or the smoke developed index.

A.3.3.30 Fire Safety Manager. In smaller organizations, this role can be combined with that of another position or appointment. In larger cultural resource properties, the person's responsibilities should be permitted to include supervision of other fire protection staff. The authorized person should be an employee of the cultural resource facility who has certification, education, training, and/or experience with generally accepted fire protection practices. Alternatively, cultural resource properties should be permitted to designate appropriate outside persons such as consulting fire protection engineers, fire service personnel, insurance company loss control representatives, local code officials, or other individuals with similar fire protection credentials.

A.3.3.37 Hazardous Area. Examples include the following:

- (1) Storage or use of combustibles or flammables
- (2) Storage or use of toxic, noxious, or corrosive materials
- (3) Use of heat-producing appliances

A.3.3.39 Historic Structure. Examples listed (i.e., buildings, bridges, lighthouses, monuments) are from "How to Define Categories of Historic Properties," *National Register Bulletin 15, How to Apply the National Register Criteria for Evaluation*.

A.3.3.41 Impairment. An impairment is a system component or function that is not working properly, which can result in the system or unit not functioning when required. This might be due to an intentional act, such as closing a valve or disabling an initiating device. The impairment also might be caused by a deficiency in a piece of equipment or subsystem. An example of emergency impairment is physical damage to a control unit or wiring. Examples of a planned impairment include the addition of new devices or appliances or the reprogramming of system software. [72, 2016]

A.3.3.42 Incendiary Fire. Arson fires are incendiary fires.

A.3.3.45 Library. The term *library* covers an extremely wide range of situations; a library can be a small special or valuable collection in a private home or other building, or it can be a separate section in a building used for many purposes. It can also be a multi-million dollar complex of buildings, the purpose of which is to provide not only storage of books, but also study and reading areas, catalog rooms, work rooms, binderies, art collections, shops, and places of public assembly. However, all libraries have one characteristic in common: ample fuel in the form of books and other library materials, which can include compact discs, microforms, magnetic tapes, phonograph records, and motion picture films — cellulose nitrate, that can burn and contribute to a serious fire, as well as safety film.

A.3.3.47 Management Operational Systems. Where cultural resource properties have trained staff, the institution can take advantage of that resource as an element in the overall fire protection program. Management involvement and a trained staff play a vital role in a comprehensive protection program, and training and management oversight can eliminate many common factors that contribute to fire or security incidents. For example, should a fire occur, trained staff, using portable fire extinguishers, might be able to suppress the fire before it threatens culturally significant collections. After a fire, a trained and appropriately equipped staff with an effective

damage limitation procedures can mitigate damage to threatened objects.

A.3.3.50 Museum. The American Association of Museums defines a museum as an organized and permanent nonprofit institution essentially educational or aesthetic in purpose, with professional staff, which owns and uses tangible objects, cares for them, and exhibits them to the public on some regular schedule.

A.3.3.74.2 Fire Scenario. A fire scenario defines the conditions under which a proposed design is expected to meet the fire safety goals. Factors typically include fuel characteristics, ignition sources, ventilation, building characteristics, and occupant locations and characteristics. Fire scenarios include more than the characteristics of the fire itself but exclude design specifications and any characteristics that do not vary from one fire to another; the later are called assumptions. The term fire scenario is used here to mean only those specifications required to calculate the fire's development and effects, but in other contexts, the term can be used to mean both the initial specifications and the subsequent development and effects (i.e., a complete description of fire from conditions prior to ignition to conditions following extinguishment).

A.3.3.79 Special Event. Special events include receptions, dinners, private viewings, filming operations, and similar activities held at the cultural resource property for specific groups (e.g., members, boards, outside organizations).

A.3.3.84 Utilities. Utilities can include lighting and electrical power services; telecommunication and security services; electrical control circuits; HVAC distribution and control circuits and duct systems; water, steam, waste water, and drain pipes and services; fire suppression systems, including water-based and non-water-based; oil, gas, hydraulic, and pneumatic systems; and any other electrical or mechanical building services.

A.4.3 See NFPA 550 for a method to determine fire protection objectives.

A.5.1 Chapter 5 is intended to aid in developing, maintaining, and evaluating effective protection and emergency management programs. For additional information on emergency management programs, see *NFPA 1600*.

A.5.1.1 This chapter provides the governing body of a cultural resource property with a framework to develop a protection plan.

A.5.2.3 An important part of a vulnerability assessment is a risk analysis, a careful examination of what could cause harm to people the environment, property, collections, or the cultural resource property's continuity of operations objectives so the governing body can identify whether adequate precautions have been taken or more should be done to prevent damage or loss. There are many websites and documents (such as NFPA 730) that discuss vulnerability and risk principles and how to apply them to specific situations. Vulnerability assessment and risk analysis includes the following activities:

- (1) Defining assessment scope
- (2) Identifying the potential threats and/or loss scenarios
- (3) Determining who or what might be harmed and how
- (4) Evaluating the risks through estimation of the likelihood of occurrence and the severity of the consequences
- (5) Determining risk tolerability

- (6) Managing risk — deciding on measures to eliminate, prevent, or mitigate the risks
- (7) Documenting findings and implementing them based on cost considerations
- (8) Reviewing and updating risk assessments based on changes or new information

Conditions in the cultural resource property change over time, and these changes can increase or decrease the vulnerability of the facility and/or the collection to potential threats. Construction projects, new exhibits, a traveling exhibit, or a new item in the collection can have a significant impact on the vulnerability assessment, so it is important for the governing body to review the vulnerability assessment regularly, and when planning construction, renovation, modifications, alternations, special events, or changes in exhibits.

Some cultural resource properties might find the process described in this chapter to be overwhelming. It need not be so. People and institutions use the process of risk analysis in decision making every day. The objective of the vulnerability assessment is to identify the most likely ways the cultural resource property might suffer loss or damage to its facilities and collections and, with this information, to develop realistic ways for the institution to prevent or mitigate potential losses or damage. Figure A.5.2.3 is a survey checklist that can be used to conduct a basic vulnerability assessment. Many cultural resource properties will find that the survey is too simplistic, but it does provide a sample of a method that can serve as the basis for a more thorough assessment.

A.5.2.4 Before conducting the assessment, metrics should be established that allow documentation of the vulnerability assessment results in a way that facilitates decision making. Results can be either relative (e.g., compared to a baseline or comparing alternative options) or absolute (e.g., dollar losses per year). Within this context, they can be qualitative, quantitative, or semi-quantitative and can be in the form of a quantitative risk value, a comparative value, or other values as established by the governing body. The form of the acceptable criteria should be dependent on the defined scope of the assessment and should influence the selection of assessment methods. Acceptance criteria can be based on one of the following:

- (1) Prescriptive requirements
- (2) Performance requirements
- (3) Other agreed-to criteria
- (4) Professional standards and guides of the cultural resources community

A.5.2.8 Where the cultural resource property staff does not have an expertise in a particular area of protection, the governing body can contract with qualified fire protection professionals, security professionals, or both.

A.5.3.2.2 An ad hoc planning team that should be interdisciplinary in nature, representing security, safety, and preservation concerns, should be assembled to develop the protection plan for the cultural resource property. Early consultation and coordination at each step of the process is highly desirable and strongly recommended. While every effort should be made to create an interdisciplinary team of players, the code recognizes that there will be times when such a diversity of members is not possible. The code, therefore, suggests but does not require any particular membership of the team. Participants on the team can include the following:

- (1) Design professionals

- (2) Fire protection and/or security consultants
- (3) Authorities having jurisdiction, including the following:
 - (a) Preservation officers or review agency
 - (b) Fire code officials
 - (c) Building code official or permitting authority
 - (d) Insurance company representative/broker
- (4) Contractor
- (5) Building manager
- (6) Fire safety manager
- (7) Building occupants
- (8) Building owner
- (9) Security manager
- (10) Law enforcement representative (local, state, and/or federal)
- (11) Local emergency planning/response representatives

A.5.3.3.2 The survey is intended to identify the relevant culturally significant elements, spaces, contents, and features and relevant protection issues associated with the structure. The extent and depth of the survey might vary, depending upon the cultural significance of the building and its component elements, the size and complexity of the building, changes of occupancy classification, and other factors as appropriate.

A.5.3.3.2.1.1 Character-defining features include, but are not limited to, sheathing or façade materials, roofing materials, chimneys, skylights, cornices, windows and doors, and porches and railings.

A.5.3.3.2.1.2 Character-defining features and finishes include, but are not limited to, distinctive architectural details, wainscoting, parquet flooring, picture molding, mantels, ceiling medallions, built-in bookshelves and cabinets, crown molding and arches, as well as simpler, more utilitarian features such as plain windows and doors, and associated trim. The building survey should identify important characteristics of the building type, style, period, or historic function. The building survey should include significant spaces to identify rooms or other interior locations that are typical of the building type or style or are associated with specific persons or events.

A.5.3.5 Figure 5.3.5.2 can be used to identify applicable potential threats.

A.5.3.6 The *Likelihood of Occurrence and Potential Severity* sections found in Figure 5.3.5.2 can be used to evaluate potential threats. For example, an institution might decide that a potential threat such as heavy snow loading on the roof is tolerable due to the physical characteristics of the roof.

A.5.3.7 The analysis of loss scenarios should consider secondary threats resulting from the initial threat. For example, the potential threat of an earthquake can produce secondary threats such as fire, building collapse, water damage, and so forth.

A.6.1.1 The emergency management planning committee should be a multidiscipline group that includes representatives from all the major stakeholders in the cultural resource property. Depending on the complexity of the cultural resource property, stakeholders could include administration, curators, conservators, building maintenance personnel, security and fire personnel, and others with special areas of interest or expertise.

VULNERABILITY ASSESSMENT SURVEY

1. Construction

- a. Building: Fire resistive Noncombustible Combustible
(See NFPA 220, Standard on Types of Building Construction)
- b. Date of construction: _____ Historic building? No Yes
- c. Culturally/historically significant building features: _____
- d. Roof: Combustible Noncombustible Type: _____
- e. Is the building under construction, renovation, or modification? No Yes

2. Size

- Floor area _____
- Number of floors _____
- Number of connecting building or wings _____
- Number of entrances _____
- Number of emergency exits _____
- Number of exit width units available (see applicable building or life safety code) _____
- Number of exit width units required by the applicable building or life safety code _____
- Number of employees _____
- Number of visitors per day _____
- Average _____
- Maximum _____

3. Exposure Fire Risk

Direction	N/A	Low	Moderate	High
North	<input type="checkbox"/>	<input type="checkbox"/>	<input type="checkbox"/>	<input type="checkbox"/>
West	<input type="checkbox"/>	<input type="checkbox"/>	<input type="checkbox"/>	<input type="checkbox"/>
South	<input type="checkbox"/>	<input type="checkbox"/>	<input type="checkbox"/>	<input type="checkbox"/>
East	<input type="checkbox"/>	<input type="checkbox"/>	<input type="checkbox"/>	<input type="checkbox"/>

4. Water Supply

- Municipal system Reservoir/pond Storage tanks
- Capacity _____
- Size of water mains _____
- Distance from hydrant _____

5. Emergency Services

Fire Service

- Municipal paid fire department Volunteer fire department Facility fire brigade
- Time required for fire service to reach building _____

EMS

- Municipal paid department Volunteer department Employees trained as first responders
- Time required for EMS to reach building _____

Police

- Police department Sheriff's department Other
- Time required for police to reach building _____

Security Officers

- Proprietary Contract Volunteers None
- 24-hour coverage? Yes No If no, hours of coverage: From _____ To _____

FIGURE A.5.2.3 Vulnerability Assessment Survey.

6. Fire Protection		Yes	No	Partial			
Standpipe system		<input type="checkbox"/>	<input type="checkbox"/>	<input type="checkbox"/>			
Sprinkler system		<input type="checkbox"/>	<input type="checkbox"/>	<input type="checkbox"/>			
Inert gas extinguishing system		<input type="checkbox"/>	<input type="checkbox"/>	<input type="checkbox"/>			
Range hood/duct suppression system		<input type="checkbox"/>	<input type="checkbox"/>	<input type="checkbox"/>			
Water mist system		<input type="checkbox"/>	<input type="checkbox"/>	<input type="checkbox"/>			
Fire extinguishers		<input type="checkbox"/>	<input type="checkbox"/>	<input type="checkbox"/>			
Types: _____							
Locations: _____							
Automatic fire detection system		<input type="checkbox"/>	<input type="checkbox"/>	<input type="checkbox"/>			
Local fire alarm system		<input type="checkbox"/>	<input type="checkbox"/>	<input type="checkbox"/>			
Direct alarm to fire service or central station		<input type="checkbox"/>	<input type="checkbox"/>	<input type="checkbox"/>			
Central station listed by Underwriter's Laboratories		<input type="checkbox"/>	<input type="checkbox"/>	<input type="checkbox"/>			
Fire walls and self-closing fire doors protecting horizontal openings between building units		<input type="checkbox"/>	<input type="checkbox"/>	<input type="checkbox"/>			
Furnace room separated from rest of building by fire walls and self-closing fire doors		<input type="checkbox"/>	<input type="checkbox"/>	<input type="checkbox"/>			
Fire resistance rated enclosures protecting stairways and other vertical openings		<input type="checkbox"/>	<input type="checkbox"/>	<input type="checkbox"/>			
Exit doors opening outward		<input type="checkbox"/>	<input type="checkbox"/>	<input type="checkbox"/>			
Locked exit doors equipped with panic hardware		<input type="checkbox"/>	<input type="checkbox"/>	<input type="checkbox"/>			
Is there a designated fire manager		<input type="checkbox"/>	<input type="checkbox"/>	<input type="checkbox"/>			
List any changes in character of buildings, occupancy, water supply or hydrants, accessibility, or other general conditions affecting fire safety since the previous survey:							

7. Security		Yes	No	Partial			
Premises protection system		<input type="checkbox"/>	<input type="checkbox"/>	<input type="checkbox"/>			
CCTV system		<input type="checkbox"/>	<input type="checkbox"/>	<input type="checkbox"/>			
Card access system		<input type="checkbox"/>	<input type="checkbox"/>	<input type="checkbox"/>			
Fence		<input type="checkbox"/>	<input type="checkbox"/>	<input type="checkbox"/>			
Local premises protection alarm system		<input type="checkbox"/>	<input type="checkbox"/>	<input type="checkbox"/>			
Direct alarm to police or central station		<input type="checkbox"/>	<input type="checkbox"/>	<input type="checkbox"/>			
Central station listed by Underwriter's Laboratories		<input type="checkbox"/>	<input type="checkbox"/>	<input type="checkbox"/>			
Is there a designated security manager		<input type="checkbox"/>	<input type="checkbox"/>	<input type="checkbox"/>			
List any changes in character of buildings, occupancy, collections, accessibility, or other general conditions affecting security of the cultural resource property since the previous survey:							

8. Collections		Vulnerability to Water Damage			Emergency Off-Site Storage Available?		
Type	Location	High	Moderate	Low	Yes	No	Location
_____	_____	<input type="checkbox"/>	<input type="checkbox"/>	<input type="checkbox"/>	<input type="checkbox"/>	<input type="checkbox"/>	_____
_____	_____	<input type="checkbox"/>	<input type="checkbox"/>	<input type="checkbox"/>	<input type="checkbox"/>	<input type="checkbox"/>	_____
_____	_____	<input type="checkbox"/>	<input type="checkbox"/>	<input type="checkbox"/>	<input type="checkbox"/>	<input type="checkbox"/>	_____
_____	_____	<input type="checkbox"/>	<input type="checkbox"/>	<input type="checkbox"/>	<input type="checkbox"/>	<input type="checkbox"/>	_____
9. Known locations/sources of water intrusion into the building							

FIGURE A.5.2.3 Continued

10. Crime Rate: Low Moderate High

11. Potential Threats

	N/A	Likelihood of Occurrence			Potential Severity		
		Low	Moderate	High	Low	Moderate	High
Unintentional Act							
Fire/explosion	<input type="checkbox"/>	<input type="checkbox"/>	<input type="checkbox"/>	<input type="checkbox"/>	<input type="checkbox"/>	<input type="checkbox"/>	<input type="checkbox"/>
Health emergency	<input type="checkbox"/>	<input type="checkbox"/>	<input type="checkbox"/>	<input type="checkbox"/>	<input type="checkbox"/>	<input type="checkbox"/>	<input type="checkbox"/>
Hazardous material spill or release	<input type="checkbox"/>	<input type="checkbox"/>	<input type="checkbox"/>	<input type="checkbox"/>	<input type="checkbox"/>	<input type="checkbox"/>	<input type="checkbox"/>
Transportation accident	<input type="checkbox"/>	<input type="checkbox"/>	<input type="checkbox"/>	<input type="checkbox"/>	<input type="checkbox"/>	<input type="checkbox"/>	<input type="checkbox"/>
Intentional Act							
Terrorism	<input type="checkbox"/>	<input type="checkbox"/>	<input type="checkbox"/>	<input type="checkbox"/>	<input type="checkbox"/>	<input type="checkbox"/>	<input type="checkbox"/>
Cyber attack	<input type="checkbox"/>	<input type="checkbox"/>	<input type="checkbox"/>	<input type="checkbox"/>	<input type="checkbox"/>	<input type="checkbox"/>	<input type="checkbox"/>
Arson	<input type="checkbox"/>	<input type="checkbox"/>	<input type="checkbox"/>	<input type="checkbox"/>	<input type="checkbox"/>	<input type="checkbox"/>	<input type="checkbox"/>
Theft	<input type="checkbox"/>	<input type="checkbox"/>	<input type="checkbox"/>	<input type="checkbox"/>	<input type="checkbox"/>	<input type="checkbox"/>	<input type="checkbox"/>
Vandalism	<input type="checkbox"/>	<input type="checkbox"/>	<input type="checkbox"/>	<input type="checkbox"/>	<input type="checkbox"/>	<input type="checkbox"/>	<input type="checkbox"/>
Sabotage	<input type="checkbox"/>	<input type="checkbox"/>	<input type="checkbox"/>	<input type="checkbox"/>	<input type="checkbox"/>	<input type="checkbox"/>	<input type="checkbox"/>
Civil disturbance, public unrest, mass hysteria, riot	<input type="checkbox"/>	<input type="checkbox"/>	<input type="checkbox"/>	<input type="checkbox"/>	<input type="checkbox"/>	<input type="checkbox"/>	<input type="checkbox"/>
Strike	<input type="checkbox"/>	<input type="checkbox"/>	<input type="checkbox"/>	<input type="checkbox"/>	<input type="checkbox"/>	<input type="checkbox"/>	<input type="checkbox"/>
System Failure							
Loss of electricity	<input type="checkbox"/>	<input type="checkbox"/>	<input type="checkbox"/>	<input type="checkbox"/>	<input type="checkbox"/>	<input type="checkbox"/>	<input type="checkbox"/>
Water leak	<input type="checkbox"/>	<input type="checkbox"/>	<input type="checkbox"/>	<input type="checkbox"/>	<input type="checkbox"/>	<input type="checkbox"/>	<input type="checkbox"/>
Building collapse/structural failure	<input type="checkbox"/>	<input type="checkbox"/>	<input type="checkbox"/>	<input type="checkbox"/>	<input type="checkbox"/>	<input type="checkbox"/>	<input type="checkbox"/>
Fuel shortage	<input type="checkbox"/>	<input type="checkbox"/>	<input type="checkbox"/>	<input type="checkbox"/>	<input type="checkbox"/>	<input type="checkbox"/>	<input type="checkbox"/>
Communications system interruption	<input type="checkbox"/>	<input type="checkbox"/>	<input type="checkbox"/>	<input type="checkbox"/>	<input type="checkbox"/>	<input type="checkbox"/>	<input type="checkbox"/>
Air/water pollution contamination	<input type="checkbox"/>	<input type="checkbox"/>	<input type="checkbox"/>	<input type="checkbox"/>	<input type="checkbox"/>	<input type="checkbox"/>	<input type="checkbox"/>
Water control structure, dam, or levee failure	<input type="checkbox"/>	<input type="checkbox"/>	<input type="checkbox"/>	<input type="checkbox"/>	<input type="checkbox"/>	<input type="checkbox"/>	<input type="checkbox"/>
HVAC system failure	<input type="checkbox"/>	<input type="checkbox"/>	<input type="checkbox"/>	<input type="checkbox"/>	<input type="checkbox"/>	<input type="checkbox"/>	<input type="checkbox"/>
Loss of protection systems	<input type="checkbox"/>	<input type="checkbox"/>	<input type="checkbox"/>	<input type="checkbox"/>	<input type="checkbox"/>	<input type="checkbox"/>	<input type="checkbox"/>
Geological							
Earthquake	<input type="checkbox"/>	<input type="checkbox"/>	<input type="checkbox"/>	<input type="checkbox"/>	<input type="checkbox"/>	<input type="checkbox"/>	<input type="checkbox"/>
Tsunami	<input type="checkbox"/>	<input type="checkbox"/>	<input type="checkbox"/>	<input type="checkbox"/>	<input type="checkbox"/>	<input type="checkbox"/>	<input type="checkbox"/>
Volcano	<input type="checkbox"/>	<input type="checkbox"/>	<input type="checkbox"/>	<input type="checkbox"/>	<input type="checkbox"/>	<input type="checkbox"/>	<input type="checkbox"/>
Landslide/mudslide	<input type="checkbox"/>	<input type="checkbox"/>	<input type="checkbox"/>	<input type="checkbox"/>	<input type="checkbox"/>	<input type="checkbox"/>	<input type="checkbox"/>
Biological							
Pandemic disease	<input type="checkbox"/>	<input type="checkbox"/>	<input type="checkbox"/>	<input type="checkbox"/>	<input type="checkbox"/>	<input type="checkbox"/>	<input type="checkbox"/>
Animal or insect infestation	<input type="checkbox"/>	<input type="checkbox"/>	<input type="checkbox"/>	<input type="checkbox"/>	<input type="checkbox"/>	<input type="checkbox"/>	<input type="checkbox"/>
Meteorological							
Flood, flash flood, seiche, tidal surge	<input type="checkbox"/>	<input type="checkbox"/>	<input type="checkbox"/>	<input type="checkbox"/>	<input type="checkbox"/>	<input type="checkbox"/>	<input type="checkbox"/>
Drought	<input type="checkbox"/>	<input type="checkbox"/>	<input type="checkbox"/>	<input type="checkbox"/>	<input type="checkbox"/>	<input type="checkbox"/>	<input type="checkbox"/>
Wildland fire (forest, brush, grass, ground)	<input type="checkbox"/>	<input type="checkbox"/>	<input type="checkbox"/>	<input type="checkbox"/>	<input type="checkbox"/>	<input type="checkbox"/>	<input type="checkbox"/>
Snow, ice, hail, sleet, avalanche	<input type="checkbox"/>	<input type="checkbox"/>	<input type="checkbox"/>	<input type="checkbox"/>	<input type="checkbox"/>	<input type="checkbox"/>	<input type="checkbox"/>
Windstorm, tropical cyclone, hurricane, tornado, water spout, dust/sand storm	<input type="checkbox"/>	<input type="checkbox"/>	<input type="checkbox"/>	<input type="checkbox"/>	<input type="checkbox"/>	<input type="checkbox"/>	<input type="checkbox"/>
Extreme heat/cold	<input type="checkbox"/>	<input type="checkbox"/>	<input type="checkbox"/>	<input type="checkbox"/>	<input type="checkbox"/>	<input type="checkbox"/>	<input type="checkbox"/>
Lightning	<input type="checkbox"/>	<input type="checkbox"/>	<input type="checkbox"/>	<input type="checkbox"/>	<input type="checkbox"/>	<input type="checkbox"/>	<input type="checkbox"/>
Other:							
_____	<input type="checkbox"/>	<input type="checkbox"/>	<input type="checkbox"/>	<input type="checkbox"/>	<input type="checkbox"/>	<input type="checkbox"/>	<input type="checkbox"/>
_____	<input type="checkbox"/>	<input type="checkbox"/>	<input type="checkbox"/>	<input type="checkbox"/>	<input type="checkbox"/>	<input type="checkbox"/>	<input type="checkbox"/>

FIGURE A.5.2.3 *Continued*

	Yes	No	N/A		Yes	No	N/A
12. Are there periodic inventories of the collection? <input type="checkbox"/> Full inventories <input type="checkbox"/> Partial inventories Date of last inventory: _____	<input type="checkbox"/>	<input type="checkbox"/>	<input type="checkbox"/>	30. Have staff been trained on when and how to notify the fire and police departments?	<input type="checkbox"/>	<input type="checkbox"/>	<input type="checkbox"/>
13. Do inventory records include basic identifying information for each object in the collection?	<input type="checkbox"/>	<input type="checkbox"/>	<input type="checkbox"/>	31. Are all building occupants trained on procedures for reporting emergencies?	<input type="checkbox"/>	<input type="checkbox"/>	<input type="checkbox"/>
14. Are copies of inventories, insurance records, and other critical records stored off site?	<input type="checkbox"/>	<input type="checkbox"/>	<input type="checkbox"/>	32. Are staff trained to direct and assist emergency response personnel when they arrive?	<input type="checkbox"/>	<input type="checkbox"/>	<input type="checkbox"/>
15. Are collection storage areas inspected routinely?	<input type="checkbox"/>	<input type="checkbox"/>	<input type="checkbox"/>	33. Are there means/methods to maintain continuity of essential building services and systems?	<input type="checkbox"/>	<input type="checkbox"/>	<input type="checkbox"/>
16. Has shelving been evaluated for seismic stability?	<input type="checkbox"/>	<input type="checkbox"/>	<input type="checkbox"/>	34. Have arrangements been made for emergency repairs or restoration of critical building services?	<input type="checkbox"/>	<input type="checkbox"/>	<input type="checkbox"/>
17. Are critical building components, such as roofs, windows, drains, etc., routinely inspected and maintained?	<input type="checkbox"/>	<input type="checkbox"/>	<input type="checkbox"/>	35. Are floor plans showing location of all fire protection equipment, shutoff valves, etc., available for use by emergency personnel?	<input type="checkbox"/>	<input type="checkbox"/>	<input type="checkbox"/>
18. Are measures in place to protect sensitive collections from known water intrusions into the building?	<input type="checkbox"/>	<input type="checkbox"/>	<input type="checkbox"/>	36. Does the facility have a basic emergency response supply kit?	<input type="checkbox"/>	<input type="checkbox"/>	<input type="checkbox"/>
19. Does the emergency operations plan address at least those potential threats with a high likelihood of occurrence and high potential severity?	<input type="checkbox"/>	<input type="checkbox"/>	<input type="checkbox"/>	37. Have emergency shutdown procedures been developed for the building and/or major mechanical and electrical systems?	<input type="checkbox"/>	<input type="checkbox"/>	<input type="checkbox"/>
20. Is the emergency operations plan up-to-date? Last update: _____	<input type="checkbox"/>	<input type="checkbox"/>	<input type="checkbox"/>	38. Have plans been developed to coordinate internal and external resources, such as mutual aid from sister institutions?	<input type="checkbox"/>	<input type="checkbox"/>	<input type="checkbox"/>
21. Does the emergency operations plan clearly assign responsibility?	<input type="checkbox"/>	<input type="checkbox"/>	<input type="checkbox"/>	39. Have procedures been established for emergency evacuation of collections?	<input type="checkbox"/>	<input type="checkbox"/>	<input type="checkbox"/>
22. Is there a clear-cut emergency organization, preferably following existing lines of authority?	<input type="checkbox"/>	<input type="checkbox"/>	<input type="checkbox"/>	40. Does the plan identify off-site storage locations for collections in the event of an evacuation?	<input type="checkbox"/>	<input type="checkbox"/>	<input type="checkbox"/>
23. Are emergency organization members designated by position and not just by name?	<input type="checkbox"/>	<input type="checkbox"/>	<input type="checkbox"/>	41. Have responsibilities been established to ensure a timely evacuation of collections?	<input type="checkbox"/>	<input type="checkbox"/>	<input type="checkbox"/>
24. Do emergency organization members know their responsibilities and who has authority to make decisions in any given situation?	<input type="checkbox"/>	<input type="checkbox"/>	<input type="checkbox"/>	42. Is there a plan to begin damage limitation operations as soon as safety personnel permit?	<input type="checkbox"/>	<input type="checkbox"/>	<input type="checkbox"/>
25. Has the central command center location been established?	<input type="checkbox"/>	<input type="checkbox"/>	<input type="checkbox"/>	43. Does the plan include provisions to assess and document damage to buildings and collections?	<input type="checkbox"/>	<input type="checkbox"/>	<input type="checkbox"/>
26. Are communications systems at the command center adequate?	<input type="checkbox"/>	<input type="checkbox"/>	<input type="checkbox"/>	44. Has the damage limitation plan been reviewed with the fire service?	<input type="checkbox"/>	<input type="checkbox"/>	<input type="checkbox"/>
27. Do emergency organization members know when to report to the command center?	<input type="checkbox"/>	<input type="checkbox"/>	<input type="checkbox"/>	45. Has the emergency operations plan been reviewed with the public safety agencies?	<input type="checkbox"/>	<input type="checkbox"/>	<input type="checkbox"/>
28. Do emergency organization members know what medical resources are available and how to access them?	<input type="checkbox"/>	<input type="checkbox"/>	<input type="checkbox"/>	46. Have drills and training been adequate to ensure a workable emergency plan?	<input type="checkbox"/>	<input type="checkbox"/>	<input type="checkbox"/>
29. Are emergency telephone numbers posted in the command center and throughout the building?	<input type="checkbox"/>	<input type="checkbox"/>	<input type="checkbox"/>				

© 2016 National Fire Protection Association

NFPA 909 (p. 4 of 4)

FIGURE A.5.2.3 *Continued*

A.6.1.2 While most emergency situations are handled locally, when there is a major incident help might be needed from other jurisdictions, the state, and the federal government. The National Incident Management System (NIMS) was developed so responders from different jurisdictions and disciplines can work together to respond to natural disasters and emergencies, including acts of terrorism. NIMS benefits include a unified approach to incident management, standard command and management structures, and emphasis on preparedness, mutual aid, and resource management. See Federal Emergency Management Agency (FEMA) document *National Incident Management System* for more information on NIMS.

A.6.1.3 Examples of the roles and responsibilities of the response and recovery team include, but are not limited to, the following:

- (1) Report on the status of building occupants, including employees and other occupants
- (2) Report on known conditions in the building (i.e., location of fire or other emergency, status of extinguishing systems, location and status of hazardous materials, location and status of high-value contents, and status and location of hazardous or unusual conditions such as ongoing construction, renovation, or modification)
- (3) Coordination and expert guidance on recovery and preservation of contents
- (4) Coordination of dissemination of information to the public
- (5) Management of decisions related to non-fire incidents, such as bomb threats, hazardous materials incidents, and so forth
- (6) Appoint a liaison to the incident commander (command structure)

A.6.6 Section 4.8 of NFPA *101* should be used as a guide in the planning and development of the emergency response.

A.6.6.2 Most fire protection systems activate automatically; however, if automatic features do not exist or are impaired, manual activation means should be identified in the emergency response procedures. Protection systems can include special agent fire suppression systems, smoke control systems, and means to provide compartmentation such as closing doors.

A.6.8.1.1 The cultural resource property should maintain a current inventory of both cataloged and uncataloged collections.

A.6.8.1.3 Published standards for identification such as Object ID standard for museum objects can be found at <http://www.object-id.com/>, or the *Guidelines for the Security of Rare Books, Manuscripts, and Other Special Collections*, Appendix I — Guidelines for Marking Books, Manuscripts, and Other Special Collections at <http://www.ala.org/ala/acrl/acrlstandards/guidelinessecurity.htm>.

A.6.8.2 The vulnerability assessment should include the following steps:

- (1) Assign a level of risk for potential external threats such as flood, hurricane, tornado, seismic event, volcanic activity, fire from external source, bomb/terrorism.
- (2) Assign a level of risk for potential internal threats such as fire, theft/vandalism, security failure, structural failure of building envelope, systems failure (electricity, gas lines, fire suppression, and plumbing), mold, pests.

Those potential threats that present a higher risk consequently place collections at greater vulnerability to damage. Emergency planning within the institution should feature practical measures for protection against the specific potential threats to which the collection is most vulnerable.

Sources of information available in print and on the web to assist institutions in emergency planning for specific potential threats include the following:

Trinkley, Michael. *Hurricane! Surviving the big one: a primer for libraries, museums and archives*, 2nd edition, Columbia, SC: Chicago Foundation; Atlanta, GA: Southeastern Library Network, c1998.

www.fema.gov/hazard/hurricane/index

www.nhc.noaa.gov/HAW2/english/disaster_prevention.shtml

<http://www.nedcc.org/about/news.dplan.php>

A.6.8.2.1 Information from the collection inventory along with visual assessment completed by staff familiar with collection content and storage locations will aid in developing this list.

A.6.8.2.1.2 In order to identify areas of higher vulnerability and develop strategies for protection, it will be useful to map the location of documented material types and formats, particularly those most susceptible to damage, within a general map of collection locations.

A.6.8.2.2 Note any correlation between inherent vulnerability of the institution's infrastructure and the inherent vulnerability to water of the material type on the survey list, especially where risk to materials is elevated due primarily to its storage location. A map of exposed/exterior walls and windows, as well as plumbing routes and HVAC systems will be helpful in identifying potentially vulnerable locations.

A.6.8.2.3 Information is available at the following sites:

<http://quake.wr.usgs.gov/prepare/>

<http://www.fema.gov/areyouready/earthquakes.shtml>

A.6.8.2.4 In particular, an evaluation of relative humidity levels, fire protection plans, and fire detection and suppression systems, and emergency recovery procedures should be completed for subterranean and below-grade storage locations.

A.6.8.2.5 Those responsible for collections should thoroughly understand the effects of water on collections, along with the comparative vulnerability found among material types — that is, risk presented by water damage to paper vs. parchment, soluble media vs. black printer's inks, ceramic vs. bone, CD-ROMs vs. microfiche, and so forth.

Storage furnishings and individual enclosures will reduce the risk of damage from several types of threats. They can provide protection from threats such as dirt, heat, soot and smoke; can repel or resist water for varying amounts of time; and can absorb trauma from collision. Sealed cabinets are examples of risk-reducing furnishings or enclosures.

A.6.8.3.1 Procedures for protecting the collection should include the following:

- (1) Identify staff members, volunteers, conservators, and contractors with specific expertise in the recovery of each material type in the collection.
- (2) Identify additional staff, volunteers, and contractors able to work with specialists in response to larger events requiring additional recovery capacity.
- (3) Identify priorities for recovery of collections based on significance and vulnerability to damage. The procedures should provide step-by-step instructions to evacuate or recover those items.
- (4) Include maintaining location information and recovery instructions both off- and on-site for immediate access.
- (5) Include establishing relationships with professional recovery companies.
- (6) Identify local or nearby sources for oversized freezers, refrigerator/freezer trucks.
- (7) Identify local or nearby sources for pertinent vendors to assist with recovery and stabilization efforts.
- (8) Identify local or nearby facilities to stage a triage operation if your facility is too severely damaged or is/will be without services for an extended period of time.
- (9) Identify potential short- and long-term storage locations for collection evacuation if there is potential to move collections in anticipation of an event.
- (10) Identify art handling companies or reliable moving companies that could provide rapid response for evacuation.
- (11) Identify vendors of materials commonly used in the recovery of museum collections. Canvas local retail outlets (larger chain discount/department and home improvement stores) to identify potential materials and supplies to assist with recovery efforts.
- (12) Include arrangements with a conservation facility for the stabilization or treatment of significant objects.

More information can be found in the *Field Guide to Emergency Response*.

A.6.8.3.2 A basic supply kit, stored in waterproof containers, should be maintained for quick response to small emergencies. The following items should be considered:

- (1) Using published materials on collection recovery, identify key supplies that might be used to form a recovery “cache.”
- (2) Identify local or nearby rapid delivery company depots where large quantities of materials could be delivered during recovery from major events.
- (3) Store order forms, account numbers, catalog descriptions of supplies, and so forth, off-site for ordering access if your facility is closed or is without services.
- (4) Partner with other local cultural institutions to consolidate a small cache of recovery supplies that could be made available for smaller incidents
- (5) Keep cache supplies separate from other supplies and appropriately label containers to ensure that they are immediately available for response.
- (6) For more information, see the *Field Guide to Emergency Response, Supplies Shopping List*, and in dPlan™ (<http://www.dplan.org/supp/emes/inhouse.asp#>)

A.6.8.3.3 A cultural resource property should provide appropriate means for replacing institutional collections in the event of partial or complete loss. Insurance (purchased or self-

funded) is one way of guaranteeing that funds will be available to restore the buildings and collections, and can help to compensate for loss of income associated with temporary closures. The perils covered should reflect significant hazards identified in the vulnerability study, if practical. Other issues to consider include the following:

- (1) Contractual or legal requirements for coverage
- (2) Policy limits, deductibles, and coverage
- (3) Right and obligations of policy holder
- (4) Claims reporting procedures and contact information
- (5) Method of valuation of property (e.g., replacement or reproduction cost vs. functional replacement cost or actual cash value that can result in inadequate coverage to pay for the full loss)
- (6) Definitions and sublimits for special coverages such as fine arts, valuable papers and records, computers and telecommunication equipment, electronic media and cyber risk
- (7) Addition of scheduled items within the policy
- (8) Means of addressing new and unscheduled acquisitions and buildings
- (9) Electronic copies of policies and supporting documentation should be backed up regularly and stored off-site

For additional information, see the following:

<http://www.loc.gov/preserv/emergprep/insurance-main.html>

“Risk and Insurance Management Manual for Libraries,” Mary Breighner and William Payton, edited by Jeanne Drewes, ALA 2005 ISBN 0-8389-8325-1

“A Legal Primer on Managing Museum Collections,” Malario, Marie, second edition 1998.

For state insurance code see, for example, <http://www.delcode.state.de.us/title18/index.htm>

A.6.8.3.4 Effective preparedness and response procedures require a commitment of staff time and financial resources. Prevention is the most cost-effective phase of the emergency management process. Some measures cost little or no money: clearing hallways of clutter, moving flammable materials away from heat sources, making copies of key records and storing them off-site, updating staff contact information, backing up computer files and systems daily. Larger expenditures can include hiring more security staff, installing or upgrading fire detection and suppression systems, and constructing safe storage on higher ground. Funds should also be set aside for response and recovery needs, including the purchase and maintenance of essential supplies and equipment, staff time for emergency drills, and fees for disaster training courses or workshops.

The vulnerability assessment can be used to identify financial priorities for soliciting donations and grants from a variety of the following sources:

- (1) Trustees and community supporters will appreciate requests for specific cost-effective measures.
- (2) Traditional sources of private sector funding for preservation support disaster planning and training programs.
- (3) State emergency management agencies and some state libraries have funds available for mitigation activities.
- (4) Grant and loan programs offer funding for prevention, planning, response, or recovery projects.

For additional information on resource allocation and funding sources see the following:

Dorge, Valerie and Sharon L. Jones, compilers, *Building an Emergency Plan: A Guide for Museums and Other Cultural Institutions*. The Getty Conservation Institute, 1999. www.getty.edu/conservation/publications/pdf_publications/emergency_plan.pdf

Before and After Disasters, Heritage Preservation, 2005. www.heritagepreservation.org/PDFS/Disaster.pdf

Open for Business, Institute for Business and Home Safety, 2006. www.ibhs.org

A.6.8.4.1 Components to be inspected and maintained can include, but should not be limited to, electrical systems, mechanical systems, roofs, windows, drains, and joints or seams that are critical in preventing infiltration of water, moisture, soot, or other particulate matter, thereby controlling indoor environments.

Sample maintenance checklists are provided in Annex I of this code and can be obtained from the Northeast Document Conservation Center at <http://www.dplan.org/prev/prev.asp>.

A.6.8.5.1.2 In smaller institutions, it is likely that one individual will fill several roles. Smaller institutions might consider cooperative agreements to expand the pool of team members, thereby increasing the depth of response coverage.

A.6.8.6 It is essential to determine if there are any health and safety issues that might affect the manner in which a team is deployed to begin the recovery effort. In each emergency situation, it is critical to survey the site, understand the cause of the damage, and work with institutional and emergency services personnel to mitigate any health safety issues prior to team members beginning work. An assessment of the severity and extent of the damage is also critical in developing immediate and long-term response needs, and in providing critical data to institutional management who will assist with the procurement of resources for the recovery effort.

A.6.8.7 It is important for emergency response teams to understand the incident management team structure to deal with a disaster that has consequences beyond an institution. An incident management team with an area scope of responsibility needs to be made aware of the conditions at each institution in order for emergency services personnel to be deployed to the areas of greatest need. That team also needs to be made aware of the special needs and concerns of cultural institutions.

This incident command structure also is a valuable tool for approaching smaller response efforts within the institution. Using the Federal Emergency Management Agency (FEMA) model, the first responder is the incident commander until someone with greater experience arrives. There are basic incident command on-line courses available from FEMA at <http://www.training.fema.gov/EMIWeb/IS/crslst.asp>.

A.6.8.8.1 An example of a field guide assessment form can be found in the front pocket of the *Field Guide to Emergency Response*. More information on the role and tasks of the assessment coordinator can be found on pp. 27–28 of the same publication.

A.6.8.8.2 The following items should be considered when documenting damage to collections:

- (1) Documentation should be based on collection inventory and include the values for individual pieces above an agreed upon value and by collections for lesser-valued items. Each institution must determine the level of individual item valuation based on vulnerability and resources to restore or replace damaged or lost items.
- (2) All collections should be covered unless the institution determines that the collection is not needed and has no value for the future.
- (3) Documentation of collections first by location and then by value should be maintained for use in the event of loss and claim negotiation.
- (4) Take photographs and/or videos of damaged items.
- (5) Documentation of damaged loaned materials should include a copy of the loan agreement with responsibility for insurance coverage during transit and onsite and steps for restitution.

For further information see <http://www.loc.gov/preserv/emergprep/insurancevaluation.html>.

For examples of loan agreements see <http://www.ala.org/ala/acrl/acrlstandards/borrowguide.htm> and

<http://rms.ucdavis.edu/EXHBLOANAGRMENT.doc>.

A.6.8.9 In an emergency, the situation can quickly become chaotic if response personnel do not understand their role or the appropriate chain-of-command for decisions. While the first inclination is to begin moving objects or calling additional personnel for assistance, on-site planning is critical to a successful recovery. As soon as the problem has been identified and an assessment of needs determined, critical personnel need to meet, even if only briefly, to communicate any safety issues, reaffirm the objectives of the effort, and clarify roles and assignments. This group, equivalent to the incident commander and command staff, operations, logistics, planning and finance chiefs, need to meet regularly during each day in order to communicate necessary information to all response team members.

A.6.8.10 Identify locations on-site, at neighboring institutions or in commercial facilities, that can serve as temporary storage for collections in advance of or after an incident. These facilities should provide environmental controls and be secure.

A.6.8.11.1.2 Central HVAC systems or smoke evacuation systems, if operational, can be used to cool or dry the climate. In general, mold can grow in relative humidity over 60 percent; however, depending upon the temperature and whether items have been wet, mold germination can occur at lower relative humidity. A mold risk calculator can be found and downloaded at <http://www.ImagePermanenceInstitute.org>.

Fans should be used to circulate air except in instances where mold or particulate debris is at risk of being spread through a collection area or into the ventilation system. The ventilation to a room or area affected by mold or debris can require dampers to protect other spaces.

Portable dehumidifiers can be used to effectively reduce relative humidity provided the units are appropriately sized to the volume of air that requires drying; however, the condensate must be connected directly to a drain or monitored and manually emptied to prevent water overflow in the space.

HEPA-filtered vacuums should be used to remove dry particulate debris to prevent the spread of small airborne particles.

A.6.8.11.2 For additional information see one of the following:

- (1) Annex K: Salvage of Water-Damaged Library Materials for discussion of priorities, triage, and stabilization. Information about assessment, documentation and salvage can be found in the *Field Guide to Emergency Response Supplies, and Vendors List*, 27–34.
- (2) The National Park Service Conserve O Gram Series 21 offers several leaflets on emergency recovery at http://www.cr.nps.gov/museum/publications/conservoogram/cons_toc.html.
- (3) More articles on emergency recovery can be found on the Disaster Preparedness and Response tab of Conservation Online (Cool) at <http://palimpsest.stanford.edu/bytopic/disasters/>.

A.6.8.12 Steps for recovery from the incident should include the following:

- (1) Funding options as follows:
 - (a) State and local emergency management agencies should be contacted first for available funding. State and local agencies are listed in the blue pages of phone books and available at www.fema.gov/about/contact/statedr.shtm.
 - (b) Federal disaster assistance is available only if the President of the United States declares a major disaster. To learn if a declaration has been issued, contact the appropriate state or local emergency management agency or see www.fema.gov/news/disasters.fema.
 - (c) Private, nonprofit cultural institutions and cultural institutions, under local, state, or tribal governance are eligible for federal assistance from the Federal Emergency Management Agency (FEMA) after a disaster has been declared. Cultural institutions under local, state, or tribal governance can apply to FEMA directly for assistance for both emergency work and repair work. Private, nonprofit cultural institutions can apply directly to FEMA only for emergency work such as debris removal. For permanent repair work, private, nonprofit cultural institutions can apply first to the Small Business Administration (SBA) for a loan. If the institution is not eligible for an SBA loan, or the amount needed exceeds the loan, institutions can apply for FEMA assistance. Information on FEMA and SBA policies is available on the Internet, although specific URLs are modified periodically. The web site of the Heritage Emergency National Task Force (www.heritageemergency.org) should have up-to-date links.
 - (d) Depending on their Congressional mandate, several other federal agencies make emergency grants readily available under special circumstances. See the National Endowment for the Arts (www.arts.gov) and the National Endowment for the Humanities (www.neh.gov) in particular.
 - (e) Private sector funds are also available after major events from corporations, foundations, and regional and state library, museum, archives, and historic preservation organizations.
 - (f) To improve chances of recovery from a disaster, the prudent institution will do the following:
 - i. Become familiar with potential sources of recovery funding and application procedures.
 - ii. Build recovery reserves into annual budgets. Create a list of prevention and mitigation measures that need funding. Following a disaster, support for emergency preparedness projects will increase.
- (2) Re-supply. Provision for re-supply of recovery materials should be provided. Inventory of disaster recovery supplies should be done periodically and expired materials replaced. Inventory and replacement of expended supplies should be done within two months of use of materials from an event.
- (3) Insurance negotiation and payment as follows:
 - (a) Report your loss to your insurance company or agent as soon as possible as required by your policy.
 - (b) Document damage including debris.
 - (c) Document all conversations and meetings with insurance company and their agents. Document date and time.
 - (d) Protect property from further damage.
 - (e) Separate damaged from undamaged property (required by policy).
 - (f) Save all receipts after damage to qualify reimbursements for property replacements, extra expenses.
 - (g) Confirm coverage with insurance company before contracting for emergency services.
 - (h) Be aware of FEMA regulations and reimbursements. See <http://www.fema.gov/>

A.6.8.13 Every stage of planning and response should be reviewed post emergency. The level of assessment required should be scaled to the magnitude of the incident. Information gleaned through this review process should inform an institution's preparation for planning. The protection plan, preparations, and future procedures should be modified as needed to improve future incident response.

As a minimum the post-incident report should include a description of the incident including the time and duration, staff and external parties involved in the response and recovery, and a basic accounting of the number of collections affected and the severity of damage.

For larger incidents a more complex report might be required, particularly if building structure or operations are affected.

A.6.12.1 The Federal Emergency Management Agency (FEMA) offers a variety of on-line training courses on the concepts of the incident command system (see www.fematraining.gov).

A.7.1.1 An important element of the vulnerability assessment is a qualitative or quantitative fire risk assessment. Techniques for preparing a fire risk assessment are presented in the *SFPE Engineering Guide to Performance-Based Fire Protection Analysis and Design of Buildings*; NFPA's *Fire Protection Handbook*, Chapters 3.7, 3.8, and 3.11; and the *SFPE Handbook of Fire Protection Engineering*, Section 5. NFPA 551 provides guidance on how to evaluate fire risk assessments.

A.7.1.4 Competent application of systems analysis is a powerful tool in identifying cost-effective alternatives to achieve fire safety goals. For assistance, see NFPA 550.

A.7.2 This chapter describes the types of information needed in the fire safety management component of the protection plan. The protection plan's complexity will relate to the size and structure of the organization. The extensiveness of the response will be scaled to the magnitude of the event — a small trash can fire will not require the same resources as a major fire incident. Nonetheless, every institution should have an understanding of the elements that comprise a comprehensive fire safety management component of the protection plan, and be prepared to develop procedures that fully addresses the protection of its facility and collections.

A.7.2.1 The fire safety management component of the protection plan should address the following topics as appropriate to the circumstances of a particular building:

- (1) Compartmentation
- (2) Structural analysis
- (3) Alarm and communication
- (4) Means of egress
- (5) Smoke control
- (6) Fire suppression
- (7) Water supply
- (8) Ignition prevention
- (9) Fire department/public protection response
- (10) Fuel control
- (11) Security

A.7.3 The fire safety manager can be an employee of the institution who has certification, education, training, and/or experience with generally accepted fire protection practices. Institutions can also use appropriate outside resources, such as consulting engineers, fire department personnel, insurance company loss control representatives, code officials, or other individuals with similar credentials.

A.7.3.3 Such hazards can include candles, fireplaces, conservation labs, exhibit fabrication facilities, and so forth.

A.7.4.1 Some records should be kept longer than others. The fire safety management component of the protection plan should specify the retention period for each type of record.

A.8.1.1 NFPA 730 provides guidance on conducting security vulnerability assessments and developing appropriate countermeasures.

As outlined in NFPA 730, a security vulnerability assessment (SVA) usually involves a seven-step process as follows:

Step 1: Formation of Team. The process should begin with the formation of a team of personnel from all organizational areas. Commonly, the individual responsible for an organization's security serves as team leader.

Step 2: Organization/Facility Characterization. Step 2 involves a characterization of an organization and the facilities to be protected. It includes identification of assets (i.e., people, property, information, and products); physical features and operations; laws, regulations, and corporate policies; social and political environment and internal activity (i.e., community resources, crime statistics, internal activities, and loss experience); and review of "current layers of protection," including both site security features and safety measures.

Step 3: Threat Assessment. The next step is conducting a threat assessment. The process includes a classification of critical assets, identification of potential targets, consequence analysis (effect of loss, including any potential off-site

consequence), and the definition of potential threats (by identifying potential adversaries and what is known about them).

Step 4: Threat Vulnerability Analysis. The next step is conducting a threat vulnerability analysis that identifies actual and potential threat scenarios and estimates a relative security risk level. The relative security risk level is a function of determining the severity of the consequences of an adversarial event, the potential for such an attack, and the likelihood of adversary success in carrying out the anticipated event or activity.

Step 5: Definition of Specific Security Countermeasures. In this step, specific security countermeasures are defined. All information from the preceding steps, including characterization, threat assessment, and vulnerability analysis, is considered. An effective countermeasure is one that drives improvements in mitigating the defined threats and results in a reduction in the security risk level.

With respect to the development of security countermeasures, and in consideration of the defined threats, the SVA team's efforts to strengthen the security layers of protection begins with a focus on the concentric circles of protection design methodology, shown in Figure A.8.1.1.

This methodology provides for protection of defined critical assets by considering the following four primary protection elements of an effective protection plan design:

- (1) Deter — discouraging an adversary from attempting an assault by reducing the likelihood of a successful attack.
- (2) Detect — determining that an undesirable event has occurred or is occurring. Detection includes sensing the event, communicating the alarm to an attended location, and assessing the alarm.
- (3) Delay — impeding adversary penetration into a protected area.
- (4) Respond — counteracting adversary activity and interrupting the undesirable event.

Arson, theft, sabotage, or other malevolent acts can be prevented in two ways, by either deterring the adversary or defeating the adversary. In the development of security countermeasures, it is important to understand that a properly designed and implemented security program integrates people, procedures, and technologies for the protection of assets. The use of technologies alone is not the solution.

The "new world" we live in poses a new challenge: the increased presence and threat of adversarial attack. Our journey now involves an important dual approach, the combination of today's security methodologies with traditional safety and risk management practices to strengthen security layers of protection.

An effective security program, resulting from the completion and implementation of a comprehensive SVA, provides measurable benefits in the workplace for personnel (staff, guests, and visitors), in the protection of property, and in operations, resulting in enhanced business performance.

Step 6: Assessment of Risk Reduction. Taking into account the countermeasures defined in Step 5, this step reassesses the relative security risk levels developed in Step 4 and considers additional security risk reduction measures (security countermeasures) where appropriate.

Step 7: Documentation of Findings and Tracking of Implementation. Findings and recommendations are documented in

a report and the implementation of accepted recommendations is tracked.

A.8.1.2 Terrorism is the use of force or violence against persons or property in violation of the criminal laws of the jurisdiction for purposes of intimidation, coercion, or ransom. Terrorists often use threats to create fear among the public, to try to convince citizens that their government is powerless to prevent terrorism, and to get immediate publicity for their causes. Acts of terrorism include threats of terrorism, assassinations, kidnappings, hijackings, bomb scares and bombings, cyber attacks (computer-based), and the use of chemical, biological, and nuclear weapons. In addition to high-risk targets, such as military and other governmental facilities, airports, and high-profile landmarks, terrorists might also target large public gatherings, water and food supplies, utilities, and corporate centers. Further, they are capable of spreading fear by sending explosives or chemical and biological agents through the mail. You should prepare for a terrorist event in much the same way you would prepare for other crisis events.

A.8.2 The objective of a security component of the protection plan is to ensure that security measures and personnel respond in an integrated and effective way to mitigate the effects of an adversarial act in a manner that is appropriate for that particular organization or facility.

In addition to features of protection, the security component of the protection plan usually includes a concise statement of purpose, identifies the intended users, designates where the master copy is maintained, identifies to whom it has been distributed, and contains clear instructions for its use.

Specific items in the security component of the protection plan should be based on the potential threats faced by the organization or facility as determined by the security vulnerability assessment (SVA). Given a potentially broad range of threats, however, priority should be given to items that accomplish the following:

- (1) Address events that are most likely to occur and have the greatest potential impact on defined critical assets
- (2) Allocate sufficient time and resources for planning, development, and implementation

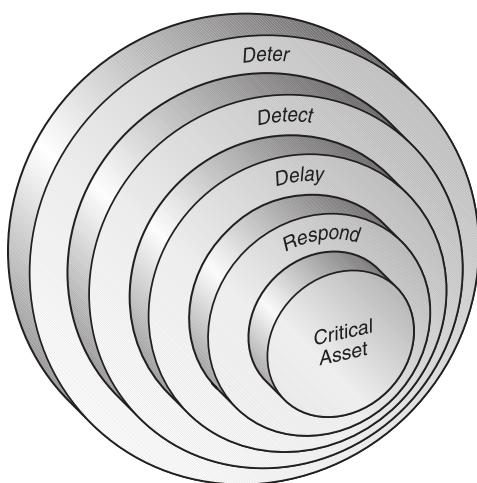

FIGURE A.8.1.1 Concentric Circles of Protection. (Source: SafePlace Corporation.) [730:Figure A.5.2.3(5)]

- (3) Identify and collect the information necessary to develop effective procedures
- (4) Are specific and comprehensive

The objectives of the security component of the protection plan should be obtainable and easily understood. The underlying assumptions of the protection plan should be fully examined to make sure that they are correct and well thought out. Responsibilities and authorities of facility personnel should be clearly identified and assigned. Alternatives and options should be incorporated into the protection plan to make it flexible and capable of responding to changes or unexpected events. The security component of the protection plan should be reviewed on a regular basis to determine whether all aspects are still appropriate.

Benefits of Security Planning.

A protection plan provides facility personnel with an effective means of assisting in the prevention and mitigation of the effects of security incidents by integrating those approaches that have proven to be effective in that environment (and others) in the past. This is especially important for new personnel.

When facility personnel are confronted with an incident or situation that is unforeseen, a protection plan can assist in directing personnel to react in a manner that is appropriate to the situation.

For incident responses that require coordinated actions by many facility personnel (such as evacuations), a protection plan with a clear, concise, and useful set of staff activities and responsibilities helps to ensure a rapid and effective response.

Even if the protection plan is not implemented exactly as envisioned, contingency planning has the following advantages:

- (1) Facility personnel respond more rapidly and effectively than if no planning had taken place.
- (2) It promotes an understanding of the issues involved in responding to a variety of threatening or dangerous situations.
- (3) It ensures development of complex responses to complex situations.
- (4) It provides for a complete examination of difficult and controversial issues, such as who has authority to call for an evacuation, or whether ransom will be paid to kidnappers and hostage takers.
- (5) It identifies information that must be gathered to respond to an emergency, such as names and up-to-date telephone or radio contact information of all facility personnel and local police.
- (6) It identifies preparations that must be made for an emergency response, such as obtaining communications equipment, consolidating personnel and sensitive records, or keeping funds on hand for an evacuation.
- (7) It promotes a sense of ownership and buy-in to the protection plan among facility personnel who participate in the planning and who will be impacted by it.
- (8) It ensures a clear division of tasks and responsibilities among facility personnel, helping to avoid important things being left undone and the unnecessary duplication of effort.
- (9) It produces a protection plan that, though perhaps not completely applicable to every situation, can serve as a baseline or starting point for action should an emergency arise.

- (10) It identifies training and resource needs of facility personnel, reflecting assigned responsibilities. Personnel should be oriented to the protection plan and trained in the skills necessary to enable them to fulfill their assigned responsibilities.

Elements of the Security Component of the Protection Plan.

Facility/organization mandate/mission should include a summary of the threat/risk assessment situation, as well as the facility/organization security strategy.

Procedures for movement, communication, facility management, reacting to security incidents and reporting/analyzing incidents are part of the protection plan. Specific items in the security component of the protection plan include the following:

- (1) Security vulnerability assessment
- (2) Description of the facility and organizational structure
- (3) Security organization and operations
- (4) Threat assessments and risks
- (5) Employee, visitor, and vendor safety

Additionally, items in the security component of the protection plan can include the following:

- (1) Protective barriers
- (2) Security and emergency lighting
- (3) Alarm systems
- (4) Access control (mechanical and electronic)
- (5) Electronic surveillance
- (6) Computer operations
- (7) Communications
- (8) Security staff: organization, capabilities, resources, and procedures
- (9) Contingency plans: criminal attacks, terrorist attacks, accidents, natural disasters
- (10) Outside resources: local, state, and federal public safety (e.g., law enforcement, fire and emergency medical services)

The supporting information should include the following:

- (1) A personnel roster, addresses, telephone numbers, and passport numbers
- (2) A list of cooperating agencies, contact people, telephone numbers, and radio frequencies
- (3) A list of important contact people (government officials, security personnel, airport and transportation authorities, utility companies, health care facilities and clinics, etc.)
- (4) Maps (regional, national, sub-regional, local) indicating assembly points, overland routes, air fields, border crossings, and so forth
- (5) Emergency supply inventory (including food, medical, documents, and clothing)

The components of a contingency plan are as follows:

- (1) Nature of specific incident
- (2) General concept of how to react to the incident, including the sequence of personnel activities
- (3) Division of responsibilities and authorities among the facility personnel, including who can initiate the emergency operations component of the protection plan
- (4) Identifying who is covered by the contingency plan (e.g., who is to be evacuated?)
- (5) Information on how to contact all personnel

- (6) Resources that should be applied to the management of the incident
- (7) Guidance on the emergency use of funds, disposition of project property, and personal effects
- (8) List of annexes, including maps, forms, location of personnel, telephone numbers, radio frequencies, extraordinary procedures, and so forth.

A.8.2.3 It is important to control the threat of arson. [See Table B.2(b), Table B.3(b), and Table B.4(b).] Precautions can minimize the likelihood of a serious fire. The most common fire setters are juvenile fire starters, vandals, disgruntled patrons, and employees. They might break in at night or gain legitimate access during normal operating hours. Experience indicates that if unsuccessful fire arson has occurred, a repeat attempt is likely unless the fire setter is brought to justice. The cultural resource property then becomes a specific target, and extra precautions are warranted. The following special precautions are suggested as recommendations for high-risk properties:

- (1) The strongest deterrent to fire setters is good security. Suggested elements of a sound security program are as follows:
 - (a) Reasonable surveillance, including use of premises protection systems, CCTV, and electronic access control systems, of all areas accessible to the public, with spot checks at regular intervals. All nonpublic areas should have controlled access.
 - (b) A background investigation for stability and character should be conducted, to the extent legal restrictions allow, on potential employees, security personnel, and others having free access to the entire facility.
 - (c) All accessible openings, including doors, windows, vents, and roof access, should be properly secured. Fire exits should be arranged to prevent entry from outside. Doors and windows should be checked to make sure locks are in good repair.
 - (d) Exterior lighting is an effective and often underrated security measure against arsonists and other miscreants. Where not provided by public utilities, lighting should be added at all concealed approaches to the facility.
 - (e) A rigid closing procedure, including supervisory follow-up responsibility, should be established to ensure that all unauthorized people have left the building, that openings are secured, and that fire hazards, including ashtrays and trash receptacles are checked.
 - (f) Many fires have been set in book returns. Book returns should be constructed to prevent the spread of fire and smoke from the return into the rest of the library. A better alternative could be to eliminate the inside book return and provide an outside receiving bin away from the exterior walls of the library building.
 - (g) Crime prevention through environmental design (CPTED)
- (2) High-risk locations require a higher level of precaution when any of the following conditions exist:
 - (a) Properties in high-crime rate area
 - (b) Cultural resource properties associated with or connected to social or political causes
 - (c) Locations having previously incurred an arson fire or threat

- (d) Facilities where seriously strained relations between employees and management exist
- (3) For facilities in high-risk locations, the following precautions should be employed:
 - (a) Provide security/guard service during idle periods or intrusion alarms connected to a reliable, constantly attended location
 - (b) Establish liaison with police and fire departments
 - (c) Provide/install closed-circuit television and monitors for remote areas with public access, because the cameras provide a formidable psychological deterrent to arsonists, vandals, and other wrongdoers
 - (d) Supplement outside lighting with a 2 m (7 ft) wire fence in concealed access areas of the building
 - (e) Cutting back bushes, shrubs, and other plant materials that could provide cover for an intruder

A.8.2.5 The nature of libraries — their access by the public, with many areas obscured from view of attendants — results in their being an opportune target for arsonists as well as others bent on other forms of malicious damage. The most common fire setters are juvenile fire starters, vandals, disgruntled patrons, and employees. They can break in at night or gain legitimate access during normal operating hours. A frequent method of external attack has been to place burning materials into the book return.

A.8.2.6 Cultural resource properties should take the following steps:

- (1) Develop written policies and procedures for terrorist events, train personnel about them, and test the effectiveness of the plan.
- (2) Provide a prepared on-site area of refuge for guests and employees should an off-site consequence prevent travel from the facility. Preparations should include provision of nonperishable food and drinking water, battery-powered commercial radio/television, first aid supplies, sanitation supplies, flashlights, and so forth.

Protection Against Cyber Attacks.

Cyber attacks target computer or telecommunication networks of critical infrastructures such as power systems, traffic control systems, or financial systems. Cyber attacks target information technologies (IT) in three different ways. The first type of attack is a direct attack against an information system “through the wires” alone (hacking). The second type of attack can take the form of a physical assault against a critical IT element. Finally, an attack can originate from the inside as a result of a trusted party with access to the system compromising information.

Cultural resource properties should be prepared for the following situations:

- (1) To do without services you normally depend on that could be disrupted — electricity, telephone, natural gas, gasoline pumps, cash registers, ATM machines, and Internet transactions
- (2) To respond to official instructions if a cyber attack triggers other potential threats — for example, general evacuation, evacuation to shelter, or shelter-in-place, because of hazardous materials releases, nuclear power plant incident, dam or flood control system failures

Preparing for a Building Explosion.

Explosions can collapse buildings and cause fires. Cultural resource properties can do the following:

- (1) Regularly review and practice emergency evacuation procedures.
- (2) Know where emergency exits are located.

Additionally, cultural resource properties should consider keeping the following items in a designated place on each floor of the building:

- (1) Portable, battery-operated radio and extra batteries
- (2) Several flashlights and extra batteries
- (3) First aid kit and manual
- (4) Several hard hats
- (5) Fluorescent tape to rope off dangerous areas

A.8.2.7 If an unattended, suspicious object, container or package (e.g., purse, briefcase, backpack) is discovered, immediate efforts must be made to identify its owner. The item should not be disturbed and radio/cellular communications should be avoided within the immediate vicinity. Potential witnesses should be interviewed to find out if they saw anyone leave the item or how long it has been there. Consideration should be given to the question of whether the unattended item was found in conjunction with a bomb threat, or if there is a compelling factor that makes the object, container, or package particularly suspicious, or if the location is such that an attempt to hide the object was likely. After all reasonable leads have been exhausted, clear the area within “line of sight” of the object, container, or package and notify the police.

A.8.3.1 Employers can ensure a high level of integrity in the workforce by considering the following practices:

- (1) Background checks that include an identity check, 3-year employment check, confirmation of address (utility bill), criminal records check, and a full employment history and reference check for all individuals with access to critical assets.
- (2) When outside services, (contractors, vendors, or other personnel) are used, management should ask the vendors/contractors’ management about their pre-employment screening and drug testing practices.
- (3) A drug testing program should be established.

Negligent hiring liability is a basis for recovery against employers for the wrongful or criminal actions of employees against third parties, whether those actions are performed within or outside the scope of employment. The requirements of this tort are satisfied when the offending employee is hired without an adequate background investigation and when such an investigation would have indicated the applicant was a potential risk.

Pre-employment screening not only is necessary for hiring the best personnel available for the success of an organization, but it can help in protecting against negligent hiring lawsuits. The courts are increasingly upholding the negligent hiring doctrine. They are taking the position that the employer should make every effort to ensure that the employee selection process is a reasoned and useful exercise.

A great deal of information is available to an employer willing to invest the time and make a reasonable effort to screen employees. Public records, for example, can tell if an applicant has been convicted of a crime, if he or she has sued a previous

employer, or if he or she has been the subject of a fraud investigation. Records can verify an applicant's identity, document his or her self-employed business experience, and answer many other questions.

Employers cannot know absolutely, in advance, that a prospective employee will later cause injuries to third parties. Therefore, employers are not exposed to liability simply because they failed to check an applicant's background. It is only when such a check would have revealed information indicating the undesirability of the applicant that the failure to obtain the information can be considered negligence.

The extent of the background investigation performed on an applicant should be proportional to the degree of risk presented by the position to be filled. For employees who have frequent contact with the public or close contact with persons due to a special relationship, the courts have stated that the employer has a duty to use reasonable care in hiring the person.

Employers have numerous options available to screen applicants, such as resumes and job applications, reference checks, interviews, and background checks. While some can be time-consuming and expensive, many are fairly straightforward and cost-effective. However, the failure to investigate properly can have more severe consequences.

While courts have imposed a responsibility on employers to use due care in screening job applicants, federal and state privacy laws impose restraints on employers that have made the task more difficult and demanding. These laws determine the type of information an employer can request and prescribe how the information can be handled. An employer who does not comply with these laws can become the victim of a discrimination lawsuit initiated by a job applicant. For this reason, businesses should understand the privacy rights of job applicants. These rights are provided in laws such as the Discrimination in Employment Act, Title VII of the 1964 Civil Rights Act, the Immigration Reform and Control Act, the 1973 Rehabilitation Act, the Americans with Disabilities Act (ADA), the Fair Credit Reporting Act, and the Privacy Act.

Cultural resource properties are advised to establish a facility-wide policy regarding pre-employment screening practices and to be consistent in applying the policy. If, for example, the policy calls for criminal background checks on security officers, then these checks should be obtained for each applicant who is hired as a security officer. Additionally, all information obtained from the background investigation should be well documented, kept confidential, and secured in a safe place.

A.8.3.2 All cultural resource properties should adopt a policy on access control that regulates access of all persons, including all staff at all levels, contractors, visitors, scholars, and others. This policy should define who can enter the facility, and, as appropriate, high-security areas of the facility, and the hours of the day and days of the week they can enter or be denied entry. Access to non-public portions of the cultural resource property should be limited to those persons needing access to carry out their duties.

Employees should not be permitted to work or to remain in the cultural resource property after hours if doing so results in diminished security. This might occur if their presence prevents the alarm system from being activated and when

supplementary security officer presence cannot be provided in unprotected spaces.

Visitors to non-public portions of a cultural resource property should sign in and be announced.

Access to collection storage should be limited to staff with a need to visit storage. Scholars and students who require access to the collection materials should be accompanied at all times by qualified professional or protection staff personnel.

Tours, members of the public, and the press should not normally be permitted in storage areas. Educational tours or classes in storage, when undertaken, should be accompanied by security or security trained personnel on a ratio of at least one security officer for each 10 visitors, plus appropriate curatorial staff. Picture taking, including photos by members of the press, are not advisable in collection storage.

Employees and administrative visitors should be required to enter and leave the cultural resource property via designated entrances, controlled by security personnel.

Members of the public, contractors, and others should be required to enter and leave via entrances under the control of security personnel. All entrances and exits to and from the cultural resource property through which objects can be removed should be protected by locks, alarms, and/or security officers.

Access to storage and other areas with high-value assets should be controlled by appropriate means such as, but not limited to, locks, alarms, and/or security officers.

All visitors to non-public areas and all contractors should be issued an ID card that they should be required to wear on an outer garment at all times when in the building. The card should be color-coded and numbered so that the identity of the visitor can be easily ascertained by comparing the number with the visitor sign-in log.

In any cultural resource property where the total number of staff members, including volunteers, docents, and unpaid personnel of any category, exceeds 30 people, a photo ID card should be worn on an outer garment at all times when in the non-public portions of the building, or in the public portions of the building or grounds after hours. All persons should display their ID card to the security officer when entering the building.

Photo ID cards should be no smaller than 2 in. by 3 ¼ in. in size and should be laminated or otherwise secured to make forgery or tampering unlikely. The card should include the photo, name, and number of the employee, the name of the institution, date of expiration, and other data that management deems appropriate.

A.8.3.4.1 Examples of qualified personnel include individuals who can demonstrate experience on similar systems that they are designing. The designer has to take into consideration the threat that the system is being designed for as well as provisions to minimize the possibility of false alarms.

A.8.3.4.2 The installation of electronic premise protection systems should not impact the ability of the museum's visitors to view the exhibits. It is unwise to simply do an Internet or "Yellow Pages" search for electronic premises security systems. A better approach would be to find a security consultant to assist in developing a security vulnerability assessment.

The installers of electronic premises security systems should be familiar with the equipment that they are to install. This includes knowing the limits of the devices and appliances for a particular design. The installer should have an understanding of the causes of false alarms and methods that can be taken to decrease the possibility of their occurrence. Some jurisdictions can require a license or permit for the installation of security devices.

A.8.3.5 The following includes descriptions and usage guidance for various types of common physical security devices including builders' hardware, locks, doors, and windows.

Locking Hardware. Locks are designed to provide various levels of deterrence or delay entry, and are an integral part of an overall security system. Egress and fire resistance provisions relating to doors and hardware in NFPA 101, NFPA 72, and NFPA 80 should be maintained. Individual products should be listed to the standards in the following as applicable:

- (1) ANSI/BHMA A156. Series performance standards include security tests and are shown in the applicable sections.
- (2) UL 1034 for burglary-resistant electronic locking mechanisms.
- (3) UL 437 for key locks.
- (4) UL 768 for combination locks.
- (5) UL 294 for access control system units.
- (6) UL 2058 for high-security electronic locks.
- (7) UL 305 for controlled exit panic devices.

Types of Locks. Locks can be divided into three general classes:

- (1) Those that operate on purely mechanical principles
- (2) Those that are electromechanical and combine electrical energy with mechanical operations
- (3) Those that are electronic

Keys. Keys and locks are often the first and only level of physical security control for many organizational assets. Consequently, key control or the lack of it can mean the difference between a relatively secure activity and extraordinary loss. Almost all organizations utilize some type of key access in everyday operations. Each day offers an opportunity for key mismanagement or unauthorized duplication, which can lead to mild annoyances such as the replacement and cost for lost keys, or to more serious losses, such as theft or personal injury. A good key control system will maintain a strict accountability for keys and limit both key duplication and distribution. Refer to ANSI/BHMA A156.28. Keys should meet ANSI/BHMA A156.5 Cylinder Section, and ANSI/BHMA A156.30 in the appropriate grade for the application.

Types of Keys and Cylinders. Proprietary keyways or patented cylinder and key mechanisms are available with controlled distribution to prevent unauthorized key duplication. When they are combined with any of the various locking hardware described below, consideration should be given to the need for a patented high-security or patented key control cylinder on keyed functions. Operating or "change" keys are keys that are used to open locks. Duplicate keys are copies of operating keys and are usually stored for use in an emergency or to replace a lost key. Duplicate keys must be kept to a minimum and be protected to avoid proliferation and loss of accountability. Master keys are designed to open all locks of a particular series. Key systems can have one grandmaster key for the overall system and several sub-master keys for each subsystem. Master

keys can be used as a convenience — for example, carrying one key instead of numerous keys — but their use increases susceptibility to picking and duplication and must be carefully controlled. Construction keys open removable core lock cylinders installed on the doors during construction of a facility. These cores are replaced at the end of construction with cores subject to the facility's key system. Control keys are used to remove and replace these cores. Control keys are used only in interchangeable core cylinder systems.

Key Accountability Procedures. The integrity of a key system is important to safeguarding property and controlling access. Lost or stolen keys and key blanks can compromise the security of a key system. The security officer should ensure that responsible individuals maintain control over the facility's key system by storing, issuing, and accounting for all keys under the facility's control. Issuance of keys must be kept to a minimum. Keys should be issued only to persons who have an official need. Accurate accountability records must be kept and should contain the information listed below. PC-based software and key storage cabinets and computer-controlled key retention and distribution systems are available to facilitate the management of a master key system and help to ensure its long-term integrity.

Procedures should include the following:

- (1) When a key to a designated controlled or restricted area is lost, the locks to the area must be changed.
- (2) Access lists for persons authorized to draw master keys should be maintained.
- (3) The key storage container/cabinet should be kept locked with a pick- and drill-resistant, patented high security cylinder that is not keyed to the facility master key system.
- (4) The container/cabinet should be checked periodically in accordance with the security component of the protection plan.
- (5) All keys should be inventoried at least annually.
- (6) Requests for issuance of new, duplicate, or replacement keys should be made in writing and approved or monitored by the security officer.
- (7) Keys not issued or no longer needed should be destroyed or stored in a locked container.
- (8) Protection of keys should be a priority at all times.
- (9) Identifying key tags with user or facility names on rings is not recommended; if keys are lost, it's an open invitation for misuse.
- (10) Keys should not be left on desks, in unlocked drawers, or where they can be easily taken and copied.
- (11) Employees should be reminded to keep official keys on their person or securely locked in a desk or cabinet, and that they are not to lend them to individuals not specifically authorized.
- (12) Employees should promptly return official keys checked out on a temporary basis.
- (13) Lost keys should be immediately reported to the appropriate official, and locks should be re-keyed immediately and new keys issued when keys are lost or stolen.
- (14) Keys should not identify the specific premises or access doors that they open.

Records should include the following:

- (1) Number assigned to each key and lock
- (2) Location of each lock (room number)
- (3) Person to whom keys have been issued

- (4) Date of issuance
- (5) Recipient's signature for keys issued

Electronic Cylinders. Electronic cylinders are useful in applications where there is a high user turnover and a need to collect access data and limit access to particular periods. They are often used in conjunction with card readers, biometrics, and so on. Electronic cylinders should meet the requirements of ANSI/BHMA A156.30 in the appropriate grade for the application.

Flush Bolts. Flush bolts are used in pairs of door openings requiring only one leaf for normal use or to meet an exiting requirement where the occasional use of a larger opening is required. Flush bolts are small deadbolts that go into the floor and ceiling and typically keep the second door in a pair of doors closed. Flush bolts are frequently used on pairs of doors in conjunction with a lock or exit device on the active leaf. Flush bolts can be either manual or automatic. Automatic (not manual) flush bolts are used on the inactive leaf of a fire-rated door in a pair of doors. Automatic bolts use the closing action of the active leaf to activate the latching. Periodic inspection for warped, weakened, or otherwise misaligned doors should be conducted to assure activation of top and bottom bolts. This inspection should include a check to assure that there are no obstructions or foreign objects in frame or floor strikes. In non-fire-rated applications, manual flush bolts secure the second door in a pair. Key lockable flush bolts are surface applied and can be used to prevent inactive leaves of a pair from being opened.

Coordinators. A pair of doors often require a coordinator. These devices mount on the top jamb and hold one door open until the other door closes, which allows the door to latch shut properly. Without a coordinator, doors can easily be left propped open inadvertently.

Built-In Locks. When a security container or vault door is used to safeguard confidential information, it should be listed and equipped with a lock designed to prevent the user from leaving the container in the “closed but unlocked” condition.

Combination Locks. A manipulation-resistant combination lock provides a high degree of protection. It is used primarily for safeguarding classified or sensitive material. Its technical design is to prevent the opening lever from coming in contact with the tumblers until the combination has been dialed. These locks are available with mechanical or electronic dials.

Combination Padlocks. Combination padlocks are used primarily on bar-lock filing cabinets. They are not rated for resistance to physical attack and are not recommended for outdoor use. Procedures for changing combinations, protecting combinations, and recording combinations should also be followed for combination padlocks.

Exit Devices.

Exit devices are used where occupancy levels require unimpeded single-motion egress. Typical locations include at an opening from an area of assembly and at all latched openings in the direction of the building exit. Exit devices are also required in hazardous locations, often so designated because of the presence of gas, chemicals, or flame. Selection of an exit device should include an evaluation of the environment. Non-fire devices can be equipped with “dogging,” which holds the latch(es) retracted for extended periods of time. This makes

entry easier, reduces wear, and allows designers to use pulls instead of functioning trim to limit vandalism.

In areas exposed to abuse, the use of vertical rods should be limited to those locations where they are the only acceptable alternative. Additional steel covers to retard damage can protect rods. Surface vertical rods are susceptible to bending and other damage by carts. For security as well as fire code compliance, vertical rod latches must latch at top and bottom; otherwise, flexing in the door can allow criminal entry. Use of a threshold with vertical rods will provide a better mounting surface for bottom strikes. Vertical rod deadbolt exit devices provide further resistance to forced entry.

Cross-corridor double egress pairs of door openings typically require vertical rods in pairs. Pairs of doors swinging in the same direction can either be vertical by vertical or vertical by mortise exit device. When fire doors are required to have an overlapping astragal, the use of a vertical by mortise system is required. The latter application also requires a coordinator. The securest approach to pairs of doors swinging in the same direction is to use a mullion and two rim or mortise devices.

Electrified exit devices are available in various functions. Electric dogging will hold the latch retracted once the power is applied, allowing push/pull operation. Electric latch retraction allows dogging the device without going to the device. Both of these applications are convenient for fire-rated exits that are not permitted to be mechanically dogged. Electric latch retraction can be combined with an access control system to provide controlled entrance even on pairs of doors that latch at the top and bottom. Electric latch retraction can be combined with an auto-operator to provide access for the physically impaired. Electric strikes or electric control trim can be added to exit devices to provide electric release.

Bored/Cylindrical Locks. These lock designs provide convenient installation along with moderate security. Different locking functions are offered to meet access needs, such as non-keyed locking (for bathroom) and keyed entry. For enhanced resistance to forced entry, doors with these locks can have a separate deadbolt mounted on the door, depending on local codes, as the second lock requires two actions for egress. Recent product developments have greatly increased the strength and durability of these locks in order to retrofit existing installations with more secure locking solutions. These locks should meet ANSI/BHMA A156.2 and UL 437 in the appropriate grade for the application.

Interconnected Locks. These lock designs combine cylindrical locks and deadbolts and are used in residential occupancy where one motion is required to open the door. They include independently installed cylindrical and deadbolt locks that contain a linkage that allows instant retraction of the deadbolt with movement of the interior lever handle or knob. They combine the security and safety of a latching device with the security of a deadbolt. These locks should meet ANSI/BHMA A156.12 and UL 437 in the appropriate grade for the application.

Mortise Locks. These lock designs are typically used in institutional and high-rise residential applications. They can incorporate both a latch and deadbolt in the same body. Mortise locks allow a deadbolt with latch in a path of egress by retracting the latch and deadbolt in a single motion. Mortise locks can be designed with a low-cost failure point, shear pin, spindle, and so forth, making their application attractive for locations that

are apt to receive a lot of abuse. Mortise locks should meet ANSI/BHMA A156.13 and UL 437 in the appropriate grade for the application.

Electromechanical Locks. Electromechanical door locks are primarily used to control entry into an area. They can be opened via key (mechanically activated) or electrically by receiving power from a power supply after the valid presentation of a code to a secure encrypted electronic credential (e.g., magnetic-stripe card, proximity card, smart card, digital keypad). They can also be remotely activated by a simple push-button or intercom system. Some of the advantages of using these locks are code compliant operation, low cost, easy installation, simple operation, and integration with access control systems. Electromechanical locks should meet ANSI/BHMA A156.25 in the appropriate grade for the application. Electrified locking devices should also meet the performance requirements as defined by the applicable ANSI/BHMA A156 standards for the product and grade specified by the manufacturer and listed to UL 1034.

Electromagnetic Locks. These lock designs provide reasonably high levels of force resistance in high traffic access controlled areas. The use of electromagnetic locks must not alter the requirement for fire-rated hardware or single-motion egress. Electromagnetic locks should meet ANSI/BHMA A156.23 in the appropriate grade for the application and listed to UL 1034 for burglary-resistant electric locks.

Delayed Egress Locks. Delayed egress locks were designed for use in retail applications and are valuable in many applications to provide reasonable security by operating on a delay with an alarm in non-emergency situations. They can only be installed where permitted by code and must be released instantly (without delay) by the fire alarm system in the event of emergency. They should meet ANSI/BHMA A156.24 in the appropriate grade for the application and be listed as “Special Locking Arrangements.”

Electric Strikes. Electric strikes provide electric release via access control or pushbutton interface for use with bored/cylindrical locks, mortise locks, or exit devices. Models are available for use in both fail-safe and fail-secure situations. Fail-safe models cannot be used in high-rise stairwell applications where codes require re-entry to every fourth floor in the event of a fire, as these are fire-rated doors and the positive latching is lost in this mode. Fail-safe models can be used on non-fire-rated traffic control doors. There are many varieties of electric strikes offering varying levels of protection against forced entry. Electric strikes should be used only where the door frame or the surrounding wall structure is sufficient to prohibit access to strike components or wiring. Electric strikes should meet ANSI/BHMA A156.31 in the appropriate grade for the application and should be listed to UL 1034 for burglary-resistant electric door strikes.

Electrified Trim. Electrified trim can be used in place of electromechanical locks or electric strikes and can provide a high level of resistance to forced entry. Electric trim can be used with bored/cylindrical locks, mortise locks, or exit devices. They typically would provide keyed or electric entry. They can be used in either fail-safe or fail-secure configurations.

Deadbolts and Auxiliary Deadbolts. These products provide an added degree of security due to their longer throw and positive deadlocking. Auxiliary deadbolts are used to protect perimeter doors where not prohibited by codes requiring single motion

egress and are also used on interior doors for forced-entry resistance. The use of auxiliary deadbolts is often prohibited in conjunction with another lock when in a path of egress, as this would require two separate motions and can be confusing to a person during an emergency. Double-cylinder auxiliary deadbolts provide a high level of security, particularly when there are glass panels in the vicinity of the lock, but local codes should be checked for allowable applications. Deadbolt exit locks and deadbolt exit devices provide a higher degree of resistance to forced entry and can be used on doors requiring single-motion egress. The only deadbolts permitted on fire-rated exit doors are those that provide self-relocking. Mortise locksets that contain both a latch and deadbolt can contain single-motion release for use on doors in the path of egress and fire-rated doors. Multi-point deadbolt locks are available in a wide variety of functions and types (surface-mounted, mortise, exit device) and provide the highest level of resistance to forced entry attempts. Auxiliary deadbolts should meet ANSI/BHMA A156.5, “Deadbolt Section,” and UL 437, “Door Locks,” in the appropriate grade for the application.

Hinges. Hinges or pivots are required for all swinging doors. Hinges other than continuous hinges should be installed at intervals of every 30 in. (76.2 cm). Non-removable pins (NRP) should be used on hinges accessible from the outside (out-swinging doors). Various types of security studs are available to prevent attack. They should meet ANSI/BHMA A156.1 or ANSI/BHMA A156.26 in the appropriate grade for the application.

Door Closers and Spring Hinges. These devices will automatically close the door after opening ensuring latching or locking. They are essential for security due to the fact the door cannot latch if it is not closed. Many door closers include a “hold open” feature that will allow a door to be held in the open door position without using dangerous and inconsistent devices such as a rock, brick, or wedge to keep the door open. They should meet ANSI/BHMA A156.4 or ANSI/BHMA A156.17, “Spring Hinges,” in the appropriate grade for the application.

Doors. A door is a vulnerable point of the security of any building. The best door is of little value if there are exposed removable hinge pins, breakable vision panels, or other physical weaknesses that would allow entry. A secure door is made of metal or solid wood. Steel doors produced to ANSI/SDI A250.8 and tested to ANSI/SDI A250.4 and wood doors are tested for security. Door strength and reinforcement should be compatible with the locks used.

Non-exit doors should be installed so the hinges are on the inside to preclude removal of the screws and pins or the use of chisels or cutting devices. Exit door exterior hinges should be protected by welded, flanged, or otherwise secured pins, or hinge dowels should be used to preclude the door's removal.

An operable or glazed transom should be protected by permanently sealing it, locking it from the inside with a sturdy sliding bolt lock or other similar device, or equipping it with bars or grills.

The security measures outlined in this section are designed specifically to increase the resistance of doors to illegal entry. All doors should be secured with a locking mechanism. Consideration should be given to the structure of the opening and the surrounding wall, so that the ability to provide a secure locking device is not compromised.

Exterior doors should be of a solid-core design or steel construction with hinges on the interior of the door (in residential applications and where permitted by codes) and a keyed lock with a strike bolt into a solid frame. Frames should be fastened to the wall studs by using long screws to insure the door's stability. Strike plates should also be firmly fastened to the frame to avoid being ripped out.

Other security measures that should be considered for doors are described below.

Assuming exterior doors are of solid construction, they should be equipped with a good deadbolt with at least a 1 in. (25.4 mm) throw lock.

Exterior doors must fit tightly in the frame with no more than $\frac{1}{8}$ in. (3.2 mm) clearance between the door and frame. If the gap is too large, replace the door or install a sturdy metal strip or latch guard to the door edge to cover the gap. Deadbolts or locks with deadlocking latches help prevent entry from manipulating the bolts through the gap.

The hinged side on outward swinging doors should be protected by using non-removable hinge pins or hinges that incorporate security studs. Where practical, projecting pins that fit snugly into sockets in the door jamb when the door is closed should be installed in the hinged edge of the door. This will prevent attempts to open the door on the hinged side by removal of the hinge pin or by cutting off the hinge knuckle.

If an exterior door has a glass panel within 40 in. (101.6 cm) of the lock, replace the glass with UL-listed burglary-resisting glazing material, such as polycarbonate glazing. Alternatively, a piece of polycarbonate can be attached to the inside of the door behind the glass to provide backup protection, or the glass panel can be protected with a metal security screen. This will prevent a burglar from breaking the glass and reaching in to unlock the door.

Glass panels or inserts along with side panels should be addressed when determining the appropriate locking mechanism. Glass panels can easily be broken by intruders. Consider covering the glass with a break-resistant panel, burglary-resistant glazing, or decorative grill.

Secure exterior doors to basements, on the interior with a slide bolt, or on the exterior with a heavy-duty padlock that has a hardened steel hasp.

For doors without glazed panels, a wide-angle door viewer installed into the door provides the opportunity to view the exterior before opening the door. Door viewers meeting ANSI/BHMA A156.16 are available in three viewing angles to suit the application: Grade 1, 185 degrees; Grade 2, 145 degrees; and Grade 3, 115 degrees.

Specialty doors include those described below.

Coiling doors should be protected with slide bolts on the bottom bar unless they are controlled or locked by electric power.

An iron keeper for securing the hand chain or an iron pin for the shaft on the crank should be provided.

Solid overhead, swinging, sliding, or folding doors should be protected with a cylinder lock or padlock. A metal slide bar, bolt, or crossbar should be provided on the inside.

Metal accordion grate or grill-type doors should have a secured metal guide track at the top and bottom and be secured with a cylinder lock or padlock.

Windows.

Windows are another vulnerable point for gaining illegal access to a building. The window frame must be securely fastened to the building so that it cannot be pried loose. As with glass panels in a door, window glass can be broken or cut so the intruder can reach inside and release the lock.

Windows should be secured on the inside using a window lock, locking bolt, slide bar, or crossbar with a padlock. Under no circumstances should any window lock or bars that are installed in a premise deviate from building and fire code requirements for emergency egress.

Bars should be steel of at least $\frac{1}{2}$ in. (12.7 mm) in least dimension and spaced 6 in. (152.4 mm) apart on center. If a grille is used, the material should be at least number nine gauge 2 in. (50.8 mm) square mesh. Bars and grills must be securely fastened to the window frame so they cannot be pried loose.

Outside hinges on windows should have non-removable pins. The hinge pins should be welded, flanged, or otherwise secured so they cannot be removed.

A.8.5 Vacant areas and vacant buildings within cultural resource properties create significant security exposures to the remaining areas or building and are often especially vulnerable to vandalism, burglary, water damage, and arson. They can become hiding places for people intending to do harm to occupied areas of the property, collections, and occupants. Notification of an incident involving fire, water from broken or frozen pipes, and other problems could be delayed since no one might be present to report the problem. Thus, it is critical that the security plan include loss prevention measures to control vacant and unoccupied areas or buildings within cultural resource properties.

Loss prevention measures should include the following:

- (1) Regular checks of the perimeter and interior of the building or area
- (2) Maintenance of fire protection, alarm, heating, and electrical systems
- (3) Maintenance of exterior lighting to deter vandalism or crime
- (4) Access control of vacant areas and surrounding accessways, including alleys and driveways
- (5) Removal of trash containers and shrubbery, which might present an exposure to the building or serve as a hiding place for vandals

A.9.1 The more important general principles for fire-safe construction are set forth in this section. Detailed recommendations for good practice are also contained in various NFPA publications. In most localities, building codes and ordinances will govern the type of construction to be used.

Codes frequently provide for the safety of persons in the building, but not for the protection of the collections or the preservation of the historic fabric of the building or the collections. Therefore, it is of critical importance at the conception of the project to specify the level of protection to be achieved in the construction. It is recommended that a professional fire protection engineer be retained to participate in the development of the fire protection specifications and to verify that the specifications are fulfilled satisfactorily and similarly that a security consultant be engaged to participate in the development of security systems and to verify that security protection system specifications are adequate and properly executed.

Design of the protection systems and building construction are interrelated. For example, in addition to protecting combustible contents and providing improved safety to life, automatic fire suppression systems can offset other building and fire code requirements.

The following features of building design and engineering should be considered during construction.

- (1) Selection of materials and types of construction that are either noncombustible or fire resistant
- (2) Compartmentation of a building so that fire or smoke can be confined
- (3) Consideration of an engineered smoke management system
- (4) Selection of interior finishes and furnishings
- (5) Concepts of protection through environmental design
- (6) Access control issues — location of ingress and egress points, flow of occupants into and out of the building, potential control points, and points of vulnerability to illicit access
- (7) Vulnerability of essential utilities

For example, it is desirable to select materials and types of construction that are either noncombustible or fire resistive. Fire-resistive construction is desirable and for multistory structures is essential. Fire-resistive construction is described in the applicable building code or NFPA 220 and requires structural members, including walls, partitions, columns, floor, and roof construction, to be of noncombustible materials and to have fire resistance ratings from 2 to 4 hours, depending on the structural members. Similarly, where valuable collections will be stored, it is desirable to select materials that provide inherent resistance to forcible intrusion — such as bullet-resistant acrylic rather than glass.

The contents of a cultural resource property are valuable, sometimes of very high value or even irreplaceable, and almost always combustible. Therefore, every effort should be made to construct the building to resist the spread of fire and to provide protection for contents. This means, for example, that during a fire, the walls, roof, floor, columns, and partitions should prevent the passage of flame, smoke, or excessive heat and should continue to support their loads. “Fire resistive” is not the same as “noncombustible,” just as burglar resistant is not the same as burglar proof. For example, some materials that will not burn lose their strength when exposed to intense heat, which might cause walls or floors to collapse. Iron or steel multi-tier book stacks are an example of this type of structure. Many types of construction using various building materials have been tested and rated according to the length of time they will resist fire or intrusions. The duration of resistance needed by the library depends on the amount of combustible

material in the contents of each room as well as in the structure itself and the response time of the police or fire department.

Note that NFPA 220 classifies and defines various kinds of building construction. Testing laboratories list information on structural assemblies that have been tested in accordance with ASTM E119, *Standard Test Methods for Fire Tests of Building Construction and Materials*, or ANSI/UL 263, *Standard for Fire Tests of Building Construction and Materials*.

It is unwise to construct buildings that house cultural resource properties of materials that will contribute fuel to a fire and that, by the nature of the construction, create combustible concealed spaces, or that provide opportunities for unobserved ingress and egress. For example, voids between a ceiling and the floor above are good examples of concealed spaces through which fire can spread rapidly and where access for fire fighting is difficult, and unlocked utility closets or other accessible support areas provide an opportunity for a would-be thief to stay behind after the facility closes.

The term *compartmentation* in fire protection is used to mean subdivision of a building into relatively small areas so that water, fire, or smoke can be confined in the room or section in which it originates. Compartmentation also provides the opportunity to provide varying levels of protection for culturally significant objects, to reduce the concentration of values in any single space, and to delay access by a would-be thief. This principle can be applied to libraries and museums without restricting the flexibility of arrangement of library collections or the flow of visitors. Compartmentation requires intrusion and/or fire resistance rated wall and floor construction, with openings provided with self-closing or automatic fire doors having fire protection ratings and locking assemblies in accordance with the fire resistance and/or intrusion resistance ratings of the wall or ceiling/floor assemblies they are to protect.

In a similar way, properly enclosed stairways equipped with appropriate doors can prevent the spread of water, fire, smoke, and heat from one level to another and prevent unauthorized or illicit access to protected areas. Elevator shafts, dumbwaiters, and all other vertical openings through the structure should be similarly safeguarded. Air-handling systems (i.e., ventilation, heating, and cooling systems) should be constructed and equipped to prevent the passage of smoke, heat, and fire from one fire area to another or from one level to another as provided in NFPA 90A and to prevent unauthorized access into protected areas. For example, where the void space above the ceiling is used for an air plenum, partition walls between spaces stop at the ceiling. Where drop ceilings are used, this open space above the partition is a potential entry point for an intruder.

An engineered smoke management system should be considered as one of the means to achieve the fire safety objectives established for the cultural resource property. Depending on building construction, interior finish, and furnishings and other contents, a substantial level of smoke damage can be sustained even from a relatively small, well-controlled fire. A smoke management system should generally be considered a complement to the protection provided by automatic sprinklers or other fire suppression systems and the barriers that define the fire zones. The smoke management system can assist in limiting smoke from spreading beyond the initial fire zone. See NFPA 92 and NFPA 204.

An important consideration is the proper selection of interior finishes and furnishings. For example, highly flammable wall and ceiling finishes should be avoided. NFPA 101 and most building codes specify minimum requirements for interior finish materials. Combustible draperies should be avoided. Extra care should be used in regard to the burning characteristics of upholstered furniture, insulating materials, and acoustical materials. Careful selection of interior finishes is always important, especially in the absence of automatic fire suppression or protection.

A.9.2 This code gives both prescriptive-based and performance-based approaches to achieving its fundamental objectives. Equivalency is also included as an integral concept to achieve compliance. The code, therefore, provides a specific to guide the user in its application and to reduce possible confusion in the reading and implementation of the code.

A.9.3 An ad hoc project team that should be interdisciplinary in nature, representing security, safety, and preservation concerns should be appointed to oversee application of this code to designs for alterations, additions, renovations, or modifications to the cultural resource property. In addition, when deficiencies in protection systems are found, a project team should review corrective action plans to ensure minimal impact on culturally significant building features and collections and to ensure that planned changes provide adequate protection. Early consultation and coordination at each step of the process is highly desirable and strongly recommended. While every effort should be made to create an interdisciplinary team of players, the code recognizes that there will be times when such a diversity of members is not possible. The code, therefore, suggests but does not require any particular membership of the team. Participants on the team can include the following:

- (1) Design professionals
- (2) Fire protection professionals
- (3) Security professionals
- (4) Authorities having jurisdiction, including the following:
 - (a) Preservation officers or review agency
 - (b) Fire code officials
 - (c) Building code official or permitting authority
 - (d) Insurance company representative/broker
 - (e) Representative contractor
 - (f) Building manager
 - (g) Fire safety manager
 - (h) Building occupants
 - (i) Building owner
 - (j) Security manager

A.9.4 The survey is intended to evaluate the relevant culturally significant elements, spaces, contents, and features and relevant protection issues associated with the structure. The extent and depth of the survey might vary, depending upon the scope of the project, the cultural significance of the building and its component elements, the size and complexity of the building, changes of occupancy classification, and other factors as appropriate.

A.9.4.1.1 Character-defining features include, but are not limited to, construction materials, sheathing or façade materials, roofing materials, chimneys, skylights, cornices, windows and doors, and porches and railings.

A.9.4.1.2 Character-defining features and finishes include, but are not limited to, distinctive architectural details, wainscoting, all types of flooring, picture molding, mantels, ceiling medallions, built-in bookshelves and cabinets, crown molding, and arches, as well as simpler, more utilitarian features such as plain windows and doors and associated trim. The building survey should establish important characteristics of the building type, style, period, or historic function. The building survey should review significant spaces to establish rooms or other interior locations that are typical of the building type or style or are associated with specific persons or events.

A.9.6.2 For example, required exterior modifications or additions should be located on the less visible and least significant exterior elevations in order to keep the impact of the culturally significant structures to a minimum.

A.9.10.3.1 The selection of the method of application of the code could result from a consideration of the following:

- (1) Extent of deviation of the building from the prescriptive code
- (2) Difficulty in providing remedies in accordance with the prescriptive code
- (3) Cultural significance of the features that would be compromised by meeting the prescriptive code

The relative cost of performance-based and prescriptive-based approaches should also be considered, because this information might affect the financial means of the building owner to provide code compliance in the building. The option appraisal and selection portion of the code can function as a tool to assist in selection of a prescriptive-based or performance-based application. A building need not meet both sets of requirements.

A.9.12 The three approaches to compliance with prescriptive-based requirements — alternatives, equivalencies, and modifications — are presented in order of their legal certitude. Therefore, they should be considered in this order to minimize the need for lengthy negotiations or variance hearings. However, early conversations among interested parties can establish an acceptable level of compliance for a particular case.

A.9.12.3 Alternatives refer to options that are explicitly stated in the requirements of the prevailing code. They are often incorporated in exceptions to specific provisions. A careful reading of the prevailing code could reveal more acceptable options to the standard compliance requirements. Particular attention to alternatives should be given where jurisdictions have adopted model codes but have made exceptions for existing or historic buildings.

A.9.12.4 Equivalency refers to alternative measures of protection that can be established to provide a level of safety equivalent to the prevailing code. For example, the installation of fire detection and suppression that is not legally required in place of structurally altering the interior of a building can result in an equivalent level of protection. Less common is the compensation for a code deficiency by operational features — for example, compensating for a dead-end corridor with occupant training.

Equivalency is a common code clause that allows other means of compliance if they can be demonstrated and documented. There are many ways to address the issue of documenting equivalency, such as, in order of complexity, precedents, ad hoc equivalency, risk indexing, and component performance evaluation.

Precedents are continually established in the regulation of fire safety for cultural resource properties and historic buildings. They represent acceptable alternatives that have not been formally incorporated into a regulatory document. The annexes of this document are a unique source for identifying many of these precedents. Others might be available locally.

Ad hoc equivalency can be established by employing subjective logic. One qualitative approach used to evaluate alternative arrangements for equivalent safety is NFPA 550. The tree is a logic diagram that represents all possible means of meeting fire safety objectives. Increasing fire safety measures on one branch of the tree can offset a lack of required measures on another branch, thus establishing an arrangement of equivalent fire protection.

Fire risk indexing is a method that should be permitted to be used to establish conformance to a prevailing code. This process consists of a multi-attribute decision analysis approach to quantitatively balance variables of risk, hazard, and safety to achieve an acceptable level of fire safety. Fire risk indexing is a systematic approach to equivalency that considers the building in its entirety and produces a calculated value to identify the degree of compliance with the intent of a prescriptive code.

The following documents have an established record of meeting code objectives through an indexing approach:

- (1) NFPA 101A, Chapters 4 through 9
- (2) *Wisconsin Historic Building Code*, Subchapter IV, Building Evaluation Method, Chapter ILHR 70

Performance-based fire safety can also be approached on a component basis rather than a systematic basis. Some fire safety components already have a form of performance criteria such as fire resistance. Component performance can also be evaluated on a more ad hoc basis through the use of equivalency clauses in building codes. Codifying more component performance criteria can provide solutions for many problems. For example, establishing measurable fire safety objectives for doors, stairs, fire escapes, dead ends, exit signs, and similar features is particularly useful for dealing with these issues in existing cultural resource properties, particularly in historic buildings.

A.9.12.4.2 Any departure from prescriptive-based code should be shown through adequate documentation to provide an equivalent level of protection. The extent of documentation/analysis required to demonstrate equivalency should be commensurate with the complexity of the issue.

Equivalent solutions rely on the prescriptive code or standard as a departure point from strict compliance. Identification is made of the areas where the building deviates from the prescriptive requirement and an equivalent solution is considered for any nonconforming issue. Equivalent solutions continue to work within the framework of the prescriptive code and justify departures from the prescriptive requirements, either individually or collectively, with an alternative acceptable to the authorities having jurisdiction. The code provides extensive annex material in an effort to provide a stronger frame-

work of information to authorities having jurisdiction as they form decisions on proposed equivalent alternatives. The code also encourages the identification of still more resources to continue to support authorities having jurisdiction in their role of judging proposed alternatives. Maximum flexibility within the confines of equivalent safety is encouraged at all times.

The intent of this code is that liberal use be made of the annex material and references as a basis for establishing equivalency. These and other materials, commonly consulted to provide documentation for performance-based design approaches, also provide strong guidance and support for equivalency solutions. Other materials and information to be considered can include the identification of precedents and research findings.

Materials located in the annex sections of this code, as well as the referenced documents, can be used as sources of information to evaluate design alternatives. The application of specific information from these or other sources must be demonstrated as sound through the performance-based approach requirements described in Chapter 9. The annex and referenced sources of information are not intended to be exclusive sources of information. Any sources of information that can be demonstrated to be credible and valuable to the evaluation of the proposed design can be used in conjunction with this code.

A.9.12.5 In existing cultural resource properties, it is not always practical to strictly apply the provisions of the prevailing code. Physical limitations can require disproportionate effort or expense with little increase in life safety or property protection. In such cases, the authority having jurisdiction should be satisfied that reasonable protection is ensured.

In existing cultural resource properties, especially those classified as historic, it is intended that any condition that represents a serious threat be mitigated by application or appropriate safeguards. It is not intended to require modifications for conditions that do not represent a significant threat, even though such conditions are not literally in compliance with the prevailing code. Among the means of reasonably modifying prescriptive requirements are tolerances and waivers.

Tolerances allow for flexibility by relaxing many “magic numbers” in code requirements — for example, 50 people, 813 mm (32 in.), 1-hour fire resistance, and so forth. Reasonable dimensional tolerances should be permitted in applying prescriptive requirements to historic buildings. A 10 percent to 20 percent tolerance in prescriptive criteria might be reasonable if it allows historic preservation objectives to be achieved. In legal jargon, such tolerances are referred to as *de minimis* — that is, they are considered insignificant with respect to the overall protection of the building and/or its contents. Tolerance in strict application of installation standards can also be appropriate — for example, allowing a particularly sensitive room to remain unprotected in an otherwise fully sprinklered building.

Waivers can be another form of *de minimis* code application. Waivers can be appropriate where applying a code requirement in an existing cultural resource property is not reasonable. For example, a requirement that all exit doors need to swing outward could be unreasonable for some situations in historic buildings.

A.9.12.6 The subjects discussed in 9.12.6 are intended to be a partial listing of system features or beneficial attributes of a structure that could help compensate or offset one or more prescriptive code deficiencies. These provisions are not mandatory but should be identified when an argument is made for alternative approaches, equivalencies, or modifications to the prescriptive code requirements.

A.9.12.6(6) Filling concealed spaces with inert materials, such as mineral wool insulation or other similar fire-resistive materials, can further retard the spread of fire. Care should be taken to ensure that the introduction of fire barriers or fire stopping does not inadvertently result in a disturbance of the building's microclimate by impeding airflow, which might result in the growth of mold or fungus.

A.9.12.6(7) The U.S. Department of Housing and Urban Development has developed the "Guideline on Fire Ratings of Archaic Materials and Assemblies" to identify approximate fire resistance qualities of older construction methods. (See *NFPA 914, Annex O, Guideline on Fire Ratings of Archaic Materials and Assemblies*.)

A.9.12.6(8) Fire detection systems that can discriminate or identify any number of characteristics of fire (e.g., presence of smoke, critical temperature rise, or infrared/ultraviolet radiations) are also considered to be a compensatory feature. The detection device that offers the fastest response with respect to the type of occupancy should be a primary consideration.

A.9.12.7.1.1 The provisions of 9.12.7.1.1 do not require inherently noncombustible materials to be tested in order to be classified as noncombustible materials. [5000: A.7.1.4.1]

A.9.12.7.1.1(1) Examples of such materials include steel, concrete, masonry, and glass. [5000: A.7.1.4.1.1(1)]

A.9.12.9 Without automatic fire protection systems, fire-resistive or noncombustible construction can survive, but combustible contents in the fire compartment will not. Fire protection systems should provide for both detection and extinguishment. While these functions are separate, they can and often should be consolidated into one continuous fire protection system that detects a fire, sounds the alarm, alerts the fire service, and initiates automatic extinguishing devices. Smoke detection systems provide an opportunity for occupant action with portable fire extinguishers before fire development activates the automatic sprinkler or other fire suppression system. Careful planning permits the installation of the necessary equipment with a minimal effect on the appearance or use of the public spaces in the cultural resource facility.

Additional descriptions, applications, and limitations of the fire protection systems mentioned in this chapter are contained in Annex C, Section C.3, Glossary of Fire Protection Systems.

Planning for the fire protection equipment must also include providing and maintaining an adequate water supply to support standpipe and hose systems for fire service as well as for automatic sprinkler systems.

A vast selection of makes, models, and styles of fire protection equipment are available today to meet practically any need a cultural resource property might have. Choosing a reputable supplier and installer is a crucially important decision that a fire protection consultant can assist a library in making. In lieu of a consultant, other valuable information can usually be

obtained from the insurer, other businesses or cultural properties in the area, and the local fire department. The cultural resource property should seek to procure a system for which parts and service are readily available now and will be in the future. In addition, the fire protection equipment and system should be listed or approved.

Many states and jurisdictions now require designers and installers of fire protection systems to be licensed and certified by national boards. Prospective installers should be asked to show proof of their qualifications, as well as their experience in installing similar systems, preferably in similar occupancies. Check to see how satisfied these other businesses were with the installation and final product. Libraries generally have special concerns and needs, especially in book-stack areas, and these must be discussed in detail with the contractor prior to beginning work. A detailed construction schedule is helpful and should be worked out in advance. The staff should also be made aware of the improvements to take place and how these fire protection systems work.

Once a fire protection system is installed, it is imperative that the system be thoroughly inspected, tested, and maintained to ensure that it functions properly.

A.9.12.10 Various devices with controlled sensitivity can detect a fire condition from smoke, a critical temperature, or the rate of temperature rise. These detectors can provide the warning needed to get people safely out of the building and start fire-extinguishing systems promptly. Fire protection specialists should be consulted to determine what kinds of detectors best fit the conditions in different parts of the building. (See *Section C.3, Glossary of Fire Protection Systems*.)

The fire detection system sounds an alarm to alert the occupants. Detection systems should also transmit signals to a listed or approved central station or fire department that is staffed or attended 24 hours a day, especially in the case of an unoccupied building. Maintenance and testing of the detection system are important, particularly in any building where it is the only automatic protection system. Research on past fires have demonstrated that failures of fire detection systems have been due to three major factors: bad design, poor maintenance, and lack of testing. (See *NFPA 72 and NFPA 1221*.)

Operation of any fire detection or suppression systems or signals from their supervisory systems should cause activation of an alarm at a constantly attended location. It could also cause activation of the building alarm system as described in *NFPA 101*. The local alarm can be in the form of bells, horns, a live voice, a prerecorded message, flashing lights, or other suitable means. All alarm systems should be installed and maintained in accordance with the applicable NFPA standards. (See *NFPA 72 and NFPA 1221*.)

A.9.12.13 See Table A.9.12.13 for known advantages and potential concerns associated with various types of automatic sprinkler systems, piping materials, and types of sprinklers.

A.9.12.13.2 Standard response sprinklers employ more robust operating elements than quick-response sprinklers and can be more appropriate for use in areas where concern for inadvertent water discharge outweighs the advantages of thermal sensitivity.

Table A.9.12.13 Considerations for Automatic Sprinkler System Types and Materials

	Known Advantages	Potential Concerns
Types of Systems		
Wet pipe	Traditional high reliability systems with water under pressure in piping at all times using heat-actuated sprinklers; lowest maintenance requirements of all system types	Mechanical damage to sprinklers or piping in low-ceiling areas, overheating, and freezing can all result in discharge of water
Antifreeze	Advantages of wet pipe systems with reduced concern for freezing	Antifreeze solutions are now restricted to those that are listed for use in fire sprinkler systems due to concerns for combustibility of sprinkler spray
Dry pipe	Air or nitrogen in piping under moderate pressure 2–3 bar [(30–40 psi) nominal] protects against freezing and prevents water discharge in the event of small leaks	Reduced reliability due to increased maintenance requirements; 30% increase in water demand; air in piping with residual water can lead to premature corrosion of steel piping systems; mechanical damage to sprinklers or piping will result in water flow; water supply must be in a heated area
Preaction — single-interlock	Requires separate detection system to activate before water is introduced to piping; protects against freezing and prevents discharge of water in the event of mechanical or corrosion damage to sprinklers or piping	Reduced reliability due to dependence on separate detection system; air in piping with residual water can lead to premature corrosion of steel piping systems; significantly higher level of regular maintenance
Preaction — double-interlock	Requires both detection system and at least one sprinkler to activate before water is introduced to piping; best protection for occupancies such as freezers where water in piping can alone be a concern	Slowest system response to fires; reduced reliability due to dependence on separate detection system; air in piping with residual water can lead to premature corrosion of steel piping systems; significantly higher level of regular maintenance
Preaction — non-interlock	Water entering piping with activation of either detection system or sprinkler increases reliability over other types of preaction systems while excluding water in normal ready condition; protects against freezing	Does not provide added protection against release of water in the event of mechanical or corrosion damage to sprinklers for piping; air in piping with residual water can lead to premature corrosion of steel piping systems
Preaction — pre-primed	Requires separate detection system to activate to allow water to enter piping in excess of priming water, limiting potential discharge in the event of mechanical or corrosion damage to sprinklers or piping	Reduced reliability due to dependence on separate detection system
Deluge	Ability to quickly discharge large quantities of water appropriate for special hazards only	Activation results in water discharge throughout protected area; air in piping with residual water can lead to premature corrosion of steel piping systems
Water mist	Can provide performance similar to traditional sprinkler systems using less water; smaller pipe sizes than sprinkler systems	No standard design method available; reduced reliability due to very small nozzle orifices and greater number of required operating components; requires specialized installation; and maintenance personnel; nozzle discharge pressures higher for some systems; potential for physical damage to articles and property in close proximity to nozzles
Types of Piping Materials		
Steel — standard wall	Traditional strength and reliability	Corrosion concerns over time, especially with residual water in pipe for dry and preaction systems
Steel — thinwall	Reduced wall thickness and joining with mechanical fittings allows lower cost (wall thickness comparable to remaining wall outside fitting for traditional threaded systems)	Corrosion concerns over time, especially with residual water in pipe for dry and preaction systems; some concern that grooves placed on piping prevent complete drainage
Copper tube	Less susceptible to corrosion than steel piping systems	More expensive than steel systems; fire hazard of allowable joining methods
CPVC (chlorinated polyvinyl chloride)	Not susceptible to corrosion; clean installation and field fabrication ideal for retrofit	Compatibility concerns, especially with regard to internal, and external exposures to materials containing plasticizers or hydrocarbons; must be in strict accordance with 9.12.13.4
Stainless steel	High degree of corrosion resistance	Increased expense; corrosion concern with sprinkler seats unless stainless steel sprinklers also utilized

(continues)

Table A.9.12.13 *Continued*

	Known Advantages	Potential Concerns
Types of Sprinklers		
Standard response	Traditional strength and reliability against accidental discharge; least maintenance and lowest testing requirements;	Lack of improved performance through technological advancements in sprinkler thermal sensitivity
Quick response	Improved sensitivity allows reaction to smaller fire and increases effectiveness of available water supplies	Reduced mass of sprinkler thermal element makes it somewhat more susceptible to accidental discharge if proper care is not taken in handling and installation
Residential	Combines increased thermal sensitivity of quick-response sprinklers with high wall wetting appropriate for typical small compartments of residential occupancies	Reduced mass of sprinkler thermal element makes it somewhat more susceptible to accidental discharge if proper care is not taken in handling and installation; increased installation requirements regarding obstructions, location, etc.

A.9.12.13.3 Preaction and dry pipe sprinkler systems are more subject to corrosion than standard wet pipe systems, due to the presence of both air and moisture within the pipes. In addition to causing problems that could impair the operation of the sprinkler system and possibly result in system failures, such as preventing valves from opening, restricting water flow and pressure to the sprinklers, and clogging drops and branch lines. The higher rates of corrosion can also result in sprinkler system malfunctions such as leaks that can have a significant adverse impact on sensitive collections and cultural properties. The products of corrosion (black and orange residue made up primarily of ferric and ferrous oxides and hydroxides) that collect in the piping can cause considerable damage to artwork, historic fabric, and collections upon discharge. The corrosion in the systems can also lead to leaks and piping failures, especially at joints, along the bottom of pipes between roll grooves, and other places where moisture accumulates. Based on this, additional precautions are warranted in areas with susceptible collections or historic fabric, or where sprinkler system repairs or replacement of piping would put the building or contents at an unacceptable risk.

Prior to the 2007 edition, NFPA 13 permitted piping in systems not subject to freezing to be installed without pitch, similar to the design of wet pipe systems. This arrangement prevents piping from fully draining, increasing the rate of corrosion in steel pipe systems. The inspection and maintenance recommendations of A.9.12.13.3.3 should be followed for dry pipe and preaction systems with steel pipe installed without pitch. In addition, consideration should be given to using a continuous source of dry inert gas for pressure maintenance or to modifying preaction systems so they may be pre-primed with water.

A.9.12.13.3.1 Proper pitching is an important element in reducing the risk of corrosion. The pitch requirements included in NFPA 13 should be considered the minimum acceptable pitch. Where adequate clearance is provided to permit the system to be installed without causing interferences with structural elements or causing low points, pitches exceeding this minimum requirement such as 4 mm/m ($\frac{1}{2}$ in. per 10 ft) should be considered.

A.9.12.13.3.2.1 Due to the heightened concerns regarding the issues associated with corrosion, additional auxiliary drainage is

needed for all preaction systems regardless of whether or not the protected area is subject to freezing.

A.9.12.13.3.3 A plan to address piping corrosion should include one or more of the following:

- (1) Installation of sprinkler piping that is corrosion resistant - Galvanized steel piping is not considered corrosion resistant for the purposes of this recommendation. Galvanized coatings can corrode where water and oxygen are present inside system piping. When galvanized coatings fail, the remaining uncoated steel corrodes at an accelerated rate.
- (2) Installation of a special listed pre-primed preaction system, filled with water under normal conditions.
- (3) Use of a continuous source of dry inert gas for pressure maintenance.
- (4) Testing of the water supply for corrosivity prior to connection to the sprinkler system.
- (5) Equipping any source of compressed air used for pressure maintenance with an air dryer or nitrogen separator.
- (6) Implementation of an approved plan for maintaining and monitoring the interior conditions of the pipe at established intervals and locations, including all of the following:
 - (a) Testing water flow devices between the semiannual tests using a means that does not introduce fresh water into the system
 - (b) Drying system piping before returning systems to service after trip tests or other incidents that introduce water into system piping beyond the riser
 - (c) Inspecting for obstructions when any of the following conditions are observed:
 - i. Pinhole leaks
 - ii. Frequent operation of system air compressor(s)
 - iii. Corrosion on the outside of pipe joints, fittings, or sprinklers
 - iv. Pitting, nodules, tubercles, or carbuncles inside piping or valves
 - v. Foreign material in water during drain tests or plugging of inspector's test connection(s)
 - vi. Plugged sprinklers
 - vii. Plugged piping in sprinkler systems dismantled during building alterations

- viii. Frequent false tripping of a dry pipe valve(s) with indications of corrosion inside the valve(s)
- ix. A 50 percent increase in the time required for water to travel to the inspector's test connection after the valve trips during a full flow trip test of a dry pipe sprinkler system when compared to the original system acceptance test

These options are based on those specified by NFPA 13 for applications where water supplies are known to be corrosive. They are recommended in this code for steel dry pipe and preaction systems because the levels of corrosion found in these systems are unacceptable for cultural resource facilities. Although NFPA 13 also allows the option of treating all water that enters the system with an approved corrosion inhibitor, experience using this option has not been satisfactory in cultural resource facilities due to potential formation of external crystals on piping and potential reduction in the service life of gaskets in mechanical couplings. This code includes the additional option of using a special listed pre-primed preaction system, in which the piping is normally filled with water.

A.9.12.13.3.6 The levels of corrosion that are being found in steel dry pipe and preaction sprinkler systems are unacceptable in cultural resource facilities. Fontana and Greene defined eight forms of corrosion, which are generally accepted and used (Fontana and Greene, 1978; Roberge, 2000). The eight main forms of corrosion include: (1) uniform corrosion, (2) pitting, (3) galvanic corrosion, (4) crevice corrosion, (5) selective leaching (parting), (6) erosion corrosion, (7) environmental cracking, and (8) intergranular corrosion (Fontana and Greene, 1978). Microbiologically influenced corrosion (MIC) is included herein as a ninth form of corrosion, although it is usually a secondary factor, which accelerates or exacerbates the rate of another form of corrosion. Definitions of the different forms of corrosion are discussed as follows:

- (1) Uniform (or general) corrosion. A regular loss of a small quantity of metal over the entire area or over a large section of the total area, which is evenly distributed within a pipe(s). General thinning of the material persists until failure occurs (Fontana and Greene, 1978; Roberge, 2000; Borenstein, 1994). An example is an exposed (unpainted and uncoated) steel tank with uniform rusting over its entire surface.
- (2) Pitting. A localized form of corrosion, results in holes or cavities in the metal. Pitting is considered to be one of the more destructive forms of corrosion and is often difficult to detect. Pits can be covered or open and normally grow in the direction of gravity, e.g., at the bottom of a horizontal surface (Fontana and Greene, 1978; Roberge, 2000; Borenstein, 1994).
- (3) Galvanic corrosion. An electric potential exists between dissimilar metals in a conductive (corrosive) solution. The contact between the two materials allows electrons to transfer from one metal to the other. One metal acts as a cathode and the other as an anode. Corrosion usually occurs at the anodic metal only.
- (4) Crevice corrosion. A localized form of corrosion, occurs within crevices and other shielded areas on metal surfaces exposed to a stagnant corrosive solution. This form of corrosion usually occurs beneath gaskets, in holes, surface deposits, and in thread and groove joints. Crevice corrosion is also referred to as gasket corrosion, deposit

corrosion, and under-deposit corrosion (Fontana and Greene, 1978; Roberge, 2000).

- (5) Selective leaching. The selective removal of one element from an alloy by corrosion. A common example is dezincification (selective removal of zinc) of unstabilized brass, resulting in a porous copper structure (Fontana and Greene, 1978; Roberge, 2000).
- (6) Erosion corrosion. Corrosion resulting from the cumulative damage of electrochemical reactions and mechanical effects. Erosion corrosion is the acceleration or increase in the rate of corrosion created by the relative movement of a corrosive fluid and a metal surface. Erosion corrosion is observed as grooves, gullies, waves, rounded holes, or valleys in a metal surface (Fontana and Greene, 1978; Roberge, 2000).
- (7) Environmental cracking. An acute form of localized corrosion caused by mechanical stresses, embrittlement, or fatigue (Fontana and Greene, 1978; Roberge, 2000).
- (8) Intergranular corrosion. Corrosion caused by impurities at grain boundaries, enrichment of one alloying element, or depletion of one of the elements in the grain boundary areas. Weld decay is a form of intergranular corrosion that results from heating of the metal during the welding to within the sensitizing range (Fontana and Greene, 1978; Roberge, 2000).
- (9) Microbiologically Influenced Corrosion (MIC). Corrosion initiated or accelerated by the presence and activities of microorganisms, including bacteria and fungi. Colonies (also called bio-films and slimes) are formed on the surface of pipes among a variety of types or microbes. Microbes deposit iron, manganese, and various salts into the pipe surfaces, forming nodules, tubercles, and carbuncles. The formation of these deposits can obstruct water flow, and if the deposits are dislodged, they can block (plug) system piping, valves, and sprinklers. MIC also normally includes pitting, which can result in pinhole leaks. MIC is rarely the only form of corrosion present in a sprinkler system. MIC normally exacerbates another form of corrosion, such as general corrosion, crevice corrosion, and under-deposit corrosion (Borenstein, 1994).

A.9.12.13.4.1 It is imperative for the installer to follow the manufacturer's instructions for storage and handling of pipes and fittings awaiting installation. CPVC can become brittle; practices that are acceptable with copper or steel pipe, such as dropping bundles from waist height, may result in microfractures that can lead to leaks. CPVC is also subject to damage from environmental conditions, such as exposure to sunlight, air pollutants, and temperature extremes. Pipes and fittings should be covered by an opaque tarp when stored outdoors.

A.9.12.13.4.2 It is imperative for the installer to follow the manufacturer's installation instructions to be sure pipe joints are made up properly and to prevent clogging pipes, fittings, and sprinkler head orifices with solvent cement. Following are some of the precautions that should be taken:

- (1) Make certain that thread sealants, gasket lubricants, or fire stop materials are compatible with the CPVC pipe
- (2) Use tools specifically designed for use with plastic pipe and fittings
- (3) Use only approved solvent cements in accordance with the manufacturer's application instructions

- (4) Pipe ends should be cut square, deburred, and beveled before solvent cementing
- (5) Rotate pipe quarter turn when bottoming pipe in fitting sockets
- (6) Prevent puddling of solvent cement in pipe and fittings, and take special care to keep solvent cement out of sprinkler head orifices
- (7) Follow the manufacturer's instructions on cure times before pressure testing
- (8) Use only insulation and/or glycerin and water solutions for freeze protection
- (9) Allow for movement of the pipe due to expansion and contraction
- (10) Use only latex paint on CPVC pipe

A.9.12.13.4.3 CPVC pipe is subject to damage from improperly installed hangers, twisting, bending, and other mechanical stresses, and from being crushed by heavy objects or personnel stepping or walking on the pipe. CPVC pipe is also subject to damage from environmental conditions such as exposure to sunlight or air pollutants or from exposure to vegetable-based compounds and oils, glycol-based antifreeze, insecticides, and other chemicals, including those found in the insulation on CAT 5 communications cable. Where CPVC pipe is used, the fire safety manager should make sure sealants, gasket lubricants, or fire stop materials used during routine maintenance or for repairs or renovation projects are compatible with CPVC pipe. In addition, the fire safety manager should have a plan with adequate controls in place to prevent CPVC sprinkler piping and fittings from being exposed to mechanical damage, direct sunlight or other sources of infrared radiation, or to incompatible materials, such as communications cable draped over CPVC pipe or hung from CPVC pipe hangers, and to make sure chemicals that could be used around CPVC pipe, such as insecticides or cleaning products, are compatible with CPVC. Manufacturers publish information about the compatibility of a wide range of products and materials with CPVC, and the fire safety manager should keep current on the information.

A.9.12.15 Where standpipes and hose lines are required or installed to provide reliable and effective fire streams in the shortest possible time, they should be installed in accordance with NFPA 14 and maintained in accordance with NFPA 25. Training and skill in the use of hose streams are essential to avoid personal injury and unnecessary property damage. Occupants should not attempt to use fire hoses unless they are part of an organized fire brigade that has received training in compliance with OSHA regulations. It must be emphasized that the use of standpipe hose lines, as with the use of fire extinguishers, should not be allowed to delay the transmission of alarms to the fire department.

A.9.12.16 Portable extinguishers are important items of fire protection equipment and should be installed in accordance with NFPA 10. They permit the use of a limited quantity of extinguishing agent on a small fire at the moment someone discovers it. Therefore, they should be present in adequate numbers. The extinguisher should be of a kind intended for the class of fire anticipated. Multiclass portable extinguishers are available that remove any doubt whether the correct extinguisher is being used. Extinguishers should be properly located and inspected regularly so that they will be in working order when needed. Personnel should know their locations and be instructed in the proper use of fire extinguishers. Thought also should be given to the selection of fire extinguishers where

materials in the cultural resource property's collections are vulnerable to damage in the event of an accidental or deliberate release of particular fire extinguishing agents. For example, the powder used in multi-purpose extinguishers is difficult to remove from oil paintings or electronic equipment. (*See Annex N for information gathered in a recent literature search on the known effects of fire extinguishing agents on materials commonly found in cultural resource collections.*) It must be emphasized that the use of fire extinguishers should not be allowed to delay the transmission of alarms to the fire department.

A.9.12.17 These systems and equipment can include, but are not limited to, the following:

- (1) Infrastructure supporting the building fire protection and life safety systems within the boundaries of the project. Project infrastructure should include those systems and utilities necessary for the support and operation of the fire protection and life safety systems of the proposed project. These infrastructure items can include the following:
 - (a) Access roadways for general ingress and egress and those necessary for fire department access in accordance with local codes, standards, and policies
 - (b) Utility systems for the provisions of electric power, fuel gas, water, and waste water; communication systems; and any other utility system deemed essential to the support of the project operations
 - (c) On-site combined heat and power generation systems, electric power generation plants or systems, fuel gas storage facilities, water supply and storage facilities, and environmental or waste management systems
- (2) Fixed fire suppression and control systems
- (3) Fire alarm systems
- (4) Emergency communications systems (ECS)
- (5) Smoke control systems
- (6) The emergency power supply and emergency power supply systems serving emergency systems, legally required standby systems, and critical operations systems should be evaluated by the Fire Commissioning Agent (FCxA) for integrated testing as a stand-alone life safety system, whether or not a fire or smoke event is occurring in the building. Normal and emergency standby power systems including, but not limited to, those powering the following:
 - (a) Smoke control systems
 - (b) Stair pressurization systems
 - (c) Smoke-proof enclosure ventilation systems
 - (d) Electric driven fire pumps
 - (e) Elevator systems
 - (f) Fire suppression system controllers
- (7) Explosion prevention and control systems
- (8) Fire-resistant and smoke-resistant assemblies. Examples include, but are not limited to, floor-ceilings and roof decks, doors, windows, barriers, and walls protected by a firestop system or device for through-penetrations and membrane penetrations, and other fire and smoke control assemblies.
- (9) Systems associated with commercial cooking operations
- (10) Elevator systems

- (11) Means of egress systems and components including, but limited to, the following:
- (a) Emergency lighting and exit signs
 - (b) Major egress components, such as corridors, stairs, ramps, and so forth
 - (c) Exit path marking systems
- (12) Other systems or installations integrated or connected to a fire or life safety system, such as, but not limited to, access control, critical processes, and hazardous operations.

[4:A.1.3.1]

A.9.12.19.1 Emergency generators provide enhanced levels of protection and should be incorporated in all heritage buildings unless the reason for their omission is valid.

A.9.12.19.3 Examples are temperature and humidity control to a particular storage vault, essential data processing equipment, or critical research projects.

A.9.12.20 Wet specimen storage rooms, workshops, display shops, conservation laboratories, paint rooms, kitchens, and rooms containing central heating equipment such as boilers and furnaces are considered hazardous areas.

A.9.12.22 Annex L.6 of NFPA 780 and IEC 62305-2 provide methods for assessments to determine the need for lightning protection.

A.9.12.24.3.2 Such collections include bronze sculptures, marbles, ceramics, and minerals.

A.9.12.24.4 Compact storage systems present a severe fire challenge that requires engineering solutions specifically designed for each installation.

A.9.12.24.4.1.3 The automatic fire suppression system, the compact storage system, and the storage compartmentation features should be designed to limit fire damage in accordance with the facility's fire safety objectives (e.g., confine fire growth to the compact storage module of origin). Significant factors to consider include the number and size of the storage modules, the separation provided between the modules (end-to-end and back-to-back), and the type of materials being stored. In general, double-interlock preaction systems and dry pipe systems are inappropriate for compact storage, because of the additional delay they introduce, coupled with the delays in activation resulting from the compact storage units themselves.

Other protection features should be considered to limit the extent of the potential fire damage, including the following:

- (1) Very high density sprinkler systems
- (2) Quick-response sprinklers
- (3) Early-warning smoke detectors
- (4) Spacers between carriages or, for automated systems, automatic park mode to increase flue spaces between carriages upon activation of a fire alarm or during idle periods
- (5) Metal vertical barriers in the middle of the shelf
- (6) Open-top shelving

A.9.12.24.4.1.4(A) The system should be designed to confine fire growth to the compact storage module of origin or the shelving range of origin.

A.9.12.24.6 Smoke control systems should comply with the requirements of NFPA 92 and NFPA 204.

A.9.12.24.7(5) Seismic protection design typically includes a combination of the following:

- (1) Rack design — shelving constructed to provide the seismic strength requirements.
- (2) Bottom bracing — shelving secured to the floor with fasteners of adequate strength to resist the anticipated shear and tension forces.
- (3) Top bracing — sway bracing at the top of the racks to provide horizontal strength adequate to resist the expected seismic forces. In most cases, bracing is tied to structural members of the building to provide a path for the horizontal forces.

A.9.12.24.8 With potential fire durations of more than 8 hours, fuel loads in book stacks can range from numbers more comparable to warehouse occupancies than to business occupancies.

The emergency operations component of the protection plan should designate routes to access book stacks, means of venting smoke, and methods to reach and fight a fire at its source. The emergency operations component of the protection plan should be developed in cooperation with the local fire service.

In many libraries, the part of the building used to house books is only a shell within which the exposed (i.e., unprotected) metal book stacks are self-supporting and rise continuously through several floor levels of the building. The book stack walkways are suspended from the book stack structure with 2.12 m (7 ft) between levels or tiers. [See Figure A.9.12.24.8(a).] This results in openings between the stacks and the walkways that provide flue-like channels for the uninterrupted upward flow of air through the books from the base of the structure to the top. [See deck slit in Figure A.9.12.24.8(b).] Because fire barriers are not between levels or tiers, the entire shell enclosing the multi-tier book stack structure must be regarded as one fire compartment, and everything it contains will be at risk to any fire that develops within or spreads to that compartment. Cast-iron or steel structural members lose strength at the temperatures routinely encountered in fires. Under fire conditions, the cast-iron or steel multi-tier book stacks might collapse. For this reason, the fire service could be unable to enter the multi-tier book stack structure for manual fire fighting.

Fire growth in multi-tier book stacks is very rapid. In the unsprinklered phase of the fire tests conducted by Factory Mutual Engineering in 1959, fire spread vertically through the open deck slits in a vase-shaped pattern (e.g., spreading horizontally at each tier as it advanced vertically), reaching the fourth tier of a four-tier book stack test assembly in 9.5 minutes (see Annex L).

The requirement to install smoke barriers in all vertical openings between tiers or decks not only will restrict the spread of smoke but also help contain the smoke and heat to facilitate detection and sprinkler operation in the immediate area of the fire. Without these barriers, detectors and sprinklers could operate in areas remote from the fire before operation of these systems in the fire area. (See description of the April 29, 1986 Los Angeles Central Library fire in B.3.2.26.1.)

In new libraries, or in major renovations or modifications of existing structures, this type of book stack should be avoided. Floor assemblies should be of conventional building construction with appropriate fire resistance ratings and the book stack ranges supported by the floor assembly upon which they are placed.

A.9.12.25 Many cultural resource properties accomplish their interpretive and educational goals through permanent, temporary, and special exhibits that are changed frequently. As a result, spatial configurations, means of egress, life safety, fire protection systems, occupancy loads, exits, and fire risks can all change and potentially cause adverse effects. The facility's governing board and its fire safety manager should include review procedures for all exhibits, existing and proposed, in the facility's protection plan and fire protection procedures.

A.9.12.25.2.1.1 Areas where movable exhibit cases that display items of high significance, rarity, or value are located should be protected by approved automatic fire detection and fire suppression systems. The choice of fire sprinklers or other suppression agents and the system design should be made in consultation with the fire protection and conservation professionals to ensure an effective system that will not cause irreparable damage to the item(s) within the case.

A.9.12.25.2.2 Light attics, mechanical systems, motors, and other electrical or mechanical components should be separated from the artifact chamber by a noncombustible barrier that will not give off harmful or corrosive combustion products if the components overheat. Fiber optic light sources can provide a reasonable light source for exhibit cases.

A.9.12.25.2.3 The exhibition of flammable or highly combustible items such as nitrate film or specimens suspended in alcohol should be discouraged in favor of noncombustible reproductions.

A.9.12.25.3.1 Treated foam board, fire retardant-treated wood, textiles, and similar materials decrease fuel load created by exhibit construction.

A.9.12.25.3.2 Sulfurous products, which can be harmful to items on display, can be released from fire retardants containing ammonium sulfate when wet. A variety of metals, including copper, steel, and aluminum, might be susceptible to corrosion in contact with fire retardants. A conservator with specialized knowledge about the type of item being displayed should be consulted before using products containing fire retardants (*see Hachfeld, P., Pollutants in the Museum Environment*).

A.9.12.25.4.2 Consideration should be given to retrofitting existing exhibit electrical systems with arc-fault circuit-interrupters (AFCIs).

A.9.12.25.5.1 Exhibit components can include cases and dioramas.

A.9.12.26.2 Where feasible, paint spraying should be in a separate building.

A.9.12.26.3 Many libraries and museums have laboratories for the preservation and restoration of books, documents, and other objects of art or artifacts. Invariably, there are quantities of flammable solvents, alcohol, waxes, and other materials that ignite readily or that evolve explosive or poisonous fumes that require special attention to provide adequate general room ventilation, if not local exhaust fume hoods.

A.9.13 Section 9.13 provides requirements for the evaluation of a performance-based protection design. The evaluation process is summarized in Figure 9.2. On the left-hand side of Figure 9.2 is input from the code. The life safety and cultural resource property preservation goals have been stated in Section 4.2. The objectives necessary to achieve these goals are stated in Section 4.3, and 9.13.9, Performance Criteria, specifies the measures that are to be used to determine whether the objectives have been met.

At the top of Figure 9.2 is the input necessary to evaluate a fire-safe design. The design specifications need to include certain retained prescriptive requirements. All assumptions about the life safety design, the fire safety design, and the response of the building and its occupants to a fire must be clearly stated as indicated in 9.13.13.2. Scenarios are used to assess the adequacy of the design as specified in 9.13.16. Eight sets of initiating events are specified for performance-based fire protection designs, which the ensuing outcomes need to be satisfactory.

Appropriate methods for assessing performance are to be used per 9.13.15. Safety factors need to be applied to account for uncertainties in the assessment as stated in 9.13.22. If the resulting predicted outcomes of the scenarios are bounded by the performance criteria, the objectives have been met and the fire safety design, coupled with the goals of maintaining the culturally significant features of the building under evaluation, is considered to be in compliance with this code. A design that fails to comply can be changed and reassessed as indicated on the right-hand side of Figure 9.2.

The approval and acceptance of a fire safety design depend on the quality of the documentation of the process. The minimum documentation that needs to accompany a submission is specified by 9.13.23.

The performance option of this code establishes acceptable levels of risk to occupants of buildings and structures as addressed in Section 4.2 and evaluates the degree or extent to which the proposed designs will alter or impact the culturally significant features of the property. While the performance option of this code does contain goals, objectives, and performance criteria necessary to provide an acceptable level of risk to culturally significant collections and building features, it does not describe how to meet the goals, objectives, and performance criteria. Design and engineering analysis are needed to develop solutions that meet the provisions of this chapter. The *SFPE Engineering Guide to Performance-Based Fire Protection Analysis and Design of Buildings* provides a framework for these assessments. Other useful references include the Australian *Fire Safety Engineering Guidelines* and the British Standard BS 7974, *Application of Fire Safety Engineering Principles to the Design of Buildings*.

A.9.13.3 Qualifications should include experience, education, and credentials that demonstrate knowledgeable and responsible use of applicable models and methods.

A.9.13.4 A third-party reviewer is a person or group of persons chosen by the authority having jurisdiction to review proposed performance-based designs.

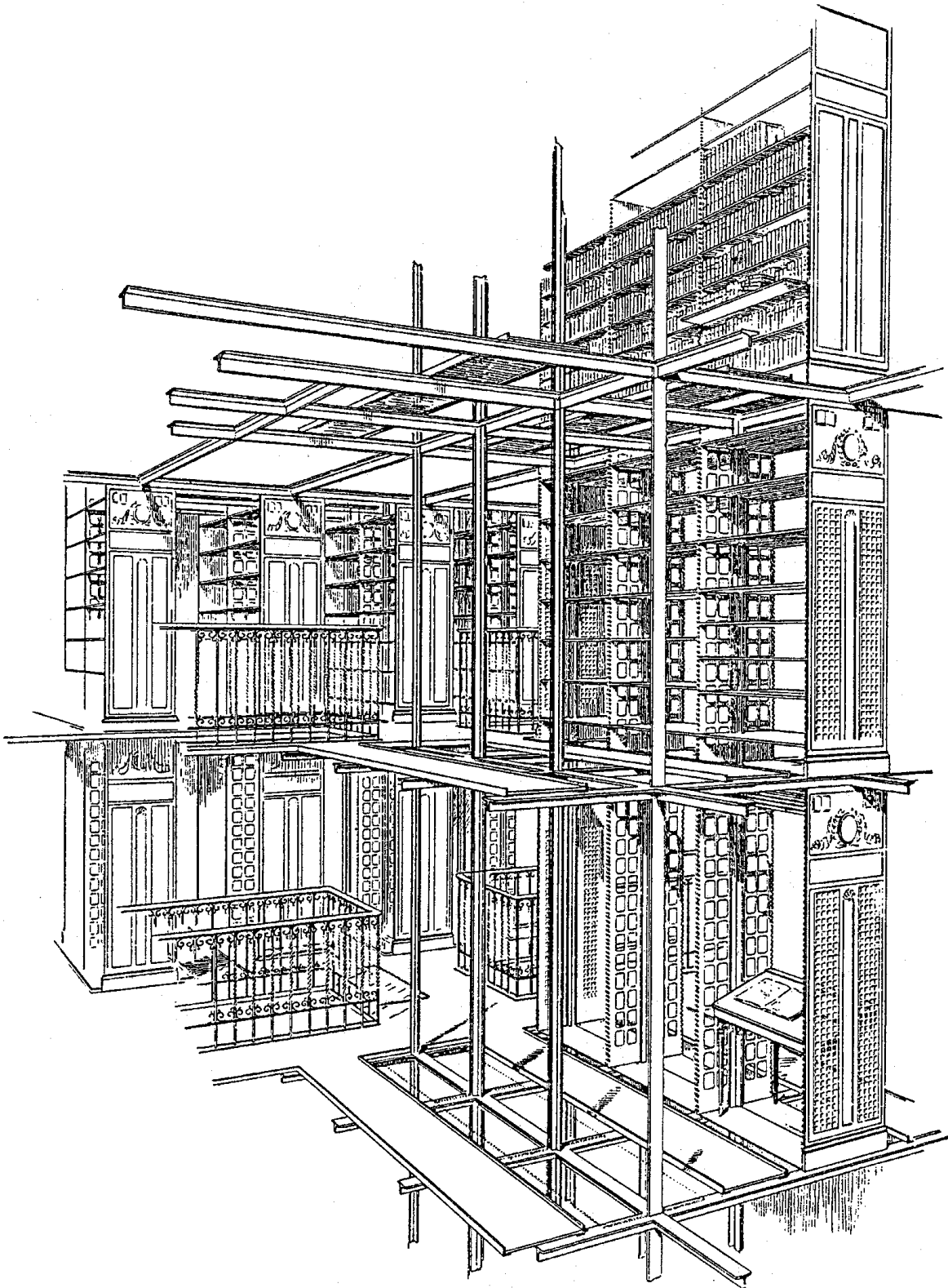

FIGURE A.9.12.24.8(a) Perspective View of Multi-tier Book Stack.

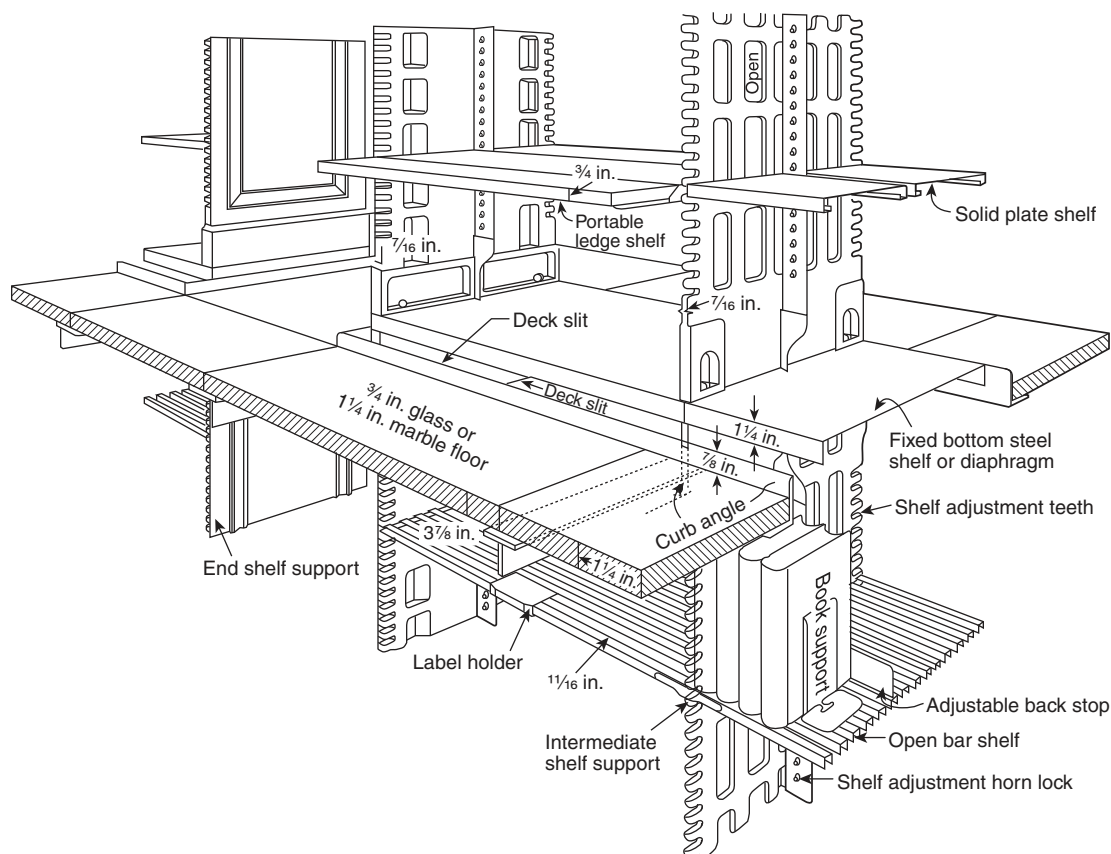

FIGURE A.9.12.24.8(b) Perspective Detail of Multi-tier Book Stack Showing Section Through Deck Flooring, Fixed Bottom Shelf, and Adjustable Shelves. (Note: For SI units, 1 in. = 25.4 mm.)

A.9.13.7 Continued compliance with the goals and objectives of the code involve many things. The building construction — including openings, interior finish, and fire- and smoke-resistant construction — and the building and fire protection system need to retain at least the same level of performance as provided for the original design parameters. Performance designs that include features that are related to management operational systems need to include specific instructions related to these features. The use and occupancy should not be allowed to change to the degree that assumptions made about the occupant characteristics, vulnerability of contents, and existence of trained personnel are no longer valid. In addition, action provided by other personnel, such as event staff or emergency responders, should not be allowed to diminish below the documented assumed levels. Also, actions needed to maintain reliability of systems at the anticipated level need to meet the initial design criteria. If such changes occur, the approach will need to be modified and the planning and design documentation amended to reflect these changes.

A.9.13.11 This evaluation should consider the use of multiple or redundant systems, features, and techniques. Prioritizing what, if any, culturally significant objects or building features are deemed acceptable to be lost to a fire needs to be evaluated and determined. The following could be potential areas of evaluation for the design team:

- (1) Set detailed performance criteria that would ensure that selected rooms or spaces are protected from flame, heat,

or smoke. The *SFPE Engineers Guide to Performance-Based Analysis and Design of Buildings* describes a process of establishing damage limits. The *SFPE Handbook of Fire Protection Engineering* also contains relevant information on thermal damage to various building materials and information on corrosivity of smoke.

- (2) Demonstrate for each design fire scenario and the design specifications, conditions, and assumptions that each room or area will be fully isolated from the conditions in that room at a level where irreversible damage can occur.
- (3) Demonstrate for each design fire scenario and the design specifications, conditions, and assumptions that conditions will not reach a level where irreversible damage can occur in any room. The advantage of this procedure is that it conservatively requires that no culturally significant item need to be exposed to harm, regardless of where the room or space is located.
- (4) Demonstrate for each design fire scenario and the design specifications, conditions, and assumptions that no fire effects will reach any room or space beyond the room of origin. An advantage of this method is that it also removes the need for some of the modeling of fire effects, because it is not necessary to model the filling of rooms, only the spread of fire effects to those rooms. This method is even more conservative and simple than the procedures in A.9.13.11(2) and A.9.13.11(3), because it does not allow any harmful effects into any room with culturally significant features.

A.9.13.13.1 The design specifications and other conditions form the input for evaluation of proposed design (*see 9.13.15*). Where a specification or condition is not known, a reasonable estimation can be made. However, the design team needs to take steps to ensure that the estimation is valid during the life of the building. Estimations need to be documented (*see 9.13.23*).

A.9.13.13.3 These characteristics should extend beyond the normal analysis of building construction features. Elements such as the type of construction, the construction technique, the use of special materials, as well as any unusual design features in the building, should also be explicitly identified.

A.9.13.13.4 Systems addressed by this requirement include automatic fire suppression systems, fire alarm systems, and electronic premises protection systems. Performance issues that need to be documented might include response time indexes, discharge densities, and distribution patterns. Calculations should not include an unlimited supply of extinguishing agents, for example, if only a limited supply is provided within the actual structure of the building.

A.9.13.13.5.1 Examples of design features that might be incorporated to modify expected occupant characteristics include training, use of staff to assist with notification and movement, or type of notification appliance used.

A.9.13.13.5.4 The four basic characteristics — sensibility, reactivity, mobility, and susceptibility — comprise a minimum, exhaustive set of mutually exclusive performance characteristics of people in buildings that can affect a fire safety system's ability to meet protection objectives. The characteristics are briefly described as follows:

- (1) Sensibility to physical cues is the ability to sense the sounding of an alarm. It can also include discernment and discrimination of visual and olfactory cues in addition to auditory emanations from the fire itself.
- (2) Reactivity is the ability to interpret cues correctly and to take appropriate action. Reactivity can be a function of cognitive capacity, speed of instinctive reaction, or group dynamics. Occupants might need to consider the reliability of a decision or the likelihood of a wrong decision, as in the influence of familiarity with the premises on finding one's way.
- (3) Mobility (speed of movement) is determined by individual capabilities as well as by crowding phenomena such as that which results from arched doorways.
- (4) Susceptibility to products of combustion can affect survivability in a fire environment. Metabolism, lung capacity, pulmonary disease, allergies, or other physical limitations, for example, influence the extent to which one is susceptible to products of combustion.

In application, as with the use of computer evacuation models, assumptions can address a larger number of factors that are components of the basic performance characteristics described in Table A.9.13.13.5.4.

A.9.13.13.5.6 The number of people expected to be in a room or area should be based on the occupant load factor specified in the officially adopted building code, fire code, or life safety code.

Table A.9.13.13.5.4 Performance Characteristics

Characteristics	Description
Alertness	Awake/asleep; can depend on time of day
Responsiveness	Ability to sense cues and react
Commitment	Degree to which occupant is committed to an activity underway before the alarm
Focal point	Point at which an occupant's attention is focused (e.g., to front of the classroom, stage, or computer)
Physical and mental capabilities	Can affectability to sense, respond, and react to cues; can be related to age or disability
Role	Can determine whether occupants will lead or follow others
Familiarity	Can depend on time spent in building or participating in emergency training
Social affiliation	Extent to which an occupant acts/reacts as an individual or as a member of a group
Condition	Over the course of the fire, the effects — both physiological and psychological — of the fire and its combustion products on each occupant

A.9.13.13.5.7 For example, in museums and libraries, staff characteristics such as number, location, quality, and frequency of training should be considered.

A.9.13.13.7 Design proposals need to state explicitly any design specifications or estimations regarding the building's protection plan, inspection programs, or other ongoing programs whose performance is necessary for the building, when occupied or operational or when closed after hours, to meet the stated goals and objectives.

A.9.13.13.9 This requirement includes assumptions about the interrelations between the performance of building elements and systems, occupant behavior, or emergency response actions that conflict with each other. For each design scenario, care needs to be taken to assure that conflicts in requirements do not occur. Typical conflicts could include the following and similar assumptions:

- (1) A fire door will remain closed during a fire event to contain smoke, while occupants use this same door during egress from the area.
- (2) A room door to a culturally significant space is closed at all times, yet the door is normally open for public viewing.
- (3) Fire apparatus will arrive immediately from a distant location to charge fire department connections to provide water.

- (4) An assumption that compartmentation blocking the passage of fire and smoke will be maintained at the door from a culturally significant space or to a stairwell cannot be paired with an assumption that evacuation through that door will extend over many minutes.

A.9.13.13.10 This requirement includes provisions that are in excess of basic requirements covered by referenced codes and standards, typical design requirements, and operating procedures. It includes provisions such as more frequent periodic testing and maintenance to increase the reliability of fire protection systems, redundant systems to increase reliability, on-site staff assistance to enhance detection of conditions or physical situations that can cause damage or loss and aid in emergency response procedures, staff training, availability and performance of emergency response personnel, and other factors.

A.9.13.14 Design fire scenarios define the challenge a building is expected to withstand. They also need to define the threat to the culturally significant features or attributes of the building. Design fire scenarios capture and limit value judgments on the type and severity of the fire challenge to which a proposed fire safety system needs to respond. The system includes any or all of the following aspects of the proposed design that are intended to mitigate the effects of a fire:

- (1) Egress capabilities
- (2) Automatic detection
- (3) Barriers
- (4) Staff training
- (5) Placement of manual extinguishers

Design fire scenarios come from two sources — those that are specified in 9.13.16.2 through 9.13.16.9 and those that are developed by the design team based on the unique characteristics of the building as required by 9.13.16.2.1. In most, if not all, cases more than one design fire scenario should be developed to meet the requirements of 9.13.16.2.1.

Once the set of design fire scenarios is established — both those specified by 9.13.16.2 through 9.13.16.9 and those that are developed as required by 9.13.16.2.1 — they must be quantified into a format that can be used for the evaluation of proposed designs. The *SFPE Engineering Guide to Performance-Based Fire Protection Analysis and Design of Buildings* outlines a process and identifies the tools and references that can be used at each step of this process.

A.9.13.15 The protection systems and features used to meet the challenge of the design fire scenario should be typical of and consistent with those used for other similar areas of the building. They should not be designed to be more effective in the building area addressed than in similar areas not included and that are, therefore, not explicitly evaluated.

A.9.13.16 It is desirable to run a wide variety of fire scenarios to evaluate the complete fire protection and life safety capabilities of the building or structure. Fire scenarios should not be limited to one or two worst-case fire scenarios.

The descriptive terms used to indicate the rate of fire growth for the scenarios are intended to be generic. Use of t-squared fires is not required for any scenarios.

A.9.13.16.2 An example of such a fire scenario for a cultural resource property would involve a church, public museum, or library. A large concentration of occupants could be present. A

significant element or feature could be immediately threatened by fire. This is a cursory example in that much of the explicitly required information indicated in 9.13.16.2 can be determined from the information provided in the example. Note that it is usually necessary to consider more than one scenario to capture the features and conditions typical of an occupancy.

A.9.13.16.3 Examples of such scenarios are a fire involving ignition of gasoline as an accelerant in a means of egress or renovation or modification materials or other fuel configurations that can cause an ultra-fast fire. The means of egress chosen is the doorway with the largest egress capacity among doorways normally used in the ordinary operation of the building. The baseline occupant characteristics for the property are assumed. Such spaces can also contain building materials or features that are culturally significant. At ignition, doors are assumed to be open throughout the building.

A.9.13.16.4 An example of such a scenario is a fire in a storage or collections room adjacent to the largest occupiable room in the building or adjacent to the room or space with the greatest cultural significance. The contents of the room of fire origin are specified to provide the largest fuel load and the most rapid growth in fire severity consistent with the normal use of the room. The adjacent occupiable room is assumed to be filled to capacity with occupants. Occupants are assumed to be somewhat impaired in whatever form is most consistent with the intended use of the building. The room contains contents that are vulnerable to minor quantities of heat or smoke. At ignition, doors from both rooms are assumed to be open. Depending upon the design, doorways might connect the two rooms or they might connect via a common hallway or corridor.

For purposes of this scenario, an occupiable room is one that could contain people (i.e., a location within a building where people are typically found).

A.9.13.16.5 An example of such a scenario is a fire originating in a concealed wall or ceiling space adjacent to a large occupied function room or a room or space containing a special collection, furniture, religious icon, or work of art. Ignition involves concealed combustibles, including wire or cable insulation and thermal or acoustical insulation. The adjacent function room is assumed to be occupied to capacity. The baseline occupant and building characteristics for the property are assumed. At ignition, doors are assumed to be open throughout the building.

A.9.13.16.6 An example of such a scenario is a cigarette fire in a trash can. The trash can is close enough to room contents to ignite more substantial fuel sources but is not close enough to any occupant to create an intimate-with-ignition situation or close enough to immediately endanger any of the culturally significant spaces or objects. If the intended use of the property involves the potential for some occupants to be incapable of movement at any time, the room of origin is chosen as the type of room likely to have such occupants, and it is filled to capacity with occupants in that condition. If the intended use of the property does not involve the potential for some occupants to be incapable of movement, the room of origin is chosen to be an assembly or function area characteristic of the use of the property, and the trash can is placed so that it is shielded from suppression systems. At ignition, doors are assumed to be open throughout the building.

A.9.13.16.7 An example of such a scenario is a fire originating in the largest fuel load of combustibles possible in normal

operation in a function or assembly room or a process/manufacturing area characteristic of the normal operation of the property. The configuration, type, and geometry of the combustibles are chosen so as to produce the most rapid and severe fire growth or smoke generation consistent with the normal operation of the property. The baseline occupant characteristics of the property are assumed. At ignition, the doors are assumed to be closed throughout the building.

This category includes everything from a big couch fire in a small lobby or museum area to a rack fire in a combustible liquids stock in an associated conservation laboratory.

A.9.13.16.8 An example of such a scenario is an exposure fire. The initiating fire is the closest and most severe fire possible, consistent with the placement and type of adjacent properties and the placement of plants and combustible adornments on the property. The baseline occupant characteristics for the property are assumed.

This category includes wildland/urban interface fires, exposure from fires originating in adjacent structures, outside storage or trash bins, and exterior wood shingle problems, where applicable.

A.9.13.16.9 This scenario addresses a set of conditions with a typical fire originating in the building with any one passive or active fire protection system or feature being ineffective. Examples in this category include unprotected openings between floors or between fire walls or fire barrier walls, rated fire doors that fail to close automatically or are blocked open, sprinkler system water supply shut-off, non-operative fire alarm system, smoke management system not operational, or automatic smoke dampers blocked open. This scenario should represent a reasonable challenge to the other building features provided by the design and presumed to be available.

The concept of a fire originating in ordinary combustibles is intentionally selected for this event. This fire, although it presents a realistic challenge to the building and the associated building systems, does not represent the worst-case scenario of the most challenging fire event for the building. Examples of fires that originate in ordinary combustibles include the following:

- (1) *Corridor of a historic museum.* Staff is assumed not to close any exhibition space or room doors upon detection of fire. The baseline occupant characteristics for the property are assumed, and the areas of viewing rooms off the corridor are assumed to be filled to capacity with visitors. At ignition all such doors in the area are not equipped with self-closing devices and are assumed to be open throughout the smoke or fire compartment.
- (2) *Large assembly room or area within the interior of the building.* The automatic suppression systems are assumed to be out of operation. The baseline occupant characteristics for the property are assumed, and the room of origin is assumed to be filled to capacity. At ignition, doors are assumed to be closed throughout the building. A specific or rare collection piece or altar is located in the room of origin.
- (3) *Unoccupied small function room adjacent to a large assembly room or area in the interior of the building.* The automatic detection systems are assumed to be out of operation. The baseline occupant characteristics for the property are assumed, the room or origin is assumed to be unoccupied, and the assembly room is assumed to be filled to

capacity. At ignition, doors are assumed to be closed throughout the building. The room is of a particular cultural significance and is vulnerable to potential damage from an undetected fire.

A.9.13.16.9.2 This paragraph applies to each active or passive fire protection system individually and requires two different types of information to be developed by analysis and approved by the authority having jurisdiction. System reliability is to be analyzed and accepted. Design performance in the absence of the system is also to be analyzed and accepted, but acceptable performance need not mean fully meeting the stated goals and objectives. It could be possible to meet fully the goals and objectives with a key system unavailable, and yet no system is totally reliable. The authority having jurisdiction will determine what level of performance is acceptable, given the very low probability (i.e., the system's unreliability probability) that this situation will occur.

A.9.13.19.4 Procedures used to develop required input data need to preserve the intended conservatism of all scenarios and assumptions. Conservatism is only one means to address the uncertainty inherent in calculations and does not remove the need to consider safety factors, sensitivity analysis, and other methods of dealing with uncertainty. The *SFPE Engineering Guide to Performance-Based Fire Protection Analysis and Design of Buildings* outlines a process for identifying and treating uncertainty.

A.9.13.20 An assessment method translates input data, which can be test specifications, parameters or variables for modeling, or other data, into output data that are measured against the performance criteria. Computer fire models, for example, should be evaluated for their predictive capability in accordance with ASTM E1355, *Standard Guide for Evaluating the Predictive Capability of Deterministic Fire Models*.

A.9.13.22 The assessment of precision required in 9.13.17.3 includes sensitivity and uncertainty analysis, which can be translated into safety factors.

The first run a model user makes should be labeled as the base case, using the nominal values of the various input parameters. However, the model user should not rely on a single run to use as the basis for any performance-based fire safety system design. Ideally, each variable of parameter that the model user made to develop the nominal input data should have multiple runs associated with it, as should combinations of key variables and parameters. Thus, a sensitivity analysis should be conducted that provides the model user with data that indicate how the response of the proposed fire safety design can also vary. The interpretation of a model's prediction can be a difficult exercise if the model user does not have knowledge of the dynamics of the hazard or human behavior.

The first thing the model user should try to determine is whether the predictions actually make sense (i.e., they do not contradict intuition or preconceived expectations). Most likely, if the results do not pass this test, an input error has been committed.

Some factors to consider in the interpretation of a model's results are as follows:

- (1) Sometimes the predictions appear to be reasonable but are, in fact, incorrect. For example, a model can predict higher temperatures farther from the fire than closer to it. The values themselves can be reasonable (e.g., not

- hotter than the fire), but they do not “flow” down the energy as expected.
- (2) A margin of safety can be developed using the results from the sensitivity analysis, which provides the possible range of when a condition is estimated to occur, in conjunction with the performance criteria.
 - (3) Safety factors and margin of safety are two concepts used to quantify the amount of uncertainty in engineering analyses. Safety factors are used to provide a margin of safety and to represent or address the gap in knowledge between the theoretically perfect model (i.e., reality) and the engineering models that can only partially represent reality.
 - (4) Safety factors can be applied to either the predicted level of a physical condition or the time that condition is predicted to occur. Thus, a physical and/or a temporal safety factor can be applied to a predicted condition. A predicted condition (i.e., parameter’s value) and the time it occurs are best represented as distributions. Ideally, a computer fire model predicts the expected or nominal value of the distribution. Safety factors are intended to represent the spread of these distributions.
 - (5) Given the uncertainty associated with data acquisition and reduction and the limitations of computer modeling, any conditions predicted by a computer model can be thought of as an expected or nominal value within a broader range. For example, an upper-layer temperature of 600°C is predicted at a given time. If the modeled scenario is then tested (i.e., in a full-scale experiment based on the computer model’s input data), the actual temperature at that given time could be 640°C to 585°C. Therefore, the temperature should be reported as 600°C (+40°C/–15°C) or as a range of 585°C to 640°C.
 - (6) Ideally, predictions are reported as nominal values, with some percentage, or as absolute value. As an example, an upper-layer temperature prediction could be reported as 600°C, $\pm 30^\circ\text{C}$ or 600°C, ± 5 percent. In this case, the physical safety factor is 0.05 (i.e., the amount by which the nominal value should be degraded and enhanced). Given the state of the art of computer fire modeling, this safety factor is very low. Physical safety factors tend to be on the order of tens of percent; 60 percent is not unheard of.
 - (7) Part of the problem with this approach is that it is difficult to state what percentage or range is appropriate. These values can be obtained when the computer model predictions are compared to test data. However, using computer fire models in design mode does not facilitate determination of the range of values, since the room being analyzed has not been built yet, and test scenarios do not necessarily depict the intended design.
 - (8) Perform a sensitivity analysis on the assumptions that affect the condition of interest. Develop a base case that uses all nominal values for input parameters. Vary the input parameters over reasonable ranges and note the variations in predicted output. The output variation can then become the basis for the physical safety factors.
 - (9) The temporal safety factor addresses the issue of when a condition is predicted and is a function of the rate at which processes are expected to occur. For example, if a condition is predicted to occur 2 minutes after the start of the fire, this time frame can be used as a nominal value. A similar process to that described for physical safety factors can also be employed to develop temporal safety factors. In this case, however, the rates (e.g., of heat release or toxic product generation) will be varied instead of absolute values (e.g., material properties).
 - (10) The margin of safety can be thought of as a reflection of societal values and can be imposed by the authority having jurisdiction. Because authorities having jurisdiction most likely will focus on the predicted time for a condition (e.g., the model predicts occupants will have 5 minutes to safely evacuate), the margin of safety will be characterized by temporal aspects and tacitly applied to the physical margin of safety.
 - (11) Because escaping the harmful effects of conditions or physical situations that can cause damage or loss (or mitigating them) is, effectively, a race, time is the parameter of choice when assessing protection system design based on computer model predictions. When an authority having jurisdiction is faced with the predicted time of untenability, a decision needs to be made regarding whether sufficient time is available to ensure the safety of culturally significant objects or building features. The authority having jurisdiction, in assessing the margin of safety, needs to determine whether time is sufficient to get everyone out safely. If the authority having jurisdiction feels that the predicted egress time is too close to the time of untenability, the authority having jurisdiction can impose an additional time that the designer needs to incorporate into the system design. In this way, the authority having jurisdiction can impose a greater margin of safety than that originally proposed by the designer.
- A.9.13.23** The *SFPE Engineering Guide to Performance-Based Fire Protection Analysis and Design of Buildings* describes the documentation that should be provided for a performance-based fire safety design.
- Proper documentation of a performance-based design is critical to the design acceptance and construction. Proper documentation also assures that all parties involved understand what is necessary for the design implementation, maintenance, and continuity of the fire protection design. If attention to detail is maintained throughout documentation, there should be little dispute during approval, construction, start-up, and use.
- Poor documentation could result in rejection of an otherwise good design, poor implementation of the design, or inadequate system maintenance and reliability, and it provides an incomplete record for future changes or if the design is forensically tested.
- A.9.13.33** Documentation for modeling for fire safety should conform to ASTM E1472, *Standard Guide for Documenting Computer Software for Fire Models*, although most, if not all, models were originally developed before this standard was promulgated.
- A.9.14** The cultural resource property is most vulnerable during periods of renovation, modification, alteration, and new construction. Additional potential threats, such as smoking by contractors; sources of ignition such as welding and cutting, temporary electrical wiring, and heating; scaffolding that provides direct exterior access to upper floors; reduced resistance to wind, snow, and rain; and potentially unstable environmental conditions, such as exposure to water, humidity, heat, and cold are introduced. Coupled with those potential threats are the security risks associated with allowing access to contractors, inspectors, and other outsiders. Incidents of vandalism,

arson, and theft increase exponentially during periods of construction. Additionally, construction activities in cultural resource properties require a higher level of supervision and oversight than standard projects because of their potential impact on the existing building, collections, and other culturally significant objects.

A.9.14.1 Demonstrated knowledge might be evidenced by experience with similar properties or submission of designs and solutions that exhibit an understanding and sensitivity to the impact of their systems on cultural resource properties. Interviews, pre-design conferences, and verified referrals or recommendations from other cultural resource properties are useful methods for identifying contractors and personnel with a true understanding of the special needs and concerns of cultural resource properties.

A.9.14.2 Prequalification of contractors and referrals can be used to find contractors experienced in dealing with culturally significant properties. Project specifications should spell out the special precautions needed for the construction activity. Job site meetings should be used to familiarize laborers as well as craftsmen with these special concerns. Curators and key staff members should take part in these meetings.

A.9.14.3 Knowledge and experience in working with cultural resource properties are critical to ensure that the contractors are sensitive to the value and damageability of the building and its collections. Criteria that can be used in determining whether a contractor is qualified to work on this type of project include the following:

- (1) Education and training in the cultural field
- (2) Experience with similar types of projects of similar size and complexity
- (3) Satisfaction of management at other institutions or cultural resource properties with the contractor's sensitivity and suitability of results
- (4) Demonstrated success in meeting time, quality, cost, and protection requirements
- (5) References from similar institutions or cultural resource properties
- (6) Proposals that demonstrate sensitivity to the special needs of the cultural resource property and its collections

A.9.14.4 See NFPA 241.

A.9.14.5 It is important to spend time at the beginning of the project to make sure that all contractors and subcontractors understand the nature of the project, special building features or collections that require protection during construction, and other curatorial concerns. A meeting also provides an opportunity for contractors and other workers to ask questions or review alternative approaches that might have an impact on other contractors or better address curatorial concerns. Participants should include all contractors, subcontractors, workers, security staff, and curatorial staff, depending on the size of the cultural resource property and the project. Based on items discussed in this meeting, a contract can be drawn up detailing security and protection requirements for the project; as an added measure each contractor or worker on the project might be asked to sign the contract.

A.9.14.6.2(6) Proper care and handling of sprinklers and other system components is critical in preventing damage or weakening that can result in accidental discharge after installation. This is especially true for the more fragile quick-response

sprinklers and those incorporating glass bulbs. The following precautions should be taken when handling sprinklers:

- (1) Store sprinklers in a cool, dry place.
- (2) Protect sprinklers during storage, transportation, and handling, and after installation.
- (3) Do not place sprinklers loose in boxes, bins, or buckets.
- (4) Leave protective caps, where provided, attached to the sprinklers until after installation.
- (5) Use designated wrench provided by the manufacturer specifically designed for the installation of each specific type of sprinkler head.
- (6) Do not use sprinkler deflector to thread sprinklers onto fittings or to torque the sprinkler into place.
- (7) Replace sprinklers that become coated with paint, drywall, or other material, rather than attempting to clean them.

A.9.14.6.3 Most fires involving construction projects are slow smoldering fires, which can be detected in their early stages by conducting a walk-through of the facility after the operations have ceased for the day. Ideally, these should be conducted every half hour for the first 2 hours, with guard service making rounds on an hourly basis thereafter.

A.9.14.9 Pre-fire plans should be updated periodically with the local fire service. For large projects, a fire safety coordinator for the site should be appointed who should ensure that all procedures, precautionary measures, and safety standards are clearly defined in writing, understood, and complied with by all personnel on the construction site.

A.9.14.11 Deliberate and malicious setting of fires is a common cause of fire incidents in the construction phase of building rehabilitation. Control of access to the property is essential in preventing arson. The practice of good housekeeping will minimize the amount of combustible material readily available to facilitate an arson fire. If a location has experienced labor management difficulties or has previously sustained a set fire or vandalism, it is established as a target for arson and additional security should be provided. Arsonists have set fires in museums, libraries, places of worship, and historic buildings with motives ranging from mindless vandalism to attempts to cover crimes such as burglary. Arsonists are usually from the outside but not always (possibly employees or volunteers with a grudge or imagined grievance).

A.9.14.11.2 A qualified person should be assigned overall responsibility for site security during the project. Hot work operations on the work site can result in a fire long after work has stopped for the day. Therefore, if security officers are assigned to the work site, officers on duty should be informed of all locations where welding operations or other hot work were performed. They should be instructed to thoroughly and carefully check each of these locations during their regular patrols of the work site and to look for evidence of smoldering.

A.9.14.13.1.2 Construction debris, dust (especially gypsum dust and the fines resulting from the sanding of drywall joint compounds), and aerosols can affect the sensitivity of smoke detectors and, in some instances, cause deleterious effects to the detector, thereby significantly reducing the expected life of the detector. [72:A.17.7.1.11]

A.9.14.13.2.2 The local fire service should verify by on-site testing whether the water supply is capable of sustaining adequate pressure and flow rates for fire-fighting operations as anticipated by their pre-fire plan for the building. Where underground

water mains are to be provided, they should be installed, tested, and placed in service prior to other construction work.

A.9.14.13.2.4 Obstructions encountered during alterations, additions, renovations, and modifications include portable sanitation facilities, construction and demolition debris, building materials, landscaping materials, shrubbery, snow, temporary construction, vehicles, and so forth.

A.9.14.13.5.2 The code official or site manager might require additional portable fire extinguishers, based on specific hazards.

A.9.14.16.5 Major fires have occurred on construction sites when temporary incandescent or halogen site lighting has come into contact with flammable material. To avoid this risk, only fluorescent temporary lighting should be used.

A.9.14.20.3 See NFPA 241.

A.9.14.22 Construction materials stored inside the building or structure should be kept to a minimum. Materials not immediately needed should be stored away from the structure to minimize fuel loading and to reduce the likelihood that excess materials will block egress routes. Where possible, equipment and materials should be stored in secured areas with a functional fire suppression system, or materials should be subdivided and stored in secured noncombustible structures. Equipment too large to be stored in the above areas should be stored in secured, fenced yard areas.

A.9.14.22.1 Storage for excess quantities of flammable and combustible liquids should be stored downgrade from the project when possible. The storage site should also be a sufficient distance away from heavy traffic areas to minimize the exposure to personnel and others.

A.9.14.23.3 If security officers are not assigned to the work site, all welding or cutting operations should stop a minimum of 3 hours before the end of the normal work day to allow sufficient time for any fire conditions to be found in areas where hot work was undertaken.

A.9.14.25.5 See NFPA 10.

A.9.14.26.1.2 See NFPA 10.

A.10.1 Trained staff and management programs are important elements in a cultural resource property's protection plan. The authority having jurisdiction and the fire safety manager and/or security manager can agree on policies, procedures, trained staff, or other management operational systems as offsets for structural or installed protection features to comply with the code.

A.10.1.1 Management operational systems can include, but are not limited to, the following:

- (1) Policies
- (2) Procedures
- (3) Trained staff
- (4) Management oversight
- (5) Access control
- (6) Other management practices and procedures acceptable to the authority having jurisdiction

A.10.3.1 A theft or an unwanted fire, even a very small one, is a threat and should be investigated thoroughly. In addition, an unwanted event is indicative of a potential flaw in the protection plan, and, as such, its origin and causes should be investi-

gated, and an evaluation of the effectiveness of the staff's response and the operation of the protection systems is vital. Finally, the cultural resource property and the appropriate investigative agency should have a detailed record of crimes or fires in the facility for analysis purposes. Often, analysis of the history of events in the facility will reveal potential flaws in the protection plan that will not be apparent in a single incident.

A.10.4.1 Operational controls are likely to include a combination of prescriptive and performance-based compliance elements and can use trained staff, written policies and procedures, or other management tools to offset prescriptive code requirements. For example, in a special exhibit that introduces an open flame device the increased risk can be offset by posting a fire watch. Similarly, security requirements for a high-value exhibit might be offset by posting additional security staff near the exhibit or limiting access to the exhibit with temporary barriers or other similar management actions.

A.10.4.2 Operational controls should consider all elements of the cultural resource property's operation, management, and mission. For example, an access control policy that prevents legitimate public access to view exhibits or to use library materials is not appropriate for the institution's educational mission; however, leaving a place of worship open and accessible to the public 24 hours a day could place the facility and its culturally significant collections at an unacceptable risk. Operational controls should strike a balance between the cultural resource property's various, sometimes conflicting, objectives.

A.10.4.3 Operational controls should be clearly defined and documented and the responsibility for accomplishing them should be assigned to specific individuals who are accountable for maintaining and enforcing them. These responsibilities should be formally assigned in writing so that there is no doubt as to responsibilities, reporting lines, and the allocation of resources.

A.11.1 Understanding, practicing, and enforcing the basic concepts and principles of fire prevention are some of the most important functions any cultural resource facility or institution can undertake. This chapter presents some of the basic precautions applicable to all types of cultural resources. Subsequent chapters devoted to museums, libraries (*see Chapter 14*), and places of worship (*see Chapter 15*) contribute additional material specific to each type of resource. Historic buildings are specifically addressed by NFPA 914. (*See NFPA 1 for comprehensive fire prevention information.*)

A.11.2.4 Where historically significant artifacts such as painted stage drops, tapestries, and antique flags are displayed in public gathering places there is a need to balance fire and life safety requirements with the preservation needs of the artifacts. Life safety standards, including NFPA 101 mandate fire-retardant treatments for fabrics that are used in gathering places, with NFPA 701 referenced as a test protocol. NFPA 701 requires a destructive burn test of a fabric sample to verify compliance with the standard; however, this action will cause permanent damage to the material and is not recommended by accepted preservation practice. Additionally, specific chemical treatments that can be applied to reduce combustibility can also result in irreversible harm to fabrics. Nonetheless, there is a need to protect artifacts and the locations in which they are housed from fire, and safeguards must be implemented for situations where artifacts are displayed in assembly spaces. These should include, but not be limited to, prohibiting open flames (e.g., candles, lamps, and smoking), avoiding the use of

heat-producing appliances such as food and beverage preparation equipment within the room, or adding a fire watch where the artifact is located. The use of cool burning lamps such as a fluorescent within the space is recommended. Temporary lights, temporary electrical devices, and temporary cables should be located not less than 1 m (36 in.) from the artifact. The placement of a combustible artifact within an assembly space should be approved by the authority having jurisdiction; however the authority having jurisdiction should consult with disciplines that have expertise in preservation and protection of artifacts before making a decision.

A.11.3 In a fire, the prevention of interior spread of flames and smoke is critical to stopping a fire from rapidly growing. The simple act of ensuring that interior doors are kept closed when a building is not occupied is a major positive fire prevention action. Part of the facility's comprehensive fire protection program should include evaluation and incorporation of procedures for ensuring that interior doors are closed wherever possible. The governing body and the authority having jurisdiction must understand the potentially dangerous conflict in allowing interior doors to remain open to facilitate interior ventilation and air movement, thereby significantly enhancing the threat of the unimpeded spread of fire and smoke through the facility.

A.11.4 A high standard of housekeeping is the most important factor in the prevention of fire. Maintaining this high standard of housekeeping is every employee's responsibility; however, it is the facility director who assumes the final responsibility for this important activity.

A.11.4.3 Expendable materials (e.g., filters, light bulbs, and refrigerant) that are directly associated with the proper operation or maintenance of equipment found in any of these rooms can be permitted. The supply of these materials should be kept to a minimum. Depending on the quantity of materials and degree of hazard either associated with the equipment or inherent in the materials themselves, the storage of these materials might be further restricted to specialized storage containers (e.g., metal cabinets or other suitable means). Coat closets or other spaces being used for both telephone and computer equipment, along with general storage, need to be evaluated for fire integrity. Enhancement of the fire compartmentation and/or the installation of fire sprinklers might be required.

A.11.4.12 Trash containers are frequently the site of deliberate fires. The intent of this section is to ensure that trash containers are sufficiently separated from the building so that a fire in the trash container will not spread to the building.

Trash containers should not be easily moved. Wheeled containers, especially those made of plastic, should be kept within a locked compound at least 10 m (30 ft) from the facility. Containers made partly or wholly of plastic should not be used anywhere within or adjacent to the facility.

A.11.5 Designated smoking areas should not include any of the following areas:

- (1) Exhibition areas or galleries
- (2) Collection areas
- (3) Any type of workstation
- (4) Laboratories
- (5) Library reading rooms
- (6) Library book stacks
- (7) Assembly areas such as classrooms, auditoriums, theaters, chapels, or large sanctuaries

- (8) Restrooms
- (9) Mechanical rooms
- (10) Receiving areas or stock rooms
- (11) Projection rooms
- (12) Electronic equipment and telecommunication rooms
- (13) Storage areas

A.11.6.1.2 Precautions addressed by NFPA 51B include, but are not limited to, the following:

- (1) A statement of the work to be undertaken and the way it is to be carried out
- (2) Availability of approved fire extinguishers adjacent to the hot work area
- (3) Stationing of a person trained in the use of fire extinguishers in the vicinity of the hot work operation for the duration of the work and for a minimum of 3 hours following the conclusion of the hot work
- (4) Periodic monitoring and inspection of the hot work area upon conclusion of the hot work operations
- (5) Relocation, covering, or shielding of all combustibles within a certain range of the work area by approved methods

A.11.11 Annex L.6 of NFPA 780 and IEC 62305-2, *Protection against lightning — Part 2: Risk management*, provide methods for assessments to determine the need for lightning protection, and Annex D of NFPA 780 provides an outline for the inspection and maintenance of lightning protection systems.

A.11.12.1 The governing body of a cultural resource property that includes archaeological sites or where collections are displayed or located outdoors in an area exposed to threat of wildland fire can obtain more information about wildland fire management in the Federal Wildland Fire Management Plan 2001 and NPS (National Park Service) Director's Order #18 Wildland Fire Management.

A.12.1 History has shown that performance reliability of fire protection systems and equipment increases where comprehensive inspection, testing, and maintenance procedures are enforced. Diligence during inspections is important.

A.12.2.3 Inspection and testing determine what maintenance actions are required to maintain the operability of fire protection systems.

A.12.3.3 Inspection and testing determine what maintenance actions are required to maintain the operability of electronic premises security systems and to ensure that the systems are providing the intended level of protection. For example, changes in exhibits or the location of individual objects can limit or eliminate the system's effectiveness.

A.12.4.2.2 The procedures should include the steps to be taken during the impairment and the risk associated with each step as it would impact the operation of the cultural resource property.

A.12.4.3.2(5) The authority having jurisdiction, the insurance carrier, the central station or alarm company monitoring impaired systems, and supervisory staff in areas of the facility affected by the impairment should be notified.

A.12.4.3.2(6) It might be necessary to post a fire watch.

A.12.4.3.2(7) The same personnel and organizations listed in A.12.4.3.2(5) should be notified.

A.12.5.1.1 The 4-hour time frame can be reduced by a contract for special exhibits. Also, the security component of the protection plan can adjust this minimum out-of-service time.

A.12.5.2.2 The procedure should include the steps to be taken during the impairment and the risk associated with each step as it would impact the operation of the cultural resource property.

A.12.5.3.2(5) The authority having jurisdiction, the insurance carrier, the central station or alarm company monitoring impaired systems, and supervisory staff in areas of the facility affected by the impairment should be notified.

A.12.5.3.2(6) It might be necessary to post additional security personnel.

A.12.5.3.2(7) The same personnel and organizations listed in A.12.5.3.2(5) should be notified.

A.12.8 Electrical systems should be maintained in accordance with NFPA 70B.

A.13.1 Special event planning should include the following considerations:

- (1) *Planning for Special Events.* Cultural resource properties generally will have a security program to deal with normal, daily activities. There are occasions, however, when these properties will be the scene of a special event, such as a musical concert, dramatic production, blockbuster exhibition, or a visit by a VIP, at which large crowds are expected. For such events, a security program should be implemented to control the crowds, maintain proper means of egress, and avoid panic in the event of an emergency. When the event takes place on public property, security is generally the responsibility of law enforcement. On private property, the governing body or those responsible for the cultural resource property are responsible for security, although the participation and cooperation of public law enforcement can be required. In addition, although a large event takes place on public property, there can be a spillover onto surrounding private property, creating unplanned for security exposures.
- (2) *Security Vulnerability Assessment.* The governing body should conduct a vulnerability assessment before the event and from that assessment develop and implement appropriate security procedures.
- (3) *Security Program.* Behind every successful event is a security and crowd control program. The key to making the program successful is planning and preparation. While a facility can have a general security and crowd control program in place, the program should be tailored to meet the needs of each specific event. In performing a security vulnerability assessment for a special event, the following sections should be reviewed for applicability and consideration.
- (4) *Security Committee.*
 - (a) If the magnitude of the special event warrants, a security committee should be established and should consist of representatives from facility management, risk management, safety, support personnel (ushers, ticket sales personnel, etc.), event promoters, and security. A security coordinator should be appointed, and all matters dealing

with security at the event should be communicated through this individual.

- (b) Meetings of the committee should be held on a regular basis to review event planning, discuss problems, and report progress. Following the full committee meeting, individual departments should meet to review their needs and requirements.
 - (c) The security committee should review experiences with prior events to determine what worked and what didn't, and what problems were experienced and how these could impact the present event.
- (5) *Statement of Purpose.* The committee should develop a statement of purpose to provide focus for the security program. An example of a statement of purpose is: "The goal of security for this event is to provide spectators or visitors, participants, and support personnel with a safe and secure environment in which to enjoy the activity, with contingencies in place to address any concerns that can arise before, during or after the event."
 - (6) *Event Planning Measures.*
 - (a) *Personnel.*
 - i. Police officers can be employed to meet security personnel needs; however, police officers can be called away, even during the event, to handle an emergency (*see Chapter 8 for guidance on security personnel*).
 - ii. Special events can also require the hiring of temporary workers to assist in handling concessions, custodial services, and other non-security tasks. Because of the short-term need for these workers, they are generally hired without undergoing any background or reference checking. One solution to this problem can be to hire temporary workers only from agencies that perform background checks.
 - iii. The type of event (rock concert, blockbuster exhibit, VIP visit, etc.) and the estimated crowd size will determine the number of crowd control personnel (security personnel, law enforcement personnel, as well as ushers and ticket takers). The event planners and/or sales personnel should keep the security committee informed on a regular basis on the latest projected attendance figures, and staffing needs should be adjusted accordingly. While there are no rules to determine the number of crowd control personnel required at an event, a review of past events can provide a benchmark for making a determination.
 - iv. The telephone number for contacting emergency medical services (EMS) personnel should be readily available for all events. At large events (crowds larger than 10,000 people), EMS personnel should be on-site. Crowd control and security personnel should be instructed on how to initiate a medical response.
 - (b) *Identification Badges.* Event staff should be provided with picture identification cards that are worn visibly at all times. These cards can also function as access control cards. Temporary staff should be

provided with temporary identification cards. These cards should be of a distinct and easily noticed color and should be worn at all times.

- (c) *Access Control.* Access control at exterior entrances and loading docks is an important consideration before and during an event. All exterior doors, except those used for visitor entrance, should be kept locked on the outside at all times. Employees should be required to enter the facility through a controlled employee entrance. Admittance can be automated through the use of an access control system.
 - (d) *Control Center.* Consideration should be given to establishing a control center to serve as a central communication point for coordination of all activities related to the event. Representatives from security, law enforcement, EMS, and facility management should be assigned to the center, which should be centrally located within the facility. Communication for security personnel can be by portable radio or other means.
 - (e) *Parking and Traffic Control.*
 - i. Parking and traffic control play integral roles in the success of an event, since delays caused by either can result in delays in crowd ingress, which could delay the start of the event. Traffic control can also greatly affect crowd egress. For events at which a large volume of cars are expected, law enforcement should be requested to provide traffic control on local roads.
 - ii. Based on the projected attendance, a determination can be made if there will be sufficient parking on the property. If on-site parking is insufficient, it might be necessary to provide satellite parking. Transportation to and from the satellite parking, and safety, security, and traffic control at the satellite parking should also be addressed.
 - iii. Close proximity parking problems can also affect emergency medical assistance procedures. Parking areas must be monitored to ensure that emergency vehicles have access to and from the facility. Also, a few vehicles parked in the wrong areas can create chaos both when guests are arriving and when they are leaving.
- (7) *Ingress and Egress.*
- (a) *General.*
 - i. Since most patrons (visitors) arrive within 20 minutes before the start of an event, staffing needs for ticket personnel and/or gate personnel are greatest during this period. Once the event starts and the ingress traffic slows, staffing levels can be reduced and personnel reassigned to patrols or elsewhere.
 - ii. In the event of an emergency, a procedure must be in place to facilitate the orderly exiting of the crowd from the facility; gate personnel should be readily contacted so they can assist in the effort. Means must be provided for guests or patrons to exit the facility throughout the event. Emergency exits should allow for the free flow of the crowd from the facility.
 - iii. If turnstiles or gates are used during crowd ingress and these same portals are used for egress, at the end of the event the turnstiles and gates should be opened to facilitate the exiting crowds. While most of the crowd will exit at the end of an event, it is common for a large portion of the crowd to begin leaving before the event ends.
 - (8) *Entry Screening.* Entry screening can range from visual inspection and bag searches of suspicious people to searches by metal detectors and hand-held wands of all people. The goal of the screening is to remove items that can turn into dangerous missiles or weapons. The history of past events (VIP visit as compared to a special exhibit) can help to determine the level of screening used. Patrons who refuse the search should be denied entry.
 - (9) *Patrols.* Security personnel should be assigned to patrol the crowd during the event. Patrols serve as the eyes and ears for the staff in the control center. Patrols should check in on a regular basis to the communication center.
 - (10) *Other Considerations.*
 - (a) *Bomb threats.* Bomb threats are often used by disgruntled employees and others to disrupt an event. They have also become the weapon of choice for terrorists. A plan should be in place for handling bomb threats as well as procedures for evacuating a facility and conducting bomb searches.
 - (b) *Public Demonstrations.* Special events also present an opportune time for groups to express their views through a public demonstration. These demonstrations can occur without any forewarning and, at times, escalate to violence. Local law enforcement should be contacted immediately at the first sign of a demonstration.
 - (c) *Handling Disturbances, Ejections, and Arrests.* Event planners should develop policies and procedures as a means of providing staff with guidelines on how to handle disturbances. Staff should also be trained regarding actions that can be taken within the limits of the law in dealing with disturbances and, in particular, in ejecting and/or arresting spectators. Event planners should request assistance from the local police in training staff on the proper procedures to follow in ejecting a spectator or making an arrest. The following are some suggested guidelines for staff to follow:
 - i. An incident report should be filed on actions taken by staff immediately after an incident has occurred.
 - ii. Staff should stay calm and speak clearly when dealing with those involved in the disturbance. They should also avoid being patronizing or aggressive, since these attitudes can lead to an escalation in the situation. Staff must keep a level head about what is taking place.
 - iii. If alcohol will be served at the event, policies should be developed and staff trained in serving alcohol and in handling intoxicated patrons.

- iv. If it appears that a fight or altercation can take place between patrons, staff should immediately call for help. Depending on the circumstance, it is generally preferred that staff waits until help arrives before attempting to quell the disturbance. If possible, staff should remain in contact with the control center throughout the disturbance.
 - v. An action staff can take in handling any disturbance is to ask the individual(s) involved to comply with policies.
 - vi. Patrons who are uncontrolled, who exhibit rowdy behavior or endanger the safety of others, or who fail to cooperate with the repeated requests of staff should be ejected from the event.
 - vii. A plan should be developed to respond to physical disturbances.
 - viii. Law enforcement should handle all ejections and arrests, since they are usually more experienced in the proper procedures to follow.
- (3) Special historic, artistic, and/or scientific processes that can be demonstrated to the public or used to recreate objects, such as the following:
 - (a) Cooking demonstrations
 - (b) Silver, gold, and pewter casting
 - (c) Blacksmithing and similar crafts demonstrations
 - (d) Artillery and weaponry demonstrations
 - (e) Historic manufacturing processes of all types
 - (f) Art demonstrations and/or classes that use flammable solvents or materials
 - (g) Glass blowing and glass molding
 - (4) Concentrations of combustible collections either on exhibit, in book stacks, or in storage, which by their very concentration can create a fire hazard through increased fire loading, as follows:
 - (a) Historic building fragments and representative parts often retained by historic properties as documentary collections. These collections, while important, can create heavy fire loading if they are not stored selectively and carefully.
 - (b) Scientific specimens stored in alcohol or other flammable liquids.
 - (c) Large quantities of combustible objects, such as historic wooden molds and patterns used to cast metal machine parts or components of an iron building (like a greenhouse). Numbering in the thousands, these items are sometimes stored in bulk containers rather than individually, which increases the fire hazard.
 - (5) Concentrations of high-value, culturally significant objects on exhibit for special exhibitions or blockbuster shows that are intended to draw large crowds over an extended period.
 - (6) Exhibit fabrication and construction areas and workshops in which combustible and flammable materials, paints, and solvents are frequently present.
 - (7) Maintenance workshops, combustible supply storage areas, boiler and mechanical equipment rooms, and other support areas.
 - (8) Controversial exhibitions or culturally significant objects that generate strong feelings both pro and con in the community.

A.14.1.4 While this chapter prescribes minimum requirements for the protection of museums, libraries, and their collections from fire, additional guidance in security, fire prevention, fire protection, and fire loss contingency planning is provided in this annex for trustees, chief librarians, museum directors, and other staff officers who are responsible for the fire safety of the building(s) and the collections therein and for the life safety of those persons who visit or work in the buildings. It emphasizes the responsibility of all such officials to protect against fire hazards in their properties by using qualified personnel and consultants to present an analysis of the fire risk embodied in the collections, building(s), and operations. This analysis should also include an assessment of the impact of the loss or interruption that a security or fire incident would impose on the facility's service to the community.

A.14.1.6 The vulnerability assessment required by 5.2.3 should evaluate those potential threats often created by museum and library operations. Such potential threats include, but are not limited to, the following:

- (1) Conservation laboratories and areas where collections are treated using a variety of combustible and flammable materials
- (2) Special types of classes of collections as follows:
 - (a) Scientific specimens stored in alcohol
 - (b) Cellulose nitrate negatives and motion picture film
 - (c) Military weaponry, arms, or artifacts that must be checked to ensure that they are not "live"
 - (d) Rare objects or specimens composed of unstable and combustible material
 - (e) Objects, the demonstration or use of which can create a potential fire hazard, such as historical electrical equipment, steam engines, forging machinery, and fireplaces
 - (f) High value and one-of-a-kind culturally significant objects
 - (g) Easily concealed items that have high intrinsic value and that could be readily sold, such as gem collections
 - (h) Collections vulnerable to environmental changes, physical damage, or other common potential threats

The facility's governing board and its fire safety manager must understand that the specific fire hazards within their cultural resource property might differ considerably from the examples given. These are offered only as examples of the types of potential threats often found in museums and libraries.

A.14.2.4 In museum and library settings where many operational activities occur simultaneously that can create fire hazards, housekeeping, maintenance, and waste and rubbish removal are all important interconnected fire prevention-related activities. The facility's governing body and its fire safety manager should ensure a high standard of housekeeping and maintenance throughout the building(s). At a minimum, the following should be included:

- (1) In exhibit construction and fabrication areas, the following precautions should be taken:
 - (a) Fire safety and prevention practices must be an integral part of daily operations in these areas.

- (b) Sawdust and combustible scrap generated during work should be collected and properly disposed of at the end of every workday.
 - (c) Combustible supplies should not be permitted to accumulate in such quantities as to create a high fuel load.
 - (d) Exhibit cases and components no longer in use should be disassembled and recycled whenever possible. Storage of unused exhibit cases and components in the building(s) should be strictly limited. Such storage contributes to fire loading in the facility.
 - (e) Only containers approved for the disposal of solvent waste rags and materials should be used for this purpose, and these should be emptied and properly disposed of at the end of each working day.
- (2) Maintenance work and support areas such as repair shops, boiler and mechanical rooms, utility closets, plumbing chases, supply rooms, and janitorial closets are often high-fire-risk areas, particularly if improperly used for the storage of combustible or flammable materials. The following precautions should be taken:
- (a) Boiler and mechanical rooms should never be used for the storage of any combustible or flammable materials or liquids.
 - (b) Plumbing and utility closets, access points, and chases should never be used for the storage of any combustible or flammable materials or liquids.
 - (c) In maintenance work and repair rooms, the following precautions should be taken:
 - i. Fire safety and prevention practices must be an integral part of daily operations in these areas.
 - ii. Sawdust and combustible scrap generated during work should be collected and properly disposed of at the end of every workday.
 - iii. Combustible supplies should not be permitted to accumulate in such quantities as to create a high fuel load.
 - iv. Only containers approved for the disposal of solvent waste rags and materials should be used, and these shall be emptied and properly disposed of at the end of each working day.
- (3) Staff offices and support areas often contain fire risks. All office and support spaces should be kept clean and the following enforced:
- (a) Personal electrical appliances such as coffee pots, hot plates, microwaves, and similar devices should be subject to inspection by the museum, the fire safety manager, and the authority having jurisdiction. Faulty appliances should be removed from the museum or library.
 - (b) Electric equipment such as coffee pots, copy machines, and other office equipment not intended or needed for continuous operation should be turned off at the end of each working day.
 - (c) Electrical outlets should not be overloaded.
 - i. Extension cords should not be used in place of electrical outlets; where additional power is required for more than temporary, very occasional use, a properly installed electrical outlet should be provided.
 - ii. Extension or power cords should never be run under carpeting, cabinets, boxes, papers, or files, or across thresholds, over doorways, or in aisle ways and egress routes.
 - (d) Office papers, files, boxes, and other combustible materials should not be permitted to accumulate on HVAC vents, ducts, fan coil units, or radiators.
 - i. Paper and other combustible materials should not be permitted to accumulate, thereby creating additional fire loading, in the museum or library.
 - ii. All materials retained as institutional and staff records should be properly stored in closed filing cabinets.
 - (e) Office supply closets and rooms should be kept clean and organized. Combustible materials should not be permitted to accumulate to such an extent that they create additional fire loading or become a fire risk.
- A.14.2.5** The following precautions should be taken in conservation laboratories and studios, and collections restoration, cleaning, and treatment areas:
- (1) Fire safety and prevention practices must be an integral part of daily operations in these areas.
 - (2) Only containers approved for the disposal of solvent waste rags and materials should be used for this purpose, and these should be emptied and properly disposed of at the end of each working day.
 - (3) Sawdust and combustible scrap generated during work should be collected and properly disposed of at the end of every workday.
 - (4) Combustible supplies should not be permitted to accumulate in such quantities as to create a high fuel load.
- A.14.2.8.1** Where feasible, paint spraying should be in a separate building.
- A.14.2.8.2** Many libraries and museums have laboratories for the preservation and restoration of books, documents, and other objects of art or artifacts. Invariably, there are quantities of flammable solvents, alcohol, waxes, and other materials that ignite readily or that evolve explosive or poisonous fumes that require special attention to provide adequate general room ventilation, if not local exhaust fume hoods.
- A.14.3** The user of this code should take into consideration measures to prevent both the intentional and/or inadvertent intrusions into the protected areas. This can be by both physical and electronic means.
- The user should perform a vulnerability assessment to determine the level of access control required. The user should also take into consideration the flow of staff from the private areas to the public areas and from public areas to the private areas.
- Depending on the situation, the access control can be a sign on the door or an access control system using biometrics. The user should consult Annex D of this code for further details on the various levels of access control systems.
- In addition to electronic access control systems, there should be in place a form of positive identification for staff, volunteers, and vendors. This would include a unique identification badge that should be exposed at all times while on duty. Staff and volunteers should be provided in-service training on this and

taught to notify security of management should an unidentified person be noticed.

Consideration should also be given to 8.3.2 and A.8.3.2.

For those areas that are not normally occupied, a supervised intrusion detection system should be installed that is armed at all times except when authorized access is made.

Consideration should also be given to the installation of a video surveillance system that is monitored at a continually occupied station and that is recorded for playback purposes.

A.14.4.1 The primary goal of this section is to separate the fuel from the ignition sources and other sources of risk. Padding, dust covers, humidity-buffering materials, and other materials having a high surface-to-mass ratio should be noncombustible or treated with an approved fire-retardant coating.

A.14.4.1.1 Smoking in museums and libraries presents not only a fire hazard but also a threat to the collections. For these reasons, smoking should be either completely prohibited with the building(s) or strictly controlled in accordance with the provisions of Section 11.5.

A.14.4.1.2 All sources of ignition should be excluded from collections storage rooms and book stacks. Fixed space heaters should be permitted only under rigidly controlled conditions, as approved by the authority having jurisdiction.

A.14.4.1.4 Museums and libraries are using more plastic-based storage containers than ever before. Plastic is used for film storage, magazine dividers, storage boxes and bins, clothing bags, and various covers. Staff should understand that the presence of plastic-based materials can increase the risk of direct and indirect damage to the building and contents and collections of a cultural resource property. Most plastic, when burned, produces thick, acrid, black products of combustion (smoke). As plastic burns, it degrades to its original petrochemical form, resulting in fire conditions similar to combustible liquid spill fires. Smoke from burning plastic can be very damaging in the area of fire origin and throughout a facility. Experience has demonstrated that plastic covers and bags have a tendency to attract smoke particles to clothing and other fabrics.

Staff should also consider the impact that plastic will have on the design of the fire protection systems protecting an area in a facility. Significant quantities of plastic will usually require higher levels of fire protection than is required with similar quantities of ordinary combustibles (e.g., paper, wood, cardboard, textiles). Consideration should be given to how smoke from a fire will be removed from the facility. Depending on the design, size, and compartmentalization of a facility, smoke removal can be easily accomplished by the local fire department using portable fans. Larger facilities, with few openings or windows to the outside, should consider ventilation system designs that will enable manually operated exhaust settings to ventilate smoke from the areas without direct openings to the outside. In these types of facilities, fire departments might not be able to evacuate smoke in a timely fashion with the equipment typically available.

A.14.4.2 Compact storage systems present a severe fire challenge that requires engineering solutions specifically designed for each installation.

A.14.4.4.1 At the present time, NFPA 40 does not specify requirements for cellulose nitrate film negatives. Cellulose

nitrate film becomes less stable as it deteriorates with age or is exposed to elevated temperature. It can ignite spontaneously, deflagrate when it ignites, and burn without atmospheric oxygen, and the smoke causes potentially fatal chemical pneumonia in persons exposed to it without respiratory protection. Because motion picture film is wound on a reel, one layer directly against another, the heat of decomposition accelerates the rate of deterioration between the layers of film. Storing each specimen in a paper sleeve or envelope retards the deterioration of still cellulose nitrate film negatives. Each specimen should be inspected at least annually to monitor deterioration.

A.14.4.4.3.1 The Society for the Preservation of Natural History Collections (SPNHC) in a publication titled *Storage of Natural History Collections: A Preventative Conservation Approach*, and the Distilled Spirits Council of the United States have fire protection guidelines that deal strictly with alcohol that provide additional information on the use of glass containers in excess of 3.8 L (1 gal). Many specimens can fit only in containers much larger than 3.8 L (1 gal) in size.

A.14.4.5 Consideration should be given to storing valuable or sensitive records and collections closer to (but not on) the floor, as fire and its by-products are more likely to damage collections closer to the ceiling, even those remote from the fire. Items subject to water damage should not be stored directly on the floor but should be skidded or raised to reduce their exposure to damage from water or flooding. NFPA 232 provides additional information on the storage and protection of archival material. In addition, consideration should be given to creating duplicate records and storing them at an off-site location.

A.14.4.7 With potential fire durations of more than 8 hours, fuel loads in book stacks can range from numbers more comparable to warehouse occupancies than to business occupancies. An emergency operations component of the protection plan should designate routes to access book stacks, means of venting smoke, and methods for reaching and fighting a fire at its source. The protection plan should be developed in cooperation with the local fire department.

A.15.1.2 This chapter prescribes minimum requirements for the protection of places of worship and their contents. Because of the special nature of places of worship, this chapter modifies and supplements existing codes and standards to apply specifically to buildings or portions of buildings with this function. It emphasizes the need for an analysis of the risks to the building(s), contents, and operations that includes an assessment of the impact of a loss or interruption on the facility's service to the community.

A.15.3.2 The vulnerability assessment required by 5.2.3 should evaluate those culturally significant materials and special potential threats often found in the operation of a place of worship. These include, but are not limited to, the following:

- (1) High-value and one-of-a-kind culturally significant objects vulnerable to environmental changes, physical damage, or other common potential threats
- (2) Culturally significant records and archives such as baptismal and marriage records
- (3) Maintenance workshops, combustible supply storage areas, boiler and mechanical equipment rooms, and other support areas
- (4) Candles and censers
- (5) Combustible decorative materials

- (6) Gasoline powered equipment, such as lawn mowers
- (7) Controversial programs or objects that generate strong feelings both pro and con in the community
- (8) Donation boxes

The governing body must understand that the culturally significant materials and specific potential threats within the facility could differ considerably from the examples given.

A.15.3.3(3) Special assistance areas can include occupancies such as Sunday schools, nurseries, and senior citizens' meeting areas.

A.15.6.2 Special attention should be given to storage areas, which often present a serious fire hazard.

A.15.10.3 This section contemplates converting a portion of the place of worship, such as a meeting hall, to a temporary homeless shelter.

A.15.10.3.3 Measures can include, but are not limited to, access control systems, physical locks, CCTV, or intrusion detection systems within the secure portions of the building.

A.15.10.4 Special precautions should be taken to minimize risks associated with combustible stage props, temporary lighting, and other special hazards introduced in conjunction with plays, festivals, tournaments, and similar productions.

Annex B Fire Experience in Cultural Properties

This annex is not a part of the requirements of this NFPA document but is included for informational purposes only.

B.1 General.

B.1.1 Fire Experience. Cultural resource properties are vulnerable to an array of fire threats. During the period 2007–2011, there was an annual average of over 1,900 fires in cultural resource properties that resulted in property damage of almost \$4 million per year. The majority of the fires (91 percent) occurred in religious and funeral properties. Overall, most (69 percent) of the fire alarm times were during hours the property was open to the public (e.g., 9 a.m.–9 p.m.). However, it was the fires that occurred while the properties were closed to the public that resulted in the largest direct property damage (77 percent).

Fires started intentionally (21 percent) and those ignited by heating equipment (13 percent) resulted in the greatest fire losses to cultural resources properties, with each responsible for \$28 million in direct property damage. Cooking equipment caused approximately 600 fires annually (30 percent) and resulted in \$7 million in direct property damage. Note that in most of the more current data, fires involving cooking equipment and smoking materials appear to be increasing in frequency. This is at least partly due to the introduction of confined structure fire incident types in version 5.0 of the National Fire Incident Reporting System (NFIRS). This change makes it easier to document fires confined to the vessel of origin, including confined cooking fires, confined chimney or flue fires, confined trash fires, and confined fuel burner or boiler fires. Thus, fires in cooking receptacles that did not extend beyond the pan, or materials burning in a trash can, would be included in this data, increasing the number of incidents shown in the tables under these two categories.

Other major causes of fires in cultural resources properties are intentional (21 percent) and heating equipment (13 percent), each resulting in \$28 million in direct property damage annually.

Note: In 1999, the Federal Emergency Management Agency (FEMA) implemented version 5.0 of NFIRS, which changed some of the cause coding used in earlier versions. Therefore, only relative comparisons can be made between leading causes of fires from data collected before 1999 and data collected after.

B.1.2 When Fire Prevention Fails. Some factors are beyond the control of even the most effective fire prevention program especially against incendiary fires, so the risk of fire in a cultural resource property is always real. When fire strikes and there is no one in the building, the integrity of the structure — design, construction, and automatic protection systems — determines the fate of the building and the collections.

B.1.3 Fire Suppression Systems.

B.1.3.1 Automatic sprinklers have proven their value in the reduction of fire losses in cultural resource institutions. They are designed to perform the following functions:

- (1) Detect fires at the point of origin
- (2) Activate the alarm system
- (3) Control or extinguish the fire
- (4) Summon fire department assistance promptly when connected directly to central station, auxiliary, proprietary supervising station, or remote supervising station fire alarm system

B.1.3.2 Some cultural resource institutions have been reluctant to install automatic sprinklers for fear of water damage to their collections. Yet in actual fires the most extensive water damage has resulted from fire department operations with hose lines. Sprinkler protection minimizes water damage by placing a relatively small amount of water directly on the fire and sounding an alarm at the same time. Automatic sprinkler systems control fire and reduce the need for a full-scale attack by the fire service. When a fire occurs in an area protected by an automatic sprinkler system, heat opens the sprinkler or sprinklers nearest the fire, and only those close enough to the fire to be heated to the operating temperature will discharge water. NFPA statistics indicate that for structure fires in buildings equipped with wet pipe sprinkler systems where sprinklers operated, 71 percent were controlled or extinguished with one sprinkler operating, 85 percent by two or fewer sprinklers operating, 90 percent by three or fewer sprinklers operating, and 93 percent of fires by four or fewer sprinklers operating. Where sprinkler systems are retrofitted into existing cultural resource properties, system specifications should call for an air test prior to the system hydrostatic test. Such tests are typically conducted at 2.8 kPa (40 psi) and can identify missing piping, improperly connected fittings, or substandard joints that might otherwise result in water damage to the property during the standard hydrostatic test. In addition, some methods of sprinkler installation require high-temperature brazing that introduces a potential source of fire ignition. Where automatic sprinklers are being retrofitted in existing collections storage areas, only mechanical methods of joining should be permitted unless collections are removed.

B.1.3.3 Special fixed systems using a gaseous agent that can be activated automatically by a suitable smoke detection system, water mist, high-expansion foam, or other fixed system extinguishing agents can provide protection for areas where high value or particularly vulnerable contents might be damaged by water. Total flooding fixed gaseous agent systems depend upon achieving and maintaining a design concentration of the agent for effective extinguishment. Openings in the fire compartment (e.g., open windows, doors, or ventilation system that continues to operate) can prevent the achievement of an effective extinguishing concentration. Where a high reliability of operation is required for protection of high-value collections, it is good engineering practice to use total flooding gaseous systems in combination with automatic sprinkler systems, rather than as an alternative. The combination of a total flooding gaseous system with an automatic sprinkler system provides a higher probability of confining fire growth to an area less than that typically covered by the operation of one sprinkler head [e.g., 9.3 m² (100 ft²)]. Total flooding gaseous systems are a reliable substitute for manual suppression in the window of time between detection and sprinkler operation. Human response (i.e., occupant manual extinguishing action) is the least reliable means of fire suppression—especially when the building is not occupied and most vulnerable.

B.2 Museums. There was an annual average of over 70 museum and art gallery fires reported to U.S. municipal fire departments in the period 2007–2011 [see Table B.2(a)]. More than half of these fires (58 percent) occurred during normal operating hours (9 a.m.–6 p.m.), but resulted in only 21 percent of direct property damage costs, while fires that occurred between midnight and 9 a.m. resulted in 79 percent of direct property damage costs [see Table B.2(b)]. Although 18 percent of fires occurred between 6 p.m. and midnight, the property damage resulting from fires occurring during this period was very low. Cooking equipment is the major cause in 43 percent of fires and resulted in 65 percent of the direct property damage costs [see Table B.2(c)] and 36 percent of fires originated in kitchen or cooking areas [see Table B.2(d)].

B.2.1 Why Museum Fires Spread. Three factors generally contribute to the spread of fires beyond their area of origin in museums: absence of sprinklers or other means of automatic suppression, lack of adequate compartmentation (or subdivision of areas) combined with a continuity of combustibles, and delayed discovery and reporting of the fire. Large, open exhibit galleries and collection storage areas, use of mobile compact storage units, and combustible collections, furnishings, and

Table B.2(a) Reported Structure Fires in Museums or Art Galleries, by Year 2007–2011

Year	Fires
2007	82
2008	70
2009	73
2010	58
2011	53

Note: These are fires reported to U.S. municipal fire departments and so exclude fires reported only to federal or state agencies or industrial fire brigades. Fires are rounded to the nearest one.

Source: National estimates based on NFIRS and NFPA survey.

Table B.2(b) Structure Fires in Museums or Art Galleries, by Alarm Time, 2007–2011 Annual Averages

Alarm Time	Fires	Direct Property Damage (in Thousands)
midnight–3 a.m.	5 (7%)	\$833 (26%)
3 a.m.–6 a.m.	4 (5%)	\$596 (19%)
6 a.m.–9 a.m.	8 (12%)	\$1,057 (33%)
9 a.m.–noon	13 (19%)	\$488 (15%)
noon–3 p.m.	14 (21%)	\$80 (3%)
3 p.m.–6 p.m.	12 (18%)	\$96 (3%)
6 p.m.–9 p.m.	8 (13%)	\$8 (0%)
9 p.m.–midnight	3 (5%)	\$5 (0%)
Total	67 (100%)	\$3,165 (100%)

Note: These are fires reported to U.S. municipal fire departments and so exclude fires reported only to federal or state agencies or industrial fire brigades. Fires are rounded to the nearest one and property damage is rounded to the nearest thousand dollars. Fires in which the area of origin was unknown or not reported were allocated proportionally among fires with known area of origin. Sums might not equal totals due to rounding errors. Property damage estimates have not been adjusted for inflation.

Source: National estimates based on NFIRS and NFPA survey.

exhibit materials are of special concern. In addition, the absence of automatic fire detection and automatic fire suppression can allow the fire to become well established, significantly increasing the likelihood of substantial losses to the building, its contents, and its collections. Detecting and suppressing a fire in the first minutes following ignition can be critical, as it frequently takes only a few minutes for a small fire to grow.

B.2.2 Illustrative Fires. The following descriptions of fires illustrate some of the more common sources of ignition, factors contributing to the prompt extinguishment or spread of the fire, and the enormity of the losses suffered when protection is not provided. It is important to note that every museum cited in B.2.2.1 through B.2.2.25 was located in close proximity to a highly trained fire department that responded promptly upon notification of the fire.

Note: The descriptions in B.2.2.1 through B.2.2.25 are from newspaper articles and other publicly available but unofficial sources; therefore, attributions of cause, estimates of damage, and other facts presented in these descriptions could be open to question. Nevertheless, the descriptions illustrate trends and contain information that can be of value in evaluating the overall fire problem in museums.

B.2.2.1 Czech National Museum, Prague, Czech Republic — February 12, 2016. Estimated loss 10M crowns (\$420,000). Some 150 firefighters extinguished a fire that broke out at about 1:30 a.m., damaging about 200 m² of the roof and attic of this monumental, 1891 building in Wenceslas Square. The building was undergoing major renovation work, so no collections were inside. The exact cause of the fire was undetermined.

Table B.2(c) Leading Major Causes of Reported Structure Fires in Museums or Art Galleries 2007–2011 Annual Averages

Leading Major Causes	Fires	Direct Property Damage (in Thousands)
Cooking equipment	29 (43%)	\$2,057 (65%)
Smoking materials	9 (14%)	\$82 (3%)
Heating equipment	9 (14%)	\$927 (29%)
Electrical distribution and lighting equipment	5 (8%)	\$0 (0%)
Intentional	5 (8%)	\$810 (26%)
Spontaneous combustion or chemical reaction	3 (5%)	\$0 (0%)
Torch, burner, or soldering iron	3 (4%)	\$0 (0%)
Playing with heat source	2 (3%)	\$935 (30%)
Shop tools or industrial equipment excluding torches, burners, and soldering irons	1 (2%)	\$1 (0%)
Candles	1 (2%)	\$7 (0%)

Note: Leading causes are pulled from several NFIRS data elements and include proportional shares of fires with unknown data. Double counting is possible. These are fires reported to U.S. municipal fire departments and so exclude fires reported only to federal or state agencies or industrial fire brigades. Fires are rounded to the nearest one and property damage is rounded to the nearest thousand dollars. Property damage estimates have not been adjusted for inflation.

Source: National estimates based on NFIRS and NFPA survey.

Table B.2(d) Reported Structure Fires in Museums or Art Galleries, by Area of Origin, 2007–2011 Annual Averages

Area of Origin	Fires	Direct Property Damage (in Thousands)
Kitchen or cooking area	24 (36%)	\$464 (15%)
Unclassified outside area	4 (6%)	\$7 (0%)
Trash or rubbish chute, area or container	3 (5%)	\$4 (0%)
Exterior roof surface	3 (4%)	\$2 (0%)
On or near highway, public way, or street	3 (4%)	\$0 (0%)
Art gallery, exhibit hall, or library	3 (4%)	\$109 (3%)
Attic or ceiling/roof assembly or concealed space	2 (3%)	\$425 (13%)
Exterior wall surface	2 (3%)	\$1 (0%)
Exterior balcony or unenclosed porch	2 (3%)	\$0 (0%)
Courtyard, terrace, or patio	2 (2%)	\$1 (0%)
Small assembly area with less than 100-person capacity	1 (2%)	\$0 (0%)
Unclassified area of origin	1 (2%)	\$0 (0%)
Wall assembly or concealed space	1 (2%)	\$35 (1%)
Unclassified function area	1 (2%)	\$61 (2%)
Interior stairway or ramp	1 (2%)	\$0 (0%)
Processing or manufacturing area, or workroom	1 (2%)	\$0 (0%)
Other known area of origin	13 (20%)	\$2,055 (65%)
Total	67 (100%)	\$3,165 (100%)

Note: These are fires reported to U.S. municipal fire departments and so exclude fires reported only to federal or state agencies or industrial fire brigades. Fires are rounded to the nearest one and property damage is rounded to the nearest thousand dollars. Fires in which the area of origin was unknown or not reported were allocated proportionally among fires with known area of origin. Sums might not equal totals due to rounding errors. Property damage estimates have not been adjusted for inflation.

Source: National estimates based on NFIRS and NFPA survey.

B.2.2.2 Cuming Museum, London, England — March 26, 2013.

Almost 120 firefighters and 20 fire engines tackled a fire that broke out at about 12:30 p.m. in the historic Old Walworth Town Hall, now housing the Cuming Museum and Newington Library. Some 30 people were evacuated from inside the building. The fire was brought under control almost five hours later. The roof was completely destroyed, and partially collapsed, and some of the steel buckled by the intense heat. Although the London fire brigade officers rescued hundreds of objects that had been on display, some 400 objects on display could not be saved, in addition to artifacts in the temporary exhibition room, and water damage to a number of objects in storage. The fire was believed to have been caused by roofers using a blow torch. Following the fire, thieves broke into the burned out museum building and stole an ornate Asian tray and some personal possessions. In March 2016, a decision was made to close the museum, resulting in the loss of four jobs.

B.2.2.3 Smithsonian National Museum of Natural History —

February 7, 2011. Estimated \$250,000 loss. Workmen modifying the museum's cooling tower ignited the combustible fill in one of the tower's cells while cutting a pipe passing through the cell wall with a torch. Although the workmen had a fire watch in place and had examined the immediate area outside of the cell to ensure combustibles were not present, the contents on the other side of cell wall were not adequately examined. Workers were not aware that the steel pipe transitioned to plastic after it passed through the cell wall. Hot slag from the torch cutting operation passed through the interior of the steel pipe, and eventually came to rest within a section of plastic piping within the cooling tower cell. The plastic piping was ignited and the fire spread to the recently installed combustible PVC fill. Workers unsuccessfully attempted to manually extinguish the fire by pouring water into the new opening they had cut into in the steel pipe. Although the fire was detected almost immediately and the fire department summoned without delay, the fire was difficult to extinguish due to restricted access for fire fighters and the combustible nature of the fill material. By the time the fire was extinguished, nearly all of the PVC fill in the cell was consumed. The fire was contained to a single cell by the noncombustible concrete construction separating each of the tower's four cells. Fortunately, there was no damage to the museum structure or the collections. The museum's cooling needs were able to be met by operating the remaining three cells until repairs were completed.

B.2.2.4 Biblical Arts Center, Dallas Texas — June 2005. Total loss. A late-morning six-alarm fire believed to be caused by arson destroyed the museum and much of its collection. Firefighters needed about five hours to bring the fire under control. The concrete, windowless building did not have an automatic fire suppression system and temperatures inside the building reached about 815°C (1500°F) during the fire. The museum director attempted unsuccessfully to fight the fire in its early stages with portable extinguishers. Everyone in the museum when the fire broke out escaped without any injuries. Among other items, a 38 m × 6 m (124 ft × 20 ft) painting by Torger Thompson, "Miracle at Pentecost," was destroyed.

B.2.2.5 Sallows Military Museum, Alliance, Nebraska — May 2005. Estimated \$250,000 loss. An arson fire caused \$250,000 damage to the Sallows Military Museum. The arsonist apparently entered the building by smashing a glass door. Fires were set in two locations in the museum. Structural damage to the museum totaled approximately \$100,000, and damage to the

collections and contents totaled approximately \$150,000. The museum's research room suffered extensive damage from smoke, water, and fire.

B.2.2.6 Millicent Museum, Millicent Australia — May 1, 2005.

Estimated \$400,000 loss. An arson fire caused approximately \$400,000 damage to an administrative building and destroyed or severely damaged an undetermined number of books, photographs, and other artifacts, including a collection of Aboriginal artifacts collected over a span of 30 years, horse-drawn carts, and farm machinery. Fire investigators determined the fire started in a rear storage area before spreading to other areas of the museum. The building was not sprinklered.

B.2.2.7 Mosaic Templars Building, Little Rock, Arkansas —

March 16, 2005. Total loss. A fire of undetermined origin that began at about 2 a.m. destroyed the Mosaic Templars building, which was undergoing an \$8.6 million renovation to become an African American heritage museum. The Little Rock fire department reported that the fire did not appear to be intentional. The building was built in 1911 as the national headquarters for the Mosaic Templars. There were no collections or archival materials in the building when the fire occurred.

B.2.2.8 Goa State Museum, Goa, India — January 11, 2005.

Partial loss. A fire of undetermined origin, but suspected to be electrical in nature, at the Goa State Museum destroyed two galleries set up by the World Wildlife Fund. No collections were damaged. The fire service received the call at 3:12 p.m. and arrived at the site of the fire 10 to 15 minutes later to find the building engulfed by fire and smoke. It took the fire service about an hour and half to extinguish the fire. The building did not have automatic fire detection or fire suppression systems installed.

B.2.2.9 Castle Museum of Saginaw County, Saginaw, Michigan —

November 20, 2004. Estimated \$500,000 loss. An arson fire caused \$500,000 damage to the building, but no collections were damaged. When the fire began there were approximately 350 people in the museum, about half of them children. No one was injured in the fire. The arsonist apparently set the blaze in this 6500 m² (70,000 ft²) museum after breaking into the basement and stealing antiques from the museum. The fire began in a locked area of the basement that required the arsonist to breach a locked door. There also was a fire in the front of the museum. During the cleanup, crews, using palm-sized dry sponges cleaned the main hall's 230 m² (2500 ft²) ceiling by hand to remove soot from the fire.

B.2.2.10 Steele County Historical Museum, Hope, North

Dakota — October 29, 2004. Partial loss. A propane leak was the likely cause of an explosion and fire that destroyed a two-story brick building on the grounds of the Steele County Historical Museum at around 7:30 p.m. Investigators said a faulty furnace apparently filled the building with propane, which somehow ignited, blowing out three walls on the second story and causing most of the building's roof to collapse. The building, which was next to the main museum, was being renovated, and most of the collections had been removed.

B.2.2.11 Yankee Air Museum at Willow Run Airport, Van

Buren Township, Michigan — October 9, 2004. Estimated \$1 million loss. A fire of undetermined origin destroyed a hangar built in 1941 that housed vintage aircraft at an airport built by Henry Ford to produce World War II bombers on assembly lines like those used at his automotive plants. The fire, which was reported at 6:28 p.m., burned out of control for

more than an hour. Aircraft parked near the hangar were not damaged. B-17, C-47, and B-25 aircraft housed in the hangar were moved out of the building before the fire reached them. The museum lost tooling, equipment, and spare parts for the aircraft, and office and display fixtures and equipment totaling well over \$1 million in replacement value, along with thousands of irreplaceable artifacts, photos, and books.

B.2.2.12 Sardine Museum, Kujukuri, Chiba, Japan — July 30, 2004. Partial loss. An explosion of undetermined origin killed one worker and severely burned another. The explosion occurred at approximately 8:50 a.m. as the facility was preparing to open. The blast opened a hole measuring 10 m² in the roof of the 8000 m² building. The museum contained tanks of sardines, models re-enacting sardine fishing scenes, and household effects from the homes of fishermen.

B.2.2.13 Yaa Asantewaa Museum, Ashanti, Ghana — July 25, 2004. Total loss. A fire of suspicious origin gutted the museum. Eyewitnesses reported that the fire started at about 12:30 a.m. The museum did not have automatic fire suppression or automatic fire detection systems, and by the time the fire service reached the building it and the museum's collection had been destroyed.

B.2.2.14 National Capital Trolley Museum, Colesville, Maryland — September 28, 2003. Estimated \$8 million loss. A fire, believed to be electrical in nature, in a storage building, next door to the museum, destroyed eight cars and much of the building, causing an \$8 million loss. Attendance reportedly dropped 25 percent after the fire because the public believed the fire crippled the museum, which actually reopened six weeks after the fire. The early morning fire burned through the roof and destroyed the trolley cars inside. Among those lost was an 1898 car that swept snow from the tracks in Washington with large brooms made of bamboo reeds. An experimental car from the 1940s and 1950s was destroyed, as was a car that once ferried passengers from Washington to the Great Falls tourist spot on the Potomac River. The wood and masonry museum building did not have an automatic fire suppression system. The museum was rebuilt with steel and protected with an automatic sprinkler system.

B.2.2.15 National Motorcycle Museum, Bickenhill, England — September 16, 2003. Estimated £20 million loss (\$32 million). A discarded cigarette is blamed for a fire that destroyed more than 400 historic motorbikes and damaged another 100. Renovation work on the museum and restoration work on the collection totaled more than £20 million. The museum did not have an automatic fire suppression system at the time of the fire; however, when the museum was restored, an automatic sprinkler system was installed.

B.2.2.16 National Museum of Natural History (Smithsonian Institution) Washington, DC — January 22, 1989. Estimated \$1000 loss. A scientist mistakenly turned on a hotplate as he left his laboratory. A smoke detector alarm was later received in the museum's control room, and a security officer was immediately dispatched to the room. In the two minutes it took for him to arrive at the lab, a single sprinkler had activated to extinguish the fire. Total loss was under \$1000.

B.2.2.17 Fort Hill-John C. Calhoun Shrine, Clemson, SC — May 30, 1988. Partial loss. Criminals used gasoline to set fire to this 185-year-old house museum to create a diversion while they burglarized a jewelry store. The museum had been equipped with a sprinkler system in 1968. Three sprinklers operated

(one outside and two inside) to extinguish this fire before the fire department arrived. Less than one percent of the museum and its contents were damaged by fire or water.

B.2.2.18 Louisiana State Museum (The Cabildo), New Orleans, LA — May 11, 1988. Estimated \$5 million loss. During exterior renovation work on one of the most historic buildings in the U.S., it is believed a torch being used to solder a copper downspout ignited the combustible felt paper or wood in the roof. The fire apparently entered the attic and burned unnoticed for some time before being detected by smoke detectors on the floor below. Notification to the fire department was not automatic and was finally made by a passerby on the street who noticed smoke. Despite heroic efforts by the fire department, the attic, third floor (which was used for collection storage), and roof were lost to fire, and there was significant smoke and water damage to the floors below. An estimated 2 million L (500,000 gal) of water were used to control this fire. The fire chief in charge stated that if the museum had been protected by a sprinkler system, only two sprinklers would probably have been necessary to control or extinguish this fire. Loss was \$5 million.

B.2.2.19 Huntington Gallery, San Marino, CA — October 17, 1985. Estimated \$1.5 million loss. While this art gallery was protected by both smoke and heat detectors, no detectors were installed in the elevator shaft where a fire of electrical origin is thought to have burned for some time before bursting out onto the first floor. Outside air eventually reached the fire source, creating a fireball that traveled 18 m to 21 m (60 ft to 70 ft) down the corridor, totally destroying a painting done in 1777. The gallery was not sprinklered. Loss was \$1.5 million.

B.2.2.20 Byer Museum of Art, Evanston, IL — December 31, 1984. Estimated \$3 million loss. A fire of electrical origin is believed to have originated between the walls on the first floor of this three-story building and apparently burned inside the walls for some time before bursting through into the museum. For an unknown reason, the smoke detection system did not operate. The fire totally destroyed the upper two floors and roof, and fire-fighting activities caused extensive water damage to the first floor. Loss was \$3 million.

B.2.2.21 Museum of Modern Art, Rio de Janeiro, Brazil — July 8, 1978. Partial loss. Watchmen discovered a fire in this concrete and glass building about 4 a.m. The museum had no automatic fire detection or suppression systems and no interior fire barriers. There also was no emergency plan. The fire probably started from either a cigarette or from defective wiring in an improvised room used for a show a few hours earlier. Fire spread through flammable ceilings and partitions, and within 30 minutes it destroyed 90 percent of the museum's permanent collection (about 1000 works of art) and the paintings borrowed for a special exhibition. It appears that the delayed alarm, the large amount of combustibles present, and lack of an automatic fire suppression system contributed to the large loss.

B.2.2.22 San Diego Aerospace Museum, San Diego, CA — February 22, 1978. Estimated \$16 million loss. The museum and the International Aerospace Hall of Fame occupied an old wood and stucco exposition building without an automatic fire detection or fire suppression system. Workers in a neighboring structure reported a fire at 8:13 p.m., apparently set by two unknown persons who were seen running away. The first fire-fighting unit arrived at 8:17 p.m., and the fire department eventually dispatched 14 units comprising 83 of its personnel,

but was unable to save the building or its contents. Loss to the building was \$15 million, and almost all of the collection, which contained 40 planes, many historic specimens and irreplaceable documents, an aviation library valued at \$1 million, and all of the portraits and memorabilia housed in the International Aerospace Hall of Fame. Only a specimen of moon rock survived, having been stored overnight in a fire-resistive safe.

B.2.2.23 National Museum of American History (Smithsonian Institution), Washington, DC — September 30, 1970. Estimated \$1 million loss. A fire reported at 5:05 a.m. destroyed a combustible computer exhibit and damaged the Hall of Numismatics. None of the historic collections of coins and stamps was damaged. The fire walls worked well, but the museum had no automatic fire suppression systems. Water used in fighting the fire caused some damage to the exhibit floor below, and smoke damaged offices and storerooms on two floors above. The cause was probably an electrical short circuit in the exhibit. Loss was over \$1 million.

B.2.2.24 Henry Ford Museum, Dearborn, MI — August 9, 1970. Estimated \$2 million loss. A fire started in a dressing room, possibly from an overheated hair curling iron. Flames quickly spread through several historic shops reconstructed of wood, and a section of agricultural and crafts displays. Excessive combustible storage behind the exhibits aided fire spread in the unsprinklered, undivided, one-story, fire-resistive main exhibit hall of which about 22,296 m² (240,000 ft²) burned. Employees kept fire doors wet with twenty-five 9.5 L (2½ gal) water extinguishers, which prevented the fire from reaching the small museum theater. Loss was over \$2 million.

B.2.2.25 Museum of Modern Art, New York City — April 15, 1958. Estimated \$700,000 loss. Workmen repainting the second floor galleries and enlarging the air conditioning system failed to observe established fire safety precautions and smoked on the job while using combustible drop cloths, and then went to lunch leaving paint cans open and stairway doors tied open for convenience in moving equipment. During the noon hour a workman saw a small fire in a drop cloth and called for help. A museum security officer brought a portable extinguisher, and they tried to put out the blaze before turning in an alarm. The fire quickly spread to the cans of paint, untreated wood scaffolding, and combustible gallery partitions, and thick smoke poured into the clustered stairwells. Finally, someone pulled the building alarm and the separate alarm with direct connections to the fire and police departments. More than 500 people in the museum had difficulty escaping, and the smoke-filled stairways and elevator shaft delayed fire-fighters in locating the fire. The fire was brought under control two hours after the alarm was activated, but not before one person was killed, 33 were injured, two major paintings were destroyed (including a Monet), and seven paintings were severely damaged. Property loss was \$700,000.

B.3 Library Fires. There was an annual average of over 100 library fires reported to U.S. municipal fire departments in the period 2007–2011 [see Table B.3(a)]. Most of these fires (88 percent) occurred during normal operating hours (9 a.m.–9 p.m.) but resulted in only 24 percent of direct property damage costs, while fires that occurred between midnight and 3 a.m. resulted in 64 percent of direct property damage costs [see Table B.3(b)]. Intentionally set fires are the most common cause of library fires and result in the highest direct property damage costs [see Table B.3(c)]. Fires that originate in a lavatory, bathroom, locker room, check room, records storage room, or

vault typically have higher direct property damage cost [see Table B.3(d)].

B.3.1 Why Library Fires Spread. The most destructive fires in libraries have been incendiary fires where lack of compartmentation, delayed discovery and reporting, and the absence of automatic suppression or detection systems were common factors. In the absence of automatic fire detection and automatic fire suppression systems, the high fuel loads and continuity of combustibles in libraries can lead to severe, even catastrophic, losses when fires occur in book stacks. Some typical fires involving one or more of these factors are listed in B.3.2.1 through B.3.2.38, including three that tested the resources of three of the largest cities in the United States — Los Angeles, CA; New York, NY; and San Diego, CA.

Table B.3(a) Reported Library Structure Fires, by Year, 2007–2011

Year	Fires
2007	113
2008	122
2009	103
2010	100
2011	100

Note: These are fires reported to U.S. municipal fire departments and so exclude fires reported only to federal or state agencies or industrial fire brigades. Fires are rounded to the nearest one.

Source: National estimates based on NFIRS and NFPA survey.

Table B.3(b) Library Structure Fires, by Alarm Time, 2007–2011 Annual Averages

Alarm Time	Fires	Direct Property Damage (in Thousands)
midnight–3 a.m.	3 (3%)	\$332 (64%)
3 a.m.–6 a.m.	2 (2%)	\$8 (2%)
6 a.m.–9 a.m.	8 (7%)	\$14 (3%)
9 a.m.–noon	18 (17%)	\$23 (5%)
noon–3 p.m.	29 (27%)	\$12 (2%)
3 p.m.–6 p.m.	23 (21%)	\$13 (3%)
6 a.m.–9 p.m.	17 (16%)	\$77 (15%)
9 p.m.–midnight	7 (6%)	\$36 (7%)
Total	107 (100%)	\$516 (100%)

Note: These are fires reported to U.S. municipal fire departments and so exclude fires reported only to federal or state agencies or industrial fire brigades. Fires are rounded to the nearest one and property damage is rounded to the nearest thousand dollars. Sums might not equal totals due to rounding errors. Property damage estimates have not been adjusted for inflation.

Source: National estimates based on NFIRS and NFPA survey.

Table B.3(c) Leading Major Causes of Reported Library Structure Fires, 2007–2011 Annual Averages

Leading Major Causes	Fires	Direct Property Damage (in Thousands)
Intentional	40 (38%)	\$173 (34%)
Cooking equipment	28 (26%)	\$9 (2%)
Playing with heat source	14 (13%)	\$53 (10%)
Heating equipment	11 (10%)	\$52 (10%)
Smoking materials	10 (10%)	\$0 (0%)
Ventilation or cooling equipment	9 (9%)	\$39 (8%)
Electrical distribution and lighting equipment	7 (6%)	\$64 (12%)

Note: Leading causes are pulled from several NFIRS data elements and include proportional shares of fires with unknown data. Double counting is possible. These are fires reported to U.S. municipal fire departments and so exclude fires reported only to federal or state agencies or industrial fire brigades. Fires are rounded to the nearest one and property damage is rounded to the nearest thousand dollars. Property damage estimates have not been adjusted for inflation.

Source: National estimates based on NFIRS and NFPA survey.

B.3.2 Illustrative Fires. The examples in B.3.2.1 through B.3.2.38 illustrate the many ways library fires have started and spread and the destruction they have caused. In these fires alone, tens of millions of valuable books, recordings, and other library collections have needlessly been lost to fire. Damage has been directly proportional to the promptness of discovery, the transmission of an alarm, the availability of automatic fire suppression, and the concentration of combustibles in the fire area. Even the most proficient fire departments are unable to prevent losses such as those experienced during fires at the Jewish Theological Seminary Library, the Klein Law Library, and the Los Angeles Central Public Library in the absence of suitable fire detection and fire suppression systems.

Note: The descriptions in B.3.2.1 through B.3.2.38 are from newspaper articles and other publicly available but unofficial sources; therefore, attributions of cause, estimates of damage, and other facts presented in these descriptions might be open to question. Nevertheless, the descriptions illustrate trends and contain information that can be of value in evaluating the overall fire problem in libraries.

B.3.2.1 Glasgow School of Art Library, Glasgow, Scotland — May 23, 2014. Total loss. Fire broke out in this listed iconic building just before 12:30 p.m., starting in the basement, and quickly spreading upward through the entire five floors. Although the fire was brought under control quite quickly, significant damage was done to the historic studios and stairways, and the renowned Mackintosh library was destroyed. The

Table B.3(d) Reported Library Structure Fires, by Area of Origin, 2007–2011 Annual Averages

Area of Origin	Fires	Direct Property Damage (in Thousands)
Lavatory, bathroom, locker room, or check room	29 (27%)	\$36 (7%)
Kitchen or cooking area	16 (15%)	\$2 (0%)
Trash or rubbish chute, area or container	5 (5%)	\$0 (0%)
Heating equipment room	5 (5%)	\$5 (1%)
Art gallery, exhibit hall, or library	4 (3%)	\$1 (0%)
Records storage room or vault	3 (3%)	\$34 (7%)
Exterior roof surface	3 (3%)	\$8 (2%)
Unclassified outside area	4 (6%)	\$7 (0%)
Exterior roof surface	3 (4%)	\$2 (0%)
Exterior wall surface	3 (3%)	\$1 (0%)
Garage or vehicle storage area	3 (3%)	\$0 (0%)
Lawn, field, or open area	3 (2%)	\$1 (0%)
Unclassified storage area	2 (2%)	\$0 (0%)
Unclassified area of origin	2 (2%)	\$17 (3%)
Small assembly area with less than 100-person capacity	2 (2%)	\$3 (1%)
Duct for HVAC, cable, exhaust, heating, or air conditioning	2 (2%)	\$1 (0%)
Unclassified equipment or service area	2 (2%)	\$2 (0%)
Large open room without fixed seats	2 (2%)	\$0 (0%)
Other known area of origin	22 (21%)	\$405 (79%)
Total	107 (100%)	\$516 (100%)

Note: These are fires reported to U.S. municipal fire departments and so exclude fires reported only to federal or state agencies or industrial fire brigades. Fires are rounded to the nearest one and property damage is rounded to the nearest thousand dollars. Fires in which the area of origin was unknown or not reported were allocated proportionally among fires with known area of origin. Sums might not equal totals due to rounding errors. Property damage estimates have not been adjusted for inflation.

Source: National estimates based on NFIRS and NFPA survey.

fire was attributed to flammable gasses in a canister of spray foam being ignited by a hot projector nearby. A staff member was present when the fire was ignited, but was unable to contain the fast-spreading flames. Contributing to the rapid fire spread were the number of timber lined walls and voids, original ventilation ducts running both vertically and horizontally throughout the building, and a vertical service void running the entire height of the building which allowed the fire to travel unabated. At the time of the fire, installation of a new fire suppression system was nearing completion, but it had been delayed due to the discovery of asbestos.

Charles Rennie Mackintosh is lauded as Scotland's most influential architect and designer, with the art school building that bears his name considered by many to be his greatest masterpiece.

B.3.2.2 Georgetown Neighborhood Library, DC Pubic Library, Washington, DC — April 30, 2007. The fire broke out around 12:30 p.m. and quickly spread to the roof, and within minutes of receiving the call, firefighters began to arrive. Firefighters were eventually able to bring the fire under control. All patrons and staff were evacuated from the building safely. The building contained a special collection of Georgetown "local history" known as the Peabody Room. The Peabody collection received only smoke and water damage and was quickly removed from the building and flash frozen. About 90 to 95 percent of the collection was able to be saved, including several paintings and rare items. The general circulating collection received significant water and fire damage resulting in a substantial loss. The Georgetown Library was renovated at a cost of about \$26 million.

B.3.2.3 Anna Amalia Library, Weimar, Germany — September 2004. Estimated 60 million euro (\$73 million) loss. A fire in the Anna Amalia Library in Weimar, Germany, destroyed about 10 percent of the library's books and artwork and caused more than 60 million euros of damage. Investigators believe an overloaded electrical circuit caused a smoldering fire that burned for some time in a second floor room of the library before it began to spread. The library was equipped with smoke detection, but there was no automatic fire suppression system installed. Renovation work was under way in the building at the time of the fire.

B.3.2.4 Alexander Blok Library, St. Petersburg, Russia — February 20, 2004. Partial loss. A five-alarm fire broke out in the building on St. Petersburg's famed Nevsky Prospekt that houses the Alexander Blok Library, as well as an art gallery and shops. The fire was extinguished about five hours after it started. The library's collection of literature and musical scores escaped damage from the flames, but the fire service reported that much of the collection was soaked with water. The building was not sprinklered.

B.3.2.5 University of Georgia Main Library — July 23, 2003. Estimated \$10–\$12 million loss. An arson fire broke out in the main library at the University of Georgia at 5:45 p.m., with about 200 people in the building. Although the fire was contained in the second floor, there was smoke damage throughout the building because the fire dampers in the air returns did not shut down the air handling system until heat melted the fire links on dampers. The fire was confined to an area surrounding an office that had been converted to a storage room, which contained computers, books and documents. Although the fire was contained within 20 minutes after firefighters arrived, the second floor of the annex portion of the

main library sustained several hundred square feet of fire damage, and the fire burned through a collection of historical documents of the Internal Revenue Service, the Food and Drug Administration, the Securities and Exchange Commission, and the State of Georgia. At the time of the fire, the only smoke detectors in the library were located at the fire doors of each egress stair. Smoke detectors activated the fire alarm that summoned the fire department; however, the fire was fully developed by the time the fire department arrived. The original building is four stories and the annex is seven stories with an eighth floor mechanical penthouse. The building is steel frame with concrete and masonry construction. The basement of the annex was the only portion of the building protected by an automatic sprinkler system at the time of the fire. Property loss and restoration costs were estimated at \$10 to \$12 million.

B.3.2.6 Bibliotheca Alexandrina, Alexandria, Egypt — March 2, 2003. Partial loss. A fire, apparently caused by a short circuit in the fourth-floor administrative area, sent thick smoke swirling through the building that had opened to international fanfare in October 2002. The fire lasted about 45 minutes and was confined to the administrative area. No books were destroyed, and the library was able to reopen later in the day; however, the fire prompted authorities to evacuate the 11-story building, and 29 people were taken to hospitals for treatment for smoke inhalation. The \$230 million library, which contains about 240,000 books, a planetarium, conference hall, five research institutes, six galleries, and three museums, is located on Alexandria's renovated seaside promenade. The ancient Alexandria library, founded in about 295 B.C. by Ptolemy I Soter, burned in the fourth century.

B.3.2.7 Glasgow University, Scotland, UK — October 25, 2001. Estimated £12 million (\$10.7 million) loss. At 1:30 p.m. a fire broke out on the top floor of the Bower Building, which for 100 years stood out as a proud and distinctive element of the Glasgow University skyline. Around 40 students in the building, which housed an administration center for the Institute of Biomedical and Life Sciences Department, were evacuated by university staff as black smoke billowed from the roof space. Seventy firefighters used aerial jets in an attempt to stop the flames spreading to nearby science buildings on the West End campus. They also removed radioactive material from the top floor of the building. At one point a number of officers were evacuated from inside the building amid fears the weakened structure was in danger of collapsing. Police cordoned off the building as wreckage from the top floor laboratory fell into the second floor. The divisional fire officer said the fire was brought under control at 5 p.m. The cause of the fire is not known, but students reported that firework noises were heard shortly before the blaze broke out at 1:30 p.m.

The blaze destroyed dozens of rare books and manuscripts and records belonging to at least 2000 undergraduate students, as well as equipment worth £3.5 million (\$6.25 million), although the greatest loss was a unique collection of 19th century botany books including first editions of Darwin's work and some original manuscripts valued at more than £2 million (\$3.6 million). The books were housed in the library in a room known as the Marshall Room on the third floor of the building underneath the roof space. Damage to the building was estimated at £7 million (\$12.5 million).

B.3.2.8 Minnesota Library — 2000. Estimated \$2 million loss. At 11:16 p.m. the fire department responded to a fire in a three-story library of masonry construction. The library was part of an educational complex. Arriving firefighters heard alarms but initially did not see smoke, although they did smell plastic. The fire panel showed heavy smoke, and they found smoke coming from a locked room in the basement. Firefighters encountered more doors and heavier smoke and they began to ventilate the basement and first and second floors. They had to remove the windows because the windows did not open. Investigators determined that the fire originated in the area of the electrical fan and cable television electronic equipment in the video control room. Flame damage was confined to the room of origin, and smoke damage was confined to the floor of origin. Property damage was estimated at \$2 million. The property did not have automatic sprinklers.

B.3.2.9 National Archives — February 29, 2000. Partial loss. A fire of suspicious origin destroyed about 40,000 pages of archival material stored at the Washington National Records Center in Suitland, MD, which stores more than 3.7 million cubic feet of records. The building's sprinkler alarms activated at 2:30 p.m. and alerted the GSA Control Center that there was a problem. The first fire company arrived sometime between 2:45 p.m. and 2:50 p.m. A fireman on the scene was overcome with smoke at which point firemen abandoned Stack 15 to open the roof hatches to vent the smoke. This process apparently took approximately one hour to accomplish before the firemen returned to Stack 15 to begin to extinguish the fire. The sprinkler system contained the fire during the period between 2:30 p.m. and 3:50 p.m. at which point the firemen were able to enter the stack.

The bulk of the records kept in the area where sprinklers went off were inactive files of deceased war veterans from the Department of Veterans Affairs, and records from the Bureau of Indian Affairs, the Labor Department's Hour and Wage Division, the U.S. Patent and Trademark office, and District of Columbia government offices. Following the fire, conservators stored wet documents in refrigerated trucks to prevent mold and mildew, and the walls, floors, and boxes in the building were professionally cleaned to remove soot and smoke residue.

B.3.2.10 Bryan College Library Collections, Dayton Tennessee — February 2000. Partial loss. Fire destroyed the top floor of a Bryan College building that contained historical documents from the famed Scopes "Monkey Trial," but few papers tied to the famed case were damaged and no one was hurt. The most significant loss of the college's memorabilia from the trial of John Scopes, a science teacher prosecuted for teaching evolution, was William Jennings Bryan's personal copy of Charles Darwin's *The Origin of Species*. The building was completed in the 1950s and had no sprinkler system.

B.3.2.11 Village Library, Centerburg Ohio — January 28, 2000. Partial loss. At approximately 2 a.m. the local sheriff deputy spotted smoke coming from the building while making his rounds. Approximately one-third of the second story was involved. Investigation revealed that an electrical heat tape on a water line in the upstairs portion of the building that was used maybe once a month malfunctioned, melted, and ignited. Extinguishment was hindered by an electric line very close to the building and subzero temperatures that caused ice to form as quickly as water was sprayed. The volunteer fire department had no large ladder truck that would reach the roof area of the

2-plus story building, and fire fighters had to take down power lines surrounding the library to fight the flames.

The building, a 2-plus story brick building with multiple roof layers, built in 1893, had no fire protection systems. The collection included more than 25,000 videos, CDs, magazines, and historical items. Quick-thinking volunteer firefighters woke the local hardware store owner and got all the plastic sheeting they could find, along with their own tarps, and covered all books shelves before most of the water came down from the second floor. Only 700 books were lost and within six hours of the state fire marshal's release of the building, all materials had been removed. A recovery company freeze-dried some of the books and boxed and stored all materials. The library, which is one of only 17 association libraries in the state of Ohio, was closed for six months following the fire.

B.3.2.12 Central Library, Virginia Beach, Virginia — January 22, 2000. Partial loss. At 10:00 p.m., a small firebomb tossed through a broken window started a fire that damaged the local history and genealogy section of the city's Central Library. A fire department spokesman said the bomb was filled with a petroleum-type substance. Fire investigators noticed that a nearby window, almost floor-to-ceiling in length, had been broken. They said the break was large enough for the bomb to be tossed through, but not for a person to enter. An alarm alerted the fire service at 10:19 p.m., and four minutes later a ladder truck and a second unit arrived at the library. Smoke had filled the library by the time firefighters consulted the control panel to locate the blaze. Fire officials said the blaze had been quickly controlled by the sprinkler system. A computerized card-catalog terminal and two racks of books sustained fire and water damage, fire department and library officials said, and firefighters finished extinguishing the smoldering fire with portable extinguishers.

B.3.2.13 Linköping City Library, Linköping, Sweden — September 20, 1996. Partial loss. This important city library was largely destroyed by a fire that appeared to have been set deliberately at 11:00 p.m. in the immigrants' information office, which was located in the same building. Six hundred people attending a conference escaped safely. Within 20 minutes the building was fully involved. The fire services were sparing in their use of water in order to prevent water from entering the basement storage areas where the manuscript collections were located. Most of these were saved, although about 70,000 books were lost.

B.3.2.14 Virginia Library, Hampton, Virginia — July 1996. Estimated \$4.5 million loss. At about 10:00 p.m., an occupant of a dormitory in an adjacent structure notified the fire department of a fire on the roof of a structure containing a library and a linen exchange. The one-story building, of ordinary construction, covered an area of 2378 m² (25,602 ft²). Walls were block, the floor framing was concrete, the roof framing and deck were wood, and the roof was covered by built-up tar and gravel. The building had two ceilings. The property was closed for the night. Arriving fire fighters found smoke coming from the structure's roof. An investigation revealed that an unknown person had intentionally ignited ordinary combustibles in a rear storage room. Holes in the lower ceiling allowed the fire to spread to the area between the roof and the original ceiling. A brisk wind fanned the fire throughout the building. It is believed that the fire burned for approximately 10 minutes before it was detected. Automatic heat detectors were present in the library and the linen exchange office, but not in the

room where the fire started. They were not activated. No suppression system was present. The structure and contents were destroyed. Two vehicles parked nearby were also damaged by radiant heat. Total direct property damage was estimated at \$4,500,000. No injuries were reported.

B.3.2.15 Carrington City Library, Carrington City, North Dakota — November 5, 1994. Total loss. An arson fire destroyed the building and its contents, valued at more than \$200,000. Only half of that amount was covered by insurance. The library's entire collection of nearly 13,500 books had to be discarded, with the exception of about 300 books that were in circulation at the time of the fire.

B.3.2.16 Norwich Central Library, Norwich, England — August 1, 1994. Partial loss. Fire destroyed more than 350,000 books, with many priceless manuscripts, some dating to the 11th century, suffering water damage from fire fighter hose streams. The fire is believed to have started as a result of faulty wiring in a bookcase. The collections contained more than two million documents, including cathedral records dating back to 1090. The London Daily Telegraph reported, "Norwich refurbished its 31-year-old library earlier this year [1994] but decided not to install a sprinkler system, fearing it would cause too much damage if there was a fire." Even though the library was located adjacent to the city's main fire station, the fire was out of control by the time the fire department arrived.

B.3.2.17 Grand Canyon Community Library, Grand Canyon Village, Arizona — March 18, 1994. Estimated \$1 million loss. A 9:00 a.m. fire destroyed approximately 14,000 books in a building that had been listed on the National Register of Historic Places. Only 500 books that were in circulation at the time of the fire were not destroyed. Cause of the fire was not reported. Loss was estimated at over \$1 million.

B.3.2.18 Dakota County Library Branch, Hastings, Minnesota — June 4, 1993. Estimated \$1.3 million loss. An arson fire involving a juvenile destroyed the entire library collection of 73,500 books and caused \$300,000 damage to the building. Damage to books and library furnishings were estimated at more than \$1 million. A passing motorist reported the fire at 4:30 a.m. The building had no automatic fire detection or suppression systems because it was considered "up to code" since it had been constructed in 1964 before sprinklers were required.

B.3.2.19 Broward County Main Library, Fort Lauderdale, Florida — March 23, 1993. Partial loss. The library's automatic sprinkler system contained a fire in a first-floor trash room at about 9:57 p.m. on a Sunday. Investigators believe a carelessly discarded cigarette caused the fire. Excess trash from a week-end special event in the library contributed to the severity of the fire. Still, only portions of the first floor were damaged, including security and delivery offices and storage rooms. Some library materials in those areas were also damaged.

B.3.2.20 Rio Vista Library, Rio Vista, California — January 16, 1993. Total loss. A fire caused by a radiator heater igniting combustible materials left nearby when staff departed at 5 p.m. destroyed the library's total collection of 32,000 books and the historic building that housed them. Persons attending a meeting in a second floor room discovered the fire at 10:15 p.m. Losses were estimated at \$1.3 million.

B.3.2.21 South Bend Public Library, South Bend, Indiana — October 28, 1992. Partial loss. A fire that started in an elevator shaft during the unoccupied early morning hours spread into a mezzanine area, but damage to the building was minimal. The sprinkler system was credited with containing the fire and preventing it from extending into library collection materials. An alarm to the fire department from the building was delayed because the fire detection systems were still not connected more than two weeks after dedication ceremonies for the renovated and expanded building. The fire department found the fire nearly extinguished by the automatic sprinkler system. Damage was limited to smoke, carpet, elevator and elevator shaft, and glass windows to the main entrance door and roof-top skylights.

B.3.2.22 Calgary Public Library, Thornhill Branch, Calgary, Alberta, Canada — April 1, 1990. Estimated \$500,000 loss. Fire fighters were called to an arson fire in a building that housed the library and a Calgary social and health services office at 4:30 a.m. Initial estimates of \$1 million in losses were subsequently reduced by more than half when it was determined that, of the 60,000 books damaged in the fire, more than 80 percent could be salvaged. These were mostly smoke-damaged books that could be cleaned.

B.3.2.23 Bailey-Howe Library, University of Vermont, Burlington — March 21, 1990. Estimated \$105,965 loss. Staff arriving at 7:30 a.m. smelled an electrical burning odor. An electrical fault had ignited the fabric wrapping on an air supply duct in the air return plenum above the suspended ceiling. By the time the source of the smoke was discovered, the fire had burned itself out. At the time of the fire there was no interconnection between the automatic smoke detection system and the air handling system to shut it down upon detection of smoke. Damage to the library was limited to the effects of the smoke and the removal of parts of the ceiling. Final cost to the institution was \$105,965. The library reopened two days later, and the most affected part of the building was off-limits to students for the balance of that spring semester. An automatic sprinkler system had been retrofitted to the building in 1981, but only below the suspended ceiling.

B.3.2.24 Nellie McClung Public Library, Victoria, British Columbia, Canada — December 4, 1989. Estimated \$1-\$2 million loss. Fire was discovered shortly after midnight by a passing police patrol and at first was suspected to be arson because of the explosive pace of fire development. Arson was subsequently ruled out because no trace of forced entry or use of flammable liquid accelerants was found. The 13-year-old building was gutted and 34,000 books destroyed. It took the fire fighters 45 minutes to control the fire and five hours to fully extinguish it. The fire caused damage in the range of \$1 million to \$2 million to the library and its collections. It was reported that automatic sprinkler protection had only been provided in the boiler room, leaving the remainder of the building unprotected.

B.3.2.25 Library of USSR Academy of Science, Leningrad, Russia — February 14, 1988. Partial loss. A fire that started as a result of an electrical defect in a newspaper collection storage room of this great library burned for 2 hours unnoticed because the detection system failed. Forty brigades then pumped water into the flames for the next 19 hours. The incident was deemed by Soviet journalists to be a national disaster on a parallel with the Chernobyl nuclear catastrophe. Destroyed by fire were 400,000 volumes of rare or unique

works; another 3.6 million books were water soaked. As Pravda reported, “The disaster could well have been prevented.”

B.3.2.26 Los Angeles Central Library, Los Angeles, California

B.3.2.26.1 April 29, 1986. Partial loss. An arsonist set a fire on tier 5 in the multi-tier book stacks at 10:40 a.m. when there were 400 persons in the library. A detection system gave immediate notice of the fire to a security officer, and the fire department was called. The security officer responded to tier 6 as indicated by the smoke detection annunciator panel but found no fire there at that time. The “deck slits” had not been sealed with smoke barriers when the smoke detection system was installed, as they were still needed for book stack ventilation, which allowed smoke to rise and trigger a detector on another tier. As a result, the opportunity was lost for occupant extinguishment while the fire was small. Time available for occupant action was probably very short because, typical of fires in multi-tier book stacks without automatic sprinkler protection, vertical fire spread through the open deck slits would have been very rapid — possibly less than 10 minutes from tier 5 to the top tier in the book stack (tier 8). The fire department response was prompt, but the fire proved one of the most difficult Los Angeles had ever seen, and it was over 7½ hours later that it was declared under control. More than 400,000 items were destroyed, and 700,000 wet books were placed in freezer warehouses to await eventual restoration. Damage to the reinforced concrete building structure and its historic fabric was extensive and significant. The senior fire service officer, Chief Donald Manning, said “If it had been sprinklered we might have had a few hundred books damaged; we might have had a few thousand dollars damage.” (See “*Investigation Report*” in *NFPA Fire Journal*, March/April 1987.)

B.3.2.26.2 September 3, 1986. Estimated \$2 million loss. A second incendiary fire struck the Central Library, causing \$2 million damage to music collections, where papers had been stacked to start the fire. The public had been excluded from the building since the April 1986 fire, and only staff members and security people were there.

B.3.2.26.3 October 11, 1988. Estimated \$500,000 loss. A third fire resulted when hot metal from welding operations on the third floor dropped down a chute into scrap lumber in the basement. Damage was limited to smudging of the elegant murals that had been cleaned after the 1986 fires at a cost of \$500,000. The fire fighters put down the flames in 30 minutes.

B.3.2.27 Saint Joseph State Hospital Library, Saint Joseph, Missouri — July 31, 1982. Partial loss. A fire of incendiary origin in the second-floor library of this three-story medical care facility was controlled with the operation of two automatic sprinklers. The minimal damage was confined to the room of origin.

B.3.2.28 Hollywood Regional Library, Hollywood, California — May 2, 1982. Estimated \$5 million loss. Vandals broke into the library during the night and set it on fire. There were neither sprinklers nor automatic detection equipment. The destruction was almost total, and the loss amounted to more than \$5 million. A large and rare motion picture history collection was destroyed. A new building replacing this library was dedicated in June 1986 with the design incorporating modern protection systems (i.e., automatic suppression and detection).

B.3.2.29 University of Utah, Salt Lake City — December 17, 1981. Estimated \$2600 loss. A fire resulting from an overheated slide projector in the basement of the Eccles Health Sciences Library was extinguished with the operation of two automatic sprinklers. Notification of the public fire department was prompt through the action of smoke detectors. An estimated loss of \$2600 was confined for the most part to visual aid equipment.

B.3.2.30 San Diego Aerospace Museum and Library, San Diego, California — February 22, 1978. Estimated \$16.3 million loss. A fire of incendiary origin destroyed the museum and library. The loss, estimated at \$16.3 million, included artifacts, works of art, photographs, and the Prudden Collection of 10,000 volumes. At the time of the fire, the 62-year-old structure was undergoing reconstruction, which involved replacement of exterior cement plaster. During this operation the underlying plywood used in the construction was exposed, and the fire was set in the plywood. The building had neither sprinklers nor automatic fire detection systems.

B.3.2.31 Ceres Public Library, Ceres, California — August 14, 1977. Estimated \$230,000 loss. The Gondring Library and several adjacent offices were destroyed in a fire that developed when two youths dropped a paper match into a book return slot. The library loss was approximately \$230,000. There were neither sprinklers nor automatic fire detection equipment.

B.3.2.32 University of Toronto Engineering Library, Toronto, Ontario — February 1977. Estimated \$6.25 million loss. A fire of undetermined origin in the Sir Sandford Fleming Building caused severe damage to the Engineering Library collections and to the building. The building loss was estimated at \$5.85 million and the cost of repair or replacement of books at \$700,000. There were no sprinklers in the building. A detection system sent alarms, but, because alarm circuits were being tested during the night, the signals were confused, causing a delayed response.

B.3.2.33 Temple University Law Library, Philadelphia, Pennsylvania — July 1972. Estimated \$5 million loss. A fire originating in an office area gutted the Charles Klein Law Library and caused extensive damage to the collections. There were neither sprinklers nor automatic detection equipment, and a passerby reported the fire at 1:45 p.m. The fire department attacked the fire and subdued it in 90 minutes, pouring water into the building at the rate of 41,635 L/min (11,000 gpm) at one point. Salvage of wet books held the damage to collections at \$1.72 million, while the total loss was estimated at \$5 million. (See “*Investigation Report*” by A. Elwood Willey in *NFPA Fire Journal*, November 1972.)

B.3.2.34 Jewish Theological Seminary Library, New York, New York — April 1966. Estimated \$8.18 million loss. Employees fought an incendiary fire on the 10th floor of a 12-story tower for 20 minutes before calling the fire department. There were no automatic systems for detection or suppression of fire. The loss was estimated at \$8.18 million and included irreplaceable books and manuscripts.

B.3.2.35 New York University Library, New York, New York — January 1965. Estimated \$7000 loss. A fire in a library book stack was extinguished with the operation of one automatic sprinkler. Total loss was approximately \$7000.

B.3.2.36 Michigan State Library and Office Building, Lansing, Michigan — February 8–13, 1951. Estimated \$2.85 million loss. An incendiary fire burned for five days, resulting in a loss of \$2.85 million and two floors of the building that could not be salvaged.

B.3.2.37 New York University Library, New York, New York — February 1951. Estimated \$1000 loss. A fire in the book stacks of a 10-story, completely sprinklered, fire-resistive building was extinguished with the operation of one sprinkler. Total loss was approximately \$1000.

B.3.2.38 University of Michigan Department of Government Library, Ann Arbor, Michigan — June 6, 1950. A daytime fire set by a faculty member resulted in a \$637,000 loss.

B.4 Places of Worship. There was an annual average of 1,776 religious or funeral property fires reported to municipal fire departments in the period 2007–2011 [see Table B.4(a)]. Most of these fires (67 percent) occurred during normal operating hours (9 a.m.–9 p.m.) but resulted in only 36 percent of direct property damage costs, while fires that occurred between midnight and 6 a.m. resulted in 43 percent of direct property damage costs [see Table B.4(b)]. The majority (95 percent) of direct property damage costs can be attributed to four causes of fire: intentional, heating equipment, electrical distribution equipment, and lightning [see Table B.4(c)]. While most fires (30 percent) originated in kitchens, cooking, or heating equipment areas, the direct property damage costs for these fires were low (8 percent). The most costly fires originated in attics, roof assemblies, concealed spaces, or large assembly areas [see Table B.4(d)].

B.4.1 Why Fires in Places of Worship Spread. The ways in which places of worship are used and their design and construction create many opportunities for fire spread. Delayed discovery and reporting is one of the primary reasons fires in places of worship generally result in significant damage or a total loss of the facilities. The principal factors affecting the spread of fires in places of worship are undivided open areas, concealed spaces, and combustible construction, interior finishes, and furnishings. Automatic sprinklers combined with fire safe building design and fire-resistive construction, finishes, and furnishings are the best way to ensure fire safety in places of worship.

Table B.4(a) Reported Structure Fires in Religious or Funeral Properties, by Year, 2007–2011

Year	Fires
2007	1,890
2008	1,810
2009	1,800
2010	1,720
2011	1,660

Note: These are fires reported to U.S. municipal fire departments and so exclude fires reported only to federal or state agencies or industrial fire brigades. Fires are rounded to the nearest ten.

Source: National estimates based on NFIRS and NFPA survey reported in NFPA's 2013 report, *U.S. Structure Fires in Religious and Funeral Properties*, by Richard Campbell. The 2012 estimate was based on a separate query from NFIRS and NFPA's annual fire department experience survey.

Table B.4(b) Structure Fires in Religious and Funeral Properties by Alarm Time, 2007–2011 Annual Averages

Alarm Time	Fires	Direct Property Damage (in Millions)
midnight–3 a.m.	120 (7%)	\$23 (21%)
3 a.m.–6 a.m.	110 (6%)	\$25 (23%)
6 a.m.–9 a.m.	180 (10%)	\$9 (8%)
9 a.m.–noon	330 (19%)	\$7 (6%)
noon–3 p.m.	280 (16%)	\$9 (8%)
3 a.m.–6 p.m.	300 (17%)	\$11 (10%)
6 a.m.–9 p.m.	290 (16%)	\$13 (12%)
9 p.m.–midnight	150 (8%)	\$14 (13%)
Total	1,780 (100%)	\$111 (100%)

Note: These are fires reported to U.S. municipal fire departments and so exclude fires reported only to federal or state agencies or industrial fire brigades. Fires are rounded to the nearest ten and property damage is rounded to the nearest million dollars. Sums might not equal totals due to rounding errors. Property damage estimates have not been adjusted for inflation.

Source: National estimates based on NFIRS and NFPA survey reported in NFPA's 2013 report, *U.S. Structure Fires in Religious and Funeral Properties*, by Richard Campbell.

Table B.4(c) Leading Major Causes of Reported Structure Fires in Religious or Funeral Properties, 2007–2011 Annual Averages

Leading Major Cause	Fires	Direct Property Damage (in Millions)
Cooking equipment	540 (30%)	\$5 (4%)
Heating equipment	290 (16%)	\$27 (24%)
Intentional	280 (16%)	\$28 (25%)
Electrical distribution or lighting equipment	190 (10%)	\$28 (26%)
Lightning	70 (4%)	\$22 (20%)
Candle	70 (4%)	\$5 (5%)
Exposure fire	50 (3%)	\$4 (3%)
Smoking materials	50 (3%)	\$2 (2%)
Playing with heat source	50 (2%)	\$1 (1%)
Electronic, office, or entertainment equipment	30 (2%)	\$3 (3%)

Note: Leading causes are pulled from several NFIRS data elements and include proportional shares of fires with unknown data. Double counting is possible. These are fires reported to U.S. municipal fire departments and so exclude fires reported only to federal or state agencies or industrial fire brigades. Fires are rounded to the nearest ten and property damage is rounded to the nearest million dollars. Property damage estimates have not been adjusted for inflation.

Source: National estimates based on NFIRS and NFPA survey reported in NFPA's 2013 report, *U.S. Structure Fires in Religious and Funeral Properties*, by Richard Campbell.

Table B.4(d) Reported Structure Fires in Religious or Funeral Properties, by Area of Origin, 2007–2011 Annual Averages

Area of Origin	Fires	Direct Property Damage (in Millions)
Kitchen or cooking area	410 (23%)	\$4 (3%)
Heating equipment room	120 (7%)	\$5 (5%)
Attic or ceiling/roof assembly or concealed space	70 (4%)	\$16 (15%)
Small assembly area with less than 100-person capacity	70 (4%)	\$7 (6%)
Unclassified outside area	70 (4%)	\$1 (1%)
Exterior roof surface	60 (3%)	\$6 (5%)
Unclassified area	60 (3%)	\$1 (1%)
Exterior wall surface	50 (3%)	\$2 (2%)
Lavatory, bathroom, locker room, or check room	50 (3%)	\$1 (0%)
Large assembly area with fixed seats	50 (3%)	\$12 (11%)
Office	40 (2%)	\$5 (4%)
Unclassified function area	40 (2%)	\$4 (3%)
Duct for HVAC, cable, exhaust, heating, or air conditioning	40 (2%)	\$0 (0%)
Large open room without fixed seats	40 (2%)	\$3 (3%)
Lobby or entrance way	30 (2%)	\$4 (3%)
Wall assembly or concealed space	30 (2%)	\$3 (3%)
Trash or rubbish chute, area or container	30 (2%)	\$0 (0%)
Unclassified storage area	30 (2%)	\$0 (0%)
Common room, lounge, or den	30 (2%)	\$0 (0%)
Other known area of origin	460 (26%)	\$33 (30%)
Total	1,780 (100%)	\$111 (100%)

Note: These are fires reported to U.S. municipal fire departments and so exclude fires reported only to federal or state agencies or industrial fire brigades. Fires are rounded to the nearest ten and property damage is rounded to the nearest million dollars. Fires in which the area of origin was unknown or not reported were allocated proportionally among fires with known area of origin. Sums might not equal totals due to rounding errors. Property damage estimates have not been adjusted for inflation.

Source: National estimates based on NFIRS and NFPA survey reported in NFPA's 2013 report, *Structure Fires in Religious and Funeral Properties*, by Richard Campbell.

B.4.2 Illustrative Fires in Places of Worship. The descriptions of fires in B.4.2.1 through B.4.2.37 illustrate some of the more common sources of ignition, factors contributing to fire spread, and the enormity of the losses suffered. It is important to note that these destructive fires are not limited to a particular geographical area or population, but occur across the country — in rural areas and big cities.

Note: The descriptions in B.4.2.1 through B.4.2.37 are from newspaper articles and other publicly available but unofficial sources; therefore, attributions of cause, estimates of damage, and other facts presented in these descriptions might be open to question. Nevertheless, the descriptions illustrate trends and contain information that can be of value in evaluating the overall fire problem in places of worship.

B.4.2.1 Lutheran Church of Hope, Anchorage, Alaska — January 30, 2016. Limited loss. Vandals broke into the church through a back window, tipped over the baptismal font in the sanctuary, ripped through some mail, then made their way to the kitchen, where they ignited the stovetop and piled papers on top of the burners. The fire activated the sprinkler system, dousing the fire before it could spread to other parts of the

church, with only one head operating. Loss was limited to fire, smoke, and heat damage within the kitchen.

B.4.2.2 Christ the King Catholic Church, Chicago, Illinois — October 7, 2015. Spontaneous combustion of rags that had been used by volunteers to stain the floors of the choir pews in the sanctuary, as part of a major renovation project, was cited as the cause of a fire that engulfed this church, which had been designated as a Chicago Historic Landmark in 2006. The fire traveled from the front to the back of the church, from the second floor all the way up the roof section and then ran the whole length of the building. Flames could be seen shooting through the roof and steeple. A large portion of the wood truss roof collapsed. The multimillion dollar renovation project was planned to restore the building, which had been damaged by a previous fire in the 1970s.

B.4.2.3 Saint-Donatien Basilica, Nantes, France — June 14, 2015. An intense fire engulfed the historic neo-Gothic Basilica dating to the 1890s. The fire broke out after morning mass, with worshipers evacuating the building. Much of the roof was destroyed, although more than 40 firefighters worked to contain the fire. Welders conducting waterproofing work on the roof were reported to have accidentally started the fire and

attempted to extinguish it, without success. The workers were able to escape the fire; people from the area assisted in removing artifacts and historic artwork from inside the building.

B.4.2.4 New Shiloh Christian Center, Melbourne, Florida — February 16, 2015. Estimated \$5000 loss. Burglars broke into an area of the building that was slated for a trade school, kicked in doors, scrawled graffiti, and set fire to some furniture and chairs in an attached storage unit, and a locked door leading into the maintenance area where the electrical room and a large diesel tank were located. Sprinklers operated, keeping the fire from spreading to the electrical room. The main sanctuary, housed in the same 11,600 m² (125,000 ft²) building, was not affected by smoke or fire. This was the second time in less than two weeks that vandals attacked the building.

B.4.2.5 Second Baptist Church, Houston, Texas — January 1, 2015. Negligible loss. A single sprinkler extinguished a fire that broke out in a television in the lobby of the church. The building was unoccupied at the time. The fire department ventilated the building with multiple fans and began removal of the water in the lobby. Loss was reportedly limited to a small amount of water damage.

B.4.2.6 St. Mel's Cathedral, Longford, Ireland — December 25, 2009. Estimated €30 million (\$43.2 million) loss. Early Christmas-morning fire broke out at the back of this landmark cathedral, dating back to 1856, and quickly spread to engulf the entire building. The fire burned for several hours, with flames at one point reportedly jumping 18 m (60 ft) into the air. Fire fighters' attempts to control the fire were hampered by water shortages due to freezing temperatures affecting the municipal water supply during the especially harsh weather. Only the exterior walls of the cathedral survived, along with the campanile and portico — most of the contents of the building were lost. The fire damaged St. Mel's Crosier, a relic dating back over a thousand years; the entire collection of vestments, penal crosses, altar vessels of pewter and silver was lost, as were a number of Harry Clarke's Celtic Revival stained glass windows, although a few were saved and restored. The cause of the loss was listed as an overextension of the heating system.

B.4.2.7 Trinity Cathedral, St. Petersburg, Russia — August 25, 2006. Estimated 1.6 million ruble (\$60,000) loss. An early evening fire apparently started on scaffolding on the outside of the church, which was undergoing restoration, collapsing the blue central rooftop dome and destroying one of four smaller cupolas surrounding it. Apparently a fire broke out on the scaffolding after someone threw down a cigarette butt. The fire burned through the scaffolding and spread to the central dome. The fire was contained about four hours after it started. Damage to the cathedral, which is included in UNESCO's World Heritage List, was estimated at over 1.6 million rubles.

B.4.2.8 St. Catherine's Church, Gdansk, Poland — May 23, 2006. Partial loss. A fire in this historic church, which has architectural elements dating back to the 13th century, caused the roof to collapse. Workmen had been repairing the church roof earlier in the day. The church contained Renaissance and Baroque paintings, a museum of church clocks, and a unique carillon — a musical instrument containing several bells. St. Catherine's Church had been largely destroyed by fire in 1905 but had since been reconstructed.

B.4.2.9 University City Church, Charlotte, North Carolina — March 20, 2006. Estimated \$500,000 loss. An arsonist caused about \$500,000 in damage to the church after setting more

than 20 small fires inside. Investigators described the fires as amateurish. One of the fires was set by piling napkins and other paper on top of a stove in the kitchen and turning on a burner. The fires set off sprinklers inside the church, which triggered an alarm to the fire department. Fire fighters put the fire out quickly, and no one was injured.

B.4.2.10 St. Jude's Cathedral, Iqaluit, Nunavut – November 13, 2005. Partial loss. A fire of suspicious origin caused extensive damage to this igloo-shaped church, an Arctic landmark. The fire also destroyed art works and other artifacts inside the church, which is shaped like an Inuit snow house with a spire atop the dome.

B.4.2.11 Laurel Grove Baptist Church, Franconia, Virginia — December, 2004. Total loss. An electrical malfunction in the attic of the church ignited a small fire that quickly spread through the 120-year-old wooden structure, destroying the building. The fire was first reported to the county's fire and rescue department at about 4:10 a.m. by a motorist driving by who noticed flames shooting out from the church's roof. About 50 fire and rescue personnel brought the fire under control in about 30 minutes. Two fire fighters were slightly injured after slipping on ice created by their hoses.

B.4.2.12 Bethel Church, Elizabeth, West Virginia — December, 2004. Total loss. An arson fire that appeared to have been a cover for a theft destroyed this historic Wirt County church. There was evidence of larceny and breaking and entering prior to the fire, which was reported at around 9:50 p.m. First-responding fire department personnel found the church fully engulfed in fire. Thieves apparently removed a propane heater and all of the church's 1500 mm (5 ft) wooden pews, which were original pieces of the 1898 church, before starting the fire. The pews, built of solid wood and nailed into the floor, were heavy enough to need at least two people to move them. The church was also the victim of arson in the late 1980s. The church, which was not insured, was a complete loss.

B.4.2.13 Harbin New Synagogue, Beijing, China — November, 2004. Partial loss. A fire, caused by construction workers, damaged a historic synagogue in the north China city of Harbin. The building, dating from the 1920s when the city boasted a Jewish community of more than 20,000, was undergoing restoration work before reopening as a museum of Jewish history and culture. The fire destroyed nearly half of the newly restored dome. The building was built in 1921, and it was the largest synagogue in the Far East, with a floor area of 1233 m² (13,272 ft²) and room for 800 worshippers.

B.4.2.14 Ebenezer Baptist Church, Pittsburgh, Pennsylvania — March, 2004. Total loss. A fire, believed to have been electrical in nature, started in the basement of the building and killed two fire fighters and injured 29 others when the church collapsed as they tried to put out the fire. According to reports, the fire jumped up the walls and spread rapidly. Fire fighters entered the building about an hour after the fire started to douse hot spots when the fire flashed over, engulfing the sanctuary, and the roof and steeple collapsed.

B.4.2.15 Praise International Church, Vancouver, British Columbia — January, 2004. Total loss. A four-alarm fire of suspicious origin destroyed Vancouver's third-oldest church, a stunningly beautiful heritage-listed building in Mount Pleasant. Neighbors called in the alarm shortly after 5 a.m. after seeing smoke coming out a window. By the time fire fighters arrived, the fire had broken through the roof and the building was fully

involved. At one point flames were roaring 30 m (100 ft) into the air and more than 35 men and 12 trucks were called in. Nothing was saved from the church, which was totally destroyed. Investigators said the fire appeared to have started in the basement sometime before 5 a.m. The Tudor revival style building built in 1909 featured a high hammer beam and truss ceiling and was the only Tudor revival designed church in the city.

B.4.2.16 Exeter Presbyterian Church, Exeter, New Hampshire — November, 2003. Total loss. A four-alarm fire, believed to have been caused by a furnace explosion, destroyed a 158-year-old wood-frame church in downtown Exeter. The fire was already well established when fire fighters arrived at 7:15 a.m. Just after 9:30 a.m., flames broke through the roof of the church, and about 15 minutes later pieces of the roof started to collapse. Fire fighters initially used water from the town of Exeter's hydrant system but later hooked up hose lines to pipe water from the Exeter River as the town's system was strained.

B.4.2.17 St. John's Lutheran Church, Sycamore, Illinois — February 9, 2003. Total loss. A fire of undetermined origin caused a backdraft that blew the church apart in what has been named the largest backdraft ever documented in the U.S. The backdraft blew the roof off the church and injured two fire fighters, who were responding to a rekindle from a fire in the church the day before. The only warning before the blast was a sucking sound. The fire went to a fourth alarm, with 63 fire-fighters from 11 departments responding. After the fire the church's walls were left standing but the structure was unsalvageable. The church, built in 1937 and measuring 46 m × 49 m (150 ft × 160 ft), was made of stone, plaster, terra cotta tile, heavy timber, and stained glass windows covered with Lexan. The backdraft occurred in the sanctuary, which was located below the main church area and measured 24 m × 46 m (80 ft × 150 ft). Reports indicate that the church had voids, including a crawl space and cold air returns, where heat built up, contributing to the backdraft.

B.4.2.18 Our Lady of the Rosary Church, Pirenópolis, Brazil — September, 2002. Total loss. An early morning fire of unknown origin destroyed a historic Brazilian church, consuming gold and artwork imported from Portugal in colonial times. Built by slaves in 1728, the church was decorated with imported treasures, as Pirenópolis developed into a rich regional center for silver mining.

B.4.2.19 St. Michael Catholic Church, Wheaton, Illinois — March, 2002. Total loss (\$4.9 million). An arson fire in the church, which did not have smoke detectors, fire alarms, or sprinklers, burned it to the ground. By the time fire fighters arrived about 2 a.m. the fire was out of control. The fire occurred on 3/18/02, and it was set by a young adult member of the church who entered the building late at night or in the early morning on his way home from being out with friends. The fire destroyed the building, which consisted primarily of the sanctuary, and damaged the rectory next door. The replacement church building was dedicated in 2006.

B.4.2.20 Salem United Methodist Church, Allentown, Pennsylvania — August 2001. Partial loss. A fire at about 12:15 p.m., which started as three workers soldered copper on the roof, heavily damaged this 100-year-old wood frame church. The workers noticed smoke while working outside, then used a ladder to get a closer look from inside the attic, before they asked a church employee to call the fire department. The delay

in reporting the fire allowed it to spread. The church was most badly damaged in its upper sections.

B.4.2.21 First Presbyterian Church, Lexington, Virginia — August, 2000. Partial loss. A hot iron used to strip paint ignited a fire that destroyed one sanctuary of the church. The hot iron, used to soften paint before it's scraped, likely ignited material in the roof area of the wood-frame structure. Completed in 1845, Lexington Presbyterian was designed in the Greek Revival style by renowned architect Thomas U. Walter. Confederate Gen. Thomas J. "Stonewall" Jackson worshipped at the church in the years leading up to the Civil War. The sanctuary had undergone some renovation since it was built. The dry, 155-year-old wood posed a greater fire hazard than newer material. The contractor chosen for the work gave members a demonstration of the hot-iron technique and they approved. A senior architectural historian with the Virginia Department of Historic Resources advises against using heat to strip paint on old wood fixtures that are hollow or that can't be seen from behind, like the cornices being stripped at Lexington Presbyterian, where rats or birds sometimes build nests in unseen areas that can catch fire without workers knowing it.

B.4.2.22 Immaculate Heart of Mary Catholic Church, Phoenix, Arizona — April, 2000. Estimated \$1.5 million loss. A fire, of unknown origin, that caused an estimated \$1.5 million damage to the church started about 3:15 a.m. along a wall near a candlelit shrine to the Virgin of Guadalupe and spread under the floor and to a choir loft, destroying the church's organ. Officials said fire fighters' efforts were hampered by falling chunks of plaster, some weighing 45 kg (100 lb).

B.4.2.23 St. Luke's, Belfast, Pennsylvania — February 29, 2000. Estimated \$1.2 million loss. A spark flying from a saw being used to cut metal siding started a fire within the hollow vestibule wall of the church and, according to the fire investigator, the tower belfry then acted like the chimney of a furnace as fire raced rapidly to the top of the steeple. The wall was not insulated and no modern fire-stops or sprinklers had been installed, so there was nothing to slow the fire's spread. The old church's thick stone side walls and foundation remained intact, but the fire destroyed the sanctuary roof and charred the interior walls, and a portion of the tower collapsed. What the two-hour blaze didn't damage, smoke or water did. No one was injured. The damage was estimated at \$1.2 million.

B.4.2.24 St. Mary Magdalene Church, Los Angeles, California — July 2 & 3, 1999. Estimated \$200,000 loss. Two deliberately set fires hours apart caused approximately \$200,000 damage to this West Los Angeles church. Firefighters managed to extinguish the fires — one set late Friday and the other early Saturday — before they engulfed the entire facility. The church also suffered an arson fire in 1988 and was reportedly the target of repeated vandalism. Both fires broke out in a utility shed attached to the church. The first fire, reported at 10:41 p.m. Friday, was extinguished with little damage after a church alarm system alerted the fire department, but the second fire, shortly after 1 a.m. Saturday, did extensive damage to a chapel adjoining the church, the roof, and the church electrical system. Church officials and parishioners wondered about possible connections to other nearby church arson fires, including a fire in June 1999 that caused an estimated \$1.2 million in damage to St. Thomas the Apostle Roman Catholic Church, four miles to the east. In the last four years, suspicious fires damaged at least two other nearby churches: Our

Lady of Lebanon-St. Peter Cathedral Maronite Church and St. Mark Coptic Orthodox Church.

B.4.2.25 Kansas Church — 1999. Estimated \$2.5 million loss. Workers were using a circular saw with a metal cutting blade to cut a metal rod that operated several windows on a second-floor balcony in a church under renovation, when showering sparks ignited a fire. A worker saw the sparks fall onto several wooden structural members exposed at the roofline. The wood ignited easily because it suffered from dry rot and termite infestation, and the fire spread under the roof as workers tried to find water to extinguish it. Fire fighters, responding to a 911 call from the construction crew at 9:24 a.m., found flames and smoke coming from the corner of the church roof. Workers tried to extinguish the blaze, but the delay in notifying the fire department and the lack of a standby fire extinguisher allowed the fire to spread. The two-story church was of wood-frame construction, with stone walls and a slate roof. It did not have sprinklers or fire detection equipment and was open at the time of the fire. A fire department official observed that, if workers had had access to an extinguisher, it might have been possible to save the building. This type of work qualifies as hot work per NFPA 51B. If NFPA 51B had been followed, a fire watch with an extinguisher would have been established after a hot work permit was issued. Estimated structural loss was reported at \$2 million, with contents loss at \$500,000. There were no injuries.

B.4.2.26 Barrington United Methodist Church, Barrington, IL — October 28, 1998. Total loss (\$4 million). A maintenance worker called 911 at 12:06 p.m. to report a fire in this two-story church that was undergoing exterior renovations. The church, originally built in 1880, had wood frame, balloon construction. The walls, roof framing, and roof deck were wood, and the floors were wood joist. The roof was covered with asphalt shingles. The worker smelled smoke in the chapel area and found fire inside the wall. He tried to put out the fire with an extinguisher but was forced back by smoke. A smoke alarm also sounded, but activation was delayed because of the fire location. A partial sprinkler system in the basement was not a factor in the fire. When fire fighters arrived, they found heavy black smoke coming from the roof and bell tower. Upon entering the building, they found heavy fire overhead and were ordered out of the building.

Workers using a heat gun to strip paint from windows stopped working at about 11:45 a.m., but left the heat gun plugged in and lying on the scaffolding. Heat from the gun ignited wood and/or dust on the scaffolding. The fire quickly traveled through the balloon construction to the attic and through the common space. Damage to the structure was estimated at \$2 million, and loss to the contents was also estimated at \$2 million. Both represented total losses. One civilian and one fire fighter were injured in this fire.

B.4.2.27 Kharkiv Synagogue, Kiev, Ukraine — September, 1998. Partial loss. A fire of suspicious origin damaged one of Ukraine's largest synagogues. The fire in the sanctuary of the synagogue began at 2 a.m. and raged for several hours before fire fighters put it out. The sanctuary was being reconstructed and had no electric wires or gas pipes at the time. Fire spread to the ceiling of the sanctuary, which is as high as a five-story building, but the Torah scrolls were saved. The synagogue was built around 1910 but shortly afterward was converted into a sports stadium by the Soviet government.

B.4.2.28 Central Synagogue, New York, New York — August, 1998. Partial loss. New York City fire fighters spent nearly three hours bringing a fire under control in a landmark Manhattan synagogue. A fire department spokesman says the blaze broke out in the roof of the 126-year-old structure on Lexington Avenue and 55th Street just after 5 p.m. and quickly went to five alarms, with 45 trucks and 250 fire fighters responding. Fire crews poured water on the building from the outside and finally controlled the fire just before 8 p.m. Apparently a small fire started while some work was being done on the building's air conditioning system, and workers believed they had put it out.

B.4.2.29 Pennsylvania Church — 1998. Estimated \$6 million loss. This 2½-story church was constructed of heavy timber and was closed for the night when the fire occurred. The church had no automatic suppression system, and its complete-coverage automatic detection system, of unreported type, failed to activate. However, at 4:52 a.m. a burglar alarm system activated and summoned police, who spotted the fire when they responded. The blaze started in a ceiling/floor assembly over the janitor's room in the basement when an unidentified electrical source ignited wood framing material. The fire spread to the sanctuary. Two fire fighters were injured. A contributing factor to the rapid growth of the fire was that as the ceiling over the janitor's room collapsed, the fire spread through voids in the construction.

B.4.2.30 Wisconsin Church — 1998. Estimated \$1.1 million loss. A church worker called 911 at 9:19 p.m. to report a fire in this two-story, wood-frame church. The structure measured 61 m × 15 m (200 ft × 50 ft), the walls, floor framing, roof framing, and roof deck were wood, and the roof was covered with asphalt shingles. Several volunteers had been attempting to eliminate bees and/or hornets from under the eaves. One individual sprayed ether into about 12 joist pockets. In one pocket, a cigarette lighter was used to create a blowtorch effect with the ether can, with the intention of burning out the insects. This created a small fireball, which workers attempted to pat out with their hands. Believing the fire was out, they continued to spray other joists. The volunteers noticed smoke coming from the roof peak 15 to 20 minutes later. They entered the church, tore down a piece of suspended ceiling, and found fire in the concealed space. They tried to put the fire out with several extinguishers. When these efforts were unsuccessful, the fire department was called.

The extensive use of ether caused the fire to spread quickly and far. Before a significant interior attack could be launched, fire fighters had to ventilate the building of ether vapors. There was about 400 mm (16 in.) of space between the plywood roof deck and the bottom of the joist. About 355 mm (14 in.) of insulation was in place, leaving a 50 mm to 76 mm (2 in. to 3 in.) air space above the insulation and below the plywood. This space acted like a chimney to draw the fire and fumes toward the peak of this 11 m (36 ft) tall structure. Fire fighters opened a small area of the roof in an attempt to ventilate the structure and reach the fire, but the fire's rapid acceleration forced them off the roof before completing the task.

Fire fighters used large exterior streams from ladder trucks and conducted difficult interior operations in an attempt to control the fire. The fire was shielded from the hose streams by the roof until the roof burned off. A large interior balcony also shielded the fire and made it difficult to get water into the ceiling area. Direct property damage to the \$1.5 million structure was estimated at \$1 million. Damage to the \$250,000 in contents was estimated at \$135,000. No injuries were reported. Smoke alarms were present in the interior of the structure, but they were not in the roof joist area and did not operate.

B.4.2.31 Texas Church — 1998. Estimated \$300,000 loss. At about 4:30 a.m., a motion sensor burglar alarm in this 30 m × 30 m (100 ft × 100 ft), single-story church sounded at an alarm company and was relayed to the police station. The police who arrived at the scene notified the fire department of a fire at the site. The structure had brick veneer, concrete floors, and a metal roof deck with dropped ceiling. The roof was covered with tar and gravel. The church was closed for the night. No fire protection systems were present.

Investigators learned that four males, including one juvenile, broke a glass door panel with a hammer and entered the church. They squirted lighter fluid on the carpet in the hallway leading to the fellowship hall and lit it. This fire was not intense enough to satisfy them, so they returned, poured gasoline inside the building, and threw Molotov cocktails inside. Direct property damage to the structure, valued at \$1.5 million, was estimated at \$165,000. Damage to the \$500,000 in contents was estimated at \$135,000. No injuries were reported.

All four suspects pled guilty to charges of arson in a place of worship. Two were sentenced to federal prison, one to a state prison, and the juvenile went to a juvenile facility. Prior to setting this fire, the perpetrators had spent the night drinking, using drugs, and vandalizing cars and homes.

B.4.2.32 Michigan Church — 1997. Total loss. A passerby called 911 at 8:25 p.m. to report a fire in this one-story church, which measured 13 m × 19 m (42 ft × 62 ft) with an additional entry section measuring 3.3 m × 6 m (11 ft × 20 ft.) It also had a finished basement. Exterior walls were brick; interior walls were wood and plaster; the floor, roof framing, and roof deck were wood; and the roof was shingled. No fire protection systems were present. Arriving fire fighters found smoke showing on all sides. An interior attack was begun, but due to heavy fire conditions, all personnel were evacuated and firefighting went to a defensive mode.

The fire originated in the floor joists under the pulpit, between the finished floor of the chapel and the finished ceiling of the basement. The only heat source in that area was electrical wiring, and it appeared that the wiring overheated and ignited floor joints and subflooring, where the fire burned for quite a while. The fire spread into the walls, traveled horizontally across the attic, and vented out of the roof. When the fire entered the chapel, combustible materials, including seating and wood walls, fed it. When the roof collapsed the entire first floor was destroyed, and the basement suffered water and smoke damage. Direct property damage was estimated at \$200,000, equal to the total value. No injuries were reported.

B.4.2.33 Kentucky Church — 1997. Estimated \$700,000 loss. At 1:54 a.m. a passerby called 911 to report a fire at this two-story church of unprotected ordinary construction. The church had brick veneer on the walls, the floor framing was concrete with tile, the roof framing and deck were wood, and asphalt shingles covered the roof. The structure had a ground floor area of 232 m² (2,500 ft²). No fire protection systems were present, and the church was closed for the night. The fire started in a confessional after the thermostat turned on the heater. The heat spread to cardboard boxes containing wine. The cardboard ignited, and flames spread to the wood veneer, curtains, and other items in the confessional. The fire spread upward and outward to other interior finishes and then spread throughout the church. Heavy winds fanned the fire after it vented through the roof. The fire caused an estimated \$700,000 in direct property damage. No injuries were reported.

B.4.2.34 Oklahoma Church — 1996. Total loss. At 4:01 a.m. a passerby called 911 to report a fire in this one-story frame structure with brick veneer. The structure was 46 m × 15 m (150 ft × 50 ft) and was closed for the night. Arriving fire fighters found heavy smoke conditions and fire showing. The west wing was fully involved, and the fire had vented through the south side of the gable roof. The roof of the west side collapsed 20 to 30 minutes later. The fire spread to the east section of the building and that portion of the roof collapsed onto the floor area. The structure, valued at \$225,000, and the contents, valued at \$125,000, were totally destroyed. No injuries were reported.

An investigation revealed that a window had been broken out, and a glass container filled with gasoline had been tossed inside the dining room area. The arsonist used a match to light the gasoline. Two days later, a 35-year-old white male was arrested for arson. The suspect had been arrested for arson twice as a teenager in another state. He was judged incompetent to stand trial and transferred to a mental hospital. Given the perpetrator's condition, law enforcement officials felt the crime was not racially motivated, although the church had a predominantly African American congregation.

B.4.2.35 Minnesota Church — 1996. Total loss. A passerby notified the fire department of a fire at this one-story, wood-frame, balloon-construction church. The structure, built in 1961, was 31 m × 18 m (102 ft × 60 ft wide). The church had a full basement under it. The school/office area was built on a slab and footings. There were no detection or suppression systems. The church was closed up about an hour before the fire was reported. A farmer several miles away saw smoke and flames coming from the church and used his cell phone to notify the fire department. When the fire department arrived, they found heavy fire and smoke coming from the front school addition of the church. As the fire progressed, the roof of the main church collapsed, the first floor collapsed into the basement, and the roof over the fellowship hall partially collapsed. The fire department fought the fire all night. The structure and its contents, valued at \$850,000, were totally destroyed. No injuries were reported.

An investigation revealed that the fire had started in a closet under the balcony when an electrical outlet and associated wiring shorted out or faulted and ignited the adjacent combustible material. The fire smoldered in the wall cavity for a long period of time before spreading to the exterior and then traveling up the wall to the roof.

B.4.2.36 Arizona Church — 1996. Estimated \$1.8 million loss. At 5:19 a.m. a neighbor called the fire department to report smoke and flames coming from the church. The structure was 45 m × 19 m (148 ft × 62 ft), and approximately 11 m (35 ft) at the roof peak. It was brick masonry construction, with brick masonry walls, concrete slab floor, metal truss roof framing, wood-plank roof deck, and built-up rolled roof covering. The structure was closed at the time. Investigators found multiple points of origin, including artificial flowers in the hallway outside the conference room and hymnals scattered in pew areas in the sanctuary. No sign of forcible entry was found, and it appeared that the front middle doors were not secured at the time of the fire. Because of the numerous activities in the building, investigators believed it likely that a door or window could be easily overlooked when locking up. The wood pews, with upholstered and foam-cushioned seats, and books facilitated rapid fire growth and flame spread. The large unpartitioned sanctuary and the stained glass windows allowed the fire to burn and grow for a significant period of time before the upper windows failed and flames became visible to the outside.

The incendiary fire caused an estimated \$1.2 million in direct property damage to the \$6 million structure and \$600,000 in damage to the contents, which were valued at \$1 million. No injuries were reported. No automatic detection or suppression systems were present in the structure. HVAC system fire dampers operated and probably slowed the spread of fire through the attic space. Draft stops in the attic space above the ceiling ran wall to wall and roof to ceiling and also helped slow the fire.

B.4.2.37 Wisconsin Church — 1996. Total loss. At 3:10 a.m. a passerby notified the fire department of a possible fire at this brick and heavy timber structure. The 3½-story building was 24 m × 30 m (80 ft × 100 ft). Walls were made of brick and tile, the floor framing was heavy timber, the roof framing was wood and steel, the roof deck was wood, and the roof covering was asphalt. No fire protection systems were present, and the facility was closed for the night. Arriving fire fighters found the fire in the basement women's room. Fire fighters were able to knock down most of the fire in the room; however, parts of the ceiling came down and showed that fire had spread to the next floor, so the fire fighters backed out and went into a defensive mode.

An investigation revealed that, during the evening's service, two 15-year-old girls had passed a note in their confirmation class stating that the church would be burned down by morning. The girls had used a lighter to ignite a candle and then had started a fire in some silk flowers in the powder room. From there, the fire spread up into the false ceiling and from one floor to the next and out through the roof. It also extended to the main worship area ceiling and caused the ceiling to burn and fall down. People in the area had smelled wood burning but assumed it was a fireplace. It is believed that the fire burned for at least 5 hours before it was discovered. The structure, valued at \$2.6 million, and its contents, valued at \$1.9 million, were completely destroyed. Two fire fighters were injured when they slipped on ice. The two girls were sentenced to 100 hours of community service to the church, probation for one year, and \$2,000 in restitution.

Annex C Basics of Fire and Fire Protection Systems

This annex is not a part of the requirements of this NFPA document but is included for informational purposes only.

C.1 Classification of Fires. Most fires that occur in cultural resource properties can be expected to fall into one or more of the following categories:

- (1) Class A fires involve ordinary combustible materials, such as paper, wood, and textile fibers, where a cooling, blanketing, or wetting extinguishing agent is needed.
- (2) Class B fires involve oils, greases, paints, and flammable liquids, where a smothering or blanketing action is needed for extinguishment.
- (3) Class C fires involve live electrical equipment, where a non-conducting gaseous clean agent or smothering agent is needed.

C.2 Fire Detection and Alarm Systems. Technology is available to customize a fire detection system for the particular needs of specific properties. Early detection of fires affords the opportunity for occupant intervention and potentially faster response by automatic fire suppression.

C.3 Glossary of Fire Protection Systems. Table C.3(a), Table C.3(b), Table C.3(c), and Table C.3(d) describe detection, alarm, and extinguishing systems that are appropriate for use in cultural resource properties. Included are comments about the intended or optimum applications of each system and recommendations for system applications. Insofar as possible, nontechnical terminology has been used so that the information presented can be readily understood by persons who have been delegated fire safety responsibility.

Table C.3(a) Classification of Fire Detection Systems by Method of Detection

Type	Description	Comments
Smoke detection systems	<p>These systems use devices that respond to the smoke particles produced by a fire. They operate on the ionization, photoelectric, cloud chamber, or other smoke particle analysis principle of operation. Spot-type smoke detectors use either the ionization or the photoelectric principle of operation. Line-type (also called linear beam type) smoke detectors use the photoelectric principle. Aspiration-type smoke detectors use either ionization, photoelectric, cloud chamber, laser, or other particle analysis principle of operation.</p>	<p>These systems are intended for early warning. Some are designed for installation in ventilation ducts. (<i>See NFPA 72.</i>)</p> <p>Properly installed, smoke detectors can detect smoke particles in very early stages of fire in the areas where they are located. The selection of a particular detector or mixture of or types of detectors should be made by a fire protection engineer and based on building and fire-load conditions.</p>
Heat detection systems	<p>These systems use heat-responsive devices of either the spot or line type. They are mounted on exposed ceiling surfaces or on a sidewall near the ceiling. Heat detectors are designed to respond when the operating element reaches a predetermined temperature (fixed temperature detector), when the temperature rises at a rate exceeding a predetermined value (rate-of-rise detector), or when the temperature of the air surrounding the device reaches a predetermined level, regardless of the rate of temperature rise (rate compensation detector).</p> <p>Some devices incorporate both fixed temperature and rate-of-rise detection principles. Spot-type detectors are usually small devices a few inches in diameter. Line-type detectors are usually lengths of heat-sensitive cable or small bore metal tubing.</p>	<p>These systems are relatively low cost. They cannot detect small, smoldering fires. Line-type detectors can be installed in a relatively inconspicuous manner by taking advantage of ceiling designs and patterns. (<i>See NFPA 72.</i>)</p> <p>The air temperature surrounding a fixed temperature device at the time it operates usually is considerably higher than the rated temperature, because it takes time for the air to raise the temperature of the operating element to its set point. This is called thermal lag.</p> <p>Rate compensation devices compensate for thermal lag and respond more quickly when the surrounding air reaches the set point. Given the monetary value and irreplaceable nature of typical museum collections, early-warning smoke detection systems should be considered for optimum protection. Where warranted, air-sampling-type detector systems should be considered. These systems are also less conspicuous and minimize disruption to architectural integrity.</p> <p>Proper selection of a particular detector or a mixture of detectors should be made by a fire protection engineer and based on building and fire-load conditions.</p>
Flame detection systems	<p>These systems use devices that respond to radiant energy visible to the human eye (approximately 4000 to 7000 angstroms) or to radiant energy outside the range of human vision [usually infrared (IR), ultraviolet (UV), or both]. Flame detectors are sensitive to glowing embers, coals, or actual flames with energy of sufficient intensity and spectral quality to initiate the detector.</p>	<p>Because flame detectors are essentially line-of-sight devices, special care should be taken in their application to ensure that their ability to respond to the required area of fire in the zone that is to be protected will not be unduly compromised by the permanent or temporary presence of intervening structural members or other opaque objects or materials. (<i>See NFPA 72.</i>)</p>

Table C.3(b) Classification of Fire Alarm Systems by Method of Operation

Type	Description	Comments
Protected premises fire alarm system	This system operates in the protected premises and is responsive to the operation of a manual fire alarm box, waterflow in a sprinkler system, or automatic detection of a fire by a smoke, heat, or flame-detecting system.	The main purpose of this type of system is to provide an evacuation alarm for the occupants of the building. Someone must always be present to transmit the alarm to fire authorities. <i>(See NFPA 72.)</i>
Auxiliary fire alarm system	This system utilizes a standard municipal fire alarm box to transmit a fire alarm from a protected property to municipal fire headquarters. The alarms are received on the same municipal equipment and are carried over the same transmission lines as are used to connect fire alarm boxes located on streets. Operation is initiated by the local fire detection and alarm system installed at the protected property.	Some communities accept this type of system, but others do not. <i>(See NFPA 72 and NFPA 1221.)</i>
Central station fire alarm system	This type of alarm system connects protected premises to a privately owned central station, monitors the connecting lines constantly, and records any indication of fire, supervisory, or other trouble signals from the protected premises. A central station is listed and is required to provide a certificate when providing central station services. When a signal is received, the central station takes such action as is required, such as informing the municipal fire department of a fire or notifying the police department of intrusion.	This is a flexible system. It can handle many types of alarms, including trouble within systems at protected premises. <i>(See NFPA 72.)</i>
Remote supervising station fire alarm system	This system connects protected premises over telephone lines to a remote station, such as a fire station or a police station. It includes a separate receiver for individual functions being monitored, such as fire alarm signal or sprinkler waterflow alarm. Normally these systems are located at the local jurisdiction's communications center; however, a listed central station can provide remote supervising station services.	<i>(See NFPA 72.)</i>
Proprietary fire alarm system	This system serves contiguous or noncontiguous properties under one ownership from a supervising station at the protected property. It is similar to a central station system but is owned by the protected property.	This system requires 24-hour attendance at the proprietary supervising station. <i>(See NFPA 72.)</i>
Emergency voice/alarm communication systems	This system is used to supplement any of the other systems listed in this table by permitting voice communication throughout a building so that instructions can be given to building occupants. During a fire emergency, prerecorded messages can be used to instruct the occupants to take emergency action, or fire department personnel can transmit live messages, or both.	<i>(See NFPA 72.)</i>

Table C.3(c) Classification of Fire Detection and Alarm Systems by Type of Control

Type	Description	Comments
Conventional system	This type of fire detection system utilizes copper wire to interconnect all initiating devices and notification appliances to the fire alarm control panel. The wiring must be installed in a closed-loop fashion for each zone circuit to ensure proper electrical supervision or monitoring of the integrity of the circuit conductors for integrity.	This is the most common type of fire alarm system. It provides basic alarm, trouble, and supervisory signal information and is used for small- to medium-size systems. These systems provide limited information such as the zone in alarm.
Addressable system	This system utilizes initiating devices and control points, each assigned a unique three- or four-digit number that is the detector's "address." The fire alarm control panel's microprocessor is programmed with this address number. All activity by or affecting the device is monitored and recorded at the control panel.	This type of system provides more detailed information about alarm, trouble, or supervisory conditions. Essentially, the system is "zoned" by device rather than by an entire floor or area. The equipment for addressable systems is more costly, but generally installation costs are reduced substantially, operations are more flexible, and maintenance is more efficient.
Addressable analog system	This type of system is identical to the addressable system, with the exception that the smoke and heat detectors connected to the microprocessor are analog devices. The analog devices sense the fire signature and continuously send information to the control panel microprocessor, which determines the sensitivity, alarm point, and maintenance window of the analog device. Accordingly, this system is also called "intelligent" or "smart."	Analog systems provide the maximum flexibility and information that can be obtained from a fire alarm system. These computer-based systems do require sophisticated technical expertise to maintain and service, so this should be considered in the design process. Addressable analog fire detection systems allow for the execution of preprogrammed sensitivity levels for smoke detectors based on the time of day or days of the week, ranging from a low-sensitivity level during the period the premise is occupied to a high-sensitivity level when only employees are present or the protected premise is vacant.
Wireless system	This system uses battery-powered initiating devices, which transmit the alarm or trouble signal to a receiver/control panel. Each initiating device can be individually identified by the control panel for annunciation purposes.	The battery in each initiating device will last for a minimum of 1 year but needs to be replaced whenever the initiating device transmits a battery depletion signal to the control panel. Wireless systems can be used where it is not possible or feasible to install the electrical cable needed by hard-wired systems. The notification appliances are still required to be wired to a fire alarm control panel. Typically these systems are used in conjunction with one of the systems described above.

Table C.3(d) Glossary of Fire Extinguishing Systems

Type	Description	Comments
Wet pipe automatic sprinkler system	This permanently piped water system is under pressure and uses heat-actuated sprinklers. When a fire occurs, the sprinklers exposed to the high heat operate and discharge water individually to control or extinguish the fire.	This type of system automatically detects and controls fire. It should not be installed in spaces subject to freezing and might not be the best choice in spaces where the likelihood of mechanical damage to sprinklers or piping is high, such as in low-ceiling areas, and could result in accidental discharge of water. Where there is a potential for water damage to contents, such as books, works of art, records, and furnishings, the system can be equipped with mechanically operated on-off or cycling heads to minimize the amount of water discharged (see on-off automatic sprinkler system). In most instances, the operation of only one sprinkler will control a fire until the arrival of fire fighters. Often, the operation of a sprinkler system will make the use of hose lines by fire fighters unnecessary, thus reducing the amount of water put onto the fire and the subsequent amount of water damage. (See NFPA 13 and NFPA 22.)
Preaction automatic sprinkler system	This system employs automatic sprinklers attached to a piping system containing air that might or might not be under pressure, with a supplemental fire detection system installed in the same area as the sprinklers. When the fire detection system is actuated by a fire, a valve opens allowing water to flow into the sprinkler system piping and to be discharged from any sprinklers that are opened subsequently by the heat from the fire.	This system automatically detects and controls fire and can be installed in areas subject to freezing with the exception of a special listed pre-primed preaction system. It minimizes the potential for accidental discharge of water due to mechanical damage to sprinklers or piping and is used in earthquake zones or where system leaks could pose an unacceptable risk to collections that are especially sensitive to water damage, such as pen and ink drawings on paper or works of art made with water-soluble materials. The overall reliability of this system is lower than that of a wet pipe system in several respects: failure of the actuation system would prevent operation of the sprinklers, except by manual operation of the system control valve, a preaction system requires a significantly higher level of regular maintenance to prevent additional potential failure modes; and the long-term presence of oxygen combined with water trapped at low-points or at water traps created by rolled groove joints or moisture in the compressed air used to maintain pressure in the system can cause severe corrosion in steel sprinkler system piping. In order to minimize the potential for pinhole leaks or corrosion related obstructions in the system, steps should be taken to eliminate the potential for trapped water in the piping, to limit the introduction of fresh, oxygen laden, water into the system, and to ensure regular inspections of the interior of steel piping for indications of corrosion. (See NFPA 13 and NFPA 22.)
On-off automatic sprinkler system	This system is similar to the preaction system, except that the fire detector operation acts as an electrical interlock, causing the control valve to open at a predetermined temperature and close when normal temperature is restored. If the fire rekindles after its initial control, the valve reopens, and water again flows from the opened sprinklers. The valve continues to open and close in accordance with the temperatures sensed by the fire detectors.	In addition to the favorable feature of the automatic wet pipe system, these systems have the ability to automatically stop the flow of water when it is no longer needed, thus eliminating unnecessary water damage. (See NFPA 13 and NFPA 22.)

(continues)

Table C.3(d) *Continued*

Type	Description	Comments
Dry pipe automatic sprinkler system	This type of system employs automatic sprinklers attached to a piping system that contains air under pressure. When a sprinkler operates, the air pressure is reduced, thus allowing the dry pipe valve to open and water to flow through any opened sprinklers. This system must be installed properly to avoid possible corrosion issues.	<i>(See the comments for wet pipe automatic sprinkler system.)</i> This system can protect areas subject to freezing. Water supply must be in a heated area. The long-term presence of oxygen combined with water trapped at low-points or at water traps created by rolled groove joints or moisture in the compressed air used to maintain pressure in the system can cause severe corrosion in steel sprinkler system piping. In order to minimize the potential for pinhole leaks or corrosion-related obstructions in the system steps should be taken to eliminate the potential for trapped water in the piping, to limit the introduction of fresh, oxygen laden, water into the system, and to ensure regular inspections of the interior of steel piping for indications of corrosion. <i>(See NFPA 13 and NFPA 22.)</i>
Standpipe and hose system	This is a piping system in a building to which hoses are connected for emergency use by building occupants or the fire department.	This system is a desirable complement to an automatic sprinkler system. Staff must be trained to use hose effectively. <i>(See NFPA 14.)</i>
Clean agent system	This permanently piped system uses a limited, stored supply of a gaseous extinguishing agent under pressure and discharge nozzles to totally flood an enclosed space. The extinguishing agent is released automatically by a suitable detection system, and fire is extinguished by chemical or mechanical means.	This system causes no agent damage to protected books, manuscripts, records, paintings, or other valuable objects; it also leaves no agent residue. Clean agents are low in toxicity, but the products of decomposition of some agents during a fire could be hazardous. Therefore, the fire area should be promptly evacuated when a fire alarm sounds prior to agent discharge. Clean agents might not extinguish deep-seated fires in ordinary solid combustibles, such as paper and fabrics, but they are effective on surface fires in these materials. These systems need special precautions to avoid damaging effects caused by their extremely rapid release. The high-velocity discharge from nozzles might be sufficient to dislodge substantial objects directly in the path. Where carbon dioxide systems are used, personnel should evacuate before agent discharge to avoid suffocation. <i>(See NFPA 12 and NFPA 2001.)</i>
Dry chemical system	This permanently piped system discharges a dry chemical from fixed nozzles by means of an expellant gas. The system either totally floods an enclosed space or applies the dry chemical directly onto the fire in a local application. The dry chemical extinguishes fires by the interaction of the dry chemical particles to stop the chain reaction that takes place in flame combustion. The dry chemical is released mechanically or with a suitable detection system.	Because this system leaves a powdery deposit on all exposed surfaces in and around the hazard being protected, it requires cleanup. This type of system provides excellent protection from fire when it is installed in the ducts and hood over cooking equipment such as deep fat fryers, range griddles, and broilers that could be a source of ignition. It might not extinguish deep-seated fires, but it is effective on surface fires. <i>(See NFPA 17.)</i>

(continues)

Table C.3(d) *Continued*

Type	Description	Comments
High-expansion foam system	This fixed extinguishing system generates a foam agent for total flooding of confined spaces and for volumetric displacement of vapor, heat, and smoke. It acts on a fire in the following ways: (1) Prevents free movement of air (2) Reduces the oxygen concentration at the fire (3) Cools (4) Is released automatically by a suitable detection system	Where personnel might be exposed to a high-expansion foam discharge, suitable safeguards should be provided to ensure prompt evacuation of the area. The discharge of large amounts of high-expansion foam can inundate personnel, blocking vision, making hearing difficult, and creating discomfort in breathing. It also leaves residue and requires cleanup. Properly designed, a high-expansion foam system used in conjunction with water sprinklers provides more positive control and extinguishment than either extinguishment system used independently. (<i>See NFPA 11.</i>)
Wet chemical extinguishing system	This system uses a liquid agent usually released by automatic mechanical thermal linkage to extinguish fire by chemical or mechanical means. It is effective for restaurant, commercial, and institutional hoods, plenums, ducts, and associated cooking appliances.	This system leaves agent residue that is confined to the protection area(s) and requires cleanup. It is excellent for service facilities having range hoods and ducts. (<i>See NFPA 17A.</i>)
Fine water mist system	In general, this piped system or modular, pressurized container system delivers a fine water mist. Water droplet size ranges to a maximum 1000 µm.	A distribution system connected to a water supply or water and atomizing media supplies that is equipped with one or more nozzles capable of delivering water mist intended to control, suppress, or extinguish fires and that has been demonstrated to meet the performance requirements of its listing and NFPA 750. (<i>See NFPA 750.</i>)

Annex D Security Systems

This annex is not a part of the requirements of this NFPA document but is included for informational purposes only.

D.1 Introduction.

Fire protection and security are interrelated. The installation of an electronic security system within the premises is part of the built environment. How it operates with other systems within the same building is integral to the complete protection platform that could be installed. Owners and operators of cultural facilities should involve professionals with experience in the application of security features and systems to buildings. This annex will provide a brief overview of premises security systems that are covered by two NFPA documents: NFPA 730 and NFPA 731.

The practitioner needs to obtain a copy of both for a full understanding of security needs and practices. NFPA 909 references NFPA 730 and has adopted NFPA 731 by reference. As such, the designer of premises security systems should be familiar with NFPA 730 and NFPA 731, as well as many other publications available through the literature. Practitioners need to be as familiar with the concepts and principles of security as fire protection engineers are with their skill set. The consequences of a poor design for security systems can be just as devastating to the collection, property, or building owner as there would be from an inadequate fire protection design.

This annex is intended to only cover security systems. A description of physical security elements can be found in 8.3.5.

Security systems for the purpose of this annex can be separated into the following three broad categories:

- (1) Intrusion detection

- (2) Access control
- (3) Closed-circuit TV

D.2 Intrusion Detection. Intrusion detection systems can protect both the exterior and interior of premises. A vulnerability assessment as discussed in 5.2.2 should be performed to determine the level of detection to be provided.

D.2.1 Exterior Detection. Exterior sensors should have a high probability of detection for all types of intrusion and a low unwanted-alarm rate for all expected environmental and site conditions. [*See Table D.2.1(a).*] The designer, in addition to the threat and risk assessment, needs to take into consideration the cost of the detection, both the equipment and its installation, as well as the cost of maintaining the equipment after the installation. [*See Table D.2.1(b).*]

Consideration should also be given to the local environment and the probability of the system having false alarms due to the detection device(s) that were installed. [*See Table D.2.1(c).*]

Exterior devices include the following:

- (1) Audio
- (2) Contacts
- (3) Motion detection
- (4) Fence-strain systems
- (5) Electric-field systems
- (6) Capacitance-sensor system
- (7) Leaky coaxial
- (8) Stress sensors
- (9) Shock sensors
- (10) Photo-electric cell

Audio. Audio or sound detectors can be used effectively to protect enclosed areas, vaults, warehouses, and similar enclosures. Microphone speaker sensors are installed on walls and ceilings of the protected area. The sensitivity of the system can be adjusted.

Contacts. Contacts should be listed in accordance with UL 634. Depending on the application, the designer can use either a flush or surface contact. The contact can be “balanced” for high security or “wide-gap” if used on a large door or fence. The designer should consult with the manufacturer of the contact to specify the proper contact application.

Motion Detection. The principal type of motion detection used for exterior detection is the microwave. Microwave detection sensors are categorized as bistatic or monostatic.

Bistatic sensors use transmitting and receiving antennas located at opposite ends of the microwave link. Monostatic use the same antenna.

Care should be taken when selecting a microwave detection system so that the field of detection does not extend beyond the area to be covered. Microwave energy can extend beyond the intended target area and cause false alarms from movement outside of the field of coverage. [See Figure D.2.1(a).]

Fence-strain system. The fence-strain system uses cables as transducers that are uniformly sensitive along their entire length. They generate an analog voltage when subject to mechanical distortions or stress resulting from fence motion. [See Figure D.2.1(b).]

Electric-field system. An electric-field system consists of an alternating-current field generator, one or more field wires, and one or more sensing wires and a signal processor. The generator excites the field wires around which an electrostatic field pattern is created. The electrostatic field induces electrical

signals in the sense wires, which are monitored by the signal processor. [See Figure D.2.1(c).]

Capacitance-Sensor System. A capacitance-sensor or proximity sensor measures the electrical capacitance between the ground and an array of sense wires. Any change in capacitance caused by an intruder approaching or touching one or more of the sense wires initiates an alarm. [See Figure D.2.1(d).]

Leaky Coaxial Cable System. Leaky coaxial cable (LCX) has been used for a number of years for perimeter protection. This method is also referred to as a ported system. The system involves lining the perimeter with two parallel LCX cables buried just below the surface of the ground. The depth is determined by the manufacture and coverage the designer wishes to obtain. These cables are generally buried in soil but can also be placed underneath asphalt or concrete.

The LCX cable is slotted or ported so as to allow RF energy to be released. Two LCX cables are run in parallel, one for transmission and the second for receiving. This generates a constant volume of electric magnetic (EM) field above the ground. Movement of objects within the EM field will cause a disturbance, leading to an alarm activation. [See Figure D.2.1(e).]

Stress sensor. Reserved.

Shock sensor. Reserved.

Photo-electric cell. Reserved.

D.2.2 Interior Detection. Interior detection includes both perimeter and space detection. Perimeter detection is installed along the perimeter of the premises — doors, windows, walls, and roofs. Space detection provides coverage within the interior or space of the premises. [See Table D.2.2(a).]

Table D.2.1(a) Sensor Performance — Probability of Detection by Exterior Sensors

Type of Sensor	Intruder Technique											
	Slow walk	Walking	Running	Crawling	Rolling	Jumping	Tunneling	Trenching	Bridging	Cutting	Climbing	Lifting
Fence mounted	N/A	N/A	N/A	N/A	N/A	VH	VL	L	VL	M/H	H	M/H
Taut wire	N/A	N/A	N/A	N/A	N/A	VH	VL	VL	VL	H	H	H
Electric field	VH	VH	VH	H	VH	VH	VL	L	L	N/A	N/A	N/A
Capacitance	VH	VH	VH	H	H	VH	VL	L	L	N/A	N/A	N/A
Ported cable	H	VH	VH	VH	VH	H	M	VH	L	N/A	N/A	N/A
Seismic	H	VH	H	M	M	M	L	M	L	N/A	N/A	N/A
Seismic/magnetic	H	VH	H	M	M	M	L	M	L	N/A	N/A	N/A
Microwave	H	VH	H	M/H	M/H	M/H	VL	L/M	L	N/A	N/A	N/A
IR	VH	VH	VH	M/H	M/H	H	VL	L	VL	N/A	N/A	N/A
Video motion	H	VH	VH	H	H	H	VL	L/M	M	N/A	N/A	N/A

VL = very low, L = low, M = medium, H = high, VH = very high, N/A = not applicable

Source: Field Manual FM-3-19.30, Physical Security, Headquarters, Department of the Army, 2001, Table 6-1.

Editor’s Note: Exterior sensors must have a high probability of detection (PD) for all types of intrusion and have a low unwanted-alarm rate for all expected environmental and site conditions.

Unfortunately, no single exterior sensor that is presently available meets both these criteria. All are limited in their detection capability and all have high susceptibility to nuisance and environmental conditions.

Interior devices include the following:

- (1) Protective wiring
- (2) Foil
- (3) Traps
- (4) Contacts
- (5) Shock sensors
- (6) Glass break sensors
- (7) Sound detectors
- (8) Motion detectors
- (9) Photo electric cells

Protective wiring. Protective wiring is primarily found in older systems. The designer might find these methods useful for the protection of vents, skylights, and high windows.

Table D.2.1(b) Economic Considerations

Type of Sensor	Equipment	Installation	Maintenance
Fence mounted	L	L	L
Taut wire	H	H	M
Electric field	H	M	M
Capacitance	M	L	M
Ported cable	H	M	M
Seismic	M	M	L
Seismic/ magnetic	H	M	L
Microwave	M	M	L
IR	M	L	M
Video motion	M	L	M

L = low, M = medium, H = high

Source: *Field Manual FM-3-19.30, Physical Security*, Headquarters, Department of the Army, 2001, Table 6-3.

Editor's Note: The designer, in addition to the threat and risk assessment, needs to take into consideration the cost of the protection, both of the equipment and its installation, as well as the cost of maintaining the equipment after the installation. Depending on the threat, a particular method and equipment used for a power plant may not be required for a lumber storage yard.

Stacked Microwave Configuration

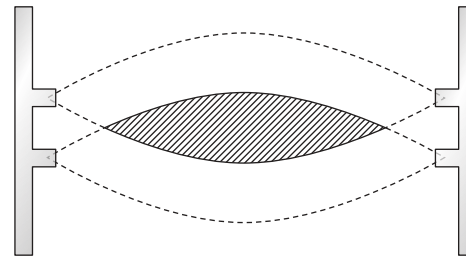

Typical Monostatic Microwave Sensor Detection Pattern

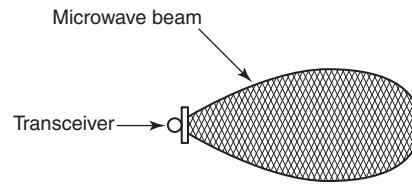

FIGURE D.2.1(a) Microwave.

Foil. Foil is rarely used today. Care should be taken before foil is applied to verify that the glass or object to be protected is free of breaks and is securely mounted to the structure. After installation, maintenance requirements can be high. [See Figure D.2.2(a). (Used with permission from Underwriters Laboratories Inc.)]

Traps. Traps include ball, barrier bar, and disconnecting. These are devices that are intended to be tripped or broken by an intruder within the space to be protected. These devices, in most cases, need to be set in place before the intrusion detection system is set and must be removed prior to the space being used. These devices can require a high level of maintenance.

Table D.2.1(c) Relative Susceptibility of Exterior Sensors to False Alarms

Type of Sensor	Intruder Technique										Overhead Power Lines	Buried Power Lines
	Wind	Rain	Standing water/runoff	Snow	Fog	Small Animals	Large Animals	Small Birds	Large Birds	Lightning		
Fence mounted	H	M	L	L	VL	L	M	L	L	L	VL	VL
Taut wire	VL	VL	VL	VL	VL	VL	L	VL	VL	VL	VL	VL
Electric field	M	L/H	VL	M	VL	M	VH	L	M	M	L	VL
Capacitance	M	M	VL	M	VL	M	VH	L	M	M	L	VL
Ported cable	VL	M	H	L	VL	VL	M	VL	VL	M	VL	L
Seismic M	L	L	L	VL	L	VH	VL	VL	L	L	M	
Seismic/ magnetic	M	L	L	L	VL	L	VH	VL	VL	H	M	H
Microwave	L	L	M/H	L/M	L	M/H	VH	VL	M	L/M	L	VL
IR	L	L	L	M	M	M	VH	L	M	L	VL	VL
Video motion	M	L	L	L	M/H	L	VH	VL	M	L	L	VL

VL = very low, L = low, M = medium, H = high, VH = very high

Source: *Field Manual FM-3-19.30, Physical Security*, Headquarters, Department of the Army, 2001, Table 6-2.

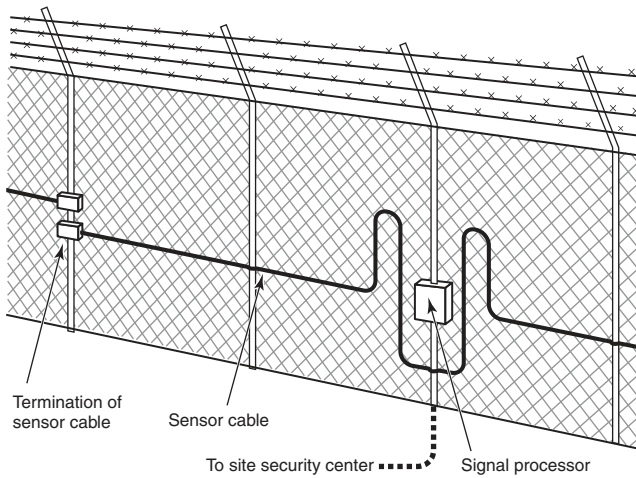

FIGURE D.2.1(b) Fence Strain System.

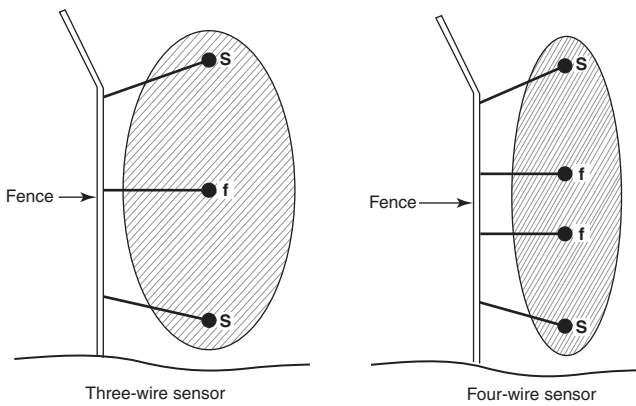

FIGURE D.2.1(c) Electric-Field System.

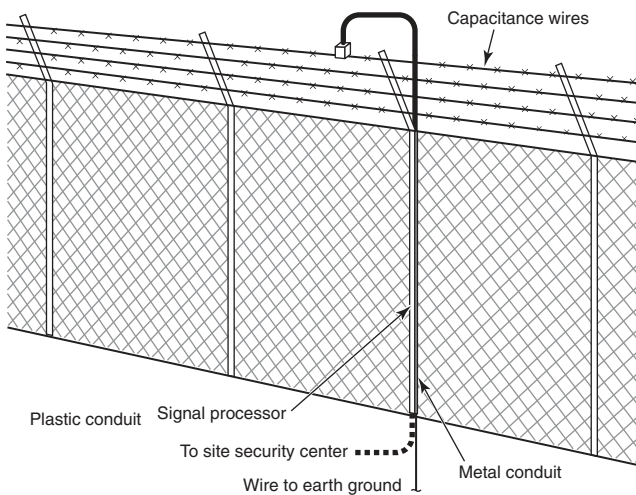

FIGURE D.2.1(d) Capacitance-Sensor System.

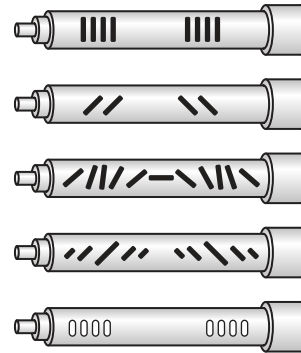
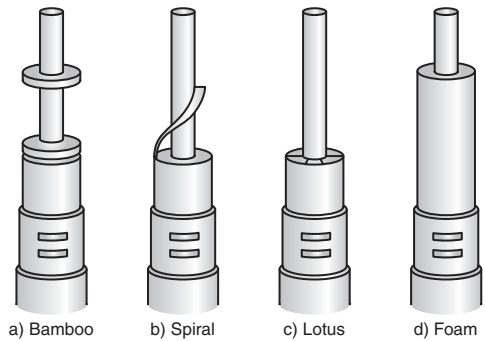
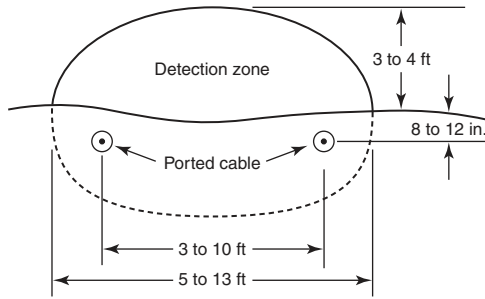

FIGURE D.2.1(e) Leaky Coaxial.

Contacts. Reserved. Figure D.2.2(b) and Figure D.2.2(c) depict typical contacts and magnetic contact mounting configurations, respectively. Table D.2.2(b) summarizes the advantages and disadvantages of door and window contacts.

Shock sensors. Shock sensors [see Figure D.2.2(d)] detect any vibration caused by attempted forced entry. The designer should take care in their application and avoid locations that are subject to high vibrations. Table D.2.2(c) summarizes the advantages and disadvantages of shock (vibration) sensors.

Glass break sensors. Glass break sensors [see Figure D.2.2(e)] are both audio (sound discriminators) and shock. They are activated by the frequency of breaking glass and the shock or vibration to the structure of the glass being broken. The use of glass break detectors has replaced the use of foil as the principal method of protecting glass. The designer should be aware of various films on the glazing material that can dampen the effectiveness of the detector.

Sound detector. Sound or audio detectors can be used effectively to protect enclosed areas, vaults, warehouses, and similar

enclosures. Microphone speaker sensors are installed on walls and ceilings of the protected area. The sensitivity of the system can be adjusted. Table D.2.2(d) summarizes the advantages and disadvantages of sound detection.

Photo-electric cells (PEC). Photo-electric cells are depicted in Figure D.2.2(f). Table D.2.2(e) summarizes the advantages and disadvantages of photo-electric cells.

Motion detectors. Motion detectors include microwave, passive infrared (PIR), two or more technologies (hybrid), and video motion. There is also ultrasonic. Due to a high probability of false alarms, this method of space detection is rarely used today.

The designer must take care in selecting and placing these detectors. Improper placement of these otherwise effective devices can cause false and unwanted alarms.

Microwave. Microwave detectors [see Figure D.2.2(g)] used for interior detection are typically monostatic. The shape of the transmitted beam is a function of the antenna configuration. A variety of detection patterns can be generated. Movement in the area will produce a Doppler frequency shift in the reflected signal and will produce an alarm if the signal satisfies the sensor's alarm criteria.

Microwave detectors are best at detecting movement toward and away from the source. The designer should use care in selecting and placing this detection technology. Microwave energy can pass through glass doors and windows, as well as lightweight walls or partitions constructed of plywood, plastic, or fiberboard. Microwave detectors are also susceptible to fluorescent lighting.

Passive infrared. Passive infrared motion sensors detect a change in the thermal energy pattern caused by a moving intruder. The sensor's detection pattern is determined by arrangement of lenses or reflectors.

The pattern is not continuous but consists of a number of fingers, one for each mirror or lens segment. Numerous detection patterns are available, and the designer should select the one that meets the requirements of the space to be protected.

PIR motion sensors are best at detecting motion across the field of view. PIR detectors should not be pointed toward a heat source or outside window that can catch the lights of traffic. Under no circumstances is a PIR detector that is listed for security to be used as part of an automatic fire detection system. [See Figure D.2.2(h).]

Video motion. Video motion detection (VMD) combines space protection and closed-circuit TV (CCTV). A camera is mounted to cover the field of view. The active component for the VMD is not within the camera but is a part of the processing equipment that is located at the receiving and viewing end of the system.

During the programming of the system, active cells are selected within the field of view that is displayed by the camera to the monitor. When an object passes through an active field, the VMD will detect the movement and trigger an alarm. Detection is caused by the stable static view being disturbed by the motion through the active cells within the field of view. [See Figure D.2.2(i). (Source: Adapted from *Video Motion Detectors*, DigiSpec Inc., Humble, Texas 2009; (b) adapted from *Video Motion Detectors, VMD-1001 Digital Video Motion Detector Operations Manual*, Humble, Texas 2009.)]

D.2.3 UL Certification. Depending on the value of the property being protected, the designer can specify that the installed intrusion detection system be certified by Underwriters Laboratories, Inc. UL provides third-party oversight and review of security systems installed in accordance with UL 681, *Standard for Installation and Classification of Burglar and Holdup Alarm Systems*. UL 681 provides a number of levels of protection or extents that the designer can specify. As the extent of protection increases, the level of detection within the premises increases. (See Table D.2.3.)

Table D.2.2(a) Factors Affecting the Operation of Area Protection Devices

Factor	Photoelectric	Audio	Ultrasonic	Microwave	Passive IR
Absorption of Energy by Objects	No	Yes	Yes	No	No
Drafts/Air Movement	No	No	Yes	No	No
Blocking of Energy by Objects	Yes	No	Yes	Yes	Yes
Cold/Heat Sources	No	No	Maybe	No	Yes
Fluorescent Lights	No	No	No	Yes	No
Hanging Objects	No	No	Yes	Maybe	Maybe
Loose Fitting Doors and Windows	No	Yes	Yes	Yes	No
Movement Outside Protected Area	No	No	No	Yes	No
Moving Machinery, Fan Blades, etc.	No	Yes	Yes	Yes	Maybe
Noise	No	Yes	Maybe	No	No
Radar	No	No	No	Yes	No
Radio Frequency Interference	No	No	Maybe	Maybe	No
Small Animals	Yes	Maybe	Yes	Maybe	Maybe
Smoke, Dust and Steam	Yes	No	Maybe	No	Maybe
Sunlight and Moving Headlights	Maybe	No	No	No	Yes

No—Indicates no problem.

Yes—Indicates the potential for false alarm or improper operation.

Maybe—Indicates uncertainty, but which can usually be corrected by the proper placement of the detector.

Source: Richard L. Sampson (Chairman), *A Practical Guide to Central Station Burglar Alarm Systems*, Central Station Alarm Association, Bethesda, MD, 1997, Table 9

Table D.2.2(b) Advantages and Disadvantages of Door and Window Contacts

Advantages	Disadvantages
Consistently provides the most trouble-free service.	Is costly to install where there are many entry points to the protected area.
Causes few, if any, false or unwanted alarms.	Is easily compromised when improperly applied. May allow unprotected soft walls or ceilings to be penetrated without activating the intrusion detection system. May be defeated by bridging the circuits.

Source: Paul A. Rosenberg, *Facility Security: New Threats, New Strategies*, NFPA, Quincy, MA, 2002, p. 142.

Table D.2.2(c) Advantages and Disadvantages of Shock (Vibration) Sensors

Advantages	Disadvantages
Is economical and easily installed.	Can be used only in areas where a minimum of vibration exists.
Has flexibility in application.	Is not satisfactory where high vibrations are encountered, especially in proximity to heavy construction, railroad, automotive, and truck traffic. Cannot be used effectively outdoors.

Source: Paul A. Rosenberg, *Facility Security: New Threats, New Strategies*, NFPA, Quincy, MA, 2002, p. 145.

Table D.2.2(d) Advantages and Disadvantages of Sound Detection

Advantages	Disadvantages
Is economical and easily installed.	Can be used only in enclosed areas where a minimum or extraneous sound exist.
Allows the use of microphone speakers to monitor sounds coming from the protected area.	Is not satisfactory where high noise levels are encountered, especially in proximity to aircraft and railroad traffic. Cannot be used effectively outdoors. Should not be used in areas where sensitive, classified discussions occur, unless the system is designed to prevent its use as a clandestine listening device.

Source: Paul A. Rosenberg, *Facility Security: New Threats, New Strategies*, NFPA, Quincy, MA, 2002, p. 144.

Table D.2.2(e) Advantages and Disadvantages of Photo-Electric Cells (PEC)

Advantages	Disadvantages
Affords effective, reliable notice of intrusion when properly employed.	Is limited to those locations where it is not possible to bypass the beam by crawling under or over it.
Is useful in open portals or driveways where obstructions cannot be used.	Can be subject to interruption of light beam by fog, smoke, dust, snow, and rain in sufficient density.

Source: Paul A. Rosenberg, *Facility Security: New Threats, New Strategies*, NFPA, Quincy, MA, 2002, p. 144.

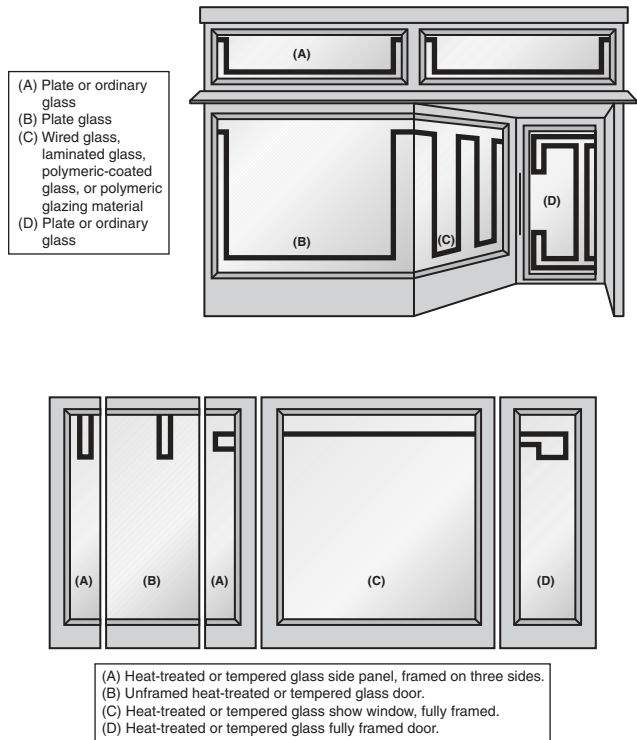

FIGURE D.2.2(a) Foil.

D.3 Access Control. Access control systems can control, restrict, and track the flow of personnel and visitors through a protected premises. The components of an access control system are as follows:

- (1) Controllers
- (2) Readers and Credentials

Controllers. The controller is the front end of most access control systems. The controller can be a stand-alone unit or integrated with a computer. The controller contains information related to time, schedules, access groups, and enrolled personnel. Before laying out any access control system, the designer should be familiar with the operating protocols of the premises.

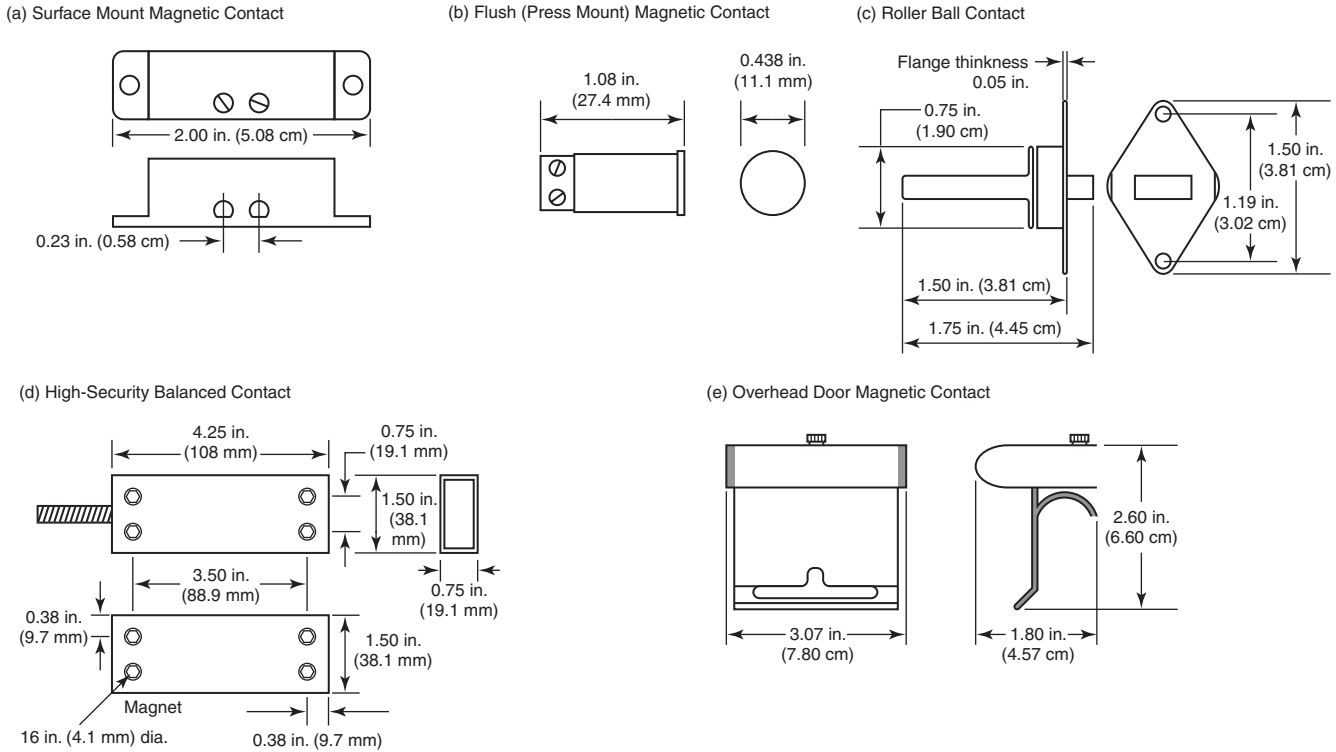

FIGURE D.2.2(b) Typical Contacts.

Readers and Credentials. Readers and credentials are closely related. The type of reader selected will dictate the type of credential used, and vice versa. Card readers can be of the following types:

- (1) Hollerith
- (2) Magnetic stripe
- (3) Barium ferrite (BaFe)
- (4) Radio-frequency identification (RFID)
- (5) Bar code
- (6) Wiegand

Table D.3(a) provides a comparison of reader/card technologies.

Hollerith. Limited to hotel guestroom access today, the Hollerith access control card is one that has small holes that can be read by contact brushes or a light source. This card received its name from Herman Hollerith, inventor of the computer punch card. Table D.3(b) summarizes the advantages and disadvantages of Hollerith cards.

Magnetic Stripe. The magnetic card reader is still a commonly used technology. A number of standards from the International Standards Organization (ISO) and American National Standards Institute (ANSI) cover data formats found on these cards. Magnetic cards have a low coercivity, and thus could be damaged by a small magnet. Table D.3(c) summarizes the advantages and disadvantages of magnetic stripe cards.

(e) Overhead Door Magnetic Contact

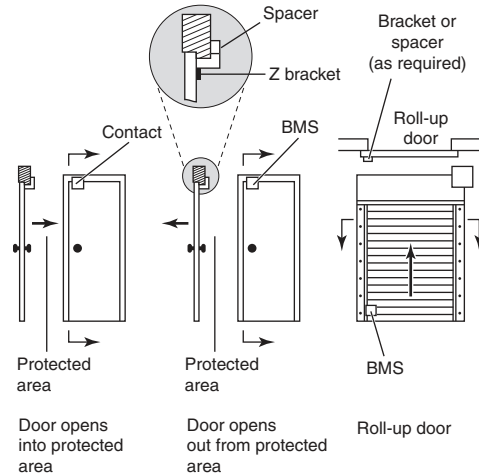
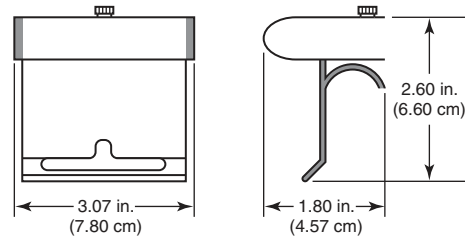

FIGURE D.2.2(c) Magnetic Contact Mounting Configurations.

Barium ferrite. The barium ferrite (BaFe) card is made up of a laminate of three-ply from two outer layers of PVC, which enclose a barium ferrite mixture that is capable of being magnetized. The BaFe card is encoded by passing the card through a strong magnetic field, which causes the barium ferrite beads within the card to be arranged to produce unique magnetic field patterns. Table D.3(d) summarizes the advantages and disadvantages of barium ferrite cards.

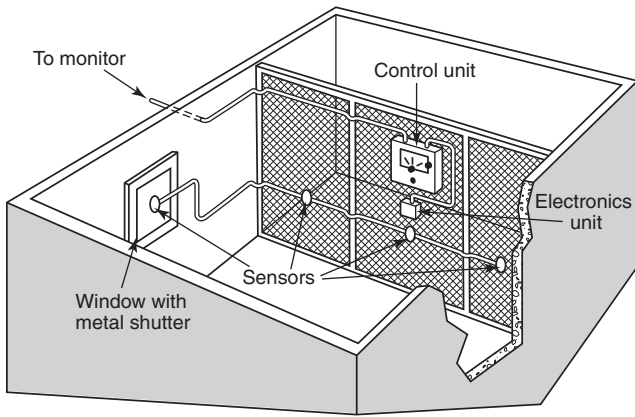

FIGURE D.2.2(d) Shock (Vibration) Sensors.

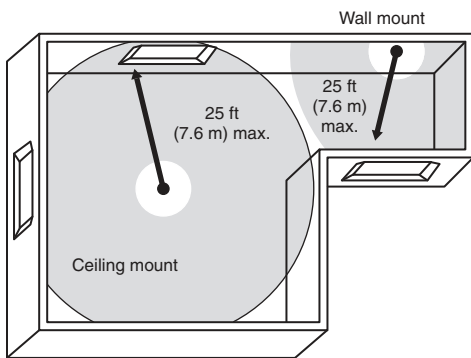
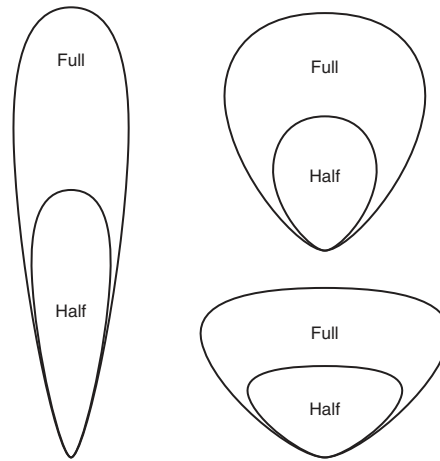

FIGURE D.2.2(e) Glass Break Sensors.

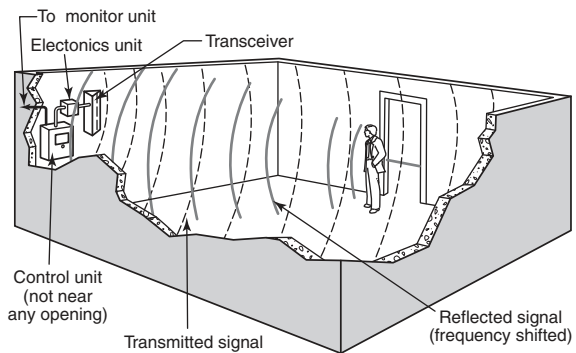

FIGURE D.2.2(g) Microwave.

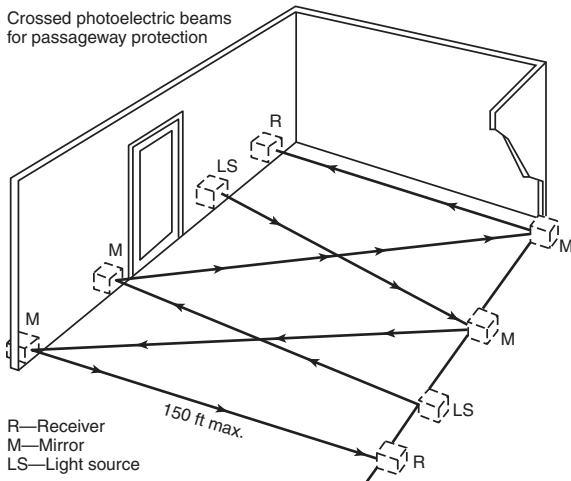

FIGURE D.2.2(f) Photo Electric Cells (PEC).

Radio-frequency identification. Radio-frequency identification (RFID) is a wireless means of transmitting data from the reader to the card or tag. [See Figure D.3(a).] Like the magnetic stripe technology, access control is just one of the uses of RFID. If this technology is to be used, the designer needs to determine the range that the system must achieve. This will determine if a passive or active system is to be used. Table D.3(e) summarizes RFID characteristics Table D.3(f) summarizes RFID frequency

band characteristics. Table D.3(g) summarizes RFID frequency applications.

Proximity. The proximity card has an embedded circuit that transmits frequencies detectable by the card reader. Proximity cards, key fobs, or tokens can either be passive or active. Active cards have a longer read distance but have a finite life due to the internal battery. Table D.3(h) summarizes the advantages and disadvantages of proximity cards.

Bar code. Bar codes come in a number of formats. They are standardized so that they can be used for a number of applications. Bar codes were first patented in 1952. Their first commercial application was for point-of-sale checkout in grocery outlets. The universal grocery products identification code (UGPIC) was the first standardized code. Depending on the manufacture of the bar code reader, system might be able to decode a variety of bar code formats. Table D.3(i) summarizes the advantages and disadvantages of bar codes.

Wiegand. The Wiegand cards use a patented technique that uses an array of wires that are embedded into the card in two tracks. These wires can store a magnetic charge within their outer sheath. The wires, which are located a specific points, act as a signal generator when the card is energized by the reader. The order and spacing of the wires create the unique code for each card. Table D.3(j) summarizes the advantages and disadvantages of Wiegand cards.

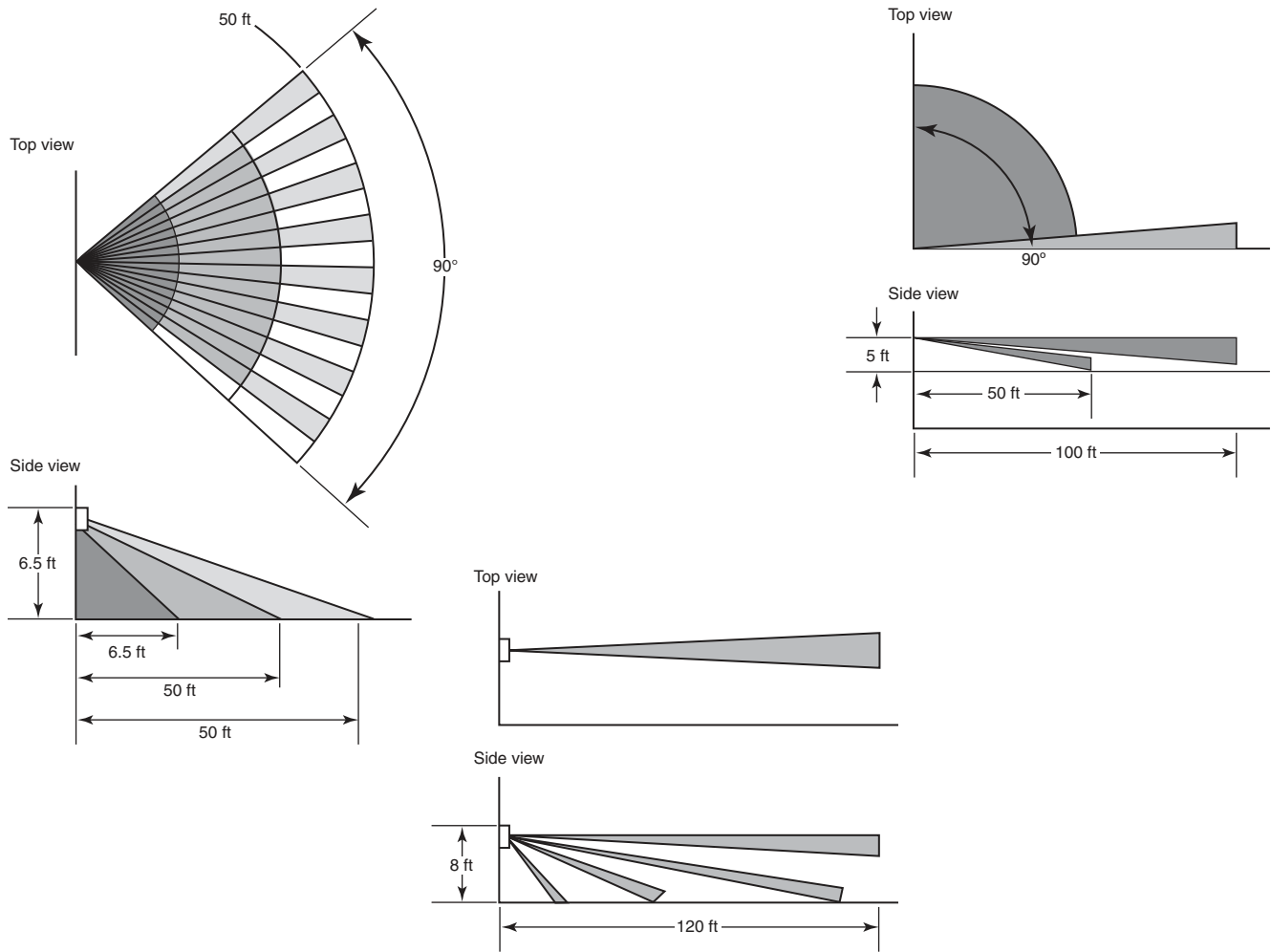

FIGURE D.2.2(h) Passive Infrared (PIR).

For enhanced security the designer can use biometric readers, which require a unique data set from the holder of credentials. Biometric credentials can be one of the following:

- (1) Hand/finger geometry
- (2) Fingerprints
- (3) Handwriting
- (4) Eye scan
- (5) Voice recognition
- (6) Face recognition

Depending on the technology to be used, and the security objectives to be achieved, the system can be set to minimize false accepts (Type I error) or to minimize false rejects (Type II error). A system cannot be set to accept both. [See Figure D.3(b).]

Face/finger geometry. Hand/finger geometry uses a three-dimensional picture of the hand. The system measures the required data points and creates a model of the hand, called a feature vector. During verification the feature vector is compared to the hand being placed in the reader. If the two compare within allowable tolerances, verification will be achieved. Table D.3(k) summarizes the advantages and disadvantages of hand/finger geometry.

Fingerprints. Fingerprints have been used to identify humans for over 100 years. It is estimated that there are 10 to the 48th power of possible fingerprint patterns. This method of identification is becoming widely used for the securing of computers and workstations. Fingerprint readers can be optical, ultrasound, or direct imaging. Table D.3(l) summarizes the advantages and disadvantages of fingerprints.

Handwriting. The banking industry has used handwriting verification for many years. [See Figure D.3(c).] Automated systems look for a number of data points that are used for verification. There are a number of models that are used to evaluate the authenticity of the signature. Table D.3(m) summarizes the advantages and disadvantages of handwriting.

Eye scan. The pattern of blood vessels in the retina of the eye is unique. No two humans have the same pattern. Each iris is also unique in its color and structure, and the eye scan devices can include retina or iris. Eye scans are seen as being invasive, so while they provide a high level of security, user acceptance is mixed. Table D.3(n) summarizes the advantages and disadvantages of eye scans.

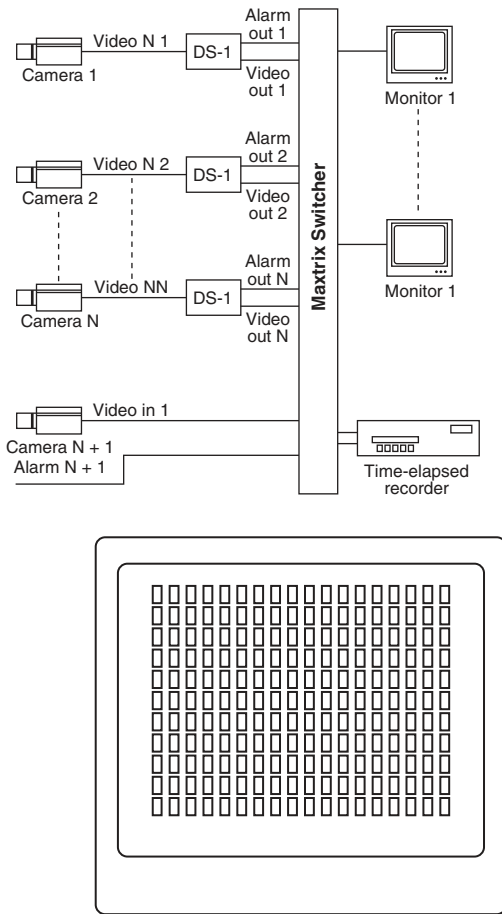

FIGURE D.2.2(i) Video Motion Detection (VMD).

Voice recognition. Systems use a voice synthesizer to compare voice patterns, such as air pressure, voice pitch period, resonant frequencies of the vocal track, and vibration caused by the movement of the larynx to that which was captured during enrollment. Table D.3(o) summarizes the advantages and disadvantages of voice recognition.

Face recognition. This method is noninvasive and can be used at protected premises as a method to restrict access to a secure area. This technology is a concern of privacy rights groups when used in part with a CCTV system to scan people in public places without their consent. Table D.3(p) summarizes the advantages and disadvantages of face recognition.

D.4 Video Surveillance (CCTV). Video surveillance systems, or CCTV, allow one to view and capture images from a protected location. The basic CCTV system is made up of a camera and monitor. If the image is to be captured for future viewing, then a recording device is required. CCTV systems can vary from a single camera with no recording device, perhaps located in a small mercantile shop for the manager to view the sales floor from the office, to systems that have over 1,000 cameras with multiple monitors and recording devices, such as a gaming establishment. Systems can monitor conditions both inside and outside the building.

The most important question that the designer must consider is “What is to be viewed?” Is the target to be the trans-

actions that occur at a point-of-sale or activity along an exterior fence line? Does the system need to make out a car’s license plate number or just the type of vehicle? The entire image recorded is the *field of view*, the focus of attention, such as a license plate, should be in the viewing area. For cameras placed to record images at a point of customer transactions, such as a teller window, the critical viewing area (face) should cover 15 percent of the camera’s field of view under normal resolution. Action within the scene should cover at least 20 percent or more of the overall width of the field of view. The designer should always consider the appearance of the final image when making camera and lens selections.

CCTV systems that are produced today for the majority of systems are charged-coupled device (CCD) units. Table D.4 summarizes the characteristics of CCD cameras.

CCD cameras come in a variety of imager formats, the most common being the following:

- (1) ¼ in.
- (2) ⅓ in.
- (3) ½ in.
- (4) ⅔ in.
- (5) 1 in.

The imager format is the usable part of the imager that is to be used. It is measured diagonally across the chip. The format of the chip will affect the view provided by the lens selected. The designer should look at both the camera format and the lens in order to make certain that the view selected is the view achieved.

D.4.1 Field of View. The field of view can be calculated by scene width as shown in Equation D.4.1a or by scene height as shown in Equation D.4.1b.

[D.4.1a]

$$f = c \left(\frac{d}{w} \right)$$

where:

- c* = width of the CCD chip
- d* = distance from camera
- w* = width of the field of view
- f* = focal length of camera lens

[D.4.1b]

$$f = v \left(\frac{d}{h} \right)$$

where:

- v* = height of CCD chip
- d* = distance from camera
- h* = height of field of view
- f* = focal length of camera lens

Another method takes into account the total critical viewing area as a percentage of the monitor. If the critical object takes up only a quarter of the total field of view within the monitor, then it would be 25 percent of the view. If the critical object took a third of the view it would be 33.3 percent of the view and so forth. (See Table D.4.1.)

Table D.2.3 Extents of Intrusion Detection Protection for Premises and Stockrooms

Extent of Protection	External Openings				External Surfaces	Special Considerations
	Accessible	Inaccessible	Movable Accessible	Movable Inaccessible	Walls, Floors and Ceilings	
4	Partial (2)					Contacts on at least two interior doors; or motion or sound detection on one or more selected areas; or one or more channels of radiation to limit movement within the premises.
Perimeter Motion (4) Sound 3 Channels	Complete		Partial (2,5) Partial (5) Partial (5)			Four-step (6) movement in each enclosed area with external openings. Sound detectors in each enclosed area with external openings. Limited to buildings with good acoustical qualities. Minimum length of beams equal to longest dimension of each enclosed area with external openings. Motion detectors can be used for channel protection.
Perimeter Motion Sound 2 Channels	Complete (3) Complete (3)		Partial (5) Partial (5)	Partial (5)	Complete (7)	Exterior surfaces of monolithic concrete do not require protection. Four-step (6) movement in each enclosed area with external openings. Sound detectors in each enclosed area with external openings. Limited to buildings with good acoustical qualities. Beams arranged to divide each enclosed area with external surfaces into at least three subdivisions. Maximum 1000 ft ² for each subdivision.
Perimeter 1 Sound or Vibration	Complete (3)	Complete (3)	Partial (5)	Partial (5)	Complete (7)	Protective wiring installed on all external surfaces. Detectors adjusted to initiate an alarm if a manhole size opening is created in an opening, ceiling, floor, or wall.

Notes:

- (1) Accessible means less than 18 ft for grade or adjacent roofs; less than 14 ft from horizontal openings; or less than 3 ft from openings on same wall.
- (2) Doors only.
- (3) Complete protection of an opening means wiring or other recognized means applied to protect the opening (fixed or movable) plus contacts on movable openings.
- (4) Motion detection is provided by equipment such as ultrasonic, microwave, and passive infrared motion detectors. It is installed throughout each area.
- (5) Partial protection means a contact installed on a movable opening.
- (6) Four-step movement is a means of confirming volumetric radiation coverage by performing a series of walk test through the enclosed area.
- (7) Complete protection of a surface means wiring or other recognized means to protect a wall, floor, or ceiling.

Source: Richard L. Sampson (Chairman), *A Practical Guide to Central Station Burglar Alarm Systems*, Central Station Alarm Association, Bethesda, MD, 1997, Table 4.

Used with permission from Underwriters Laboratories Inc.

Table D.3(a) Comparison of Reader/Card Technologies

Card Type	Technology	Durability	Resistance to Compromise	Re-Programming	Cost
Magnetic Stripe	Magnetic media stripe	M	M	Y	L
BaFe	Magnetic pattern	H	M	Y	L
Wiegand	Magnetic pattern	H	H	N	M
Bar Code	Light/dark patterns	L	L	N	L
Hollerith	Hole patterns	L	L	N	L
Proximity	Electromagnetic	H	H	N	M

Note:

L—Low, M—Medium, H—High, Y—Yes, N—No

Source: Gerard Honey, *Electronic Access Control*, Newnes, Oxford, UK, 2000, Table 3.2.

Table D.3(b) Hollerith

Advantages	Disadvantages
Low cost Can be changed quickly Simple technology	Low security Easily copied

Editor's Note: Limited to hotel guestroom access today, the Hollerith access control card is a card that has small holes that can be read by contact brushes or a light source. This card received its name from Herman Hollerith, inventor of the computer punch card.

Table D.3(c) Magnetic Stripe

Advantages	Disadvantages
Used for many applications Card can hold vast amounts of data Low cost Cards are easily manufactured and encoded Cards can carry alphanumeric data Insertion speed can vary	Wear out Cards can become chipped or break Unauthorized duplication

Editor's Note: The magnetic card reader is still a commonly used technology. The magnetic card is the most common method used at the time this Pocket Guide was published for banking and ATM use. A number of standards from the International Standards Organization (ISO) and American National Standards Institute (ANSI) cover the data formats found on these cards. Magnetic cards have a low coercivity, and thus could be damaged by a small magnet.

Table D.3(d) Barium Ferrite (BaFe)

Advantages	Disadvantages
Moderate cost Insertion speed can vary	Older technology Cards can break Unauthorized duplication

Editor's Note: The barium ferrite card is made up of a laminate of three-ply from two outer layers of PVC, which enclose a barium ferrite mixture that is capable of being magnetized. The BaFe card is encoded by passing the card through a strong magnetic field, which causes the barium ferrite beads within the card to be arranged to produce unique magnetic field patterns.

Table D.3(e) Radio Frequency Identification (RFID) Characteristics

Characteristic	Description
Basic RFID system	Consists of three parts: <ul style="list-style-type: none"> • Antenna or coil • Transceiver (with decoder) • Transponder (RF tag) electronically programmed with unique information
Categories of RFID systems	Grouped into four categories: <ul style="list-style-type: none"> • EAS (Electronic Article Surveillance) systems • Portable Data Capture systems • Networked systems • Positioning systems
RFID tokens (tags)	<ul style="list-style-type: none"> • Active (supplied with internal battery for power) • Passive (powered by field generated by reader)
Determination of range	Range that can achieved by a RFID system is determined by: <ul style="list-style-type: none"> • The power available at the reader to transmit to the tag • The power available within the tag to respond • The environmental conditions and structures in the area

Editor's Note: Radio Frequency Identification (RFID) is a wireless means of transmitting data from the reader to the card or tag. Like the magnetic stripe technology, access control is just one of the uses of RFID. If this technology is to be used, the designer needs to determine the range that the system must achieve. This will determine if a passive or active system is to be used.

Table D.3(f) RFID Frequency Band Characteristics

Frequency	Band Characteristics	Typical Applications
Low	Short to medium read range	Access control
100–500 kHz	Inexpensive Low reading speed	Animal identification Inventory control Car immobiliser
Intermediate	Short to medium read range	Access control
10–15 MHz	Potentially inexpensive Medium reading speed	Smart cards
High	Long read range	Railroad car monitoring
850–950 MHz	High reading speed	Toll collection systems
2.4–5.8 GHz	Line of sight required Expensive	

Source: *Draft Paper on the Characteristics of RFID-Systems*, The Association for Automatic Identification and Mobility, Warrendale, PA, 2000. Copyright © AIM, Inc. www.aimglobal.org; www.rfid.org

Calculate the viewing area of the scene and also the critical viewing area by multiplying the horizontal and vertical dimensions. Divide the critical view area in the monitor.

If the proportion of the critical viewing area is as expected, use the calculated focal length. If not, then change the focal length until the correct proportion is found. In some cases, the solution will be a new lens being selected.

D.4.2 Lenses. Lenses come in a number of formats. [See *Table D.4.2(a)*.]

The designer should use a field-of-view calculator to make the final determination. These calculators are available from most lens manufacturers. To select the proper lens for the format of the camera and the field of view, the designer should make an object distance calculation. [See *Figure D.4.2*.]

When calculating the target view of the camera, the object distance must be considered. In addition to the actual distance of the camera for the target, the height of the camera must be taken into consideration. The Pythagorean theorem is used in part to calculate the actual view distance. The square root of the number calculated is the object distance. Once the actual object distance is known, the designer can calculate the target size for a given format size. CCTV cameras use a 4:3 aspect ratio. As such, the vertical view will always be 75 percent of the horizontal view. [See *Table D.4.2(b)*.]

D.4.3 Depth of Field. Finally, when setting up an image to be viewed, lighting and depth of field must be considered. Depth of field is the region within the picture that will appear sharp in focus. *Table D.4.3(a)* summarizes the characteristics of depth of field.

The format of the lens will affect the depth of field. The amount of light will also affect the depth of field for a camera. In order to calculate the depth of field for an object that is not

close to the camera, Equation D.4.3a should be used. To calculate the depth of field for an object that is close to the camera, Equation D.4.3b should be used. To obtain the optimal view, in which the entire view would be in focus, Equation D.4.3c should be used.

$$ff = \frac{hd}{[h - (d - l)]} \quad \text{[D.4.3a]}$$

where:

ff = far focus limit (in mm)
 h = hyperfocal distance (in mm)
 d = lens focus distance (in mm)
 l = lens focal length

$$nf = \frac{hd}{[h + (d - l)]} \quad \text{[D.4.3b]}$$

where:

nf = near focus limit (in mm)
 h = hyperfocal distance (in mm)
 d = lens focus distance (in mm)
 l = lens focal length

$$h = \frac{ll}{fd} \quad \text{[D.4.3c]}$$

where:

h = hyperfocal distance (in mm)
 l = lens focal length
 f = lens aperture f-stop
 d = diameter of circle of least confusion (in mm)

The circle of least confusion is the area that is out of focus before and after the hyperfocal distance [See *Table D.4.3(b)*.] The circle is the area of the greatest light concentration behind the lens but in front of the imager of the camera.

D.4.4 Recording. The primary method of image storage is the digital video recorder (DVR). The number of images that can be stored on a single DVR is dependent on the size of the storage disk within the DVR, the image size, number of images per second, and quality. The following equation is used to determine the required hard drive size: (Image Size (KB) x (Images Per Second) x (Number of Cameras) x 0.0864 = Gigabytes (GB) Required Per Day.

The time-lapse mode will affect the amount of information captured. The designer, after a risk assessment, should take this into consideration when specifying the recording intervals to be used. [See *Table D.4.4(a)*.]

Real time is 30 images per second. A VCR in “real-time” mode records 20 images per second. [See *Table D.4.4(b)*.]

Over time and use, the video recording medium will wear down. The designer should specify the type of recording tape to be used and the replacement interval. Industrial grade recording tape should be used. [See *Table D.4.4(c)*.]

Table D.3(g) RFID Frequency Applications

Frequency Range	Applications and Comments
Less than 135 kHz	A wide range of products available to suit a range of applications, including animal tagging, access control, and track and traceability. Transponder systems which operate in this band do not need to be licensed in many countries.
1.95 MHz, 3.25 MHz, 4.75 MHz, and 8.2 MHz	Electronic article surveillance (EAS) systems used in retail stores
Approx. 13 MHz, 13.56 MHz	EAS systems and ISM (Industrial, Scientific and Medical)
Approx. 27 MHz	ISM applications
430–460 MHz	ISM applications specifically in Region 1
902–916 MHz	ISM applications specifically in Region 2. In the United States this band is well organized with many different types of applications with different levels of priorities. This includes railcar and toll road applications. The band has been divided into narrow band sources and wide band (spread spectrum type) sources. In Region 1 the same frequencies are used by the GSM telephone network.
918–926 MHz	RFID in Australia for transmitters with EIRP less than 1 watt
2350–2450 MHz	A recognized ISM band in most parts of the world. IEEE 802.11 recognizes this band as acceptable for RF communications and both spread spectrum and narrow band systems are in use.
5400–6800 MHz	This band is allocated for future use. The FCC has been requested to provide a spectrum allocation of 75 MHz in the 5.85–5.925 GHz band for Intelligent Transportation Services use. In France the TIS system is based on the proposed European pre-standard (preENV) for vehicle to roadside communications communicating with the roadside via microwave beacons operating at 5.8 GHz.

Source: *Draft Paper on the Characteristics of RFID-Systems*, The Association for Automatic Identification and Mobility, Warrendale, PA, 2000. Copyright © AIM, Inc. www.aimglobal.org; www.rfid.org

Table D.3(h) Proximity

Advantages	Disadvantages
No contact with reader required	Higher cost for card
Card is long lasting	Read effect of card can be affected by metallic objects located
High security	
Resistant to being compromised	
Reader can be concealed	

Editor's Note: The proximity card has an embedded circuit that transmits frequencies detectable by the reader. Proximity cards, key fobs, or tokens can be either passive or active. Active cards have a longer read distance, but have a finite life due to the internal battery.

Table D.3(i) Bar Code

Advantages	Disadvantages
Low cost	Low security
Easily produced	Easily duplicated
Can be used for “temporary” cards	
Cannot be corrupted by magnetic fields	

Editor’s Note: Bar codes come in a number of formats. They are standardized so that they may be used for a number of applications. Bar codes were first patented in 1952. Their first commercial application was for Point Of Sale checkout in grocery outlets. The Universal Grocery Products Identification Code (UGPIC) was the first standardized code. One of the most commonly used at the time this Pocket Guide was published was Code 39. Depending on the manufacturer of the bar code reader, systems may be able to decode a variety of bar code formats.

Table D.3(j) Wiegand

Advantages	Disadvantages
Moderate price	Encoded by manufacturer
High security	Older technology
Resistant to pocket damage	
Difficult to compromise	
Not affected by electromagnetic interference	

Table D.3(k) Hand/Finger Geometry

Advantages	Disadvantages
Type I and II error rates less than 1% are achievable	Systems designed for the right hand
Can function under extreme temperature ranges	Swelling or injury to hand can cause Type I errors
High user acceptance	

Table D.3(l) Fingerprints

Advantages	Disadvantages
Requires only one finger	Care must be taken in positioning the finger
Can be used for a number of applications	Dry and worn fingers can be difficult
Many systems now on the market	

Editor’s Note: Fingerprints have been used to identify humans for over 100 years. It is estimated that there are 10 to the 48th power of possible fingerprint patterns, making it very unlikely that two people will have the same fingerprint. This method of identification is becoming widely used for the securing of computers and workstations. Fingerprint readers may be optical, ultrasound, or direct imaging.

Table D.3(m) Handwriting

Advantages	Disadvantages
High user acceptance	Low security
Moderate Type I and Type II error rates	Time consuming
	Leans towards false acceptance

Table D.3(n) Eye Scan

Advantages	Disadvantages
Moderate Type I and Type II errors	Moderate to low user acceptance
High security	Time consuming
	PIN may be required for further verification

Editor’s Note: The pattern of blood vessels in the retina of the eye is unique. No two humans have the same pattern. Each iris is also unique, in its color and structure, and eye scan devices may include retina or iris. Eye scans are seen as being invasive, so while they provide a high level of security, user acceptance is mixed.

Table D.3(o) Recognition

Advantages	Disadvantages
High user acceptance	A person’s voice can change
Can be tied into telephone systems	PIN may be required for further verification
Less costly than other biometric methods	

Editor’s Note: Systems use a voice synthesizer to compare voice patterns, such as air pressure, voice pitch period, resonant frequencies of the vocal tract, and vibration caused by the movement of the larynx to that which was captured during enrollment.

Table D.3(p) Face Recognition

Advantages	Disadvantages
Systems can use CCTV	New technology*
Non contact	Wide variation in the presentation of the face
	Lighting
	Privacy issues

**At the time this Pocket Guide was published.*

Editor’s Note: This method is noninvasive and can be used at protected premises as a method to restrict access to a secure area. This technology is a concern of privacy rights groups when used in part with a CCTV system to scan people in public places, without their consent.

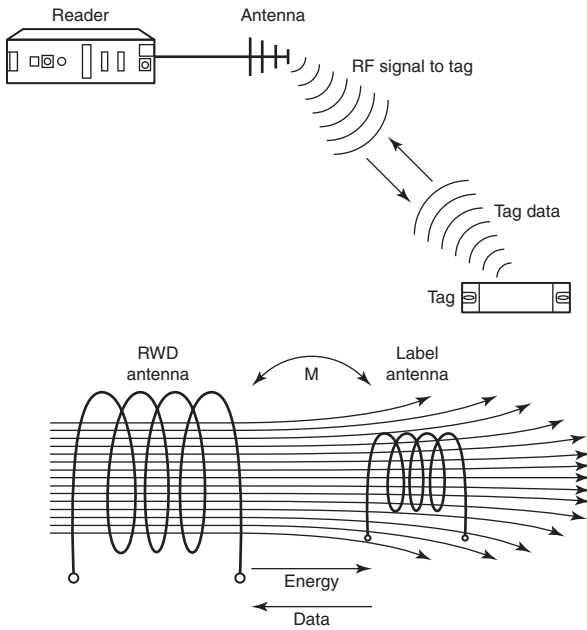

FIGURE D.3(a) Radio Frequency Identification (RFID) Diagrams.

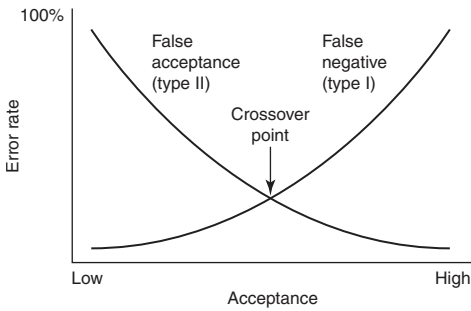

FIGURE D.3(b) Biometrics Error Rates.

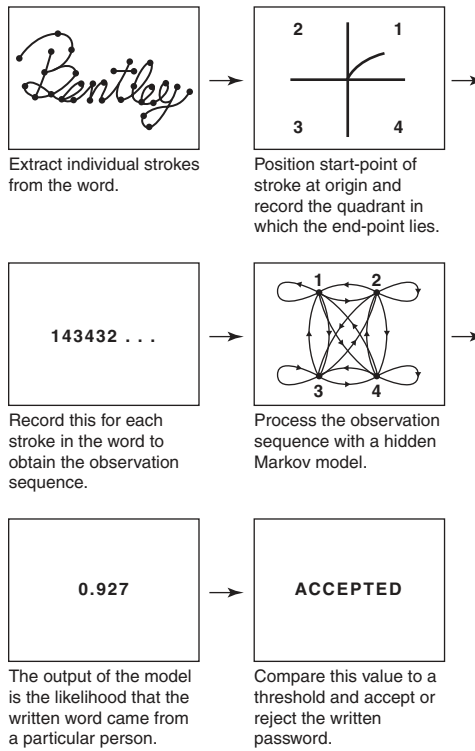

FIGURE D.3(c) Handwriting Diagram.

Table D.4 CCD (Charged-Coupled Device) Cameras

Camera Type	Light Type	IR Sensitivity	Resolution	Lag Time	Retain Image	Auto-Iris Lens	Expected Life
C-MOS/CCD	Full/Fairly Consistent 20–50 lx	Extreme High 1050–1300 nm average	Good/Fair-Inside-Fair/ Poor-Outside 300–400 TVL	None	None	Dependent On Application	3–5 Years Dependent On Conditions
Interline Transfer CCD	Low/Full Variable 3–5 lx	Extreme High 1050–1300 nm average	Very Good to Good 350 TVL & Up Average	None	None	Dependent On Application	3–5 Years Dependent On Conditions
Frame Transfer CCD	Low/full Variable 0.1–5 lx	Excellent 800–850 nm	Excellent to Very Good 400 TVL & Up	None	None	Dependent On Application	3–5 Years Dependent On Conditions
Hyper Had CCD	Note 1 1–50 lx	None	Very Good to Good 375 TVL & Up	None	None	Dependent On Application	3–5 Years Dependent On Conditions
Intensified CCD	Low/Full Variable .003 lx	None Visible Light Only	Good to Fair 275 to 400 TVL	Note 2	Chip- None Note 3	Always	1–2 Years Dependent On Conditions

Notes:

1—Due to design of chip, telephoto lenses will produce a sharper image.

2—The method of light amplification that is used will determine the amount of lag time in lower light conditions.

3—It is possible to burn an image into the 2nd generation intensifier that may be used in these cameras.

Source: Charlie Pierce, Application & Design of CCTV, LeapFrog Training & Consulting, Davenport, IA, 2002, p. 28.

Editor's Note: The CCD camera is the most popular CCTV camera in use at this time. They are entirely solid state.

Table D.4.1 Field of View

Camera Formats (in.)	Horizontal (mm)	Vertical (mm)
1/4	3.2	2.4
1/3	4.4	3.3
1/2	6.4	4.8
2/3	8.8	6.6

Table D.4.2(a) Lens Formats

Focal Length	Lens	Range
4 mm	Very Wide Angle	4–6 ft
8 mm	Wide Angle	12 ft
16 mm	Standard	25 ft
25 mm	Telephoto	45 ft
50 mm	Long Telephoto	50–60 ft

Editor's Note: This chart is based on a CCD camera. The designer and installer should use a field of view calculator to make a final determination. These calculators are available from most lens manufacturers.

Table D.4.2(b) Formats

Camera Format Size	¼ in.	⅓ in.	½ in.	⅔ in.	1 in.
Diagonal Format	4 mm	5.5 mm	8 mm	11 mm	16 mm
Horizontal Format	3.6 mm	4.8 mm	6.4 mm	8.8 mm	12.8 mm
Vertical Format	2.7 mm	3.6 mm	4.8 mm	6.6 mm	9.6 mm

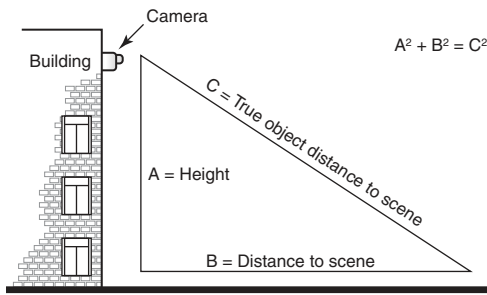

FIGURE D.4.2 Object Distance Calculations.

Table D.4.3(a) Depth of Field

Broad Depth of Field	Narrow Depth of Field
Wider Angle of Lens More Light	More Telephoto Less Light

Editor's Note: This is the region within the picture that will appear sharp or in focus. The format of the lens will affect the depth of field. The amount of available light will also affect the depth of field for a camera.

Table D.4.3(b) Circle of Least Confusion

Format	Circle of Least Confusion
¼ in.	0.00019 mm
⅓ in.	0.00013 mm
½ in.	0.00009 mm
⅔ in.	0.00007 mm
1 in.	0.00005 mm

Editor's Note: The circle(s) of confusion is the area that is out of focus before and after the hyperfocal distance. The circle of least confusion is the area of greatest light concentration behind the lens but in front of the imager of the camera.

Table D.4.4(a) Time Lapse Recording Intervals

Time Lapse Mode	Images Per Second	Time Between Images in Seconds
12 hr	10	0.1
24 hr	5	0.2
72 hr	1.6	0.6
168 hr	0.7	1.4
240 hr	0.5	2
480 hr	0.25	4
960 hr	0.125	8

Source: Bryan McLane and Charles Aulner, *CCTV Systems, Design & Installation*, National Training Center, Inc., Las Vegas, NV, 2004, p. 89.

Editor's Note: The time lapse mode use will affect the amount of information captured. The designer, after a risk assessment, needs to take this into consideration when specifying the recording intervals to be used.

Table D.4.4(b) Multiplex/VCR Record Rate

Time Lapse Mode	4 Cameras	8 Cameras	16 Cameras
24 hr "Real Time"	0.2	0.4	0.8
24 hr	0.8	1.6	3.2
72 hr	2.4	4.8	9.6
168 hr	5.6	12.8	22.4
240 hr	8	16	32
480 hr	16	32	64
960 hr	32	64	128

Source: Bryan McLane and Charles Aulner, *CCTV Systems, Design & Installation*, National Training Center, Inc., Las Vegas, NV, 2004, p. 92.

Editor's Note: Real time is 30 images per second. A VCR in "Real Time" mode records 20 images per second. Exhibit V.36 shows the time in seconds that is required to record all of the cameras that may be connected to a system, and being recorded by a single recorder.

Table D.4.4(c) Tape Rotation Interval

Time Lapse Mode	Number of Uses
2–120 hr	30
121–240 hr	15
241–400 hr	10
401–960 hr	5

Source: Bryan McLane and Charles Aulner, *CCTV Systems, Design & Installation*, National Training Center, Inc., Las Vegas, NV, 2004, p. 96.

Editor's Note: Over time and use, the video recording medium will wear down. The designer should specify the type of recording tape to be used and the replacement interval. Industrial grade medium should be used.

Annex E Resources for Protection of Cultural Resource Property Projects

This annex is not a part of the requirements of this NFPA document but is included for informational purposes only.

E.1 Introduction. A fire protection consultant can be a valuable resource in evaluating the current status of fire safety for a cultural property and in recommending creative solutions to improve fire safety and achieve fire safety goals. To realize maximum benefit from engaging a fire protection consultant, the consultant's qualifications and the client's needs should be properly matched. The consultant should have qualifications equivalent to professional member grade in the Society of Fire Protection Engineers (SFPE).

The consultant's experience should be evaluated, both as a company and as individual consultant team members, in providing fire protection consulting services to cultural resource properties. One should also compare the consultant's experience with the nature of the work to be performed and the size of the project being considered. As a final evaluation factor for experience, one should consider whether the specific team proposed has worked together and the degree to which the experience is team experience.

Other factors that should be used in evaluating a consultant's qualifications are membership and participation in organizations such as NFPA, the American Institute of Architects (AIA) for registered architects, the National Society of Professional Engineers for registered engineers, and the model building code organizations. Participation on committees of these organizations is a further measure of the consultant's understanding of fire safety issues in cultural resource properties.

Fire protection systems should be designed by a licensed professional engineer authorized to practice within the jurisdiction where the work is performed. In the United States, each state normally requires licensure as a professional engineer.

After information has been collected on the fire protection consultant's qualifications, references should be contacted to determine how the consultant has actually performed on similar projects.

E.2 NFPA. National Fire Protection Association, 1 Batterymarch Park, Quincy, MA 02169-7471.

NFPA publishes this and related documents on fire protection, and answers inquiries on these documents. NFPA also conducts educational seminars, studies, and literature searches for a fee.

NFPA publishes a directory of fire protection consultants in the Fire, Electrical, and Building Safety Resource, available on the NFPA website at www.nfpa.org.

E.3 SFPE. Society of Fire Protection Engineers, 7315 Wisconsin Avenue, Suite 620E, Bethesda, MD 20814.

SFPE is a professional society of fire protection engineers. They meet annually, publish technical information, conduct technical seminars, and support local chapters. Members are located in all parts of the world. Names and addresses of members in a particular geographic area can be obtained from SFPE headquarters.

E.4 NICET. National Institute for Certification in Engineering Technologies, 1420 King Street, Alexandria, VA 22314.

NICET certifies technicians in the following areas: automatic sprinkler system layout, fire alarm systems, inspection and testing of water-based systems, special hazards suppression systems (e.g., automatic and manual foam water, halon, carbon dioxide, and dry chemical systems), suppression video security systems design, and video security systems technician. People with a NICET certification can also assist in the selection and use of protection systems. NICET provides certification for four levels of competence in all four of the listed areas of fire protection.

E.5 UL. Underwriters Laboratories, 333 Pfingsten Road, Northbrook, IL 60062.

UL has a certification service through which alarm companies can be qualified to issue certificates that installed fire warning systems comply with NFPA standards and are properly tested and maintained. A list of alarm service companies authorized to issue UL certificates is available. UL also publishes safety standards and annual directories of labeled and listed products and fire-resistant assemblies.

Annex F Sample Ordinance Adopting NFPA 909

This annex is not a part of the requirements of this NFPA document but is included for informational purposes only.

F.1 The following sample ordinance is provided to assist a jurisdiction in the adoption of this code and is not part of this code.

ORDINANCE NO. _____

An ordinance of the [jurisdiction] adopting the [year] edition of NFPA [document number], [complete document title], and documents listed in Chapter 2 of that [code, standard]; prescribing regulations governing conditions hazardous to life and property from fire or explosion; providing for the issuance of permits and collection of fees; repealing Ordinance No. _____ of the [jurisdiction] and all other ordinances and parts of ordinances in conflict therewith; providing a penalty; providing a severability clause; and providing for publication; and providing an effective date.

BE IT ORDAINED BY THE [governing body] OF THE [jurisdiction]:

SECTION 1 That the [complete document title] and documents adopted by Chapter 2, three (3) copies of which are on file and are open to inspection by the public in the office of the [jurisdiction's keeper of records] of the [jurisdiction], are hereby adopted and incorporated into this ordinance as fully as if set out at length herein, and from the date on which this ordinance shall take effect, the provisions thereof shall be controlling within the limits of the [jurisdiction]. The same are hereby adopted as the [code, standard] of the [jurisdiction] for the purpose of prescribing regulations governing conditions hazardous to life and property from fire or explosion and providing for issuance of permits and collection of fees.

SECTION 2 Any person who shall violate any provision of this code or standard hereby adopted or fail to comply therewith; or who shall violate or fail to comply with any order made thereunder; or who shall build in violation of any detailed statement of specifications or plans submitted and approved thereunder; or fail to operate in accordance with any certificate or permit issued thereunder; and from which no appeal has been taken; or who shall fail to comply with such an order as affirmed or modified by a court of competent jurisdiction, within the time fixed herein, shall severally for each and every such violation and noncompliance, respectively, be guilty of a misdemeanor, punishable by a fine of not less than \$ _____ nor more than \$ _____ or by imprisonment for not less than _____ days nor more than _____ days or by both such fine and imprisonment. The imposition of one penalty for any violation shall not excuse the violation or permit it to continue; and all such persons shall be required to correct or remedy such violations or defects within a reasonable time; and when not otherwise specified the application of the above penalty shall not be held to prevent the enforced removal of prohibited conditions. Each day that prohibited conditions are maintained shall constitute a separate offense.

SECTION 3 Additions, insertions, and changes — that the [year] edition of NFPA [document number], [complete document title] is amended and changed in the following respects:

List Amendments

SECTION 4 That ordinance No. _____ of [jurisdiction] entitled [fill in the title of the ordinance or ordinances in effect at the present time] and all other ordinances or parts of ordinances in conflict herewith are hereby repealed.

SECTION 5 That if any section, subsection, sentence, clause, or phrase of this ordinance is, for any reason, held to be invalid or unconstitutional, such decision shall not affect the validity or constitutionality of the remaining portions of this ordinance. The [governing body] hereby declares that it would have passed this ordinance, and each section, subsection, clause, or phrase hereof, irrespective of the fact that any one or more sections, subsections, sentences, clauses, and phrases be declared unconstitutional.

SECTION 6 That the [jurisdiction's keeper of records] is hereby ordered and directed to cause this ordinance to be published.

[NOTE: An additional provision may be required to direct the number of times the ordinance is to be published and to specify that it is to be in a newspaper in general circulation. Posting may also be required.]

SECTION 7 That this ordinance and the rules, regulations, provisions, requirements, orders, and matters established and adopted hereby shall take effect and be in full force and effect [time period] from and after the date of its final passage and adoption.

Annex G Compact Storage Fire Tests

This annex is not a part of the requirements of this NFPA document but is included for informational purposes only.

G.1 Introduction. The test reports and summary included in this annex provide fire size, site-specific information, storage configurations, and automatic fire suppression systems design information.

The following features were found to have a significant impact on this type of hazard:

- (1) Fuel type and arrangement; for instance, a slow fire was observed in the 1979 tests in densely packed archive storage boxes (ordinary hazard sprinkler system design), and a fast fire growth was observed in the 1992 tests with loosely stored newspaper and corrugated cartons (extra hazard sprinkler system design)
- (2) Configuration of storage including a gap between storage units
- (3) Storage height
- (4) Overhead clearance above storage
- (5) Room height
- (6) Open shelving versus closed shelving
- (7) Sprinkler density and sprinkler response time

The following article, “Full-Scale Fire Tests and the Development of Design Criteria for Sprinkler Protection of Mobile Shelving Units,” is from *Fire Technology*, Volume 30, No. 1 (1994).

Full-Scale Fire Tests and the Development of Design Criteria for Sprinkler Protection of Mobile Shelving Units

G. D. Lougheed, J. R. Mawhinney, and J. O'Neill

Lougheed and Mawhinney are with the National Research Council Canada in Ottawa, Canada. O'Neill is with Gage-Babcock and Associates, Inc., in Vienna, Virginia.

Abstract

In early 1991, a new sprinkler system was planned for the existing National Archives/National Library of Canada building in Ottawa. A major challenge in the design and installation of the sprinkler systems was to protect mobile compact shelving units located in the three levels below grade. Storage of documents in these shelving units is typically within 178 mm of the concrete slab ceiling. The minimum clearance permitted by the sprinkler system installation standard is 457 mm from the sprinkler deflector to the top of the storage. To conform with the sprinkler design standard, the top level or levels of storage would have had to be removed and additional storage space acquired. Because of the annual cost of this additional storage, an investigation was begun to determine feasible alternatives that would permit a reduction in clearances between sprinklers and storage, while maintaining an acceptable level of fire safety. This paper describes the series of five full-scale fire tests that were conducted to assess various fire protection options. Based on these tests, design criteria were developed for a sprinkler system using quick response horizontal sidewall sprinklers to protect the mobile shelving units. An overview of this technically based fire protection system for use in protecting shelving units with reduced clearance is also presented.

Introduction

In early 1991, a new sprinkler system was planned for the existing National Archives/National Library of Canada building in Ottawa. A major challenge in the design and installation of the sprinkler systems was to protect mobile compact shelving units located in the three levels below grade in the building. Storage of documents in these shelving units is typically within 178 mm of the concrete slab ceiling. Since the minimum clearance permitted by the sprinkler system installation standard [1] is 457 mm from the sprinkler to the top of the storage, the potential impact on existing storage practices and space

requirements for the National Archives/Library was significant. In order to comply with the sprinkler installation standard and to ensure adequate fire protection, the library faced the prospect of removing all storage from the top shelves and, in many cases, the top two shelving rows throughout the stacks. In addition to the library staff that would be needed to remove and reorganize files, there would also be considerable annual costs for additional storage space.

Because of the tremendous cost involved in fully protecting the building in accordance with the standard, Public Works Canada and the National Library of Canada began an investigation to determine feasible alternatives that would permit a reduction in clearances between the sprinklers and the storage, while maintaining an acceptable level of fire safety. The question was whether a sprinkler system could extinguish or control a fire in the shelving units, taking into consideration the specific geometry and nature of the fuel package.

Based on discussions with the Fire Commissioner of Canada, who was the authority having jurisdiction, it was determined that technically based alternatives to strict compliance with the applicable installation standard would be considered. However, any alternative arrangements would have to be evaluated on the basis of full-scale fire tests, which would demonstrate that the proposed sprinkler installation could extinguish or control a fire at least as well as an installation that conformed to the installation standard. This approach, based on equivalents, is allowed within the terms of the *National Building Code of Canada*. [2]

This paper describes the five full-scale fire tests that were conducted at the National Fire Laboratory's full-scale test facility near Almonte, Ontario. These tests were used to assess various sprinkler system options for protecting the compact shelving units. Based on the results of these tests, design criteria were developed for a fire protection system to be used in the basement levels of the library. This fire protection system would result in a minimal loss of effective storage space and was recommended to Public Works Canada as a technically based alternative.

Previous Work

Before the tests discussed in this paper were undertaken, two series of fire tests on compact mobile shelving units were conducted. The first series, conducted at Factory Mutual Research Corporation in 1978,[3] indicated that, with the available state-of-the-art sprinkler technology, the records stored in the shelving were substantially damaged by the fire despite "successful" sprinkler operation.

The second series of fire tests was conducted at Underwriters Laboratories Inc. in 1989 to develop the sprinkler protection system for a new U.S. Archives building in Washington, D.C. (Archives II). These tests showed that quick response sprinklers, along with enhancements in the operation and construction of the mobile shelving units, could limit fire damage to the archival records located near the ignition source. [4]

The sprinkler system developed for Archives II was intended for use in a new facility designed to meet current codes and standards. As such, it was possible to specify the requirements for both the sprinkler system and the shelving units to provide an optimum fire protection system. The sprinkler system developed as part of this current study was intended for retrofit in an existing facility in which a sprinkler system could not be

installed to meet installation standards without a substantial loss of storage capacity.

Description of Hazard

The mobile stack units present in the basement levels of the National Library were "Compactur" mobile shelving units.† (See footnote at the end of extract.) These were entirely open units; that is, the shelves had no tops, and there were no internal partitions. The shelving units were typically 4.6 m long. Fixed shelves were spaced approximately 6.1 m on center, with five to seven mobile shelves between them [see Figure G.1(a)].

The basic stack units were arranged to provide access aisles 1.2 m wide at the ends of the shelves. There was minimal clearance between the shelving units of stack arrays adjacent to walls and the walls themselves. Access to these stack arrays was from one end only.

Each mobile shelving unit consisted of a mobile carriage mounted on rails [see Figure G.1(b)]. Six upright columns equispaced along the center line of the carriage were used to support cantilever shelves mounted on both sides. Typically, there were six levels of shelving mounted on each unit, for a total of 60 shelving sections per unit.

The contents of the shelves were predominantly paper documents, such as letters, reports, memos, and journals, stored in corrugated cardboard document boxes with closed lids. There were a number of plastic plan canisters in the building, but these were confined to a limited area and were not considered to represent a typical fuel load. There was no storage of microfiche, film, or cassettes.

The cardboard document boxes, which were 210 mm wide by 387 mm long and 254 mm high [see Figure G.1(b)], were packed side-by-side with four boxes on each shelf section and up to 240 boxes on each mobile unit. For the most part, they were partially filled with an average weight of 6.8 kg, including the box. The total fuel load on each mobile unit was thus approximately 1,650 kg. For a typical shelving area consisting of two fixed shelves and five mobile shelves, the fuel load density was approximately 375 kg/m² averaged over the shelving area.

In localized areas, there was also extensive storage of folded newspapers in open-topped, cloth-covered periodical boxes 102 mm wide by 228 mm long and 298 mm high. The average weight of each periodical box was 2.3 kg. When the shelves were closed, the boxes on adjacent mobile shelves were grouped so tightly that sprinkler spray could not penetrate below the top level. This was not the case where the mobile shelves faced fixed shelves, however. Rubber stops, which were placed at the ends of the rails to keep the mobile units from running off the tracks, also maintained a minimum clearance of 102 mm between the material stored on the fixed shelves and the first adjacent mobile shelf. The newspapers were packed tightly together in the periodical boxes. When the shelves were closed, the ends of the newspaper touched such that sprinkler spray could not penetrate below the top level.

The Test Facility

A full-scale mock-up of a shelving array typical of those found in the basement of the National Library was constructed at the National Fire Laboratory's full-scale test facility. The National Library of Canada provided typical shelving units that consisted of two fixed shelves and five double-row mobile units.

The stack array covered an area approximately 4.6 m by 6.7 m. The test facility is shown in Figure G.1(c) and Figure G.1(d). As a basis for instrumentation and recording observations, each shelving section was labeled using an alphanumeric system. For this system, each side of a shelving unit was assumed to be a single row of shelves and was labeled alphabetically. The numbering system for Row H is illustrated in Figure G.1(c).

Four wall assemblies, constructed using wood studs and gypsum wallboard with approximately 25% of the wall area left uncovered, were positioned around the shelving bay to simulate adjacent shelving units. This partially closed perimeter was intended to replicate obstructions, such as adjacent columns and other stack units, that could affect air movement in the building. Two walls 4.6 m long were positioned 0.75 m from the fixed shelving unit to simulate mobile shelves in adjacent shelving bays. Two wall sections 8.2 m long were located 1.2 m from the sides of the shelving unit to simulate the normal access aisles and adjacent shelving bays.

The test facility was covered with a noncombustible ceiling assembly. The ceiling in the shelving area and above one corridor was 2.4 m high. In the other corridor, the ceiling height was reduced to 2.2 m to simulate the ventilation ducts that are located in every second corridor in the library and that are as wide as the aisle. There was minimal clearance (25 to 50 mm) between the sides of these ducts and the shelving units. The ducts act as barriers to the flow of hot gases and sprinkler spray; as such, they have a considerable impact on both the location and activation of the sprinklers.

A series of 600 mm square structure columns, with column caps 1.83 m square by 125 mm deep, were located throughout the basement, as shown in Figure G.1(a). These columns, which are located at the end of the fixed shelving units, did not have an impact on the fire scenario used in the test program and were not simulated in the test facility. Because of the very limited clearances above the storage and the depth of the column caps, these columns limited the arrangement of sprinkler piping in the library and had to be taken into account when the sprinkler system design criteria were developed.

Fire Scenario

Based on an assessment of the hazard as a result of the observations in the library, an initial worst-case fire scenario was developed for the full-scale fire tests:

- (1) All the mobile units would be pushed tightly together with minimal or no space between the storage on adjacent shelves.
- (2) The fire would start at the bottom center of the closed mobile units at the maximum distance from the nearest sprinklers. Such a fire could involve the maximum fuel before sprinkler activation. It would also be in the area to which there would be the least amount of sprinkler penetration.
- (3) The shelving units and the fuel load would be typical of that observed in the library.
- (4) A fuel load combination consisting of the open newspaper storage on the mobile units adjacent to the fire source and document boxes on the remaining shelves was thought to present the maximum challenge to the sprinkler system. In developing this scenario, it was assumed that the exposed edges of the newspaper would result in a very rapid initial fire spread. This rapidly developing fire could burrow into areas with high fuel load densities (the document boxes), thus posing the possibility of a sustained, high-severity fire.
- (5) The clearance between the ceiling and the top level of storage on the shelves would be 178 mm + 25 mm.

Despite the fact that there were areas in the library where there were clearances of only 102 mm, the 178 mm clearance for the initial tests was chosen for two reasons. First, Public Works Canada and the National Library of Canada asked that on-off sprinklers be used for the first sprinkler system tested, and such sprinklers are quite large in comparison to conventional pendent sprinklers. Assuming commercially available copper fittings and the copper tubing installed as close to the concrete ceiling as possible, along with the dimensions of the specified sprinkler, it was estimated that the sprinkler deflector would be a minimum of 133 mm below the ceiling in the closed position. When activated, the deflector extended 18 mm further. The specified clearance of 178 mm thus provided a minimum 25 mm clearance between the sprinkler deflector and the top of the storage. Second, the library would have had to remove the top level of shelves to provide a clearance greater than 178 mm.

Thus, the specified clearance of 178 mm would provide at least a minimum clear space for the development of the sprinkler spray without reducing the storage capacity in the library.

Sprinkler Layouts

The first sprinkler arrangement used pendent sprinklers to protect the stack area [see Figure G.1(d)]. In developing the pendent sprinkler layout, it was assumed that the combination of the following factors would make it very difficult to get effective sprinkler coverage for all areas:

- (1) The minimal clearance between the sprinkler deflector and the material on the top shelves, and
- (2) The presence of obstructions such as light fixtures and column caps in the library stack areas.

In an attempt to improve the sprinkler coverage in the confined space between ceiling and storage, the sprinklers were spaced much closer together than would normally be the case for an NFPA 13 sprinkler system [see Figure G.1(d)]. Each sprinkler covered an area of less than 4.5 m²; normally, they would be permitted to cover up to at least 12 m² for this occupancy.

The on-off sprinklers were installed with the deflector 133 mm below the ceiling in the closed position. In the operating position, the deflector was 151 mm below the ceiling, providing a clearance of 27 mm between the sprinkler and the top of the storage. The quick response sprinklers were installed with the deflector 125 mm below the ceiling. This provided an additional 26 mm clearance between the top of the storage and the sprinkler.

The second sprinkler arrangement used horizontal sidewall sprinklers (HSW) to protect the stack array [see Figure G.1(e)]. Even though NFPA 13 does not recognize the use of horizontal sidewall sprinklers in this configuration, it was anticipated that HSW sprinklers would be able to provide a uniform spray distribution in the 178 mm clear space. The layout for the horizontal sprinklers was designed to maximize water spray coverage and minimize the possibility of spray from one sprinkler delaying the activation of adjacent sprinklers. To achieve this, the sprinklers were arranged in a staggered array on opposite sides

of the shelving units. On the side of the stack array with three sprinklers, the two end sprinklers were centered on the gap between the fixed shelving unit and the first mobile unit. This ensured maximum water spray penetration into the one area where, because of the stops installed on the rails, relatively “good” penetration of water spray to the lower shelving levels was possible. The third sprinkler on that side was located on the center of the shelving array, giving a 2.6 m spacing between the sprinklers. The two sprinklers on the opposite side of the stack array were staggered so as to be exactly half way between the sprinklers on the opposite side.

For the initial tests with horizontal sidewall sprinklers, the sprinklers were installed with the deflectors a nominal 100 mm \pm 12 mm below the ceiling. This is in accordance with the standard for the installation of sidewall sprinklers. [1] The distance between the ceiling and the top of the storage was 178 mm.

The fifth test investigated the possibility of providing sprinkler coverage over a stack array with only 100 mm clearance instead of 178 mm. In this test, the HSW sprinklers were positioned closer to the ceiling, with a nominal 50 mm clearance between the ceiling and the sprinkler deflector. It was thought that this arrangement could be achieved with commercially available fittings, and it ensured that the sprinkler deflector was at least 25 mm above the top level of storage.

In order to maximize spray coverage, the horizontal sprinklers were positioned with the deflectors as close as possible to the end of the shelving array. For the end with the HSW sprinkler against the aisle duct (soffit ceiling), it was assumed that, using commercially available hardware, the sprinkler would protrude 150 mm to 200 mm into the shelving array.

For both sprinkler layouts — that is, those using either pendent or HSW sprinklers — six pendent sprinklers were used in the aisles. These sprinklers were located at the centers of the fixed shelves and at the center of the stack array, giving a nominal spacing of 3.05 m along the length of the aisle. For the aisle with the higher ceiling, the three sprinklers were positioned on the center line of the aisle. In the second aisle, where the duct reduced the headroom, it was assumed that the sprinklers would be positioned near one side of the aisle for safety purposes. For the purpose of this test program, a worst-case scenario with the sprinklers positioned along the side of the corridor opposite the test array was selected. The pendent sprinklers under the duct were installed with the deflector 133 mm below the duct for the on-off sprinklers and 125 mm below the duct for the quick response sprinklers.

The sprinkler system was connected to the laboratory’s 2,080 L/min fire pump with a maximum static pressure of 895 kPa. Provisions were made to control and measure the pressure and water flow rate at the base of the 50 mm diameter riser used to feed the test facility’s sprinkler system. A series of flow measurement tests was carried out to map the water supply/demand curves for the system. These tests indicated that, for the five to seven sprinklers that typically activated during these tests, maximum flow rates of 870 to 1,040 L/min at pressures of 669 to 552 kPa could be supplied to the sprinkler system.

The specifications for the sprinklers used in all tests are given in Table G.1(a). The two quick response glass-bulb-type sprinklers were from the same manufacturer.

Table G.1(a) Sprinkler Specifications

Sprinkler	Activation Mechanism	Temperature Rating (°C)	Orifice (mm)	K-factor [L/min/(bar) ^{1/2}]
On/off pendent	Fusible alloy	60	12.5	80
	Bimetallic disk	74		
QR pendent	Glass bulb	68	12.5	80
QR horizontal sidewall	Glass bulb	68	12.5	80

Spray Distribution Tests

Preliminary spray distribution tests were conducted with the three types of sprinklers used for the full-scale tests. These tests concentrated on the sprinklers’ ability to wet the top level of storage on the shelving array. The assessments were qualitative in nature, with the primary criterion being the ability of the sprinklers to wet the corrugated document boxes placed on the top level of shelving. No effort was made to determine the actual water spray distribution. However, these tests did play an important role in determining the sprinkler flow rates used for the full-scale tests.

On-Off Pendent Sprinklers

The spray distribution test was conducted with three of the four sprinklers closest to the fire source. The sprinklers were mechanically “opened,” and the flow was initially set at an average of 58 L/min each. At a “K” factor of 80 L/min/(bar)^{1/2}, the pressure at each sprinkler was approximately 50 kPa, which is the minimum pressure necessary to operate according to product listing/approval standards and NFPA 13. The average density at this flow rate was 12.2 (L/min)/m². This is higher than the minimum required by NFPA 13 but is consistent with the densities used to protect similar stack systems in the Archives II test series. The test at this flow rate indicated that substantial portions of the upper level of the storage would receive minimal or no water spray.

In a second test, the average flow rate per sprinkler was increased to 84.4 L/min, and the pressure was increased to 108 kPa. With the given spacing, this flow rate resulted in a density of 18.7 (L/min)/m², which is greater than the density NFPA 13 requires for facilities classified as “Extra Hazard.” Although some improvement in the wetting pattern was observed, an unwetted area remained at the center of the sprinkler array.

With the limited clearance between the deflector of the on-off pendent sprinkler and the top of the storage and with the predominantly downward direction of the spray, most of the spray hit the boxes very close to the sprinkler. Wetting at the center of the sprinkler array was primarily due to splashing from the top of the boxes.

Based on the water spray tests, it was concluded that control probably would not be achieved using the lower flow rate. With the minimum spacing between the sprinkler deflector and the storage, it was also felt that any further increase in the flow rate would not result in a significant improvement in the spray pattern. As a result, the 84.4 L/min flow rate per sprinkler was chosen for the full-scale test.

Quick Response Pendent Sprinklers

Spray distribution tests were also conducted with the quick response (QR) pendent sprinklers. Three flow rates providing densities of 12.6 (L/min)/m², 15.8 (L/min)/m², and 18.7 (L/min)/m² were used. The results of these tests indicated that the added clearance provided by the low-profile sprinklers allowed for more effective wetting across the top of the storage than was achieved with the on-off sprinklers. However, wetting at the center of the array was only achieved with the higher flow rates. For Test 2, in which the QR pendent sprinklers were used, a density of 18.7 (L/min)/m² was selected.

Quick Response Horizontal Sidewall Sprinklers

Spray distribution tests were carried out using only the three horizontal sidewall sprinklers closest to the fire source. Flow rates providing densities of 14.3 (L/min)/m² and 16.0 (L/min)/m² were assessed. The horizontal sprinklers were able to provide uniform wetting over the entire shelf area at both pressures.

Sprinkler Response Times

Before the full-scale tests were conducted, the activation times for the pendent and horizontal sprinklers were estimated using the sprinkler/detector response model in FPETOOL. [5] For the fire scenarios used in the full-scale tests, the nearest pendent and sidewall sprinklers were 1.5 m and 2.5 m from the center line of the plume, respectively. An RTI of 28 (ms)^{1/2} was assumed for both sprinklers.

For the sprinkler/detector response routine, the fire growth rate and the height of the ceiling above the fire must be input. With the limited flammability data available for the fuel package involved in the test, it was impossible to model the initial fire development. The four standard fire growth models — slow, medium, fast, and ultra-fast growth rates [5] — included with FPETOOL were used to compare the activation times for the pendent and horizontal sidewall sprinklers.

During preliminary tests with the fuel package in the test array, it was observed that, once it began, the fire spread rapidly upward on the material stored on the shelves above the fire source. Thus, there was fire at all levels of the shelving between the floor and the ceiling very early in the test. For these simulations, it was assumed that the base of the fire was located 1.5 m below the ceiling.

The results for the four simulations using FPETOOL are shown in Table G.1(b). These calculations were conducted using the 68°C quick response glass bulb sprinklers. Based on these results, it was estimated that the sidewall sprinklers would require 25% more time to activate than the pendent sprinklers. Since it was assumed that early sprinkler activation could be a crucial factor in controlling the fire, it was decided that the pendent sprinkler arrangement should be tested, even though it provided a very poor water spray distribution.

Table G.1(b) Sprinkler Activation Times for 68°C Quick Response Glass Bulb Sprinklers

Distance from Fire Source (m)	Minimum Fire for Activation (kW)	Activation Time Medium Fire (sec)	Activation Time Fast Fire (sec)	Activation Time Ultra-Fast Fire (sec)	Sprinkler Activation Fire Tests (sec)
1.5	67	106	62	36	50–60
2.5	112	134	78	46	70–90

The results of the FPETOOL simulations were later confirmed by the full-scale tests. The temperatures measured at the sprinklers during the first 60 to 90 seconds of the full-scale tests were comparable to those calculated using the “fast” fire growth rate. The observed activation times for the sprinklers closest to the fire were comparable to those estimated by the computer model. That is, the pendent and sidewall sprinklers nearest the fire plume were typically activated within 50 to 60 seconds and 70 to 90 seconds, respectively, during the full-scale tests.

In addition to using FPETOOL to predict sprinkler response times, preliminary fire tests were conducted to assess the response times of the sprinklers. A propane gas burner, capable of generating 95 kW, was positioned in the same location as the ignition source for the full-scale tests. For these activation tests, sprinklers were mounted in the four pendent and three sidewall locations closest to the fire source. The horizontal sidewall sprinklers were located 1 m further from the fire source than the pendent sprinklers. The 95 kW heat release rate provided by the propane burner was lower than the minimum required to bring about early activation of the sidewall sprinklers. The sidewall sprinklers mounted in the open, below the smooth ceiling, required considerably more time to activate than the pendent sprinklers. However, it was noted that the sidewall sprinklers which were mounted against the duct at the low ceiling side of the test facility activated approximately 50% earlier than the sprinklers mounted in the open on the opposite side of the stack unit. It was decided, therefore, to mount a sheet metal baffle 152 mm deep behind the horizontal sprinklers located on the side of the shelving unit with the smooth ceiling. This baffle was intended to provide the same effect as the soffit created by the duct. The baffles also minimized the possibility that back spray from the sidewall sprinklers would affect the aisle sprinklers.

Full-Scale Tests

It should be emphasized that this was an engineering study directed at developing a sprinkler system that would provide protection equivalent to that intended by compliance with standards. This paper will not give detailed results for each of the five full-scale tests conducted. Instead, it will emphasize those results and observations that illustrate the sprinkler system’s ability — or, in some cases, inability — to control or extinguish the fire.

For all full-scale tests, ignition was provided by 500 mL of 95% ethanol placed in a pan, measuring 305 mm, that was placed at floor level. This represented a small, low-heat release, flaming ignition source with minimal impact on sprinkler activation. The alcohol fire was started with an electric igniter that was remotely operated.

Instrumentation

Thermocouples were mounted at various locations in the test facility to monitor the temperatures within the stack array and at the ceiling. The locations of the thermocouples for the tests with pendent sprinklers (Tests 1 and 2) and for the tests with sidewall sprinklers (Tests 3, 4, and 5) are shown in Figure G.1(f) and Figure G.1(g), respectively.

Thermocouples were mounted at two levels within the stack array, as shown in Figure G.1(h). These thermocouples not only monitored the temperature within the stack array, but also gave an indication of fire spread along the row of fire origin and between mobile shelving units. (A particular concern noted during the evaluation of the hazard in the library was the possibility of a shielded fire in the lower levels spreading horizontally into adjacent shelving units.) The thermocouples were installed with the wire attached to the center of a shelving section and the thermocouple bead 12.5 mm below the outer edge of the shelf to measure the air temperature in the open space between two levels of shelving. The thermocouples were cross-referenced to the alphanumeric system used for labeling the shelving sections [see Table G.1(c)] with the shelving designation indicating that the thermocouple was positioned in the open space above the storage on the specified shelving section. In Test 1, for example, Thermocouple 20, shown in Figure G.1(f), was located in the open space above the boxes on Shelf H13 and was thus at midlevel in the shelving unit directly above the initial fire source.

For Tests 3, 4, and 5, four thermocouples were used to monitor the temperature on the non-fire side of the barriers that were installed in the center of the two mobile units on either side of the fire source. These thermocouples are labeled 30, 31, 32, and 33 in Figure G.1(g). For each barrier, thermocouples were placed on the vertical centerline of the barrier at mid-height and at the fifth shelving level above the floor.

Thermocouples were also placed near each sprinkler. These thermocouples were used to not only monitor the temperatures at the ceiling, but also to record when the sprinklers operated. For the on-off sprinklers, the thermocouples were located just below the deflector in the closed position. For all other tests, the thermocouples were located near, but not in contact with, the sprinkler elements.

For all the tests, a thermocouple was located at the ceiling directly above the fire source. For Tests 3, 4, and 5, additional ceiling thermocouples were installed to monitor the temperature above the stack array. The location of these thermocouples is shown in Figure G.1(g).

Provisions were also made to measure the smoke obscuration in the test facility using He-Ne lasers. In all tests, the obscuration was measured at the 1.5 m level in an access aisle. For this measurement, the laser was positioned at one end of the test facility. The measuring diode was positioned at the opposite end of the aisle 8.2 m away. A collimator was used to minimize beam divergence. For all tests, the mobile units were placed close together and positioned near one of the fixed units. This arrangement left a space of approximately 1 m between the other fixed shelf and the nearest mobile unit. In Tests 1 and 2, the smoke obscuration was measured in this open area. For this measurement, the He-Ne laser was mounted at the 1.5 m level at one side wall of the test facility. The detector was positioned at the opposite side of the facility.

Test 1: On-Off Pendent Sprinkler

As indicated previously, the analysis of the hazard in the library indicated that folded newspapers stored in periodical boxes could result in the most rapid fire spread and, thus, the most challenging fire scenario for the sprinklers. For the initial test, the mobile shelving units on either side of the fire source were completely filled with newspapers [Rows G, H, I, and J in Figure G.1(i)]. The remaining shelving rows were filled with partially filled document boxes. The alcohol pan ignition source was located at the center of the closed units between Rows H and I.

After ignition, the flames rapidly involved the newspapers above the fire source. Within 50 seconds, the four pendent sprinklers nearest the fire source — Sprinklers 1, 4, 5, and 6 — were activated [see Figure G.1(f)]. Eventually, Sprinklers 3, 7, and 9 were also activated.

Despite the early response of the sprinklers, the fire continued to spread the length of Rows H and I on all levels and eventually involved the entire fuel load in these rows. There was also very early involvement in Rows F, G, J, and K. Within 6 minutes, it was clear that the sprinklers were not going to control the fire, and the test was terminated.

The lack of control is illustrated by some key temperature measurements. First, the temperature at the ceiling directly above the fire remained above 600°C, even with the four closest sprinklers operating [see Figure G.1(j)]. Second, there was rapid fire spread at the mid-height of the row of fire origin, with sustained flames and temperatures of 800°C throughout the length of the row within 3 minutes 30 seconds [see Figure G.1(k)]. Finally, there was rapid fire spread to the next mobile unit (Row K) with sustained temperatures of 700°C measured at the mid-height within 3 minutes [see Figure G.1(l)]. The temperature measured at the lower level indicated substantial fire penetration within 3 minutes and sustained temperature of 700°C within 5 minutes.

Based on a review of the test observations, videos, and temperature data, the major findings for Test 1 are summarized [as follows].

As expected, the fire involvement of the open, folded newspapers was rapid and sustained, despite early sprinkler activation and the use of relatively high sprinkler flow rates. The high percentage of exposed surfaces of combustibles throughout the stacks resulted in very rapid fire spread along the row of fire origin and to adjacent shelving units.

The close proximity of the fuel on adjacent shelves, with the shelves in the closed position, allowed the fire to spread readily without the sprinkler spray being able to penetrate and cool the fire. Sustained temperatures of 700°C and higher were measured within the stack array.

It was also noted that tremendous quantities of smoke were generated during the test. The entire 20,400 m³ volume of the burn hall was filled within a few minutes of ignition. It is possible that the ink content of the newspapers contributed to the production of the thick, dark smoke. It was also noted that the cooling effect provided by the sprinklers resulted in a more rapid build-up of smoke at lower levels of the burn hall. This smoke could present a threat to evacuation in the area of the fire and would probably make it difficult for the fire brigade to gain access to the area, find the fire, and complete extinguishment.

Test 2: Quick Response Pendent Sprinklers

Based on the results of Test 1, it was determined that it would be necessary to change the sprinkler arrangement to provide a more effective water spray coverage to the shelving area. In addition, it was determined that a part of the fire protection strategy would have to include modifications to the shelving units.

Three specific changes were incorporated into the test arrangement for Test 2. First, quick response pendent sprinklers were used for all areas of the test facility instead of on-off sprinklers. Second, the “worst-case” scenario with newspapers stored in open boxes was eliminated. It was recommended that the newspapers be stored in closed-top, corrugated cardboard document boxes similar to those used to store other materials. Third, sheet metal would be used to subdivide the shelving units lengthwise. It was expected that these barriers would act as firestops to slow the spread of fire between the rows of shelving. For Test 2, barriers were installed in the two fixed shelving units and in the center mobile unit, thus separating rows, AB, GH, and MN.

All other conditions in Test 1 applied, except that it was considered unnecessary to completely load rows A, B, C, D, E, M, and N. The fire protection system would be deemed to have failed if the fire spread to these rows, and the test would be stopped. However, empty boxes were placed on the top level of all these shelving rows to ensure that the spray distribution from the sprinklers would not be compromised. The sprinkler flow rates were established to maintain a minimum density of 18.7 (L/min)/m^2 , the same as that used in Test 1.

After ignition, the initial fire developed in the same pattern as the fire in Test 1, with a very rapid vertical fire spread on the boxes on Rows H and I above the ignition source. The four pendent sprinklers closest to the fire operated at approximately 50 seconds. Several aisle sprinklers activated later.

The spread of fire along the length of Rows H and I was very rapid and nearly as intense as the fire in Test 1 [see Figure G.1(m)]. These results indicate sustained burning, with temperatures greater than 800°C at the mid-level of these rows after 6 minutes. There was also rapid fire spread to the adjacent rows (Row K) that were not protected by the steel barrier. This is illustrated in Figure G.1(n), where sustained burning is indicated at the mid-level of Row K after 5 minutes and at the lower level after 9 minutes.

The fire barrier between Rows G and H delayed the fire spread to Row G. Figure G.1(o) indicates that the barrier was penetrated at approximately 10 minutes, with sustained burning after 12 minutes.

The ceiling temperature directly above the ignition source is shown in Figure G.1(p). After an initial “knockdown,” the ceiling temperature increased slowly as the fire began to involve more fuel. Despite the continued operation of the sprinklers, the ceiling temperature began to increase rapidly after 6 minutes; sustained temperatures greater than 800°C were reached within 10 minutes.

Based on a review of test observations, videos, and temperature data, the major findings for Test 2 are summarized as follows.

First, with the mobile shelving units close together, the faces of the document boxes touched. The close-packed document boxes in adjoining units prevented sprinkler spray from reaching the burning fuel package stored on lower shelving levels. Despite the early response of the sprinklers, there was minimal “prewetting” of the boxes on the shelving rows adjacent to the fire rows.

Second, there was relatively rapid fire spread on the corrugated cardboard document boxes, even though the removal of the open newspaper storage decreased the initial fire growth rate. The rapid involvement in the lower shelving levels allowed the fire to overcome the limited firestopping benefits of the single sheet-steel barrier. This barrier did delay fire spread by approximately 7 minutes, however.

Third, this storage represents a significant fire load, even though the boxes were only partially filled with documents. There was considerable structural damage to the shelving frames, and the shelves in the central portion of Rows I and J collapsed completely.

Test 3: Quick Response Horizontal Sprinklers

Test 3 was primarily intended to examine the ability of QR horizontal sidewall sprinklers to protect the shelving array [see Figure G.1(e)]. QR pendent sprinklers were used to protect the aisle areas.

As a result of the analysis of Test 2, three further changes were made for this test. First, the fire barrier separating Rows G and H was upgraded to improve fire resistance. The barrier consisted of mineral insulating board 12.5 mm thick sandwiched between two 26-gauge sheet steel panels. In addition, a fire barrier consisting of two layers of 26-gauge sheet steel separated by a 3 mm air gap was installed between Rows I and J.

Next, spacers were used to prevent the mobile shelving units from closing so that adjacent storage touched. In this manner, a minimum 26 mm gap was maintained between the boxes stored on adjacent shelves.

Finally, the water flow rate was increased to provide a minimum density of 28.5 (L/min)/m^2 over the mobile shelving units.

After ignition, the initial fire developed in the same pattern as it did in Tests 1 and 2, with a very rapid vertical fire spread on the boxes on Rows H and I above the ignition source. The three closest horizontal sidewall sprinklers and one aisle sprinkler — Sprinklers 1, 4, 5, and 7 — operated between 1 minute 15 seconds and 1 minute 22 seconds after ignition [see Figure G.1(g)]. The sprinklers were able to control and extinguish the fire quickly. This is illustrated by the rapid decrease in temperatures measured at the mid-level of Row H [see Figure G.1(q)] and at the ceiling directly above the fire [see Figure G.1(r)]. The fire damage was limited to the center portions of Rows H and I.

The horizontal sidewall sprinklers, in combination with the fire barriers and the 26 mm gap between the mobile units, allowed for effective cooling and extinguishment in the initial area involved in the fire. Further, the high spray density, combined with the favorable water spray projection pattern, provided cooling at the ceiling and prevented the operation of an excessive number of sprinklers.

Test 4: Quick Response Horizontal Sprinklers at Lower Density

Test 4 was arranged to duplicate the conditions in Test 3, except the water flow rate was reduced. The initial flow rate was set to provide a density of 20.5 (L/min)/m².

The initial fire development duplicated the conditions observed in Test 3, with the sprinklers operating at precisely the same time. With the lower flow rate, however, the fire was not immediately extinguished. The temperatures measured at the mid-level of Row H indicate that there was sustained burning at the lower levels of Rows H and I [see Figure G.1(s)]. The thermocouples mounted on the non-fire side of the fire barrier separating Rows I and J indicated that the fire penetrated this barrier at approximately 15 minutes [see Figure G.1(t)]. However, this delay was sufficient to allow water to drip down the 26 mm gap between facing shelves and prewet the boxes on the lower levels. With the extended period of prewetting, the fire did not spread rapidly after breaching the barrier. There was a continued decrease in the temperatures in the stack array throughout the test.

At 25 minutes, the water flow rate was increased to 24.6 (l/min)/m². With the increased flow rate, the fire was extinguished within 5 minutes.

The results of Test 4 indicated that, with the reduced water application density, the HSW sprinklers were unable to rapidly extinguish the fire. However, the fire barriers limited initial fire spread, allowing for an extended period of prewetting throughout all levels of the shelving. The continued decrease in temperatures indicated that the sprinklers were able to control the fire. It is probable that the fire would have been extinguished eventually.

Taking into consideration the importance of limiting fire and water damage to the archival material, it was decided to recommend use of the higher density used in Test 3 to ensure complete extinction in the shortest possible time. This provided for a considerable degree of engineering safety for the system. In addition, the fire barriers and spacer blocks on the mobile shelving bases allowed effective prewetting of the fuel on the shelves surrounding the fire and were thus essential elements in the fire protection system.

Test 5: Quick Response Horizontal Sidewall Sprinklers with Reduced Clearance

As noted previously, the clearance between the top of the storage and the ceiling in some areas in the library was 76 to 100 mm. To address this reduced clearance, a fifth test was conducted to determine whether the sprinkler system could control the fire with less clearance. For this test, the top storage was raised to within 100 mm ± 25 mm of the ceiling.

The horizontal sidewall sprinklers were installed with the deflectors within 50 mm of the ceiling [see Figure G.1(u)]. All other conditions were the same as those in Test 3.

The initial fire development replicated that observed in Tests 3 and 4. However, the close proximity of the storage to the ceiling affected the convective flow above the shelving, so that one of the three sidewall sprinklers closest to the fire did not operate for several minutes. This was Sprinkler 4, which was located on the soffit at the center of the stack array [see Figure G.1(g)]. It did not operate until 9 minutes into the test. The other two sprinklers located on the soffit operated within 90 seconds, even though Sprinkler 3 was located considerably further from the ignition source than Sprinkler 4.

As is shown in Figure G.1(v) and Figure G.1(x), the fire was able to regain some momentum approximately 8 minutes into the test, with high temperatures, measured in shelving Row H and at the ceiling. Once Sprinkler 4 activated at 9 minutes, the sprinklers were able to control and extinguish the fire. The 15 minutes required for the sprinklers to control the fire provided the fire with enough time to break through the fire barrier separating Rows G and H. However, the ability of the sprinkler system to regain control of the fire indicates that there is an inherent safety margin in the protection system.

Substantially more damage was sustained in this test than in Test 3. Based on the results of Test 5, it was decided that the 178 mm clearance between the ceiling and the top of the storage used in Test 3 would be specified as the minimum for general use. However, it was also noted that control, and eventually extinguishment, was obtained with the reduced clearance of 100 mm.

Smoke Production

As an additional point of interest, it was observed that large quantities of smoke were produced during all five fire tests, particularly in those tests in which the sprinklers could not immediately extinguish the fire. It was also noted that the cooling of the smoke by the sprinklers resulted in a very rapid build-up at lower levels. This is illustrated by the smoke obscuration measurements from Test 1 shown in Figure G.1(w), which shows a very rapid increase in obscuration at the 1.5 m level within 2 minutes 30 seconds of ignition. In low ceiling spaces, smoke build-up could be very fast and could rapidly obscure exit routes, making it very difficult for the fire brigade to operate in the floor area.

Design Criteria

As a result of these investigations, criteria were recommended for the design of the sprinkler systems over the mobile shelving in the basement of the library. These criteria were based on the findings from spray distribution tests, sprinkler activation tests, a survey and analysis of existing stack systems and fuel loads, and a series of full-scale fire tests involving stack systems with document storage and shelving.

It is beyond the scope of this paper to provide a detailed description of the design criteria recommended for the library. However, the general principles used to develop the design guide are summarized.

Modifications to the Shelving Units

The full-scale fire tests indicated that it would be very difficult or impossible to control a fire in the compact shelving area using only sprinklers. Several modifications to the shelving units and storage practices were recommended as essential aspects of the fire protection system.

Provisions should be made to ensure that a minimum clearance of 26 mm is maintained at all times between document boxes or other materials on adjacent mobile shelves when they are moved to the “closed” position. The purpose of the 26 mm space is to permit sprinkler water to drip down the face of shelving materials, thus ensuring good wetting at lower levels.

Each back-to-back stack unit should be subdivided lengthwise with a steel firestopping barrier that extends the full length and height of each section of the mobile and fixed stack units. These barriers will inhibit rapid fire spread through intermediate levels to adjacent shelving units. The barriers were of particular importance immediately after sprinkler operations, when the rapid cooling at the ceiling level tends to cause large horizontal flame extension at various levels within the shelving units. The barriers also delay the spread of fire into adjacent shelves and provide time for sprinkler water to drip down the 26 mm space between shelves to wet the lower levels. If fire penetrates the barrier, it encounters prewetted fuel and does not grow as rapidly.

Newspapers should no longer be stored in open periodical boxes. During Test 1, it was noted that the newspaper hazard exposed a large quantity of loosely packed fuel to the fire. This resulted in a rapid lateral fire spread within the shelving unit which allowed the fire to involve a large quantity of fuel during the initial fire growth. By eliminating the open newspaper scenario, the initial fire growth was reduced, thus decreasing the fire challenge for the sprinkler system.

Sprinkler System Design

The design criteria for the sprinkler system is based on the sprinkler configuration used in Test 3. In this configuration, six quick response pendent sprinklers with 57 to 77°C ratings, nominal 12.5 mm orifices, K factors of 5.3 to 5.8 in U.S. units, and a 3.05 m spacing were used to protect the aisle. Five quick response horizontal sidewall sprinklers with 57 to 77°C ratings, nominal 12.5 mm orifices, and K factors of 5.3 to 5.8 in U.S. units were used to protect the mobile shelving area.

The layout for the horizontal sprinklers is designed to maximize water spray coverage and to minimize the possibility of spray from one sprinkler delaying the activation of adjacent sprinklers. To achieve this, the sprinklers are arranged in a staggered array on opposite sides of the shelving units. The spray distribution tests demonstrated that, with the geometry used in this test series, there was no direct spray impingement on a sprinkler from adjacent sprinklers. As a result, reproducible activation of the three sprinklers closest to the fire source was obtained in Tests 3 and 4, the two tests with the 178 mm clearance between the ceiling and the storage.

The horizontal sidewall sprinklers are arranged to maximize water spray coverage in critical shelving areas. On the side of the stack array with three sprinklers, the two end sprinklers are centered on the gap between the fixed shelving unit and the first mobile unit. This ensures maximum water spray penetration into the one area where, because of the stops installed on the rails, relatively good penetration of water spray to the lower

shelving levels was possible. The third sprinkler on that side is located at the center of the shelving array, giving a 2.6 m spacing between the sprinklers. The two sprinklers on the opposite side of the stack array are staggered so as to be exactly halfway between the two sprinklers on the opposite side, 4.5 m away. The spray distribution tests showed that, with the horizontal sprinklers mounted a nominal 100 mm below the ceiling, the sprinklers were able to provide uniform wetting over the entire mobile shelving area.

Even with the newspaper scenario removed, relatively fast fire development was observed in the full-scale fire tests. The results of Tests 3 and 4 demonstrated that, in order for the sprinklers to control the fire and minimize damage to the shelving contents, it was essential that water be applied as early as possible with a relatively high spray density. For this reason, it is recommended that a wet pipe sprinkler system be used in the library.

Two levels of coverage are needed for the design of the sprinkler system:

- (1) A minimum average density of 28.5 (L/min)/m² from five HSW sprinklers over a single bay of compact shelves. Each sprinkler is assumed to cover approximately 5.92 m².
- (2) A minimum average density of 12.3 (L/min)/m² over a 139 m² design area. This design area includes both sidewall sprinklers and pendent aisle sprinklers.

Such a system will provide the high application density required to control the rapidly developing fire in the shelving area while minimizing the demand on the water supply system.

For Test 5, the clearance between the storage on the mobile shelving units and the ceiling was 100 mm ± 25 mm. The HSW sprinkler deflectors were located 50 mm below the ceiling. This test showed that a fire could be controlled for this scenario. However, this test also showed that localized cool areas may occur above the mobile units, delaying the activation of some sprinklers and thus increasing fire spread and fire damage. The delay in controlling the fire could result in the activation of an increased number of sprinklers. Because the reduced clearances increased the potential fire and water damage to the contents of the shelving, it was strongly recommended that the sprinkler layout conform to the conditions used in Test 3 whenever possible — that is, that a 178 mm clearance be maintained between storage and the ceiling.

Summary

This paper provides a technical solution for sprinkler protection of the compact shelving units in the basement of the National Library of Canada. The fundamental basis for accepting an equivalent to a sprinkler installation that conforms to the standards is that the proposed arrangement demonstrate a high probability that it can extinguish or control the fire in the fuel package. Based on this criterion, the sprinkler layouts with pendent sprinklers used Tests 1 and 2 did not provide an acceptable level of performance.

The sprinkler layout in Test 3, which used horizontal sidewall sprinklers and a high spray density to protect the mobile shelving units, extinguished the fire with minimal fire damage to the shelving contents. This system formed the basis for general design criteria for shelving units in which the clearance from the top of the document boxes to the ceiling was at least 178 mm.

Tests 4 and 5 investigated the boundary conditions for the sprinkler system and showed that the average density and the clearance height above the shelving unit used in Test 3 were critical elements in determining the performance of the sprinkler system. In these tests, the sprinkler system took longer to control and eventually extinguish the fire, which resulted in greater damage to the stack's contents.

The effectiveness of the sprinkler system, as outlined in this paper, depended on implementing all the recommendations noted: vertical fire barriers in all shelving units, bumpers or other measures to ensure a minimum 26 mm clearance between commodities on adjacent mobile shelving units, and no storage of newspapers in open document boxes.

It should be emphasized that this was an engineering study directed at developing a sprinkler system that would provide protection equivalent to that provided by a system in full compliance with standards. This investigation did not evaluate all alternative sprinkler arrangements or the impact of all parameters on the effectiveness of the fire protection system.

Although useful information can be inferred from these tests, the criteria presented in this paper are intended to apply to the conditions found in the National Library of Canada. The technology outlined can certainly form the basis for fire protection systems for other situations, including retrofits where it is difficult to obtain explicit compliance with current installation standards. However, changes in types of storage, ceiling construction, and room elevations could all influence a sprinkler system's ability to control a fire. The authors suggest, therefore, that considerable caution be used in adapting the solutions presented here for other applications and suggest that full-scale fire testing be required if any major changes are made to the design.

Acknowledgment

The authors acknowledge the contribution of G.P. Crampton in carrying out the fire tests. Thanks are also due D.W. Carpenter, V.F. Fortington, R.A. MacDonald, B.C. Taber, M. Ryan, and M. Wright, who assisted in the tests.

Footnote

†Certain commercial products are identified in this paper in order to adequately specify the experimental procedure. In no case does such identification imply recommendations or endorsement by the National Research Council, nor does it imply that the product or material identified is the best available for the purpose.

References

- (1) NFPA 13, *Standard for the Installation of Sprinkler Systems*, National Fire Protection Association, Quincy, MA, 1989.
- (2) *National Building Code of Canada*, National Research Council of Canada, Ottawa, Canada, 1990.
- (3) Chicarello, P. J., Troup, J. M., and Dean, R. K., *Fire Tests for Mobile Storage Systems for Archival Storage*, Technical Report JJ. 3A2NrRR, Factory Mutual Research Corporation, Norwood, MA, 1978.
- (4) O'Neill, J., private communication.
- (5) Nelson, H. E., *FPETOOL: Fire Protection Engineering Tools for Hazard Assessment*, NBSTIR 90-4380, National Institute of Standards and Technology, Gaithersburg, MD, 1990.

Table G.1(c) Thermocouple Locations

Channel Number	Location Tests 1 and 2	Location Tests 3, 4, and 5
1	Sprinkler 1	Sprinkler 1
2	Sprinkler 2	Sprinkler 2
3	Sprinkler 3	Sprinkler 3
4	Sprinkler 4	Sprinkler 4
5	Sprinkler 5	Sprinkler 5
6	Sprinkler 6	Sprinkler 6
7	Sprinkler 7	Sprinkler 7
8	Sprinkler 8	Sprinkler 8
9	Sprinkler 9	Sprinkler 9
10	Sprinkler 10	Sprinkler 10
11	Sprinkler 11	Sprinkler 11
12	Sprinkler 12	Shelving Section H1
13	Shelving Section H1	Shelving Section H2
14	Shelving Section H2	Shelving Section H3
15	Shelving Section H3	Shelving Section H4
16	Shelving Section H4	Shelving Section H5
17	Shelving Section H5	Shelving Section H11
18	Shelving Section H11	Shelving Section H12
19	Shelving Section H12	Shelving Section H13
20	Shelving Section H13	Shelving Section H14
21	Shelving Section H14	Shelving Section H15
22	Shelving Section H15	Shelving Section J3
23	Shelving Section M2	Shelving Section J12
24	Shelving Section M3	Shelving Section J13
25	Shelving Section M4	Shelving Section J14
26	Shelving Section M13	Shelving Section G3
27	Shelving Section K3	Shelving Section G12
28	Shelving Section K13	Shelving Section G13
29	Shelving Section G2	Shelving Section G14
30	Shelving Section G3	G13 Barrier (non-fire side)
31	Shelving Section G4	G23 Barrier (non-fire side)
32	Shelving Section G13	J13 Barrier (non-fire side)
33	Shelving Section E3	J23 Barrier (non-fire side)
34	Shelving Section E13	Ceiling
35	Shelving Section C3	Ceiling
36	Ceiling above ignition source	Ceiling
37		Ceiling
38		Ceiling above ignition source

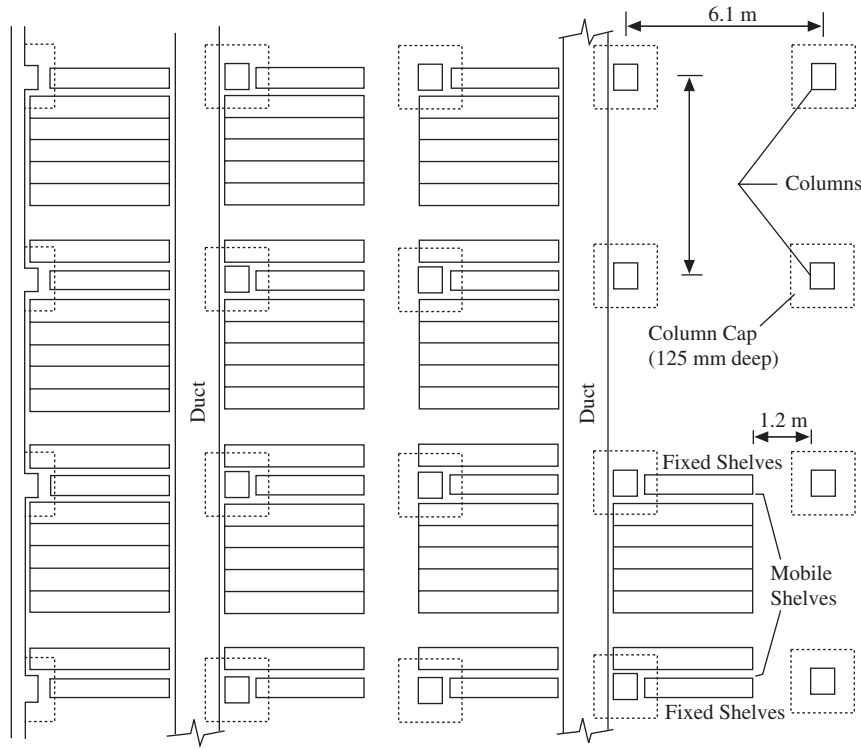

PLAN

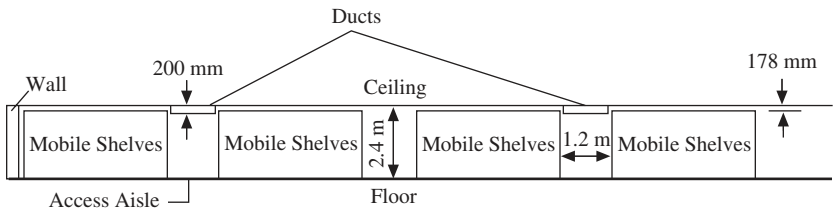

ELEVATION

FIGURE G.1(a) Layout for Basement Levels of National Library of Canada.

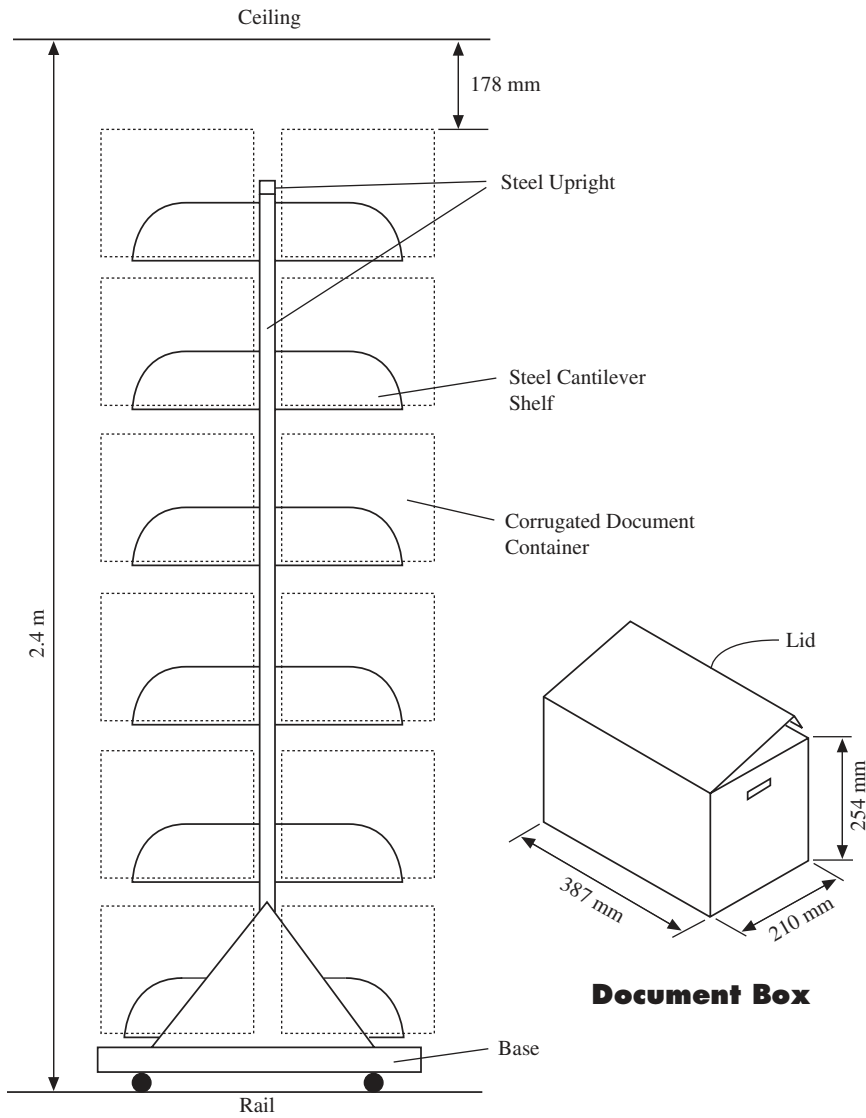

FIGURE G.1(b) End View of Mobile Shelving Unit.

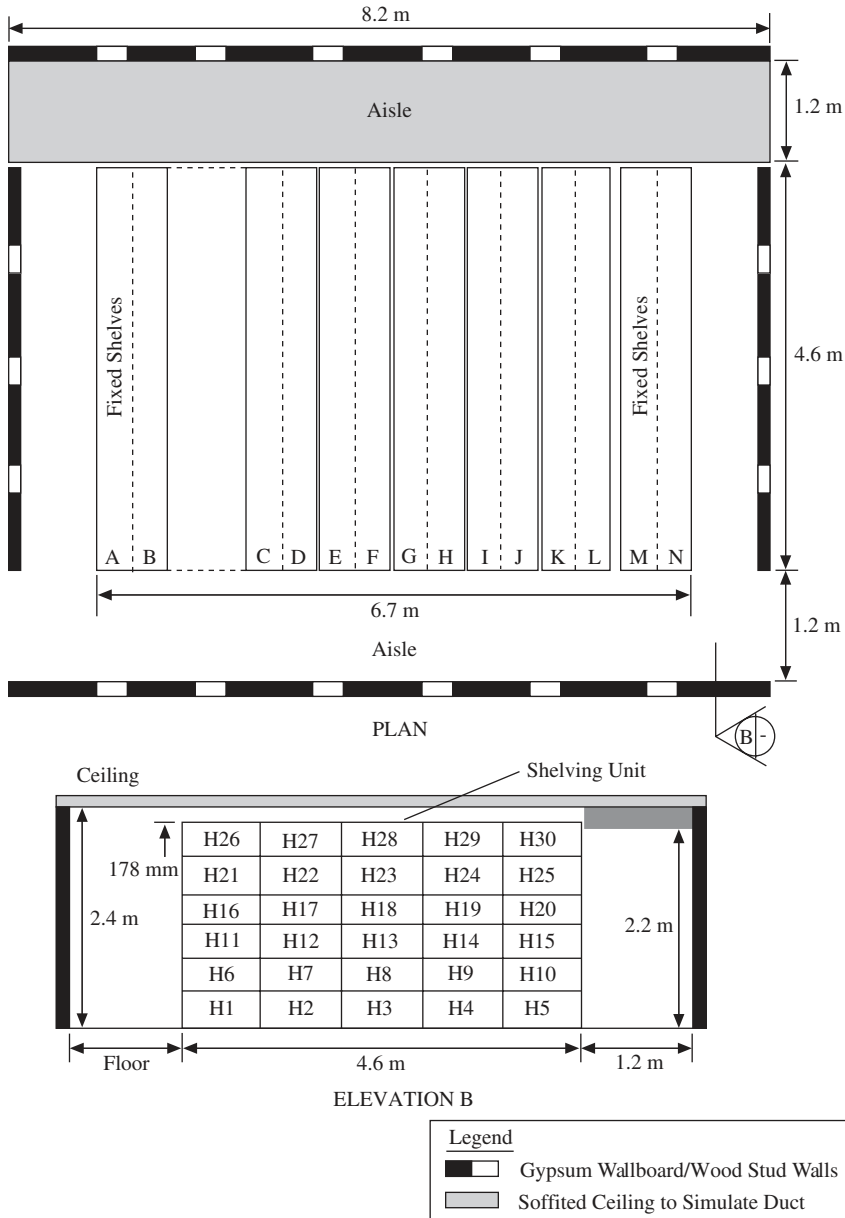

FIGURE G.1(c) Test Facility.

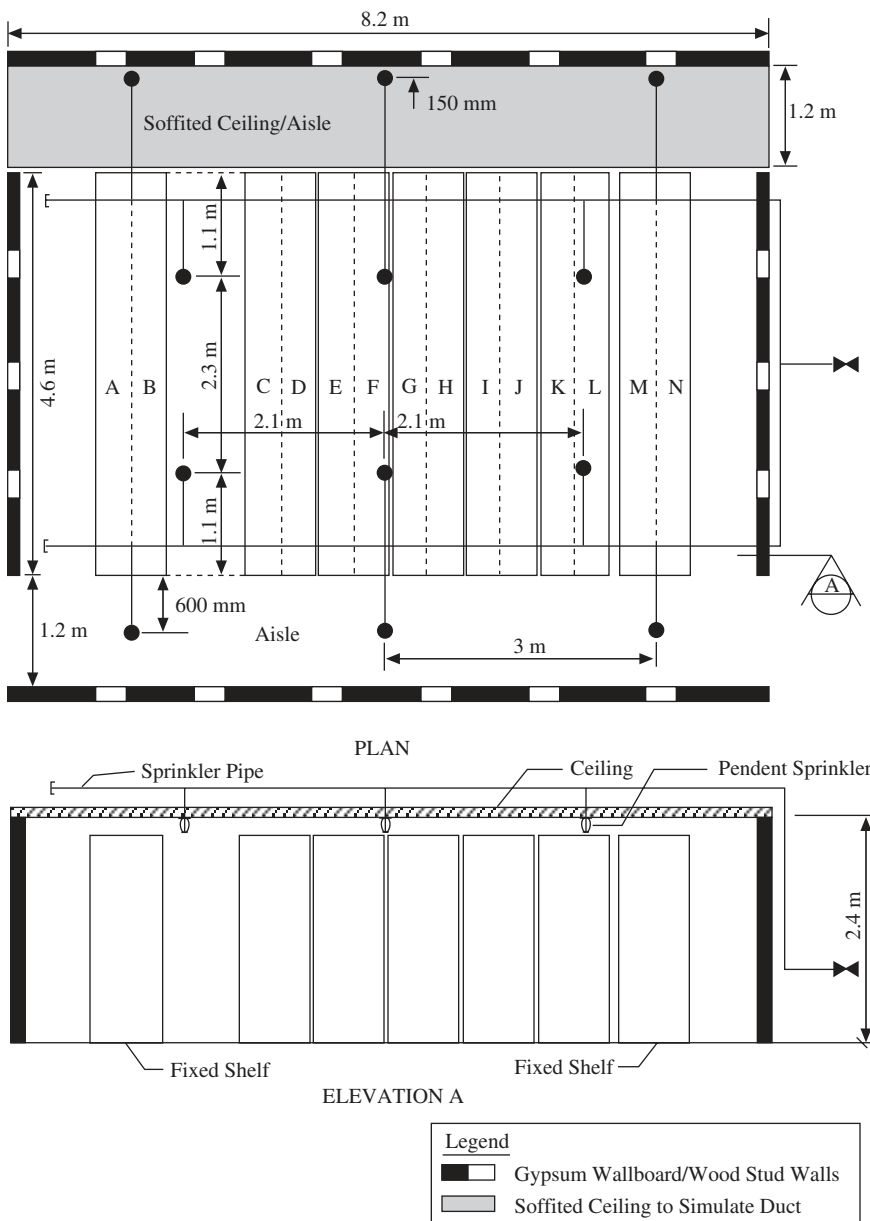

FIGURE G.1(d) Pendent Sprinkler Layout.

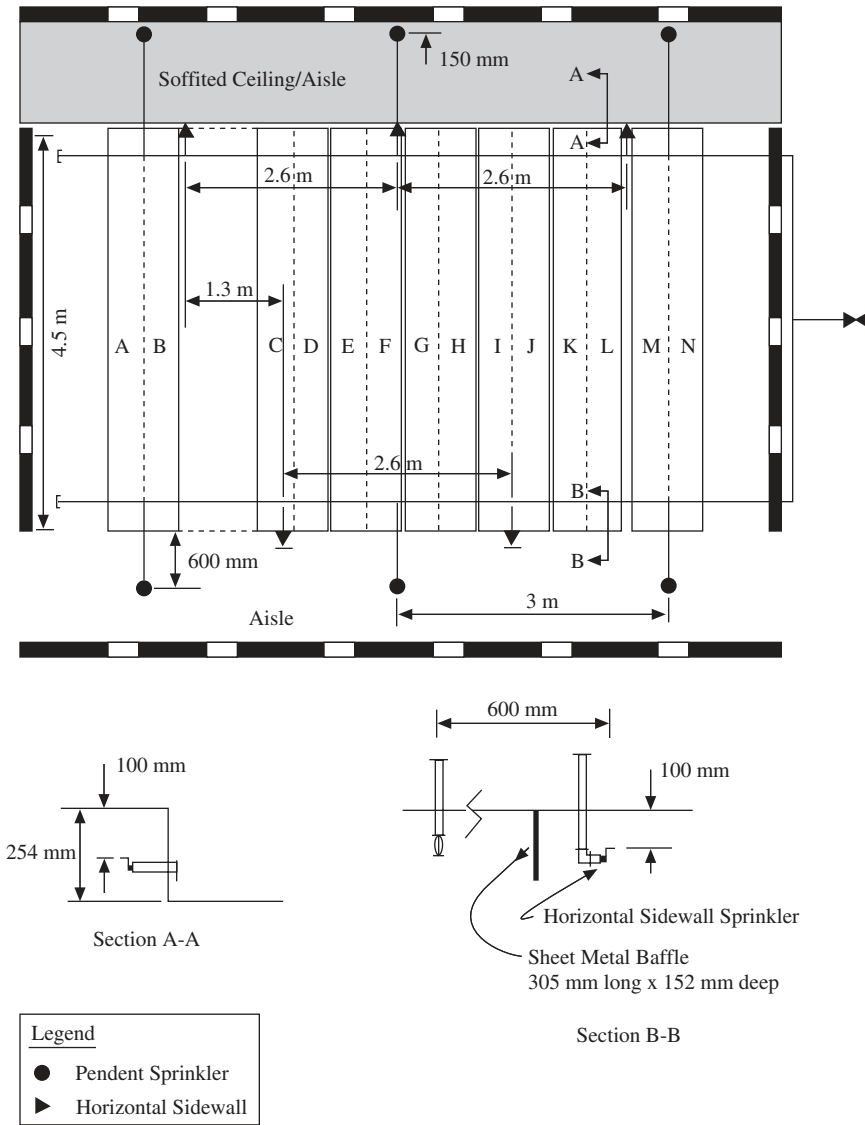
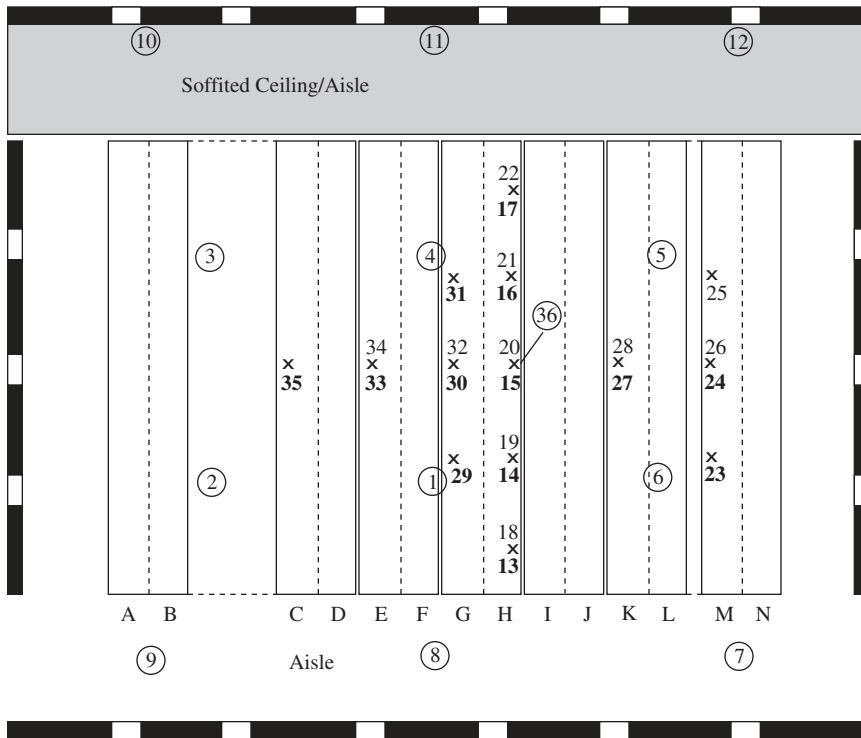

FIGURE G.1(e) Horizontal Sidewall and Pendent Sprinkler Layout.



Thermocouples at Lower Level

13, 14, 15, 16, 17, 23, 24,
25, 27, 29, 30, 31, 33, 35

Thermocouples at Mid Level

18, 19, 20, 21, 22
26, 28, 32, 34

Thermocouples at Ceiling

36

Thermocouples on Sprinklers

1 2 3 4 5 6
7 8 9 10 11 12

FIGURE G.1(f) Thermocouple Locations for Tests 1 and 2.

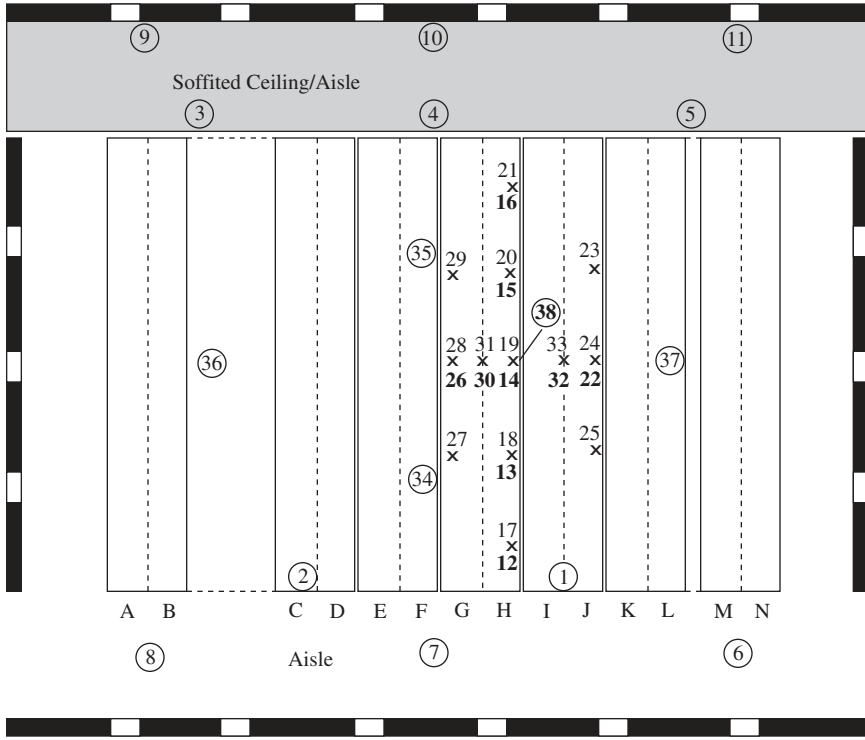

Thermocouples on Barrier

Mid-level **30, 32**
Upper level 31, 33

Thermocouples on Sprinklers

① ② ③ ④ ⑤ ⑥ ⑦
⑧ ⑨ ⑩ ⑪

Thermocouples at Ceiling

③④ ③⑤ ③⑥ ③⑦ ③⑧

Thermocouples at Lower Level

12, 13, 14, 15, 16, 22, 26

Thermocouples at Mid Level

17, 18, 19, 20, 21, 23
24, 25, 27, 28, 29

FIGURE G.1(g) Thermocouple Locations for Tests 3, 4, and 5.

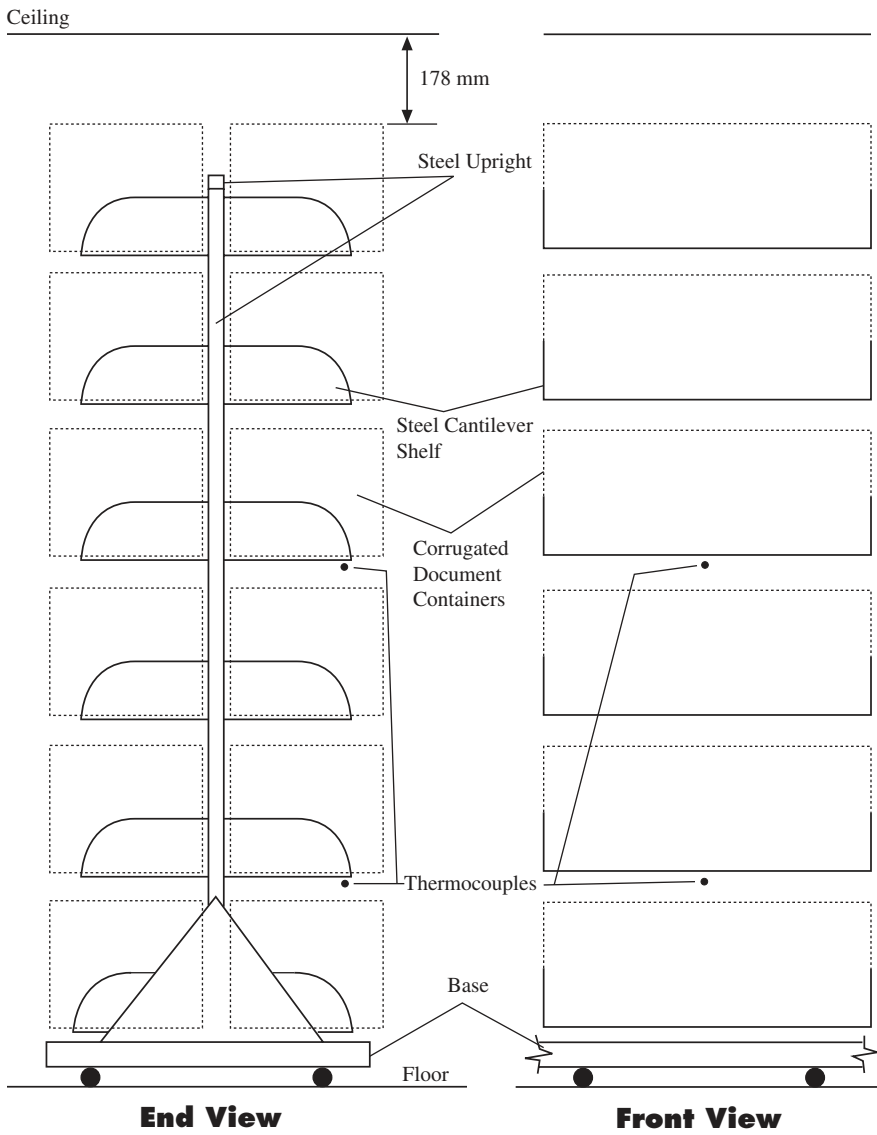

FIGURE G.1(h) Thermocouple Locations on Mobile Units.

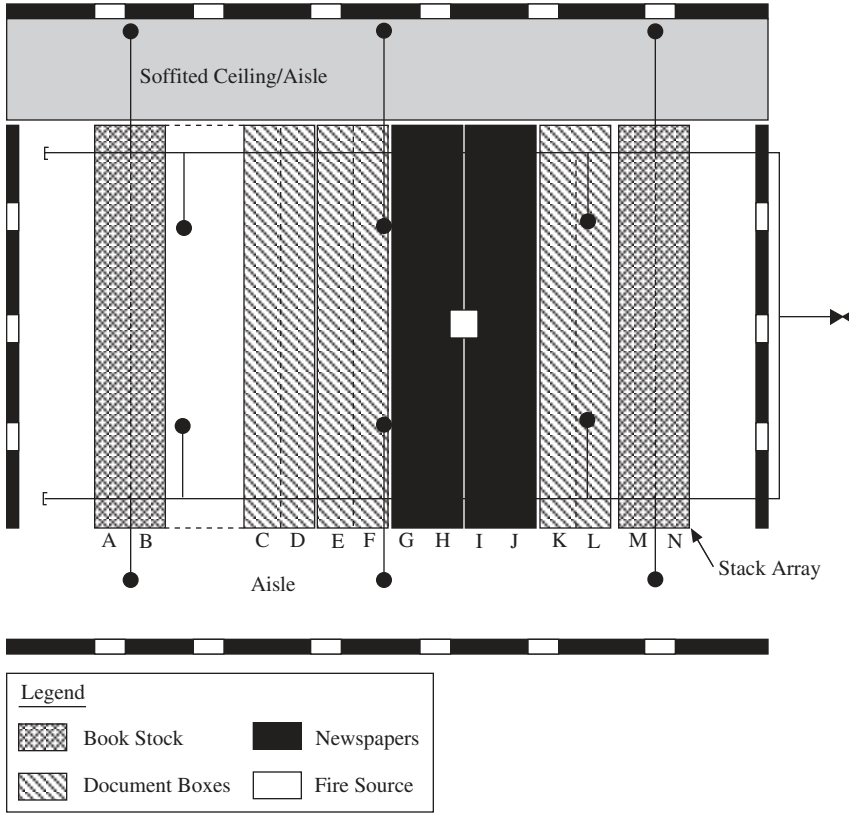

FIGURE G.1(i) Fire Scenario for Test 1.

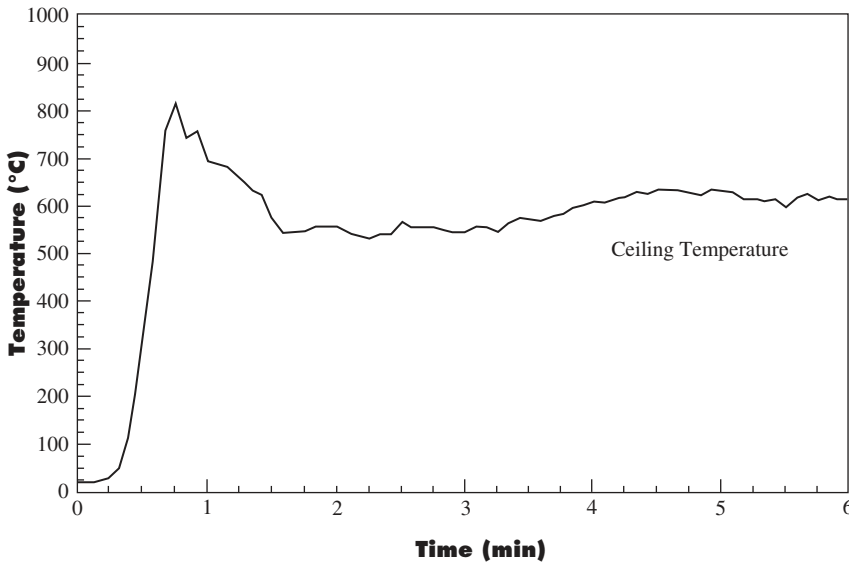

FIGURE G.1(j) Ceiling Temperature in Test 1.

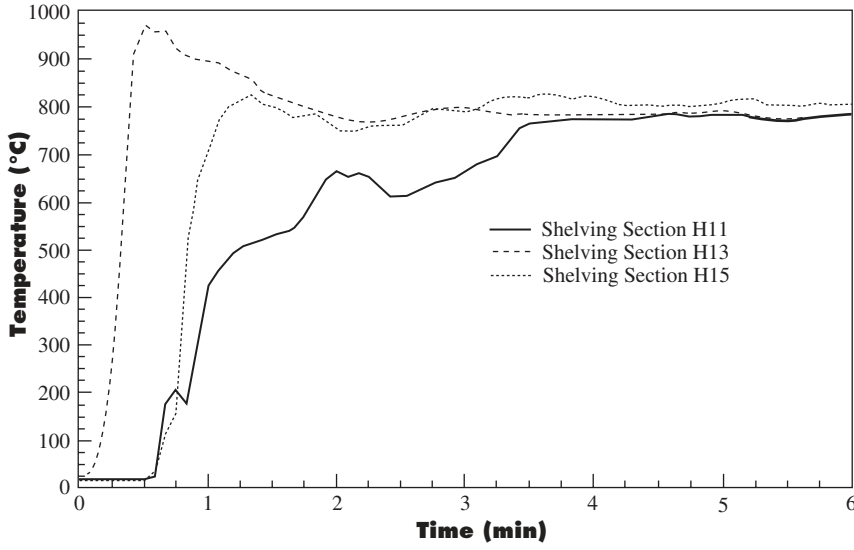

FIGURE G.1(k) Shelving Section H Temperatures in Test 1.

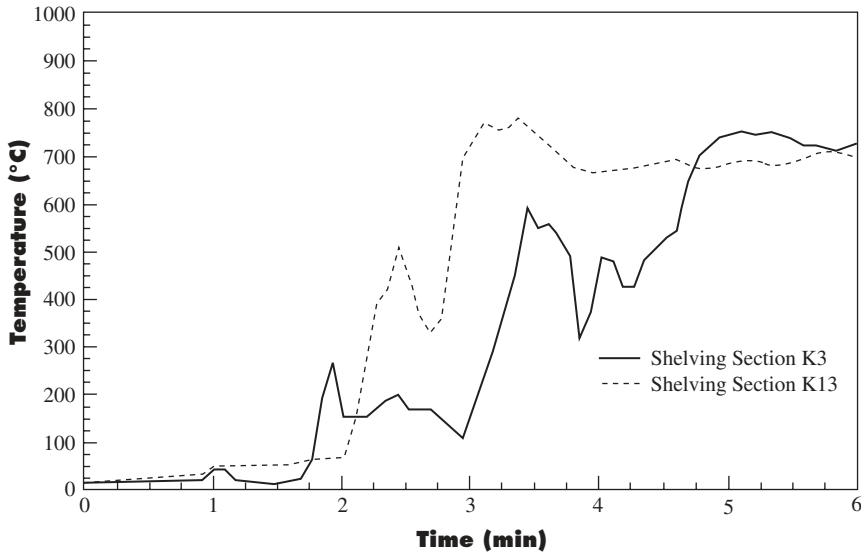

FIGURE G.1(l) Shelving Section K Temperatures in Test 1.

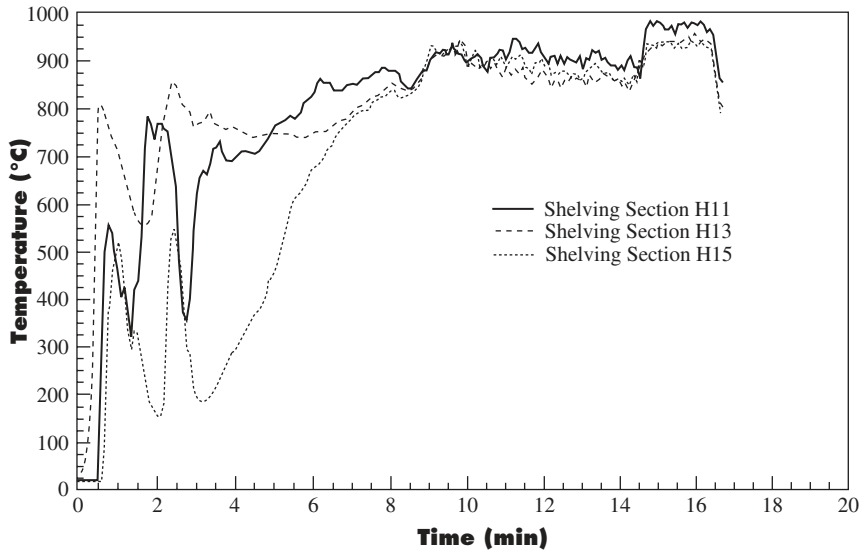

FIGURE G.1(m) Shelving Section H Temperatures in Test 2.

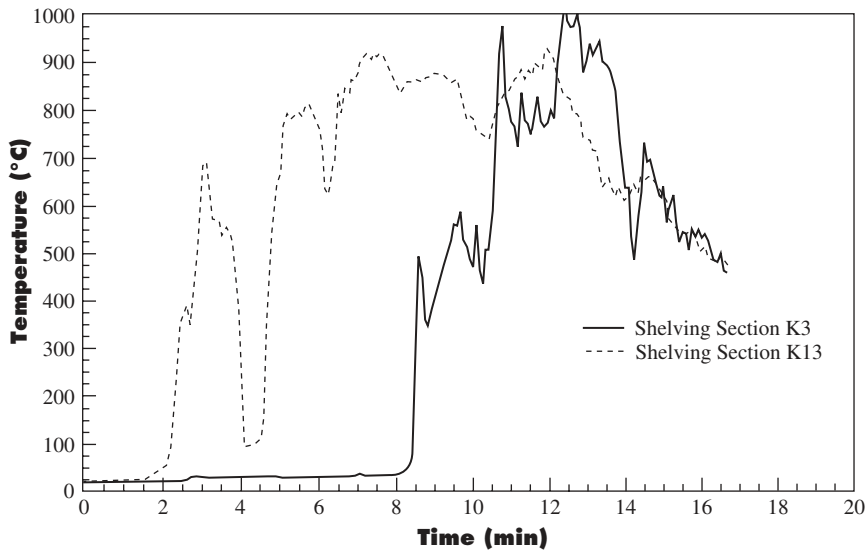

FIGURE G.1(n) Shelving Section K Temperatures in Test 2.

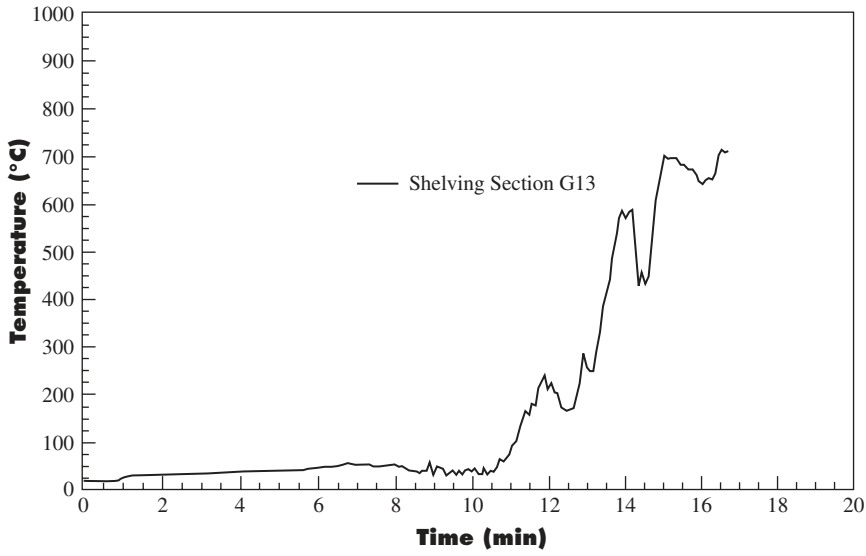

FIGURE G.1(o) Shelving Section G Temperatures in Test 2.

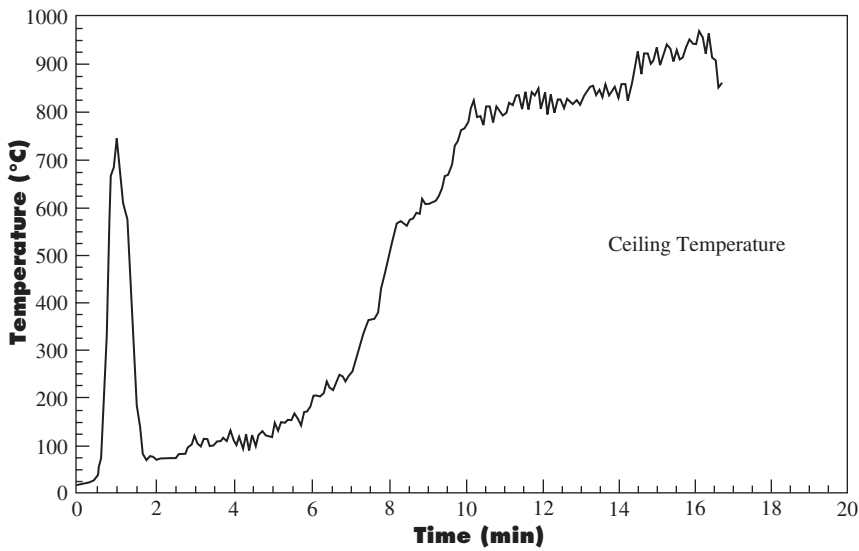

FIGURE G.1(p) Ceiling Temperature in Test 2.

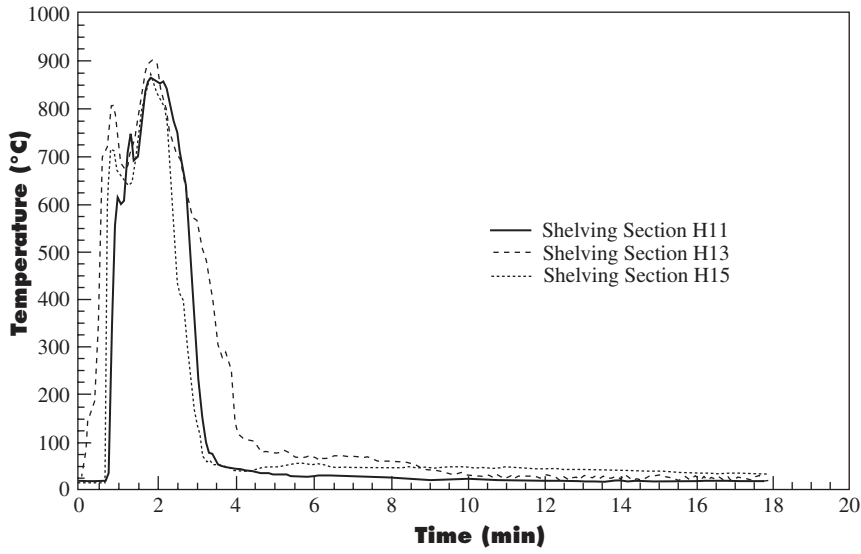

FIGURE G.1(q) Shelving Section H Temperatures in Test 3.

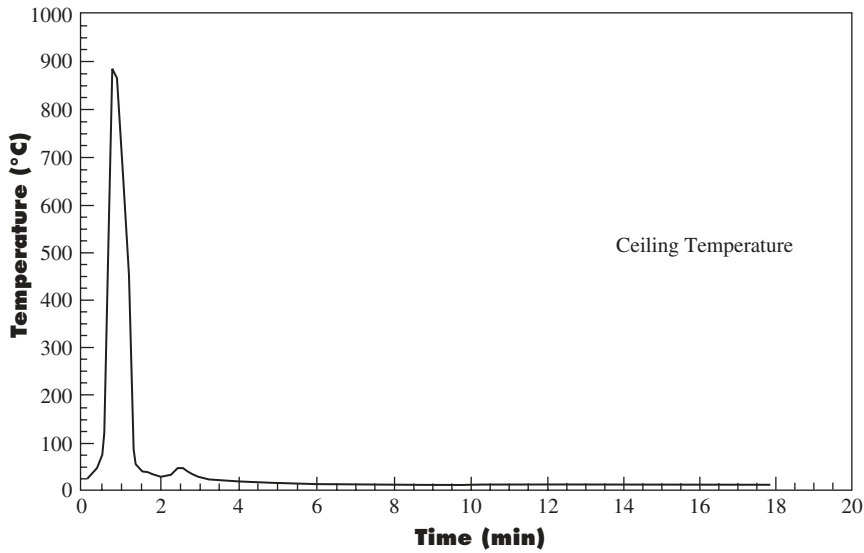

FIGURE G.1(r) Ceiling Temperature in Test 3.

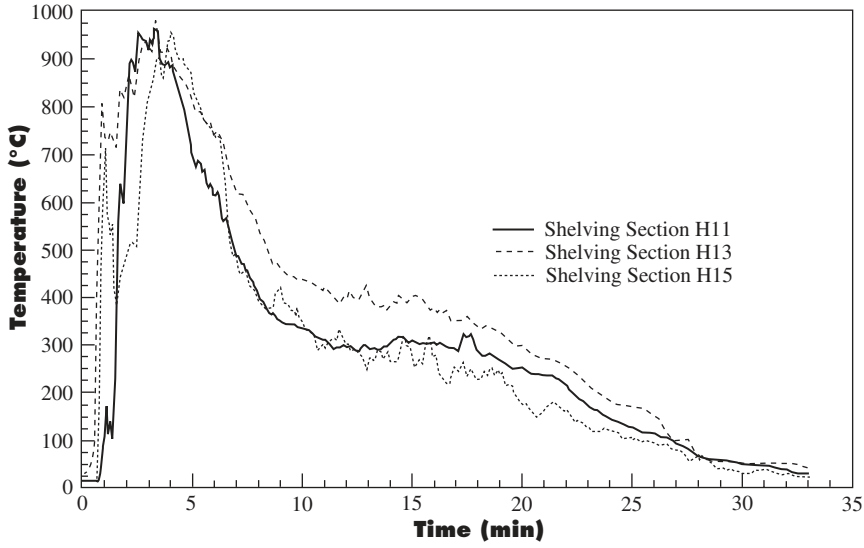

FIGURE G.1(s) Shelving Section H Temperatures in Test 4.

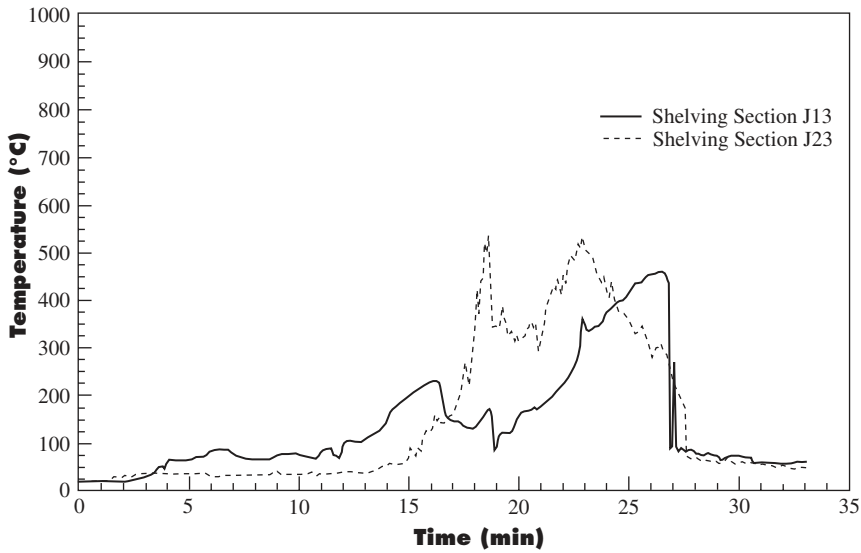

FIGURE G.1(t) Shelving Section J Temperatures in Test 4.

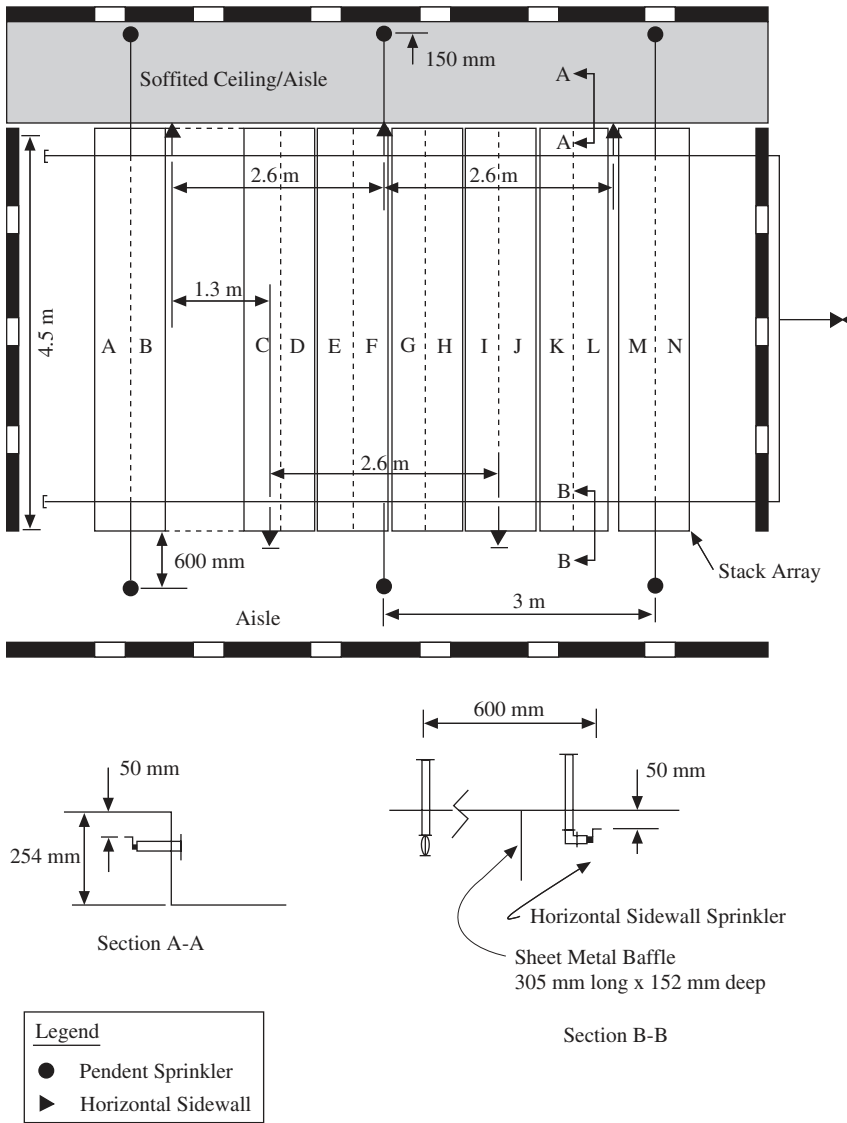

FIGURE G.1(u) Horizontal Sidewall and Pendent Sprinkler Layout for Test 5.

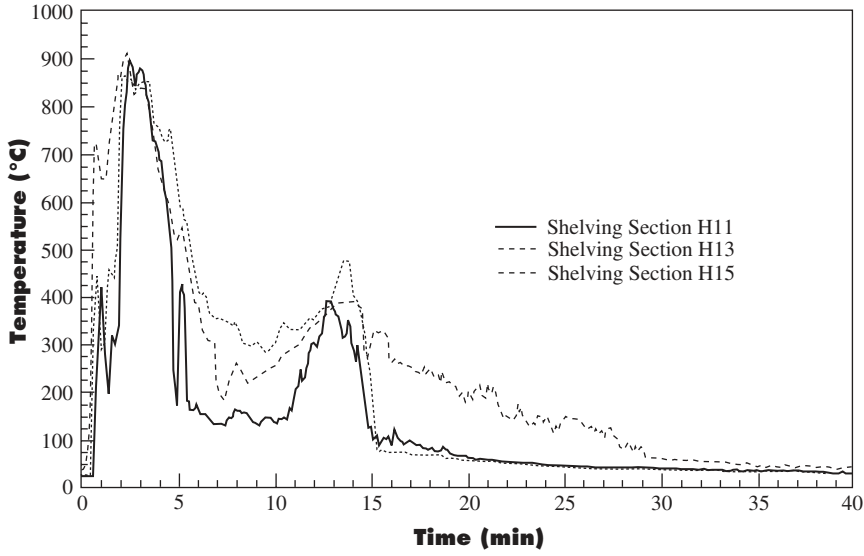

FIGURE G.1(v) Shelving Section H Temperatures in Test 5.

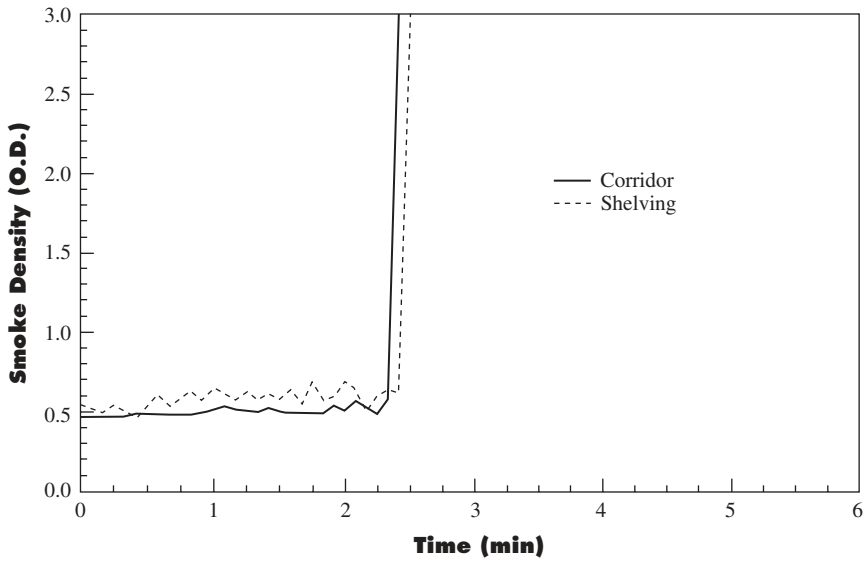

FIGURE G.1(w) Smoke Obscuration at 1.5 m Level in Test 1.

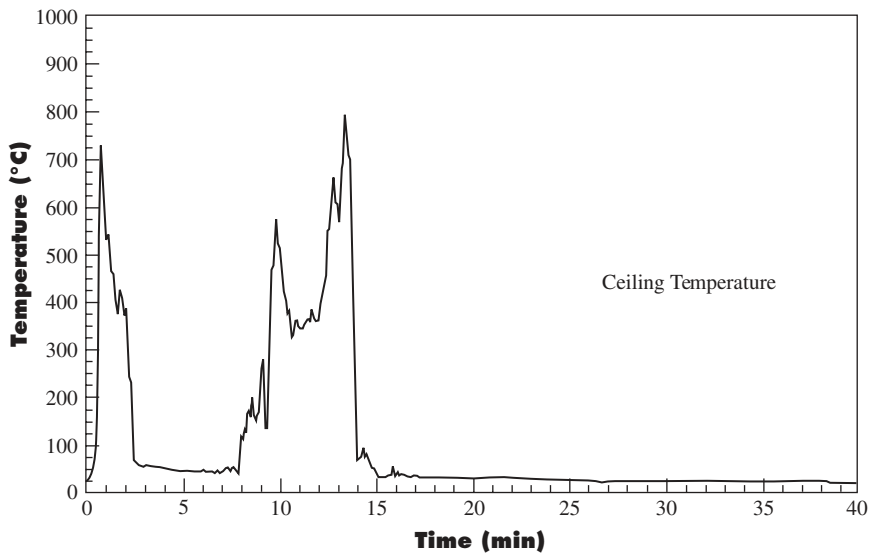

FIGURE G.1(x) Ceiling Temperature in Test 5.

Annex H Compact Storage Test Program

This annex is not a part of the requirements of this NFPA document but is included for informational purposes only.

H.1 The following are excerpts from “Engineering Analysis of Compact Storage Fire Tests” by Harold R. Cutler, an unpublished report prepared by Firepro Inc. for the Library of Congress in 1979.

Abstract

A series of three full-scale tests involving a mobile shelving storage system of the moving aisle type has been conducted by Factory Mutual Research Corporation under contract to the General Services Administration. The objective of the tests was to determine the nature of fire development within archival materials in this storage format and to determine the effectiveness of a specific automatic sprinkler system configuration in controlling that fire development.

These tests show a moderate rate of fire development when ignition involves materials in the open aisle of the storage module and the packing density (number of boxes per shelf) is high. They also show a relatively slow rate of development when ignition is in the closed portion of the module and the packing density of materials is high.

The tests reveal that there is a high probability that automatic sprinkler protection will prevent serious flame and heat damage outside the storage module of origin but will not significantly limit production of smoke and fire gases. The tests also indicate a low probability that automatic sprinkler protection will limit flame involvement to a portion of the storage module of origin in the storage configuration tested.

Several characteristics of the moving-aisle-type compact storage situation are analyzed. Tentative conclusions concerning fire development and fire protection for compact storage based on those characteristics are presented. The most important tentative conclusion drawn is that a combination of carriage subdivision by sheet metal panels and greater vertical openness such as provided by louvered or perforated module tops and shelves should permit limitation of open flaming to a portion of a module.

Several specific tests are proposed to allow assessment of the validity of the tentative conclusions.

Compact Storage Systems — The Problem

High-density storage of files, records, or books has become increasingly popular in recent years as cost considerations force users to seek the higher storage efficiencies available in special arrangements of storage hardware. This type of storage is especially appropriate where only limited access is required to the materials in storage. These storage systems are known by such names as “compact storage,” “mobile shelving,” “moving aisle storage,” or “moving shelf storage.”

There are two principal arrangements of shelving utilized to achieve these higher storage densities. For the purposes of this report, these arrangements are called moving aisle storage and moving shelf storage. These two storage types are described below.

Moving Aisle Storage. In moving aisle storage, several ranges of shelves are placed on carriages between a pair of fixed ranges, as illustrated in Figure H.1(a). Space for a single aisle is also left between the fixed ranges. Access to the shelving of a specific range is obtained by moving the carriages to a position that places the aisle along the specific face of the desired range. In such storage, a typical ratio of aisle space to storage space is 1:10.

Moving Shelf Storage. In typical moving shelf storage, a single fixed aisle serves two or more ranges of shelving on one or both sides of the aisle, as illustrated in Figure H.1(b). The rear range of shelving is fixed. One section of shelves in each of the front ranges is omitted and all other shelves of those ranges are mounted on carriages that allow them to travel to the left and right. Thus, the front ranges of shelves can be moved to permit access to any range of shelves. The ratio of aisle space to storage space in such a system with two ranges of shelving is approximately 1:2.

Typical standard fixed shelving [one 30-in. (762-mm) aisle providing access to two 15-in. (381-mm) shelves] has an aisle-to-storage area ratio of 1:1.

Characteristics Affecting Fire

Several characteristics of compact storage systems are expected to affect the pattern of fire development and the effectiveness of detection and suppression systems (manual and automatic) as compared to standard fixed shelving. These characteristics include the following:

- (1) Module components, especially shelves and module tops that discourage vertical fire development and encourage horizontal fire development
- (2) Module components, especially shelves and module contents that restrict movement of fresh air, smoke, and fire gases within the structure
- (3) Module components, especially shelves and module tops that restrict distribution of water discharged from sprinklers within the storage module
- (4) A module “envelope” consisting of the top and end panels of moveable ranges and the top, end, and back panels of fixed ranges that can hinder movement of heat, smoke, and fire gases from within the module and hinder penetration of extinguishing agent into the module
- (5) Module construction materials that can be either energy absorbing (metal) or energy generating (wood, plastics)
- (6) High fuel loading resulting in the possibility of fire duration, possibly threatening structural elements

Materials in storage can also have an impact upon fire development and the effectiveness of detection and suppression activities and equipment. Some of these characteristics include the following:

- (1) Packing density
- (2) Moisture content
- (3) Fuel type (cellulosic, plastic)

The tests that are the subject of this analysis were performed utilizing moving-aisle-type storage. The characteristics of the combustible contents of the shelving module were varied as discussed for the specific test.

Summary of Conclusions

This summary will list the conclusions drawn as a result of analysis of the specific General Services Administration/Factory Mutual test program and the tentative conclusions drawn by extrapolation of the test results beyond characteristics of the storage situation examined by the specific tests, as follows:

- (1) Analysis of Test Results
 - (a) There is a high probability that automatic sprinklers (including on/off sprinklers) installed on an ordinary hazard basis over a compact storage module

will prevent structural damage to building structural elements when structural elements are not enclosed partially or wholly by the storage module. (It is not possible to conclude whether or not sprinkler protection will adequately protect structural elements that are enclosed partially or wholly by the module.)

- (b) The relatively low rate of heat release observed in these fires will permit the use of 165°F (74°C) sprinklers without overtaxing water supplies.
 - (c) There is a high probability that the combined effects of automatic sprinklers and spatial separation will prevent fire spread across a 4-ft (1.2-m) wide aisle at the end of compact storage modules to the end of an adjacent module where sprinklers are installed on an ordinary hazard basis.
 - (d) There is a high probability that the fire will not spread between back-to-back shelves of the fixed ranges of adjacent modules when each shelf is backed by a sheet metal panel and the panels are separated by 1 in. (25 mm) or more.
 - (e) Test No. 3 produced a more severe fire than Test No. 2 because of the higher degree of openness and the more severe burning characteristics of the fuels in Test No. 3 as compared to Test No. 2. (It is not possible to separate the effect of openness from the effect of burning characteristics on the basis of this test series.)
 - (f) Manual overhaul of a fire in a compact storage module will be required to extinguish all combustion before total consumption of fuels not directly wetted by sprinkler discharge.
 - (g) Mechanical or effective natural draft smoke removal will be required to permit manual overhaul operations.
 - (h) The effect of test room humidity and the moisture content of the test materials could not be judged in these tests.
- (2) Extrapolation of Test Results
 - (a) Single-thickness metal dividers between back-to-back shelves within a movable carriage will reduce the rate of fire development. (It is not possible to conclude whether or not a single-thickness sheet metal divider between back-to-back shelves on a movable carriage will prevent fire spread between combustibles on those shelves.)
 - (b) Improved vertical openness as provided by louvered, perforated, or rolled bar module tops and shelves can improve the effectiveness of ceiling-mounted sprinklers.
 - (c) A combination of improved vertical openness, as provided by louvered or perforated module tops and shelves and decreased horizontal openness resulting from installation of longitudinal carriage dividers, can allow ceiling-mounted automatic sprinkler protection to limit flame damage to a portion of a storage module.
 - (d) The use of wooden structural framing and shelving can increase the rate and duration of burning and can also lead to earlier structural collapse of shelves than the use of steel framing and shelving.
 - (e) Chemical and physical characteristics of materials in storage will have a major impact upon the rate

of fire development and the fire duration experienced in compact storage modules.

- (f) The moisture content of a material in storage will affect its ease of ignition and the rate of subsequent flame spread over its surface.
- (g) A smoke detection system can be utilized to provide relatively early warning of a fire in a compact storage module if properly engineered to take into account ventilation conditions, and if it is recognized that the slow release of smoke from the module can lead to apparently delayed detection compared to a fire unconfined by a compact storage module.
- (h) It is highly unlikely that thermal detection would take place in time to permit manual fire fighting without self-contained breathing apparatus and without incurring serious visibility problems.
- (i) Given the difficulty of achieving Halon 1301 saturation of the compact storage module and the smoldering nature of fires in compact storage, Halon 1301 does not appear to be well suited for protection of materials in compact storage.
- (j) Limitation of the quantity of the material in a common enclosure can limit the extent of flame, heat, smoke, and fire gas damage to the materials.

Additional Testing

A series of limited and full-scale fire tests are depicted in Figure H.1(c) through Figure H.1(e) that would permit assessment of the validity of the tentative conclusions drawn concerning various module and protection system characteristics.

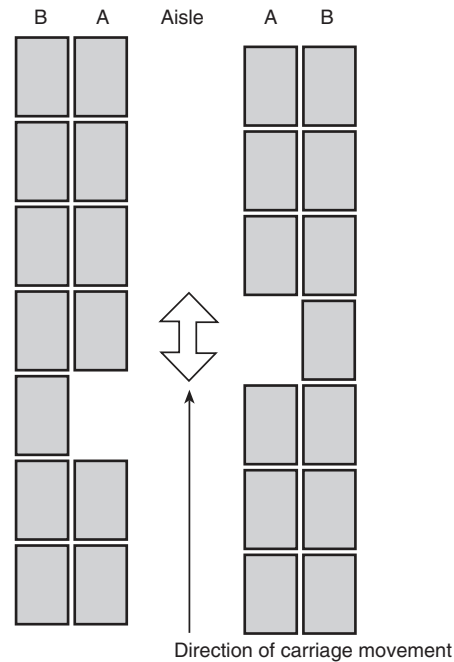

A — Movable carriages for individual shelf sections
B — Fixed range

FIGURE H.1(b) Moving Shelf Storage.

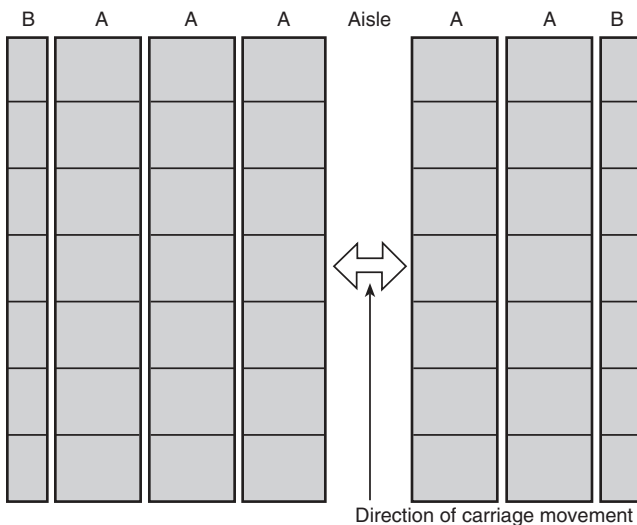

A — Movable carriages for range of shelving
B — Fixed range

FIGURE H.1(a) Moving Aisle Storage.

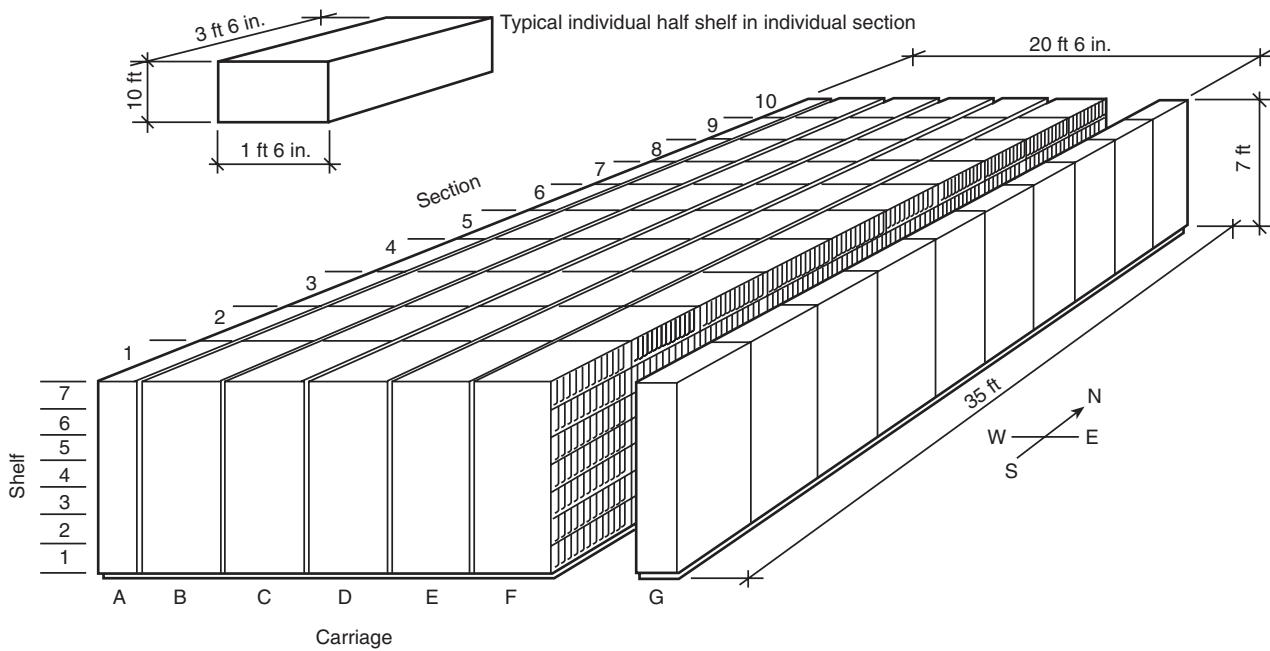

FIGURE H.1(c) Mobile Shelving Array Terminology and Dimensions.

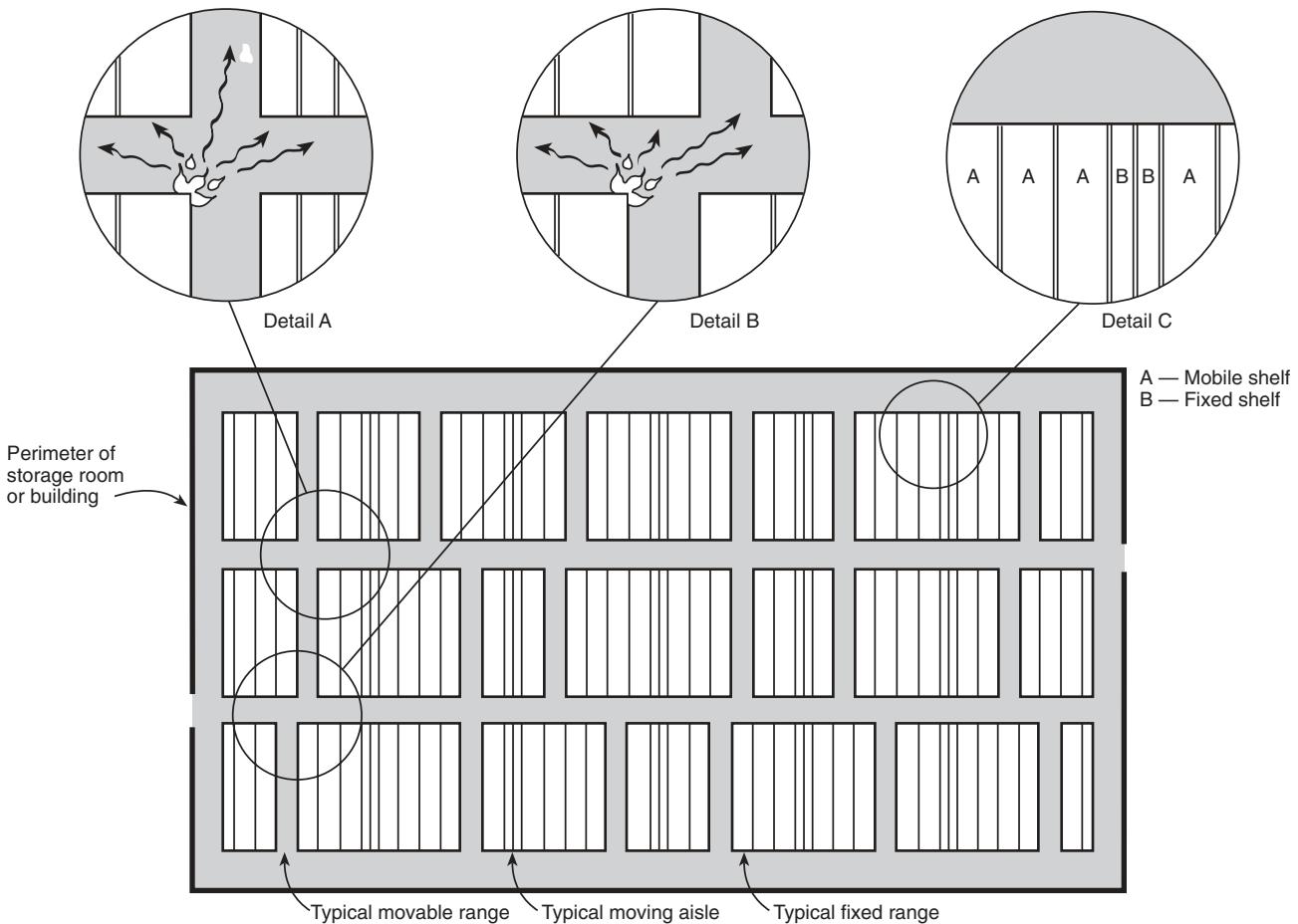
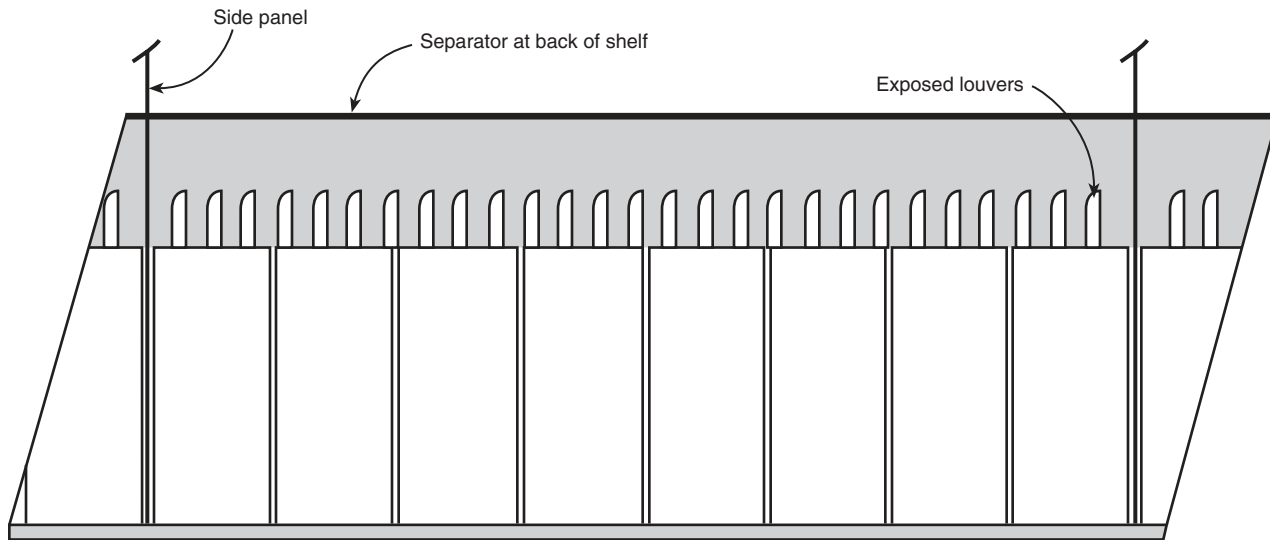
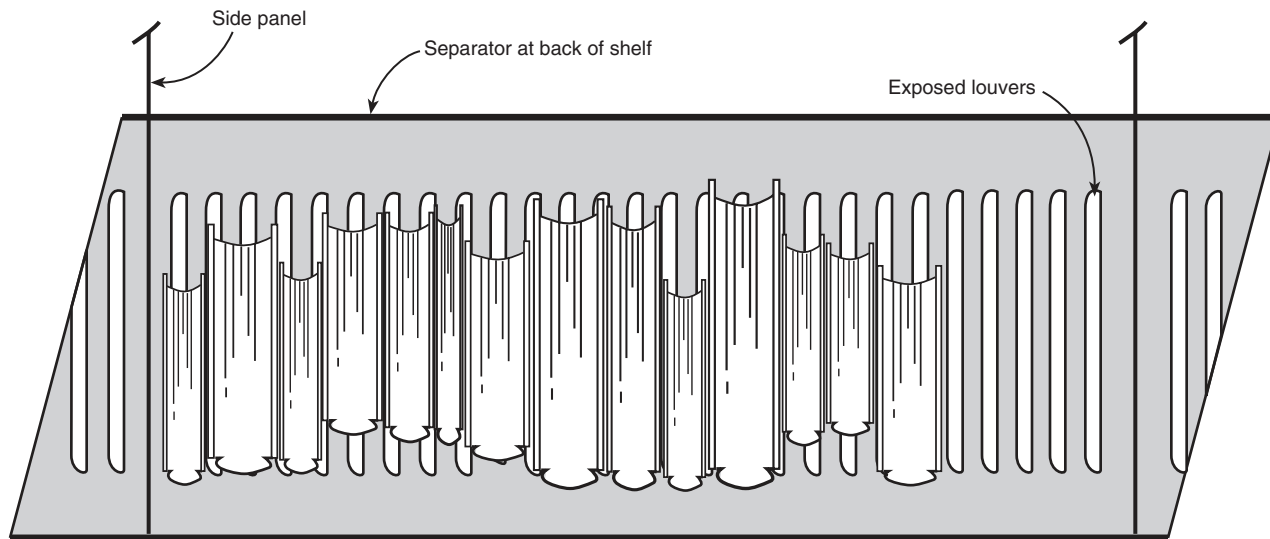

FIGURE H.1(d) Multiple Module Storage.



PLAN VIEW — archival boxes, 100% packing density



PLAN VIEW — library books, 80% packing density

FIGURE H.1(e) Potential Improvement in Vertical Openness.

Annex I Cultural Resource Property Protection Self-Inspection Checklist

This annex is not part of the requirements of this NFPA document but is included for informational purposes only.

I.1 Quarterly Cultural Resource Property Protection Self-Inspection Checklist. The checklist in Figure I.1 should be used as a reminder during the inspection. Items requiring corrective action should be noted and reported to the responsible manager. Section 1 through Section 5 of the checklist can be used by the individual conducting the inspection during a tour of the cultural resource property. Section 6 is an inspection of records that should be accomplished by the fire safety manager and/or the security manager.

I.1 Quarterly Cultural Resource Property Protection Self-Inspection Checklist				
	Yes	N/A	No	Responsible Manager
(1) All Floors (inspect from top floor to basement)				
Are exit routes unobstructed and free of combustibles? If no, what and where?				
Are fire exit and directional signs illuminated and visible? If no, where?				
Are emergency lights operating properly? If no, where?				
Are refuge areas identified? If no, where?				
Do emergency intercom devices operate properly? If no, where?				
Are areas under staircases free of combustibles? If no, what and where?				
Are self-closing fire doors unobstructed? If no, where?				
Are windows secured on the inside and free from cracks or broken panes? If no, where?				
Are fire extinguishers mounted and labeled? If no, where?				
Are fire extinguishers unobstructed? If no, what and where?				
Are fire extinguishers fully charged with the pin secured? If no, where?				
Do fire extinguishers have inspection tags indicating they have been inspected within the prior month? If no, where?				
Are manual fire alarm boxes (pull stations) unobstructed? If no, where?				
Are all sprinkler control valves in the open position? If no, where?				
Are all sprinkler control valves unobstructed? If no, what and where?				
Are standpipe hose outlets properly labeled? If no, where?				
Are standpipe hose outlets unobstructed? If no, what and where?				
Are first-aid kits stocked? If no, where?				
Are emergency response kits stocked? If no, what and where?				
Are electrical panels cool to the touch? If no, where?				
Are electrical panels unobstructed with 36 in. clearance? If no, what and where?				
Are all electrical panel circuits identified and labeled? If no, where?				
Are blanks installed in unused circuits in electrical panels? If no, where?				
© 2016 National Fire Protection Association				NFPA 909 (p. 1 of 4)

FIGURE I.1 Cultural Resource Property Protection Self-Inspection Checklist.

I.1 Quarterly Cultural Resource Property Protection Self-Inspection Checklist				
	Yes	N/A	No	Responsible Manager
Are power strips being used instead of extension cords and multiplug adaptors? If no, what and where?				
Are electrical cords in good condition and free of cuts or splices? If no, what and where?				
Are electrical plugs in good condition with the ground plug intact? If no, where?				
(2) Work Rooms and Storage Areas				
Are sprinkler heads unobstructed with 18 in. clearance from stored items? If no, what and where?				
Is stock storage neat and orderly? If no, where?				
Are supply closets and slop sink areas clean and orderly? If no, where?				
Are cleaning supplies and chemicals labeled, sealed, and stored in a secure area? If no, what and where?				
Are material safety data sheets for cleaning supplies and chemicals present and accessible? If no, what and where?				
Are gas cylinders chained and secured? If no, what and where?				
Are collection storage areas free of leaks, condensation, water stains, or standing water? If no, what and where?				
Are collection storage areas free of peeling paint, mold, pests, or unusual deposits of soot or particulate matter? If no, what and where?				
Are stocks of flammable liquids stored away from the building in proper flammable containers and cabinets? If no, what and where?				
Are quantities of flammable liquids in work rooms limited to a daily use amount? If no, what and where?				
Is trash accumulation limited to receptacles? If no, what and where?				
(3) Public Areas, Auditoriums, Classrooms, and Dining Areas				
Are furnishings and fixtures arranged to provide aisles with unobstructed access to emergency exits at all times? If no, where?				
(4) Kitchens				
Is cooking equipment clean and free of grease buildup? If no, where?				
Are fire extinguishers free of grease buildup? If no, where?				
Do range/fryer hood exhaust duct systems have a tag showing a cleaning date within the prior 3 months? If no, where?				
Do range/fryer hoods equipped with automatic fire suppression systems have a tag showing an inspection date within the prior 6 months? If no, where?				
(5) Exterior Inspection				
Do all emergency exits and fire escapes provide unobstructed passage to safe areas? If no, what and where?				
Do fire escapes appear to be in good condition? If no, where?				
Are fire lanes and access ways clear for emergency vehicles? If no, what and where?				

© 2016 National Fire Protection Association

NFPA 909 (p. 2 of 4)

FIGURE I.1 *Continued*

I.1 Quarterly Cultural Resource Property Protection Self-Inspection Checklist				
	Yes	N/A	No	Responsible Manager
Are fire hydrants and fire department connections unobstructed? If no, what and where?				
Are standpipe and sprinkler control valves secured in the open position? If no, where?				
Are grounds clear of accumulations of flammable materials? If no, what and where?				
Are designated smoking areas observed and equipped with noncombustible receptacles? If no, where?				
Do exterior doors have no more than 1/8 in. (3.2 mm) clearance between the door and frame? If no, where?				
Are exterior walls free from cracks or other damages? If no, where?				
Are exterior lights working properly? If no, where?				
Are surge arresters and surge protective devices in good condition? If no, where?				
Is shrubbery and vegetation around the building pruned or cut back? If no, where?				
Are fences and perimeter protection devices in good repair? If no, where?				
Are roof ladders secured to prevent unauthorized access? If no, where?				
Are skylights and roof hatches secured to prevent unauthorized access? If no, where?				
Are roof and ground drains unobstructed? If no, where?				
Are collection inventory records and insurance documents on-site with back-up copy off-site? Off-site location:				
Has the inventory been reviewed and updated within the last year? Date of last inventory:				
Have new acquisitions received within the prior 3 months been added to the inventory? If no, what?				
Have a vulnerability assessment and risk analysis been conducted? Date of last assessment:				
Has the emergency operations component of the protection plan been reviewed and updated within the last year? Date of last review:				
Have the emergency telephone numbers been verified within the last 3 months? Date last verified:				
Has the fire safety management component of the protection plan been reviewed and updated within the last year? Date of last update:				
Has the security component of the protection plan been reviewed and updated within the last year? Date of last update:				
Have all staff members received training in emergency response, fire safety, and security within the last year? Date of last training:				
Has an emergency response drill been conducted within the last year? Date of last drill:				
Have deficiencies noted during the drill been addressed? If no, what?				
© 2016 National Fire Protection Association				NFPA 909 (p. 3 of 4)

FIGURE I.1 *Continued*

I.1 Quarterly Cultural Resource Property Protection Self-Inspection Checklist				
	Yes	N/A	No	Responsible Manager
Are as-built plans, specifications, operations and maintenance manuals, and acceptance test reports for all protection systems and equipment on-site? If no, what is missing?				
Have protection equipment and systems been tested, inspected, and maintained within the last 3 months? Date of last test/inspection/maintenance:				
Has the local code enforcement official conducted a fire safety inspection during the last 12 months? Date of last inspection:				
Have deficiencies cited during the inspection been corrected? If no, what has not been corrected?				
Have reports been completed for any emergency, fire, or security incident during the last 3 months? If no, why?				
Have deficiencies cited in reports been corrected? If no, what has not been corrected?				
Do records indicate that fire extinguishers have current hydrostatic test dates? If no, how many and where?				
<p>Comments: _____</p> <p>Inspection made by: _____ Date: _____</p> <p>Title: _____</p> <p>Report reviewed by: _____ Date: _____</p> <p>Corrective action item: _____ Referred to: _____</p> <p>_____</p> <p>_____</p> <p>_____</p> <p>Corrective actions completed: _____ Date: _____</p> <p>Fire Safety Manager: _____ Security Manager: _____</p>				
© 2016 National Fire Protection Association				NFPA 909 (p. 4 of 4)

FIGURE I.1 *Continued*

Annex J Fire System Maintenance Checklists

This annex is not a part of the requirements of this NFPA document but is included for informational purposes only.

J.1 Introduction. All fire protection and fire safety systems need to be maintained to ensure their operational reliability. These checklists provide the user with an outline of what the contractor or maintenance person should be following. Those responsible for the cultural resource property's operation and safety are encouraged to use professionals to perform the tests, maintenance, and service of all fire protection systems and fire protection-related elements.

J.2 Maintenance of Automatic Sprinkler and Standpipe Systems. Each alarm, dry pipe, preaction, and deluge valve should have maintenance tags (annual, 5 year) attached for recording the inspector's initials, date, pressure readings, and confirmation on maintenance/inspections performed on the system. Checklists detailing maintenance should be kept by the office responsible for maintenance. All problems noted should be corrected before initialing the maintenance tag.

During any renovation or inspection of an automatic sprinkler system the following should be reported to the facility manager for correction:

- (1) Sprinklers that are damaged, blocked by storage, painted, or otherwise impaired. (Construction, occupancy

changes, and changes to heating lighting and air conditioning systems can require relocating, adding, or replacing sprinklers.)

- (2) Pipe hangers with mechanical injury and corrosion.
- (3) Pipes or fittings with signs of leakage or corrosion.

General Requirements for All Sprinkler and Standpipe Systems

- Annually, inspect water pressure and air pressure gauges to make sure they are within normal range. Investigate a loss of pressure of more than 10 percent. Record new pressure readings on the attached tag.
- Annually, inspect control valve labels to ensure they are accurate. Replace missing signs and re-label inaccurate signs.
- Annually, inspect fire department connections to make sure inlets are unobstructed, that the protective caps are in place, that they are conspicuously marked and accessible for the fire department, and that hose threads are in good condition.
- Annually, lubricate each valve stem and reseal to prevent leaks.
- Annually, close and reopen each post indicator and outside stem and yoke (OS&Y) valve.

(continues)

- Annually, inspect fire department connections before freezing weather. The connection should be drained through the ball drip from the check valve to assure it will not freeze.
- Every 5 years, replace the gaskets in check valves.
- Every 5 years, recalibrate and/or replace pressure gages, if necessary.
- Every 5 years conduct an interior corrosion inspection of system piping.
- Fifty years after installation, remove a representative sample of sprinklers (at least two per floor) and have them operationally tested at a testing laboratory. Based on tests, replace sprinklers if necessary. Test a sampling of the sprinklers every 10 years thereafter.
- Fifty years after installation, inspect the sprinkler system in at least five remote and low point locations to determine the degree of pipe corrosion. Where corrosion is found, have a fire protection engineer or sprinkler designer determine the hydraulic performance of the sprinkler system.

Wet Pipe and Antifreeze Systems

- Annually, open the inspector's test connection and test all alarms (water motor alarm and/or flow/pressure switch).
- Annually, before freezing weather, test the freezing point of antifreeze solutions with a hydrometer. Maintain the solution below the estimated minimum temperature.
- Annually, make sure wet pipe systems are properly protected from freezing.

Dry, Deluge, and Preaction Systems

- Annually, before freezing weather, operate the heating system in enclosures housing valves to ensure temperature can be maintained above 5.5 C (42°F).
- Annually, before freezing weather, open all low point drains to remove condensation and clean plugged or obstructed sprinklers.
- Annually, remove face plates of dry, deluge, and preaction valves and examine interior for corrosion and condition of gasket.
- Annually, trip test the dry pipe, deluge, or preaction valve. Ensure quick opening devices operate properly. Once the main valve trips, quickly close the control valve.
- Every 3 years, flush system with water. The system should be filled with water for 2 days before flushing to allow pipe scale and deposits to soften. Drain system and then flush. Flush cross mains first by attaching 50 mm (2 in.) fire hose at the end of the cross main. Flow water until clear. Also, record the residual water pressure from the supply side water pressure gauge. Remove and reinstall all pendant sprinklers after flushing is complete.
- Annually, activate preaction and deluge systems by operating the fire detection devices. Close the control valve to prohibit water from entering the system.
- Annually, lubricate air compressors on preaction and dry systems in accordance with manufacturer recommendations.
- Annually, test low air pressure alarm on preaction and dry systems. Close the water supply valve. Slowly release air from the system by slowly opening the inspectors test valve. Release enough pressure to sound the alarm. Avoid tripping the dry pipe valve.

(continues)

- Quarterly, determine dry pipe system priming water level by slowly opening the priming water level test valve. If only air escapes, close the test valve and add about one quart of water. Repeat the procedure until water comes out of the test valve.
- Annually, flow test open sprinklers on deluge sprinkler systems during warm weather.

J.3 Maintenance of Fire Detection and Alarm Systems. Fire detection and alarm systems should be tested at regular intervals. Test methods and frequency of tests should be in accordance with *NFPA 72*. Some of the tests that should be performed are as follows.

Alarms

- Annually, test audible devices, visible devices, and emergency voice/alarm communication equipment.

Control and Annunciation Units

- Quarterly for unmonitored systems and annually for monitored systems, test all functions, interfaced equipment, main and standby power supply, and fuses.

Batteries

- Annually, test the charger. Conduct a 30-minute discharge test semiannually for lead acid batteries and annually for nickel-cadmium batteries.

Alarm Initiating Devices

- Annually, test all smoke detectors, fire alarm boxes, and restorable heat detectors. Smoke detector sensitivity should be checked as detailed in *NFPA 72*.
- Other tests, depending on the type of fire alarm system installed, should be conducted as detailed in *NFPA 72*.

J.4 Maintenance of Fire Hose Stations. Where fire hose is allowed, hose stations should have monthly and annual (all-weather) maintenance tags attached for recording the inspector's initials, date, and confirmation on maintenance/inspections performed on the system. Checklists detailing maintenance should be kept by the office responsible for maintenance. All problems noted should be corrected before initialing maintenance tag.

- Inspect fire hose stations monthly. Hose stations should contain a minimum of 45 m (150 ft) of hose, hose nozzle, and hydrant wrench. Hose should not be damaged or show mildew. Hose needs to be neatly rolled or racked.
- Monthly test nozzles to confirm that they can be easily opened and closed.
- Rerack or rewind hose annually.

J.5 Maintenance of Fire Hydrants. Fire hydrants should have annual maintenance tags attached for recording the inspector's initials, date, and confirmation on maintenance/inspections performed on the system. Checklists detailing maintenance should be kept by the office responsible for maintenance. All problems noted should be corrected before initialing maintenance tag.

- Annually, inspect fire hydrants in the fall to ensure the following:
 - (1) Tightness of hydrant outlet
 - (2) No leaks in top of hydrant
 - (3) No cracks in hydrant barrel
 - (4) Hydrant drain is clear
 - (5) Turning nut is not worn down with rounded corners
 - (6) Undamaged nozzle threads
- Annually, lubricate operating nut, parking, and trust collars.
- Annually perform a flow test to check for proper hydrant operation and to test the available water supply in accordance with NFPA 291. Flow water from each hydrant.

J.6 Maintenance of Fire Pumps. Fire pumps should have weekly and annual maintenance tags attached for recording the inspector's initials, date, and confirmation on maintenance/inspections performed on the system. Water flow meters should have 5-year maintenance tags attached. Checklists detailing maintenance should be kept by the cultural resource property. All problems noted should be corrected before initialing the maintenance tag.

Weekly

- Close system valve to avoid pressurizing the automatic sprinkler system. Turn jockey pump off and gradually release pressure in the sprinkler system to confirm that low system pressure turns fire pump on. Run pump for 10 minutes. Check for excessive heat or water leakage at packing glands. At the end of the test, confirm that the fire pump and jockey pump controllers are on automatic and the pump supply and discharge valves and the sprinkler system valves are open.
- Record suction and discharge pressure on maintenance tag.

Annually

- Perform annual flow test in accordance with NFPA 20.
- Turn jockey pump off and gradually release pressure in the sprinkler system to confirm that low system pressure turns fire pump on.
- Confirm proper operation of remote annunciation for pump on and power supervision on fire alarm control unit.
- Close and open control valves to ensure proper operation. Also, confirm that tamper switches on control valves are operational.
- Lubricate motors and engines in accordance with manufacturer recommendations.

Every 5 Years

- Calibrate the water flow meter, if one is installed, during the annual flow test.

J.7 Maintenance of Water Storage Tanks Used for Fire Protection. Water storage tanks used for fire protection should have monthly, annual, and 5-year maintenance tags attached at the main control valve for recording the inspector's initials, date, and confirmation on maintenance/inspections performed on the system. Checklists detailing maintenance should be kept by the office responsible for maintenance. All problems noted should be corrected before initialing maintenance tag.

- Check water level in storage tanks monthly.
- Operate control valves monthly to assure they are properly arranged (generally open) and operational.
- Inspect storage tanks annually for the following:
 - (1) General condition of the tank, including loose scale, leaky seams or rivets, and paint
 - (2) Ladders on tanks for structural adequacy and the presence of rust
 - (3) The roof of storage tanks for structural stability and the presence of rust
 - (4) Sway bracing for elevated water storage tanks for structural adequacy and the presence of rust
- Conduct a flow test annually to make sure that equipment is performing properly, pipes are unobstructed, and appropriate valves are open. Perform in conjunction with fire hydrant annual tests (*See Section J.4*).
- Approximately every 5 years, thoroughly clean the interior and exterior of the tank and repaint. Temporary water supplies for fire protection need to be provided before the tank is drained.

J.8 Maintenance of Halon Systems. Halon systems should have monthly, annual, and 5-year maintenance tags attached to the halon cylinders for recording the inspector's initials, date, and confirmation on maintenance/inspections performed on the system. Checklists detailing maintenance should be kept by the office responsible for maintenance. All problems found should be corrected before initialing the maintenance tag. (Fire alarm functions should be maintained in accordance with Section J.1.) The use of halon is being phased out due to environmental concerns. However, existing systems are allowed to remain installed in the United States and to be maintained in operating condition.

Monthly

- Inspect the halon cylinders and piping for physical damage.
- Record the new pressure reading on the maintenance tag. Pressure needs to be within 10 percent of previous reading on the maintenance tag. Low readings require weighing the tank to confirm low pressure. Report confirmed low readings. Do not refill system.

Annually

- Weigh cylinders and determine if weight is within 5 percent of previous reading on the maintenance tag. Record pressure on maintenance tag. Report low readings. Do not refill system.
- Operate control valves and correct any problems found.
- Perform an operational test on system without discharging halon. (Remove the control heads from the halon cylinders and operate the fire detectors.) Correct any problems found.

Every 5 Years

- Replace rubber hoses.
- Perform a fan pressurization test in the room.

J.9 Maintenance of Emergency Generator and Emergency Lighting. Emergency generators should have weekly and annual maintenance tags attached for recording the inspector's initials, date, and confirmation of maintenance/inspections performed on the system. Checklists detailing maintenance should be kept by the office responsible for maintenance.

- (1) Operate emergency generators weekly. Correct potential operational problems.
- (2) Operate emergency generator under a simulated load biannually.
- (3) Lubricate motors and engines annually in accordance with manufacturer recommendations.
- (4) Perform an emergency lighting test biannually using the emergency generator. Fire pump(s), fire alarm systems, and electronic exit locking systems should be tested on emergency power concurrently.

Monthly

- Inspect the halon cylinders and piping for physical damage.
- Record the new pressure reading on the maintenance tag. Pressure needs to be within 10 percent of previous reading on the maintenance tag. Low readings require weighing the tank to confirm low pressure. Report confirmed low readings. Do not refill system.

Annually

- Weigh cylinders and determine if weight is within 5 percent of previous reading on the maintenance tag. Record pressure on maintenance tag. Report low readings. Do not refill system.
- Operate control valves and correct any problems found.
- Perform an operational test on system without discharging halon. (Remove the control heads from the halon cylinders and operate the fire detectors.) Correct any problems found.

Every 5 Years

- Replace rubber hoses.
- Perform a fan pressurization test in the room.

J.10 Maintenance of Water Spray Systems for Kitchens. Annually, inspect contracts to confirm water spray systems are being maintained in accordance with manufacturer recommendations, including the following:

- (1) The monthly inspection of systems is done by a company specializing in the maintenance of these systems.
- (2) Sprinkler heads are clean of grease.
- (3) Gas and electric power shut-off are tested.
- (4) Water-wash hood cleaning systems are operational.
- (5) Sprinklers need to be replaced in accordance with manufacturer recommendations.
- (6) Manual pull stations send a signal to the control room.
- (7) Sprinklers are of the correct temperature rating and located directly above grease producing equipment at the correct height.
- (8) Monthly and annual maintenance tags are attached for recording the inspector's initials, date, and confirmation on maintenance/inspections performed on the system. Checklists detailing maintenance should be kept by the responsible office.

J.11 Maintenance of Dry Chemical Systems. Annually, inspect maintenance contracts to ensure dry chemical systems are

being maintained in accordance with manufacturer recommendations, including the following:

- (1) The monthly inspection of a system is being done by a company specializing in the maintenance of these systems.
- (2) Nozzles are clean of grease.
- (3) Gas and electric power shut-off are tested.
- (4) Water-wash hood cleaning systems are operational.
- (5) Fusible links are replaced annually.
- (6) Manual pull stations send a signal to the control room.
- (7) Fusible links are of the correct temperature rating.
- (8) Nozzles are located directly above grease producing equipment at the correct height.
- (9) Pressure on gauge is adequate.
- (10) Manual release stations are operational and accessible.
- (11) Monthly and annual maintenance tags are attached for recording the inspector's initials, date, and confirmation on maintenance/inspections performed on the system. Checklists detailing maintenance should be kept by the responsible office.

J.12 Maintenance of Fire Doors and Fire Dampers. Personnel responsible for maintenance should have location maps of fire doors and fire dampers and checklists detailing maintenance on each door or damper.

Fire Doors

- Annually, inspect fire doors for the following items. Correct any problems found.
 - (1) Door envelope does not have punctures or broken seams.
 - (2) Self-closer is intact and allows door to latch closed.
 - (3) If a sliding door, chains and cables operate smoothly over all pulleys and guides.
 - (4) Doors have not been modified in the field (e.g., by the installation of louvers).
 - (5) Coordinators are securely attached and adjusted properly.
 - (6) Clearances around the door do not exceed the following:
 - (a) Between door and frame — 3.2 mm ($\frac{1}{8}$ in.)
 - (b) Between meeting edges of doors — 3.2 mm ($\frac{1}{8}$ in.)
 - (c) Between bottom of door and raised sill — 9.5 mm ($\frac{3}{8}$ in.)
 - (d) Between bottom of door and floor (no sill) — 19.0 mm ($\frac{3}{4}$ in.)
 - Annually, test doors normally held open by automatic closing devices to confirm proper operation. Sliding doors need to be allowed to close completely to check the operation of the guides and rollers. Correct any problems found.
 - Annually, lubricate guides and bearings.
- #### Fire Dampers
- Annually, test fire dampers to ensure hinges and other moving parts operate properly. Remove fusible links, operate damper, and check latch (if provided). It is desirable to operate dampers with normal system airflow to ensure that they are not held open by the air stream. Correct any problems found.
 - Annually, lubricate moving parts of fire damper. Note that smoke dampers should be tested with the operation of fire detectors in accordance with Section J.3.

J.13 Maintenance of Stair Pressurization and Smoke Venting Systems. Fans used for stairwell pressurization and smoke venting should have annual maintenance tags attached for recording the inspector's initials, date, and confirmation on maintenance/inspections performed on the system. Checklists detailing maintenance should be kept by the office responsible for maintenance.

- Annually, perform an air pressure test in stairwells having pressurization fans to make sure all system parts and controls are operational, and design air pressures (not to exceed NFPA 101 requirements) are obtained.
- Annually lubricate fan motors in accordance with manufacturer recommendations.

J.14 Maintenance of Portable Fire Extinguishers. Each extinguisher needs to have an inspection tag.

Inspect extinguishers monthly. An extinguisher inspection includes ensuring extinguishers are fully charged, in their designated locations, physically undamaged, not tampered with, not obstructed, and that the hydrostatic test is up to date (see Table J.14). The inspector should initial the inspection tag after the extinguisher is found in good working order.

- (1) Report obstructed or out-of-place extinguishers to the building manager.
- (2) Replace any extinguisher that is physically damaged or that has a broken or missing tamper indicator (plastic seal around the handle).
- (3) Replace any extinguisher on which the gauge indicates "recharge" or, in the case of carbon dioxide extinguishers, when there is a weight loss of 10 percent or more (the weight is listed on the label of the extinguisher). For example, if the label indicates 15.2 kg (33½ lb), replace the extinguisher when the weight goes below 14 kg (31 lb). The weight should be checked semiannually.
- (4) Replace any extinguisher requiring a hydrostatic test in accordance with the dates listed below. Each extinguisher is marked with the date of the last hydrostatic test (e.g., 1/26/80 or 1@80). Look for the most recent date and calculate when the extinguisher needs to be tested again. For example, a carbon dioxide extinguisher dated 1@80 should be retested in January 1985. (When an extinguisher needs to be replaced, use a spare extinguisher of the same type and at least equal rating as the one being replaced.)

Table J.14 Extinguisher Hydrostatic Test Periods.

Extinguisher Types	Hydrostatic Test Period
Dry chemical	12 years
Carbon dioxide	5 years
Stored water pressure	5 years
Halon	12 years

J.15 Maintenance of Lightning Protection Systems. Those responsible for maintenance/inspection should have detailed drawings of lightning protection systems and checklists detailing maintenance.

- Annually, inspect system for mechanical damage.
- Annually, test all connections for electrical resistance. If resistance to ground is more than 5 ohms, make necessary changes to reduce it to 5 ohms or less.

Annex K Salvage of Water-Damaged Library Materials

This annex is not a part of the requirements of this NFPA document but is included for informational purposes only.

K.1 The following material is extracted from *Procedures for Salvage of Water-Damaged Library Materials* by Peter Waters, Restoration Officer, Library of Congress, 1975 (an LC Publication on Conservation of Library Materials). The reader will find additional references on this topic in Section N.2.

Assessment of Damage and Planning for Salvage.

Weather is the critical factor in determining what course to take after any flood or fire in which museum, archival, or library materials are damaged. When it is hot and humid, salvage must be initiated with a minimum of delay to prevent or control the growth of mold. When the weather is cold, more time can be taken to plan salvage operations and experiment with various drying procedures.

The first step is to establish the character and degree of damage. Once an accurate assessment of the damage has been made, firm priorities and plans for salvaging the damaged materials can be drawn up. These plans must include a determination of the special facilities and equipment required. Overcautious, unrealistic, or inadequate appraisals of damage can result in the loss of valuable materials. Speed is of the utmost importance, but careful planning is equally essential in the salvage effort.

Where water damage has resulted from fire fighting measures, cooperation with the fire marshal is vital for a realistic appraisal of the feasibility of salvage efforts. Fire marshals and safety personnel will decide when a damaged building is safe to enter. In some cases, areas involved in the fire may require a week or longer before they are cool enough to be entered. Occasionally, parts of a collection may be identified early in the salvage planning effort as being especially vulnerable to destruction unless they receive attention within a few hours after the fire has abated. If the fire marshal appreciates such needs, he may be able to provide means of access to the area even when other parts of the building remain hazardous.

Once all entrances and aisles are cleared, the most important collections, including rare materials and those of permanent research value, should be salvaged first, unless other materials would be more severely damaged by prolonged immersion in water. Examples of the latter are books printed on paper of types widely produced between 1880 and 1946, now brittle or semi-brittle. However, materials in this category that can be replaced should be left until last.

Salvage operations must be planned so that the environment of flooded areas can be stabilized and controlled both before and during the removal of the damaged materials. In warm, humid weather, mold growth may be expected to appear in a water-damaged area within 48 hours. In any weather, mold will appear within 48 hours in unventilated areas made warm and humid by recent fire in adjacent parts of the building. For this reason, every effort should be made to reduce high temperatures and vent the areas as soon as the water has receded or been pumped out. Water-soaked materials must be kept as cool as possible by good air circulation until they can be stabilized. To leave such materials more than 48 hours in temperatures above 70°F (21°C) and humidity above 70 percent will almost certainly result in heavy mold growth and lead to high restoration costs.

Damaged most by these conditions are volumes printed on coated stock and such highly proteinaceous materials as leather and vellum bindings. Starch-impregnated cloths, glues, adhesives, and starch pastes are affected to a lesser degree. As long as books are tightly shelved, mold will develop only on the outer edges of the bindings. Thus no attempt should be made in these conditions to separate books and fan them open. Archival files packed closely together on the shelves in cardboard boxes or in metal file cabinets are the least affected.

As a general rule, damp books located in warm and humid areas without ventilation will be subject to rapid mold growth. Archival files that have not been disturbed will not be attacked as quickly by mold. Very wet materials, or those still under water, will not develop mold. As they begin to dry after removal from the water, however, both the bindings and the edges of books will be quickly attacked by mold, especially when in warm, unventilated areas. A different problem exists for books printed on coated stock, since if they are allowed to dry in this condition, the leaves will be permanently fused together.

Summary of Emergency Procedures

- (1) It is imperative to seek the advice and help of trained conservators with experience in salvaging water-damaged materials as soon as possible. The Library of Congress is an excellent information source for technical advice where needed. Contact: Preservation Office, Library of Congress, Washington, DC, Telephone (202) 707-5212. Information about emergency preparedness, response, and recovery is available online from the Library of Congress at <http://www.loc.gov/preserv/emergprep/prepare.html>, and from the website Conservation Online at <http://palimpsest.stanford.edu/bytopic/disasters/>. A list of leaflets on emergency management and salvage can be downloaded from the Northeast Document Conservation Center at <http://www.nedcc.org/resources/leaflets.list.php>.
- (2) Turn off heat and create free circulation of air.
- (3) Keep fans and air conditioning on at night, except when a fungicidal fogging operation is in process, because a constant flow of air is necessary to reduce the threat of mold.
- (4) Brief each worker carefully before salvage operations begin, giving full information on the dangers of proceeding except as directed. Emphasize the seriousness of timing and the priorities and aims of the whole operation. Instruct workers on means of recognizing manuscripts, materials with water-soluble components,

- leather and vellum bindings, materials printed on coated paper stock, and photographic materials.
- (5) Do not allow workers to attempt restoration of any items on site. (This was a common error in the first ten days after the Florence flood, when rare and valuable leather- and vellum-bound volumes were subjected to scrubbing and processing to remove mud. This resulted in driving mud into the interstices of leather, vellum, cloth, and paper, caused extensive damage to the volumes, and made the later work of restoration more difficult, time consuming, and extremely costly.)
- (6) Carry out all cleaning operations, whether outside the building or in controlled environment rooms, by washing gently with fresh, cold running water and soft cellulose sponges to aid in the release of mud and filth. Use sponges with a dabbing motion; do not rub. These instructions do not apply to materials with water-soluble components. Such materials should be frozen as quickly as possible.
- (7) Do not attempt to open a wet book. (Wet paper is very weak and will tear at a touch.) Hold a book firmly closed when cleaning, especially when washing or sponging. A closed book is highly resistant to impregnation and damage.
- (8) Do not attempt to separate single-sheet materials unless they are supported on polyester film or fabric.
- (9) Do not attempt to remove all mud by sponging. Mud is best removed from clothes when dry; this is also true of library materials.
- (10) Do not remove covers from books, as they will help to support the books during drying. When partially dry, books may be hung over nylon lines to finish drying. Do not hang books from lines while they are very wet because the weight will cause damage to the inside folds of the sections.
- (11) Do not press books and documents mechanically when they are water soaked. This can force mud into the paper and subject the materials to stresses that will damage their structures.
- (12) Use soft pencils for making notes on slips of paper but do not attempt to write on wet paper or other artifacts.
- (13) Clean, white blotter paper, white paper towels, strong toilet paper, and unprinted newsprint paper may be used for interleaving in the drying process. When nothing better is available, all but the color sections of printed newspapers may be used. Great care must be taken to avoid rubbing the inked surface of the newspaper over the material being dried; otherwise some offsetting of the ink may occur.
- (14) Under no circumstances should newly dried materials be packed in boxes and left without attention for more than a few days.
- (15) Do not use bleaches, detergents, water-soluble fungicides, wire staples, paper or bulldog clips, adhesive tape, or adhesives of any kind. Never use felt-tipped fiber or ballpoint pens or any marking device on wet paper. Never use colored blotting paper or colored paper of any kind to dry books and other documents.

Annex L Factory Mutual Engineering Division Laboratory Report

This annex is not a part of the requirements of this NFPA document but is included for informational purposes only.

L.1 This report is by P. E. Cotton, 14000/Res., December 21, 1959.

E. W. Cousins, Chief Research Engineer, and J. M. Rhodes, Director, Engineering and Laboratories, of the Factory Mutual Engineering Division.

Fire Tests of Library Book Stacks.

Consideration of library fire protection usually brings out two questions. First, would fire be expected to spread in a book stack? And second, if so, will automatic sprinklers keep the damage to a minimum? Two tests were made to show the answers. In both cases it was emphatically, yes.

The stack used in the tests is illustrated by Figure L.1(a), Figure L.1(b), and Figure L.1(c). It is a segment of a typical library stack, consisting of a steel structure supporting steel shelves that hold discarded library books. This structure was purchased from and erected by a manufacturer of library equipment. In the plan, the segment contains four ranges (lines of shelving) 12 ft (3.72 m) long facing on two aisles 4½ ft (1.4 m) on centers. Thus, the area occupied is 9 ft (2.79 m) wide by 12 ft (3.72 m) long. In elevation there are four tiers or stories, each 7½ ft (2.3 m) high, making a total height of 30 ft (9.3 m).

Test 1 — With Standard Automatic Sprinklers.

For the first fire test, standard automatic sprinklers were installed in both aisles in all four tiers of the stack. Since the sprinklers were spaced the maximum practical distance apart in the aisles [15 ft (4.6 m)], platforms were provided at each end of the stack to extend its effective length insofar as the sprinklers were concerned.

The fire was started in a small quantity of paper contained in a wooden book cart arranged as shown in Figure L.1(d).

Its location in one aisle of the lowest tier of the stack is illustrated in Figure L.1(e) through Figure L.1(h), which also show the fire growth, the action of the sprinklers, and the limitation of damage.

In this test, one sprinkler opened in the second tier at 3 minutes, 43 seconds after the fire was lighted and one sprinkler opened in the first tier 7 minutes, 53 seconds after the start. The sprinkler discharge stopped the spread of fire in the books almost immediately and gradually extinguished the fire.

There was fire damage to books in 10 percent of the storage space of the stack [see Figure L.1(i)], and this damage would be repairable for practically all of the books involved. Books in an additional 27 percent of the storage space of the test segment were wet in varying degrees ranging from dampness to soaking. All books so involved would be repairable by drying. Nine 3 ft (0.93 m) long shelf sections were deformed by heating, although the structural members of the stack were unharmed except for paint damage.

Test 2 — No Automatic Sprinkler System.

After replacing all fire- and water-damaged books and shelving following the first test, a second test was made using the same method of ignition as in the first test.

The spread of fire upward through the four tiers of the book stack is described best by Figure L.1(j) through Figure L.1(m). Added to this are the visual observations that books in the second tier began burning at approximately ¾ minutes, in the third tier at 7½ minutes, and in the fourth tier at 9 minutes. By 10 minutes, there was intense fire in all areas of the book stacks except at the lower shelves of the first tier in the aisle not containing the ignition source. A 1 in. (25 mm) hose line was used to attack the fire at 10 minutes, 23 seconds, followed by a 2½ in. (63 mm) hose line at 10 minutes, 40 seconds since the first hose stream was only slightly effective. Together, these hose streams controlled and essentially extinguished the fire, although smoldering continued for hours afterward.

Some indication of the extent of the damage to the books and stacks is given by the photographs in Figure L.1(n) through Figure L.1(p). Quantitatively, 89 percent of the books were charred deeply or completely destroyed, 2½ percent were scorched, and the remaining 8½ percent were soaked.

Approximately three-fourths of the shelving was irreparably damaged. Some of the structural elements were visibly deformed [see Figure L.1(q)]; others would not be safely reusable for live loads. These observations indicate that complete collapse of the structure was imminent when hose streams were applied. Figure L.1(r) gives a comparison of temperatures of various points in the structure for both tests. [See Figure L.1(s) for summary information].

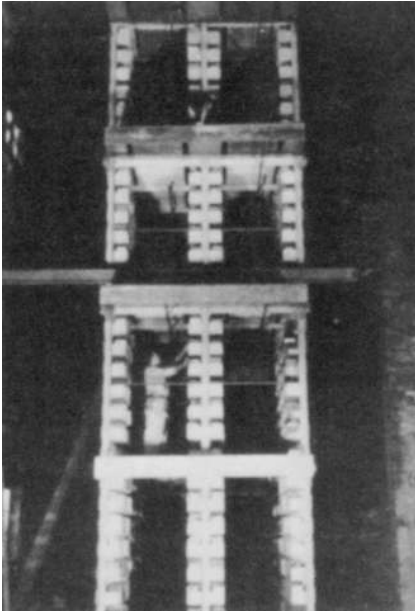

FIGURE L.1(a) General View of Four-Tier Book Stack Loaded With 11,200 Books.



FIGURE L.1(c) General View of Books in the First and Second Tiers Before Tests.



FIGURE L.1(b) Illustration of Structural Elements of Stack; Note One Sprinkler Position.



FIGURE L.1(d) Wood Book Cart Before Being Placed in Aisle of First Tier. (After placement, books were put on top shelf of book cart. The fire was started with an ordinary match by igniting the crumpled piece of paper between the two cartons on the bottom shelf of the cart.)

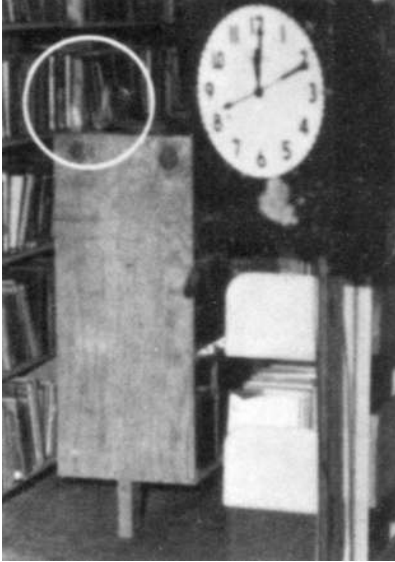

FIGURE L.1(e) One Minute, 10 Seconds; Flame Showing Above Book Cart; Sprinklers Not Yet Operating.



FIGURE L.1(g) Eight Minutes, 3 Seconds; Two Sprinklers Operating; Fire in Stack Under Control.



FIGURE L.1(f) Three Minutes, 25 Seconds; Active Burning in First Tier; Sprinklers Not Yet Operating.



FIGURE L.1(h) After Fire Extinguishment by Sprinklers; Fire Damage to Books in Only 10 Percent of Space.



FIGURE L.1(i) Close-up of Extent of Fire Damage After Test 1 with Automatic Sprinklers. (Note limited area of fire damage.)



FIGURE L.1(k) After Approximately 3 Minutes; Active Burning in First Tier; No Sprinklers.

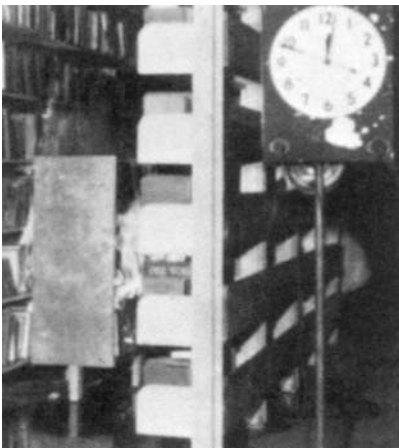

FIGURE L.1(j) One Minute, 48 Seconds; Books in Stack Ignited; No Sprinklers.

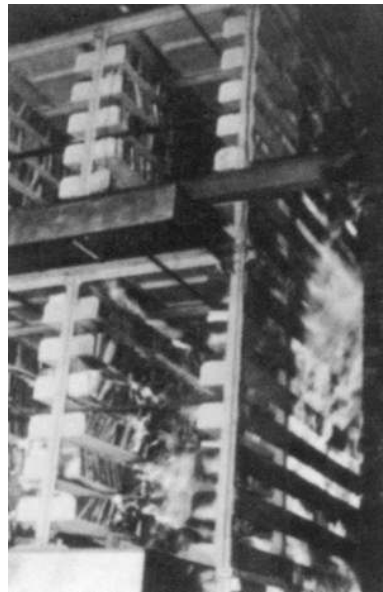

FIGURE L.1(l) After Approximately 7½ Minutes, Fire Involved Second and Third Tiers.

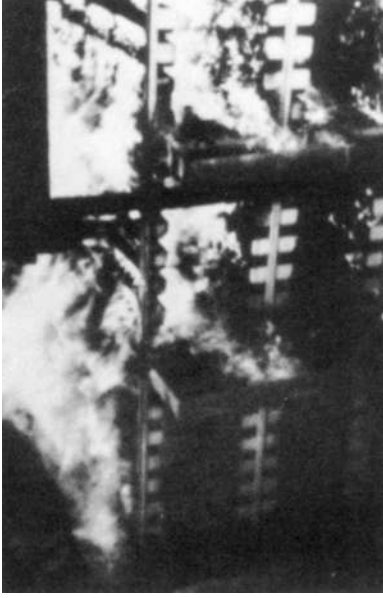

FIGURE L.1(m) After About 9½ Minutes, Flame Spread to Top Tier and Across Aisles on Lower Tiers.

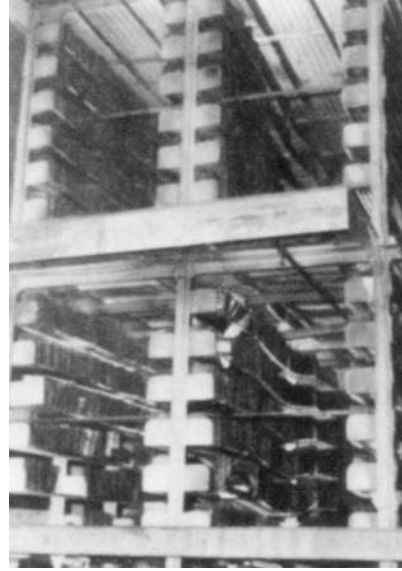

FIGURE L.1(o) General View of Third and Fourth Tiers; All Exposed Book Surfaces Charred.

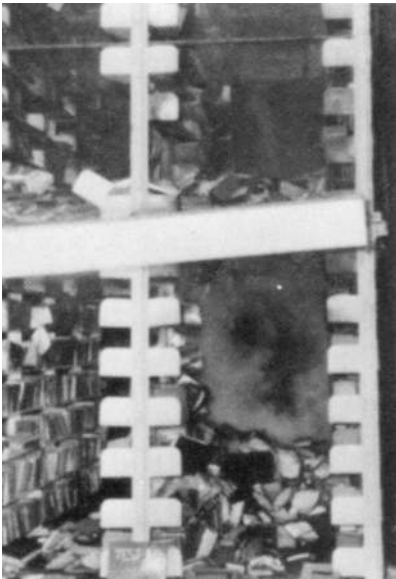

FIGURE L.1(n) General View of First and Second Tiers After Test 2; No Sprinklers.

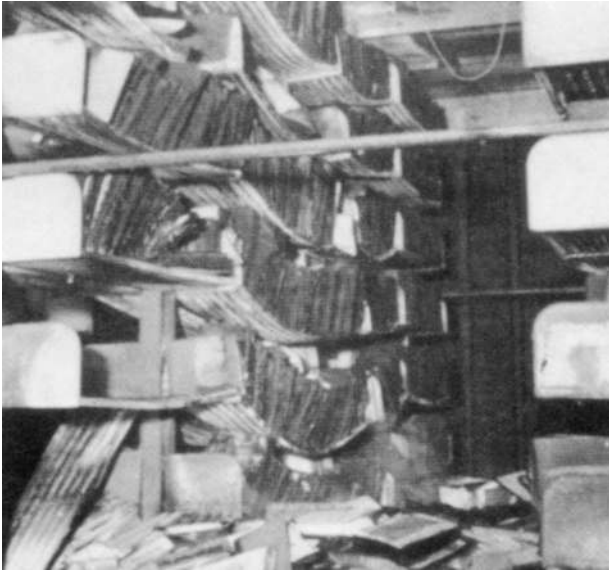

FIGURE L.1(p) Extent of Damage to Shelving After Test 2 on Second Tier, Right Aisle; No Sprinklers. (Note severe charring of books and collapse of shelving.)

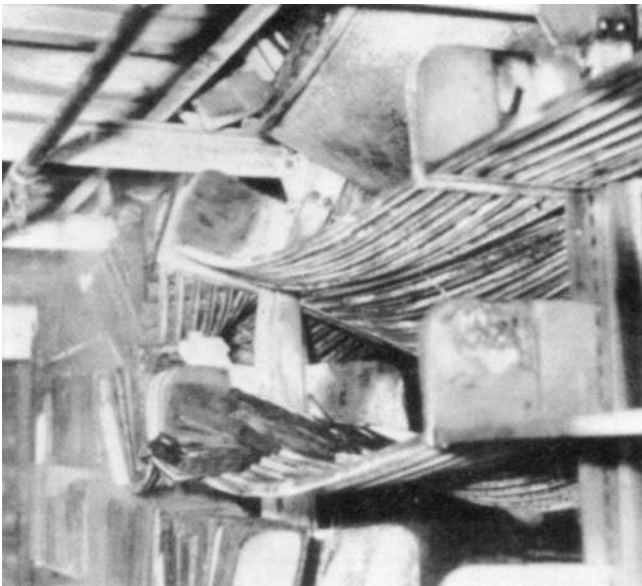

FIGURE L.1(q) View of First Tier, Left Aisle After Test 2; No Sprinklers. [The temperatures reached 1500°F (780°C) in each recorded location, whereas in Test 1 (with sprinklers) temperatures did not go above 500°F (260°C). Note failure of column (center of photo).]

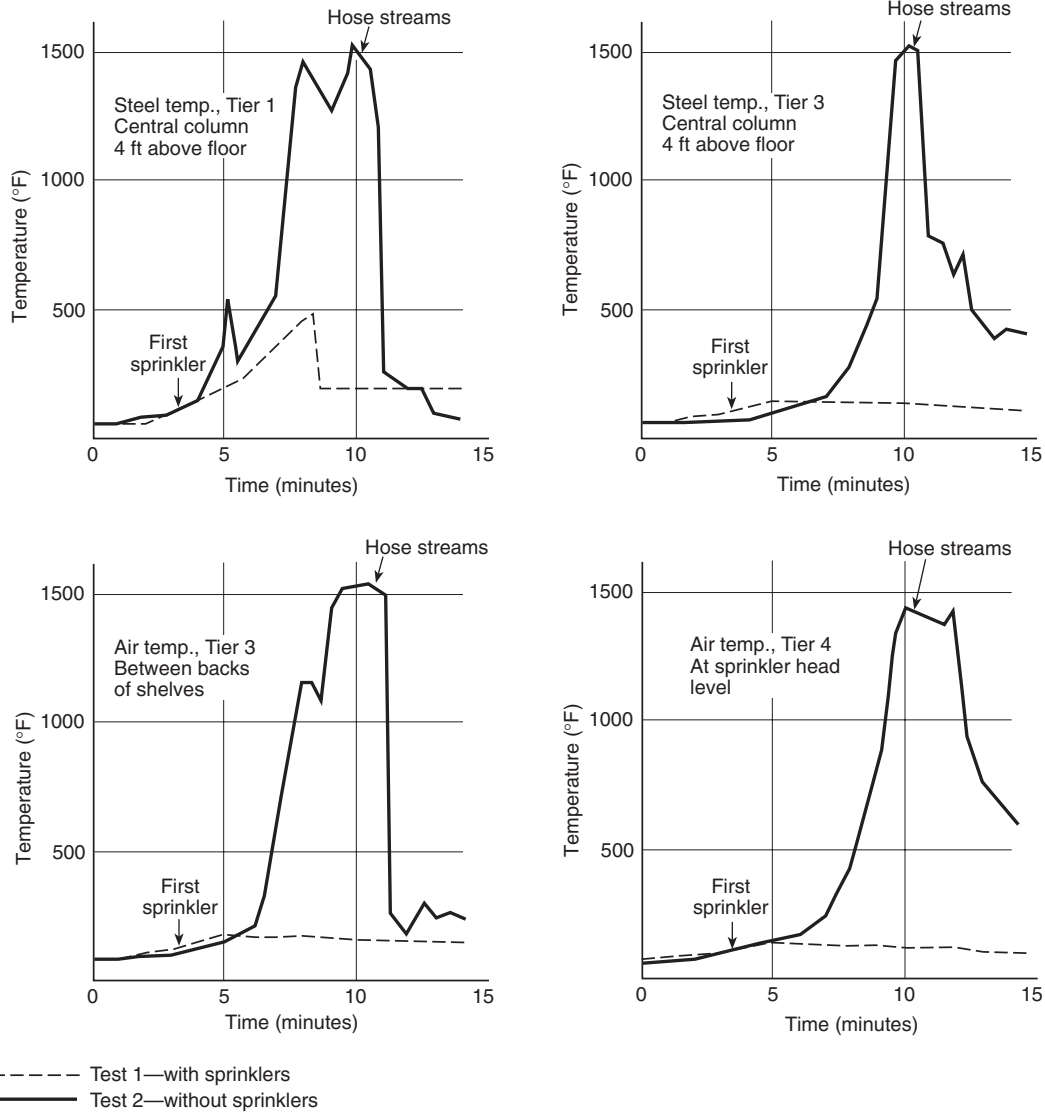

FIGURE L.1(r) Temperatures at Various Locations in Book Stacks.

Book Stack		Books	
Size:	9 ft wide; 12 ft long; 30 ft high (four 7½ ft high tiers)	Average:	25 per shelf; 175 per compartment; 700 per single range; 2800 per tier; 11,200 total
Book storage:	Four ranges of four compartments each in each tier	Approximate average weight per book:	1 lb dry; 2½ lbs soaking wet
Shelves:	Seven shelves in each compartment; all U-bar type except floor shelf, which is solid. Shelves are 3 ft long by 8 in. deep; spaced 1 ft apart vertically; except at floor and ceiling, where spacing is 15 in. 112 shelves per tier; 448 shelves total	Moisture content of books:	5 percent to 9 percent
Aisles:	3 ft wide; two 3 in. slots plus 30 in. walkway		
Weight of structure:	7000 lbs		

Book Cart and Contents	
<p>Book cart [shown in Figure M.1(d)] was made of wood (moisture content: 7 percent) and was 15 in. wide, 42 in. long, and 36 in. high. During the tests, 120 books were placed on the two top shelves (fully loaded), and the bottom shelf contained two open-top cardboard cartons (12 by 12 by 8 in.). Each carton contained two crumpled wrapping papers that were 3 ft by 3 ft each and between cartons was crumpled wrapping paper 1½ ft by 3 ft. The weight of the cartons and paper was 2 lbs; the weight of the book cart empty was 57 lbs. The test engineers considered this book cart fire “a modest local ignition source” for these library tests.</p>	

Sprinkler Protection	
<p>The sprinklers used were 160° standard sprinklers, pendent mounted, on 4½ ft by 15 ft spacing staggered vertically and horizontally. There were sprinklers in all tiers and all aisles of the test library book stack setup.</p> <p>Sprinkler deflectors were located 10 in. below the ceiling and 6 in. off center to allow for fluorescent lighting in actual library installations.</p> <p>The pressures were designed so that the static pressure at the end sprinkler was 5 psi on the fourth tier, 14¾ psi on the first tier, 11½ psi on the second tier, and 8¾ psi on the third tier.</p> <p>The approximate discharge per sprinkler was 22 gallons per minute (gpm) on the first tier, 19 gpm on the second tier, 16 gpm on the third tier, and 13 gpm on the fourth tier.</p>	

FIGURE L.1(s) Summary of Contents Structural Information.

Annex M Measuring the Impact of Fire Extinguisher Agents on Cultural Resource Materials

This annex is not a part of the requirements of this NFPA document but is included for informational purposes only.

M.1 General. In February 2010, the Fire Protection Research Foundation published a report titled “Measuring the Impact of Fire Extinguisher Agents on Cultural Resource Materials,” prepared by Hughes Associates, Inc., to develop protocols for testing the effects of extinguishing agents used in portable fire extinguishers on materials found in cultural resource collections. The report contains valuable information on work that has been done on the topic and a standard set of protocols that can be used in the future to test the effects of extinguishing agents on cultural resource collections.

The report is available to download, at no charge, at the NFPA 909 document information page on the NFPA website: <http://www.nfpa.org/909>.

The report executive summary is provided in Section M.2.

M.2 Executive Summary. Portable fire extinguishers and their associated fire extinguishing agents play an important role in reducing the impact of fire on cultural resource collections. A fire that can be extinguished with a portable extinguisher in its incipient stage will not grow to threaten adjacent materials. While conservators are well versed in the effects of moisture and water on collections, little data is available on the effects of other non-water based extinguishing agents. To fully evaluate

the appropriateness of an extinguisher, its extinguishing effectiveness should be compared to the potential collateral damage to collection materials from the agent and its thermal decomposition products. Such contact with collection materials can occur by overspray during fire-fighting efforts or the direct spraying of collection materials in an act of vandalism.

This project is intended to quantify the impact of discharging portable fire extinguisher agents on cultural resource materials. The results can then be used by the NFPA Technical Committee on Cultural Resources (NFPA 909 and NFPA 914) to provide users with guidance on extinguisher selection. Phase I of the project included a comprehensive literature review and the development of prototype specifications and procedures to test the effects of extinguishers. In an anticipated Phase II, the test specifications would be validated and a final test specification produced. The results of Phase I are presented in this report.

In order to understand extinguisher agents, a detailed review of portable fire extinguishers was performed. The characteristics of multi-purpose (ABC) dry chemical, carbon dioxide, clean agent halocarbon, and water mist extinguishers are documented. Both agent and collection material characteristics were identified. While the effect of water/moisture on materials is well known, the effects of other agents are not well known. This supports the need for the testing proposed in this project.

In order to establish the fire protocol in the test specification, early stage fire scenarios were assessed. A fire loss review of museums, libraries, and other heritage and cultural buildings revealed that fires are most likely to involve ordinary, solid combustibles. A fire size on the order of 350 kW using a standardized wood crib was selected as a representative fire threat. Test and measurement techniques were identified. Tradeoffs were analyzed in terms of a detailed, scientific approach compared to ad hoc discharge tests. A middle ground was adopted, with the goal to provide a cost-effective, repeatable test method using actual collection materials.

Three basic tests were recommended, including physical impact tests, non-fire exposure tests, and fire exposure tests. A prototype test specification was developed based on material and agent variables. Anticipated agent effects were considered in specifying the test set up, procedures, and instrumentation. In anticipation of data that will be derived in testing, a spreadsheet was created that provides a preliminary, generic description of collection materials and known environmental impacts. The categories are generally aligned with specialty areas of conservation and collections.

Annex N Informational References

N.1 Referenced Publications. The following documents or portions thereof are referenced within this code for informational purposes only and are thus not part of the requirements of this document unless also listed in Chapter 2.

N.1.1 NFPA Publications. National Fire Protection Association, 1 Batterymarch Park, Quincy, MA 02169-7471.

NFPA 1, *Fire Code*, 2015 edition.

NFPA 10, *Standard for Portable Fire Extinguishers*, 2013 edition.

NFPA 11, *Standard for Low-, Medium-, and High-Expansion Foam*, 2016 edition.

NFPA 12, *Standard on Carbon Dioxide Extinguishing Systems*, 2015 edition.

NFPA 12A, *Standard on Halon 1301 Fire Extinguishing Systems*, 2015 edition.

NFPA 13, *Standard for the Installation of Sprinkler Systems*, 2016 edition.

NFPA 14, *Standard for the Installation of Standpipe and Hose Systems*, 2016 edition.

NFPA 17, *Standard for Dry Chemical Extinguishing Systems*, 2017 edition.

NFPA 17A, *Standard for Wet Chemical Extinguishing Systems*, 2017 edition.

NFPA 20, *Standard for the Installation of Stationary Pumps for Fire Protection*, 2016 edition.

NFPA 22, *Standard for Water Tanks for Private Fire Protection*, 2013 edition.

NFPA 25, *Standard for the Inspection, Testing, and Maintenance of Water-Based Fire Protection Systems*, 2017 edition.

NFPA 40, *Standard for the Storage and Handling of Cellulose Nitrate Film*, 2016 edition.

NFPA 51B, *Standard for Fire Prevention During Welding, Cutting, and Other Hot Work*, 2014 edition.

NFPA 70B, *Recommended Practice for Electrical Equipment Maintenance*, 2016 edition.

NFPA 72[®], *National Fire Alarm and Signaling Code*, 2016 edition.

NFPA 80, *Standard for Fire Doors and Other Opening Protectives*, 2016 edition.

NFPA 90A, *Standard for the Installation of Air-Conditioning and Ventilating Systems*, 2015 edition.

NFPA 92, *Standard for Smoke Control Systems*, 2015 edition.

NFPA 101[®], *Life Safety Code*[®], 2015 edition.

NFPA 101A, *Guide on Alternative Approaches to Life Safety*, 2016 edition.

NFPA 204, *Standard for Smoke and Heat Venting*, 2015 edition.

NFPA 220, *Standard on Types of Building Construction*, 2015 edition.

NFPA 232, *Standard for the Protection of Records*, 2017 edition.

NFPA 241, *Standard for Safeguarding Construction, Alteration, and Demolition Operations*, 2013 edition.

NFPA 291, *Recommended Practice for Fire Flow Testing and Marking of Hydrants*, 2016 edition.

NFPA 550, *Guide to the Fire Safety Concepts Tree*, 2017 edition.

NFPA 551, *Guide for the Evaluation of Fire Risk Assessments*, 2016 edition.

NFPA 701, *Standard Methods of Fire Tests for Flame Propagation of Textiles and Films*, 2015 edition.

NFPA 730, *Guide for Premises Security*, 2014 edition.

NFPA 731, *Standard for the Installation of Electronic Premises Security Systems*, 2017 edition.

NFPA 750, *Standard on Water Mist Fire Protection Systems*, 2015 edition.

NFPA 780, *Standard for the Installation of Lightning Protection Systems*, 2017 edition.

NFPA 914, *Code for Fire Protection of Historic Structures*, 2015 edition.

NFPA 1221, *Standard for the Installation, Maintenance, and Use of Emergency Services Communications Systems*, 2016 edition.

NFPA 1600[®], *Standard on Disaster/Emergency Management and Business Continuity/Continuity of Operations Programs*, 2016 edition.

NFPA 2001, *Standard on Clean Agent Fire Extinguishing Systems*, 2015 edition.

Fire, Electrical, and Building Safety Resource, www.nfpa.org.

Fire Protection Handbook, NFPA, 2008.

Hall, J. R. "Non-Home Structure Fires by Equipment Involved in Ignition," NFPA, Quincy, MA, 2012.

Isner, M. S. "Investigation Report: Fire in Los Angeles Central Library Causes \$22 Million Loss." *Fire Journal* 81, no. 2 (1987): 56–63, 72–79.

Rosenberg, P. A., *Facility Security: New Threats, New Strategies*, NFPA, Quincy, MA, 2002.

SFPE Engineering Guide to Performance-Based Fire Protection: Analysis and Design of Buildings. Quincy, MA.: National Fire Protection Association; Bethesda, MD.: Society of Fire Protection Engineers, 2000.

SFPE Handbook of Fire Protection Engineering, Quincy, MA: National Fire Protection Association; Bethesda, MD: Society of Fire Protection Engineers, 2008.

Wiley, A. E. "The Charles Klein Law Library Fire, Philadelphia, Pennsylvania." *Fire Journal* 66, no. 6, (November 1972): 15–22.

N.1.2 Other Publications.

N.1.2.1 ASTM Publications. ASTM International, 100 Barr Harbor Drive, P.O. Box C700, West Conshohocken, PA 19428-2959.

ASTM E119, *Standard Test Methods for Fire Tests of Building Construction and Materials*, 2015.

ASTM E1355, *Standard Guide for Evaluating the Predictive Capability of Deterministic Fire Models*, 2012.

ASTM E1472, *Standard Guide for Documenting Computer Software for Fire Models*, 2007 (withdrawn 2011).

N.1.2.2 BHMA Publications. Builders Hardware Manufacturers Association, 355 Lexington Avenue, 15th Floor, New York, NY 10017.

ANSI/BHMA A156.1, *Butts and Hinges*, 2013.

ANSI/BHMA A156.2, *Bored & Preassembled Locks and Latches*, 2011.

ANSI/BHMA A156.4, *Door Controls — Closers*, 2013.

ANSI/BHMA A156.5, *Cylinders and Input Devices for Locks*, 2014.

ANSI/BHMA A156.12, *Interconnected Locks & Latches*, 2013.

ANSI/BHMA A156.13, *Mortise Locks*, 2012.

ANSI/BHMA A156.16, *Auxiliary Hardware*, 2013.

ANSI/BHMA A156.17, *Self-Closing Hinges*, 2014.

ANSI/BHMA A156.23, *Electromagnetic Locks*, 2010.

ANSI/BHMA A156.24, *Delayed Egress Locking Systems*, 2012.

ANSI/BHMA A156.25, *Electrified Locking Devices*, 2013.

ANSI/BHMA A156.26, *Continuous Hinges*, 2012.

ANSI/BHMA A156.28, *Recommended Practices for Mechanical Keying Systems*, 2013.

ANSI/BHMA A156.30, *High Security Cylinders Products*, 2014.

ANSI/BHMA A156.31, *Electric Strikes and Frame Mounted Actuators*, 2013.

N.1.2.3 IEC Publications. International Electrotechnical Commission, 3, rue de Varembé, P.O. Box 131, 1211 Geneva 20, Switzerland.

IEC 62305-2, *Protection against lightning — Part 2: Risk management, Edition 2.0*, 2010-12.

N.1.2.4 IEEE Publications. IEEE, Three Park Avenue, 17th Floor, New York, NY 10016-5997.

IEEE 802.11, *IEEE Standard for Information technology — Telecommunications and information exchange between systems Local and metropolitan area networks — Specific requirements Part 11: Wireless LAN Medium Access Control (MAC) and Physical Layer (PHY) Specifications*, 2012.

N.1.2.5 SPNHC Publications. Society for the Preservation of Natural History Collections, c/o Lisa Palmer, PO Box 797, Washington, DC 20044-0797, www.spnhc.org.

Rose, C. L., C. A. Hawks, and H. H. Genoways. *Storage of Natural History Collections*. 1995.

STASH (Storage Techniques for Art, Science & History Collections). Foundation of the American Institute for Conservation. <http://stashc.com/>

N.1.2.6 Steel Door Institute Publications. Steel Door Institute, 30200 Detroit Road, Westlake, OH 44145.

ANSI/SDI A250.4, *Test Procedure and Acceptance Criteria for Physical Endurance for Steel Doors, Frames and Frame Anchors*, 2011.

ANSI/SDI A250.8, *Specifications for Standard Steel Doors and Frames (SDI-100)*, 2014.

N.1.2.7 UL Publications. Underwriters Laboratories Inc., 333 Pfingsten Road, Northbrook, IL 60062-2096.

ANSI/UL 263, *Standard for Fire Tests of Building Construction and Materials*, 2011, revised 2015.

ANSI/UL 294, *Standard for Access Control System Units*, 2013, revised 2015.

ANSI/UL 305, *Standard for Panic Hardware*, 2012, revised 2014.

ANSI/UL 437, *Standard for Key Locks*, 2013.

ANSI/UL 768, *Standard for Combination Locks*, 2006, revised 2013.

ANSI/UL 1034, *Standard for Burglary-Resistant Electric Locking Mechanisms*, 2011.

UL 634, *Connectors and Switches for Use with Burglar-Alarm Systems*, 2007, revised 2015.

UL 681, *Standard for Installation and Classification of Burglar and Holdup Alarm Systems*, 2014.

UL 2058, *Outline of Investigation for High Security Electronic Locks*, 2005.

N.1.2.8 U.S. Government Publications. U.S. Government Publishing Office, 732 North Capitol Street, NW, Washington, DC, 20401-0001.

FEMA Publication P-501 (Catalog Number 08336-1), *National Incident Management System*, U.S. Department & Homeland Security, December 2008.

"How to Define Categories of Historic Properties," *National Register Bulletin 15, How to Apply the National Register Criteria for Evaluation*, 1991.

NPS Director's Order #18: Wildland Fire Management, U.S. Department of the Interior, National Park Service, January 16, 2008. <http://www.nps.gov/policy/DOrders/DO-18.html>.

Review and Update of the 1995 Federal Wildland Fire Management Policy, National Interagency Fire Center, January 2001. <http://www.nifc.gov>.

N.1.2.9 Other Publications.

Before and After Disasters, Heritage Preservation, 2005. www.heritagepreservation.org/PDFS/Disaster.pdf.

Borenstein, S. W., *Microbiologically Influential Corrosion Handbook*, Woodhead Publishing Limited, 1994.

British Standard BS 7974, *Application of Fire Safety Engineering Principles to the Design of Buildings*, British Standards Institution, London, UK, 2001.

Cotton, P. E., "Fire Tests of Library Book Stacks," report dated December 21, 1959.

Cutler, Harold R., "Engineering Analysis of Compact Storage Fire Tests," unpublished report prepared by Firepro, Inc. for the Library of Congress, 1979.

Dorge, Valerie, and Sharon L. Jones, compilers, *Building an Emergency Plan: A Guide for Museums and Other Cultural Institutions*. The Getty Conservation Institute, 1999. www.getty.edu/conservation/publications/pdf_publications/emergency_plan.pdf.

Draft Paper on the Characteristics of RFID-Systems, The Association for Automatic Identification and Mobility, Warrendale, PA, 2000.

Field Guide to Emergency Response, Heritage Preservation, 1012 14th Street, NW, Suite 1200, Washington, DC 20005.

Field Manual FM-3-19.30, Physical Security, Headquarters, Department of the Army, 2001.

Fire Safety Engineering Guidelines, Australian Building Codes Board, Canberra, ACT, 2001.

Fontana, M. G., and Greene, N. D., *Corrosion Engineering*, McGraw Hill, 1978.

Guidelines for the Security of Rare Books, Manuscripts, and Other Special Collections, Association of College & Research Libraries, American Library Association, 50 East Huron Street, Chicago, IL 60611-2795.

Hatchfield, P., *Pollutants in the Museum Environment*, London, Archetype Publications Ltd., 85, 2002.

Honey, G., *Electronic Access Control*, Newnes, Oxford, UK, 2000.

Lougheed, G. D., J. R. Mawhinney, and J. O'Neill, "Full-Scale Fire Tests and the Development of Design Criteria for Sprinkler Protection of Mobile Shelving Units." *Fire Technology* 30, no. 1 (1994).

McLane, B., and Aulner, C., *CCTV Systems, Design & Installation*, National Training Center, Inc., Las Vegas, NV, 2004.

"A Legal Primer on Managing Museum Collections," Malero, Marie, second edition 1998.

Pierce, C., *Application & Design of CCTV*, LeapFrog Training & Consulting, Davenport, IA, 2002.

Open for Business, Institute for Business and Home Safety, 2006. www.ibhs.org

"Risk and Insurance Management Manual for Libraries," Mary Breighner and William Payton, edited by Jeanne Drewes, ALA 2005 ISBN 0-8389-8325-1.

Roberge, P. R., *Handbook of Corrosion Engineering*, McGraw Hill, 2000.

Sampson, R. L., *A Practical Guide to Central Station Burglar Alarm Systems*, Central Station Alarm Association, Bethesda, MD, 1997.

Trinkley, Michael. *Hurricane! Surviving the big one: a primer for libraries, museums and archives*, 2nd edition, Columbia, SC: Chicora Foundation; Atlanta, GA: Southeastern Library Network, c1998.

Waters, P., "Procedures for Salvage of Water-Damaged Library Materials," Restoration Officer, Library of Congress, 1975. (Copies available upon request from the Library of Congress, Washington, DC 20540.)

Wisconsin Historic Building Code, Madison, WI:Wisconsin Administrative Code.

World Heritage List, United Nations Educational, Scientific, and Cultural Organization, UNESCO World Heritage Centre, Paris, France, 2009.

N.2 Informational References. The following documents or portions thereof are listed here as informational resources only. They are not a part of the requirements of this document.

N.2.1 NFPA Publications. National Fire Protection Association, 1 Batterymarch Park, Quincy, MA 02169-7471.

NFPA 70®, *National Electrical Code®*, 2017 edition.

NFPA 80A, Recommended Practice for Protection of Buildings from Exterior Fire Exposures, 2017 edition.

NFPA 1144, Standard for Reducing Structure Ignition Hazards from Wildland Fire, 2013 edition.

Marchant, E. W. "Preventing Fire in Historic Buildings: The Acceptable Risk." *Fire Technology*, 25, no. 2 (May 1989):165–176.

"Protecting Our Heritage, A Discourse on Fire Protection and Prevention in Historic Buildings and Landmarks," 2nd edition, 1970.

N.2.2 ASTM Publications. ASTM International, 100 Barr Harbor Drive, West Conshohocken, PA 19428-2959.

ASTM E84, *Standard Test Method for Surface Burning Characteristics of Building Materials*, 2015b.

ASTM E136, *Standard Test Method for Behavior of Building Materials in a Vertical Tube Furnace at 750°C*, 2016.

N.2.3 HUD Publications. National Institute of Building Sciences for the Department of Housing and Urban Development, 1201 L Street, NW, Suite 400, Washington, DC 20005-4024.

Brenner, W. and D. Hattis. *Rehabilitation Guidelines 1986*. Vol. 5. Egress Guideline for Residential Rehabilitation. [2nd ed.]. Washington, DC: U.S. Department of Housing and Urban Development: 1986–1997.

Brenner, William and David Hattis. *Rehabilitation Guidelines 1986*. Vol. 8., Rehabilitation Guidelines 1986. No. 8. “Guideline on Fire Ratings of Archaic Materials and Assemblies.” [2nd ed.]. Washington, DC: U.S. Department of Housing and Urban Development: 1986–1997.

N.2.4 Other Publications.

Alsford, D., “Fire Safety in Museums,” *MUSE* 2, no. 2 (Summer 1984):18–23. Canadian Museums Association, Ottawa, Ontario,

“Regulating Existing Buildings.” *APT Bulletin* 13, no. 2, 1981.

ASA A2, *Standard Specifications for Fire Tests of Building Construction and Materials*, 1932.

Bailey, A., D. W. Insall, and P. Kilshaw, *Fire Protection Measures for the Royal Palaces: A Report*. London: HMSO, 1993.

“Building Codes and Historic Preservation,” *Preservation Forum*, Vol. 2, No. 1, Spring 1988, pp. 11–17.

“Fire Prevention in the Conservation Laboratory,” New York Center for Occupational Hazards, 1985.

“Fire Protection in Old Buildings and Historic Town Centres,” London: Fire Protection Association, 1992.

“Fire Safety Retrofitting in Historic Buildings,” Washington, DC, Advisory Council on Historic Preservation and the General Services Administration, 1989.

Fischer, Walter R., “Fire Safety Systems: Protecting Our Treasures from Threat of Fire,” *Technology and Conservation*, Vol. 25, No. 2, February 1980, pp. 21–24.

Fisher, T., “Fire Breaks: Fire Safety in Historic Buildings,” *Progressive Architecture*, Vol. 67, No. 11, November 1986, pp. 116–121.

Fishlock, M., *The Great Fire at Hampton Court*, London, The Herbert Press, 1992.

Goldstone, B. M. *Hazards from the Concentration of Solar Radiation by Textured Window Glass*. London: Dept. of the Environment, Building Research Establishment; H.M.S.O., 1982.

Harmathy, T. Z., “Ten Rules of Fire Endurance Ratings,” *Fire Technology*, May 1965.

Hunter, John E., “Security for Museums and Historic Houses: An Annotated Bibliography,” Technical Leaflet 114 (History News 34:4), Nashville, TN: American Association for State and Local History, 1979.

Kaplan, M. E. *Safety, Building Codes and Historic Buildings*. Information series no. 57 Washington, DC: National Trust for Historic Preservation, 1992.

Kidd, S. *Heritage Under Fire: A Guide to the Protection of Historic Buildings*. London: Fire Protection Association for the UK Working Party on Fire Safety in Historic Buildings, 2nd ed., 1995.

Maintenance of Fire Protection Systems. NAVFAC MO-117; Air Force AFM - 91-37; Army TM - 5-695. [Washington, DC]: Departments of the Army, The Navy, and The Air Force, 1989.

Martin, J. H. and C. K. Edwards, *The Corning Flood: Museum Under Water*. Corning, NY: The Museum, 1977.

Morris, J. A., comp., *Alloway, the Protection and Preservation of Its Memorials of Robert Burns*. Ayrshire: Ayrshire Association of Federated Burns Clubs, 1930.

Morris, J., *The Library Disaster Preparedness Handbook*. Chicago: American Library Association, 1986.

Morris, J., *Managing the Library Fire Risk*. 2nd ed. [Berkeley]: University of California, 1979.

Nelson, C. L., *Protecting the Past from Natural Disasters*. Washington, DC: Preservation Press, National Trust for Historic Preservation, 1991.

Parnell, A. C. and D. H. Ashford, *Fire Safety in Historic Buildings. Part 1, Fire Dangers and Fire Precautions*. S.P.A. technical pamphlet 6. [London]: Society for the Protection of Ancient Buildings with the Fire Protection Association, 1981.

Pielert, J. H. Removing Regulatory Restraints to Building Rehabilitation: The Massachusetts Experience. Washington, DC: U.S. Dept. of Commerce, National Bureau of Standards, 1981. GovDoc: C 13.10:623.

Protecting Federal Records Centers and Archives from Fire: Report of the General Services Administration Advisory Committee on the Protection of Archives and Records Centers. Washington: General Services Administration, Public Buildings Service: For sale by the Supt. of Docs., U.S. Govt. Print. Off., 1977. GovDoc: GS 6.2:F 5½

The Secretary of the Interior’s Standards for Rehabilitation and Guidelines for Rehabilitating Historic Buildings. National Park Service, U.S. Department of the Interior, 1983. <http://www.nps.gov/history/hps/tps/tax/rhb>

Sellers, D. Y. and R. Strassberg, “Anatomy of a Library Emergency,” *Library Journal*, Vol. 98, No. 17 (October 1, 1973), pp. 2824–2827.

Spawn, W., “After the Water Comes,” *PLA Bulletin* (Pennsylvania Library Association), Vol. 28, No. 6, November 1973, pp. 243–251.

Tillotson, R. G., “Museum Security,” Paris: International Council of Museums and American Association of Museums, 1977.

Tiszkus, A. T., and E. G. Dressler, “Fire Protection Planning for Cultural Institutions: Blending Risk Management, Loss Prevention, and Physical Safeguards,” *Technology and Conservation*, Vol. 5, No. 2, Summer 1980, pp. 18–23.

Wisconsin Administrative Code, Chapter 70. Historic Buildings.

Uniform Building Code, Whittier, CA: ICBO, 1979.

Wilson, J. A., "Fire Fighters – An Automatic Fire Suppression System Is Among Your Museum's Best and Safest Forms of Insurance," *Museum News* (American Association of Museums), Washington, DC, Vol. 68, No. 6, November/December 1989, pp. 68–72.

N.3 References for Extracts in Informational Sections.

NFPA 4, *Standard for Integrated Fire Protection and Life Safety System Testing*, 2015 edition.

NFPA 72[®], *National Fire Alarm and Signaling Code*, 2016 edition.

NFPA 730, *Guide for Premises Security*, 2014 edition.

NFPA 5000[®], *Building Construction and Safety Code*[®], 2015 edition.

Index

Copyright © 2016 National Fire Protection Association. All Rights Reserved.

The copyright in this index is separate and distinct from the copyright in the document that it indexes. The licensing provisions set forth for the document are not applicable to this index. This index may not be reproduced in whole or in part by any means without the express written permission of NFPA.

- | | | | |
|--------------------------------------------------------------------------------------------------------------------------------------------------------------------------------------------------------------------------------------------------------------------------------------------------------------------------------------------------------------------------------------------------------------------------------------------------------------------------------------------------------------------------------------------------------------------------------------------------------------------------------------------------------------------------------------------------------------------------------------------------------------------------------------------------------------------------------------------------------------------------------------------------------------------------------|----------------------------------------------------------------------------------------------------------------------------------------------------------------------------------------------------------------------------------------------------------------------------------------------------------------------------------------------------------------------------------------------------------------------------------------------------------------------------------------------------------------------------------------------------------------------------------------------|---------------------------------------------------------------------------------------------------------------------------------------------------------------------------------------------------------------------------------------------------------------------------------------------------------------------------------------------------------------------------------------------------------------------------------------------------------------------------------------------------------------------------------------------------------------------------------------------------------------------------------------------------------------------------------------------------------------------------------------------------------------------------------------------------------------------------------------------------------------------------------------------------------------------------------------------------------------------------------------------------------------------------------------------------------------------------------------------------------|----------------------------------------------------------------------------------------------------------------------------------------------------------------------------------------------------------------------------------------------------|
| <p style="text-align: center;">-A-</p> <p>Addition
Definition, 3.3.1</p> <p>Administration, Chap. 1
Application, 1.3, A.1.3
Existing Cultural Resource Property Occupancies, 1.3.2
New Cultural Resource Property Occupancies, 1.3.1
Compliance Options, 1.5
General, 1.5.1
Management Operational Systems, 1.5.4
Performance-Based Options, 1.5.3
Prescriptive-Based Options, 1.5.2
Enforcement, 1.6, A.1.6
Equivalency, 1.4
Purpose, 1.2, A.1.2
Scope, 1.1</p> <p>Alter/Alteration
Definition, 3.3.2</p> <p>Analysis
Definition, 3.3.3
Sensitivity Analysis
Definition, 3.3.3.1
Uncertainty Analysis
Definition, 3.3.3.2</p> <p>Approved
Definition, 3.2.1, A.3.2.1</p> <p>Arson
Definition, 3.3.4</p> <p>Authority Having Jurisdiction (AHJ)
Definition, 3.2.2, A.3.2.2</p> | <p style="text-align: center;">-B-</p> <p>Barrier
Definition, 3.3.5
Fire Barrier
Definition, 3.3.5.1
Smoke Barrier
Definition, 3.3.5.2</p> <p>Basics of Fire and Fire Protection Systems, Annex C
Classification of Fires, C.1
Fire Detection and Alarm Systems, C.2
Glossary of Fire Protection Systems, C.3</p> <p>Book Stack
Definition, 3.3.6
Multi-Tier Book Stack
Definition, 3.3.6.1, A.3.3.6.1
Single-Tier Book Stack
Definition, 3.3.6.2</p> <p>Buildings
Definition, 3.3.7, A.3.3.7</p> | <p style="text-align: center;">-C-</p> <p>Existing Building
Definition, 3.3.7.1</p> <p>Character-Defining Feature
Definition, 3.3.8</p> <p>Code
Definition, 3.2.3, A.3.2.3</p> <p>Collections
Definition, 3.3.9</p> <p>Collections Storage Room
Definition, 3.3.10</p> <p>Combination System
Definition, 3.3.11</p> <p>Compact Storage Fire Tests, Annex G
Introduction, G.1</p> <p>Compact Storage Module
Definition, 3.3.12</p> <p>Compact Storage System
Definition, 3.3.13</p> <p>Compact Storage Test Program, Annex H</p> <p>Compartment
Definition, 3.3.14</p> <p>Compliance
Compliance Audit
Definition, 3.3.15.1
Definition, 3.3.15</p> <p>Conservation
Definition, 3.3.16</p> <p>Cultural Resource Properties
Definition, 3.3.17, A.3.3.17</p> <p>Cultural Resource Property Protection Self-Inspection Checklist, Annex I
Quarterly Cultural Resource Property Protection Self-Inspection Checklist, I.1</p> | <p style="text-align: center;">-D-</p> <p>Damage Limitation
Definition, 3.3.18</p> <p>Definitions, Chap. 3</p> <p>Design Specification
Definition, 3.3.19</p> <p>Design Team
Definition, 3.3.20</p> |
| | | <p style="text-align: center;">-E-</p> <p>Electronic Premises Security System
Definition, 3.3.21</p> <p>Explanatory Material, Annex A</p> | |

Exposure Fire

Definition, 3.3.22

-F-**Factory Mutual Engineering Division Laboratory Report, Annex L****Fire Alarm System**

Definition, 3.3.23

Fire Compartment

Definition, 3.3.24

Fire Experience in Cultural Properties, Annex B

General, B.1

Fire Experience, B.1.1

Fire Suppression Systems, B.1.3

When Fire Prevention Fails, B.1.2

Library Fires, B.3

Illustrative Fires, B.3.2

Alexander Blok Library, St. Petersburg, Russia —
February 20, 2004, B.3.2.4Anna Amalia Library, Weimar, Germany — September
2004, B.3.2.3Bailey-Howe Library, University of Vermont, Burlington
— March 21, 1990, B.3.2.23Bibliotheca Alexandrina, Alexandria, Egypt — March 2,
2003, B.3.2.6Broward County Main Library, Fort Lauderdale, Florida
— March 23, 1993, B.3.2.19Bryan College Library Collections, Dayton Tennessee —
February 2000, B.3.2.10Calgary Public Library, Thornhill Branch, Calgary,
Alberta, Canada — April 1, 1990, B.3.2.22Carrington City Library, Carrington City, North Dakota
— November 5, 1994, B.3.2.15Central Library, Virginia Beach, Virginia — January 22,
2000, B.3.2.12Ceres Public Library, Ceres, California — August 14,
1977, B.3.2.31Dakota County Library Branch, Hastings, Minnesota —
June 4, 1993, B.3.2.18Georgetown Neighborhood Library, DC Pubic Library,
Washington, DC — April 30, 2007, B.3.2.2Glasgow School of Art Library, Glasgow, Scotland — May
23, 2014, B.3.2.1Glasgow University, Scotland, UK — October 25, 2001, B.
3.2.7Grand Canyon Community Library, Grand Canyon
Village, Arizona — March 18, 1994, B.3.2.17Hollywood Regional Library, Hollywood, California —
May 2, 1982, B.3.2.28Jewish Theological Seminary Library, New York, New
York — April 1966, B.3.2.34Library of USSR Academy of Science, Leningrad, Russia
— February 14, 1988, B.3.2.25Linköping City Library, Linköping, Sweden — September
20, 1996, B.3.2.13Los Angeles Central Library, Los Angeles, California, B.
3.2.26

April 29, 1986, B.3.2.26.1

October 11, 1988, B.3.2.26.3

September 3, 1986, B.3.2.26.2

Michigan State Library and Office Building, Lansing,
Michigan — February 8–13, 1951, B.3.2.36

Minnesota Library — 2000, B.3.2.8

National Archives — February 29, 2000, B.3.2.9

Nellie McClung Public Library, Victoria, British
Columbia, Canada — December 4, 1989, B.
3.2.24New York University Library, New York, New York —
February 1951, B.3.2.37New York University Library, New York, New York —
January 1965, B.3.2.35Norwich Central Library, Norwich, England — August 1,
1994, B.3.2.16Rio Vista Library, Rio Vista, California — January 16,
1993, B.3.2.20Saint Joseph State Hospital Library, Saint Joseph,
Missouri — July 31, 1982, B.3.2.27San Diego Aerospace Museum and Library, San Diego,
California — February 22, 1978, B.3.2.30South Bend Public Library, South Bend, Indiana —
October 28, 1992, B.3.2.21Temple University Law Library, Philadelphia,
Pennsylvania — July 1972, B.3.2.33University of Georgia Main Library — July 23, 2003, B.
3.2.5University of Michigan Department of Government
Library, Ann Arbor, Michigan — June 6,
1950, B.3.2.38University of Toronto Engineering Library, Toronto,
Ontario — February 1977, B.3.2.32University of Utah, Salt Lake City — December 17,
1981, B.3.2.29Village Library, Centerburg Ohio — January 28, 2000, B.
3.2.11

Virginia Library, Hampton, Virginia — July 1996, B.3.2.14

Why Library Fires Spread, B.3.1

Museums, B.2

Illustrative Fires, B.2.2

Biblical Arts Center, Dallas Texas — June 2005, B.2.2.4

Byer Museum of Art, Evanston, IL — December 31,
1984, B.2.2.20Castle Museum of Saginaw County, Saginaw, Michigan —
November 20, 2004, B.2.2.9Cuming Museum, London, England — March 26,
2013, B.2.2.2Czech National Museum, Prague, Czech Republic —
February 12, 2016, B.2.2.1Fort Hill-John C. Calhoun Shrine, Clemson, SC — May
30, 1988, B.2.2.17Goa State Museum, Goa, India — January 11, 2005, B.
2.2.8Henry Ford Museum, Dearborn, MI — August 9, 1970, B.
2.2.24Huntington Gallery, San Marino, CA — October 17,
1985, B.2.2.19Louisiana State Museum (The Cabildo), New Orleans,
LA — May 11, 1988, B.2.2.18Millicent Museum, Millicent Australia — May 1, 2005, B.
2.2.6Mosaic Templars Building, Little Rock, Arkansas —
March 16, 2005, B.2.2.7Museum of Modern Art, New York City — April 15,
1958, B.2.2.25

- Museum of Modern Art, Rio de Janeiro, Brazil — July 8, 1978, B.2.2.21
- National Capital Trolley Museum, Colesville, Maryland — September 28, 2003, B.2.2.14
- National Motorcycle Museum, Bickenhill, England — September 16, 2003, B.2.2.15
- National Museum of American History (Smithsonian Institution), Washington, DC — September 30, 1970, B.2.2.23
- National Museum of Natural History (Smithsonian Institution) Washington, DC — January 22, 1989, B.2.2.16
- Sallows Military Museum, Alliance, Nebraska — May 2005, B.2.2.5
- San Diego Aerospace Museum, San Diego, CA — February 22, 1978, B.2.2.22
- Sardine Museum, Kujukuri, Chiba, Japan — July 30, 2004, B.2.2.12
- Smithsonian National Museum of Natural History — February 7, 2011, B.2.2.3
- Steele County Historical Museum, Hope, North Dakota — October 29, 2004, B.2.2.10
- Yaa Asantewaa Museum, Ashanti, Ghana — July 25, 2004, B.2.2.13
- Yankee Air Museum at Willow Run Airport, Van Buren Township, Michigan — October 9, 2004, B.2.2.11
- Why Museum Fires Spread, B.2.1
- Places of Worship, B.4
- Illustrative Fires in Places of Worship, B.4.2
- Arizona Church — 1996, B.4.2.36
- Barrington United Methodist Church, Barrington, IL — October 28, 1998, B.4.2.26
- Bethel Church, Elizabeth, West Virginia — December, 2004, B.4.2.12
- Central Synagogue, New York, New York — August, 1998, B.4.2.28
- Christ the King Catholic Church, Chicago, Illinois — October 7, 2015, B.4.2.2
- Ebenezer Baptist Church, Pittsburgh, Pennsylvania — March, 2004, B.4.2.14
- Exeter Presbyterian Church, Exeter, New Hampshire — November, 2003, B.4.2.16
- First Presbyterian Church, Lexington, Virginia — August, 2000, B.4.2.21
- Harbin New Synagogue, Beijing, China — November, 2004, B.4.2.13
- Immaculate Heart of Mary Catholic Church, Phoenix, Arizona — April, 2000, B.4.2.22
- Kansas Church — 1999, B.4.2.25
- Kentucky Church — 1997, B.4.2.33
- Kharkiv Synagogue, Kiev, Ukraine — September, 1998, B.4.2.27
- Laurel Grove Baptist Church, Franconia, Virginia — December, 2004, B.4.2.11
- Lutheran Church of Hope, Anchorage, Alaska — January 30, 2016, B.4.2.1
- Michigan Church — 1997, B.4.2.32
- Minnesota Church — 1996, B.4.2.35
- New Shiloh Christian Center, Melbourne, Florida — February 16, 2015, B.4.2.4
- Oklahoma Church — 1996, B.4.2.34
- Our Lady of the Rosary Church, Pirenopolis, Brazil — September, 2002, B.4.2.18
- Pennsylvania Church — 1998, B.4.2.29
- Praise International Church, Vancouver, British Columbia — January, 2004, B.4.2.15
- Saint-Donatien Basilica, Nantes, France — June 14, 2015, B.4.2.3
- Salem United Methodist Church, Allentown, Pennsylvania — August 2001, B.4.2.20
- Second Baptist Church, Houston, Texas — January 1, 2015, B.4.2.5
- St. Catherine's Church, Gdansk, Poland — May 23, 2006, B.4.2.8
- St. John's Lutheran Church, Sycamore, Illinois — February 9, 2003, B.4.2.17
- St. Jude's Cathedral, Iqaluit, Nunavut — November 13, 2005, B.4.2.10
- St. Luke's, Belfast, Pennsylvania — February 29, 2000, B.4.2.23
- St. Mary Magdalene Church, Los Angeles, California — July 2 & 3, 1999, B.4.2.24
- St. Mel's Cathedral, Longford, Ireland — December 25, 2009, B.4.2.6
- St. Michael Catholic Church, Wheaton, Illinois — March, 2002, B.4.2.19
- Texas Church — 1998, B.4.2.31
- Trinity Cathedral, St. Petersburg, Russia — August 25, 2006, B.4.2.7
- University City Church, Charlotte, North Carolina — March 20, 2006, B.4.2.9
- Wisconsin Church — 1996, B.4.2.37
- Wisconsin Church — 1998, B.4.2.30
- Why Fires in Places of Worship Spread, B.4.1
- Fire Hazard**
- Definition, 3.3.25
- Fire Model**
- Definition, 3.3.26
- Fire Prevention, Chap. 11**
- Decorations, 11.2
- Electrical Hazards, 11.8
- Cabling, 11.8.5
- Fire Spread Control, 11.3, A.11.3
- General, 11.1, A.11.1
- Hot Work, 11.6
- Hot Work Permit, 11.6.2
- Limitations on Hot Work Operations, 11.6.1
- Housekeeping, 11.4, A.11.4
- Attics, 11.4.2
- Packing Materials, 11.4.8
- Lightning Protection, 11.11, A.11.11
- Open Flames, 11.7
- Approval, 11.7.1
- Chimneys, 11.7.3
- Precautions, 11.7.2
- Penetrations, 11.9
- Protection from Wildland Fires, 11.12
- Smoking, 11.5, A.11.5
- Structural Fire Protection, 11.10
- Water Control, 11.13

Fire Protection System

Definition, 3.3.27

Fire Resistance Rating

Definition, 3.3.28

Fire Retardant

Definition, 3.3.29, A.3.3.29

Fire Safety Manager

Definition, 3.3.30, A.3.3.30

Fire System Maintenance Checklists, Annex J

Introduction, J.1

Maintenance of Automatic Sprinkler and Standpipe Systems, J.2

Maintenance of Dry Chemical Systems, J.11

Maintenance of Emergency Generator and Emergency Lighting, J.9

Maintenance of Fire Detection and Alarm Systems, J.3

Maintenance of Fire Doors and Fire Dampers, J.12

Maintenance of Fire Hose Stations, J.4

Maintenance of Fire Hydrants, J.5

Maintenance of Fire Pumps, J.6

Maintenance of Halon Systems, J.8

Maintenance of Lightning Protection Systems, J.15

Maintenance of Portable Fire Extinguishers, J.14

Maintenance of Stair Pressurization and Smoke Venting Systems, J.13

Maintenance of Water Spray Systems for Kitchens, J.10

Maintenance of Water Storage Tanks Used for Fire Protection, J.

7

Fire Watch

Definition, 3.3.32

Firestop

Definition, 3.3.31

Fuel Load

Definition, 3.3.33

-G-**Goal**

Definition, 3.3.34

Goals and Objectives, Chap. 4

General, 4.1

Goals, 4.2

Building Preservation, 4.2.2

Collection Preservation, 4.2.1

Continuity of Operations, 4.2.3

Objectives, 4.3, A.4.3

Building Preservation, 4.3.2

Collection Preservation, 4.3.1

Continuity of Operations, 4.3.3

Governing Body

Definition, 3.3.35

-H-**Hazard**

Definition, 3.3.36

Hazardous Area

Definition, 3.3.37, A.3.3.37

Historic Fabric

Definition, 3.3.38

Historic Structure

Definition, 3.3.39, A.3.3.39

Hot Work

Definition, 3.3.40

-I-**Impairment**

Definition, 3.3.41, A.3.3.41

Incendiary Fire

Definition, 3.3.42, A.3.3.42

Informational References, Annex N**Initiating Device**

Definition, 3.3.43

Input Data Specification

Definition, 3.3.44

Inspection, Testing, and Maintenance of Protection Systems, Chap. 12

Chimneys, 12.7

Electrical Systems, 12.8, A.12.8

Electronic Premises Security Systems, 12.3

Inspection, 12.3.3, A.12.3.3

Maintenance, 12.3.5

Testing, 12.3.4

Fire Barriers, 12.9

Fire Extinguishers, 12.11

Fire Protection Systems, 12.2

Inspection, 12.2.3, A.12.2.3

Maintenance, 12.2.5

Responsibility, 12.2.2

Testing, 12.2.4

Fire Retardant-Treated Materials, 12.10

General, 12.1, A.12.1

Heating, Air-Conditioning, and Cooking Equipment, 12.6

Impairments to Electronic Premises Security Systems, 12.5

General, 12.5.1

Planned Impairments, 12.5.2

Procedure, 12.5.3

Restoring Systems to Service, 12.5.4

Impairments to Fire Protection Systems, 12.4

General, 12.4.1

Planned Impairments, 12.4.2

Procedure, 12.4.3

Restoring Systems to Service, 12.4.4

-L-**Library**

Definition, 3.3.45, A.3.3.45

Limited-Combustible Material

Definition, 3.3.46

Listed

Definition, 3.2.4, A.3.2.4

-M-**Management Operational Systems**

Definition, 3.3.47, A.3.3.47

Management Operational Systems, Chap. 10

Compliance Audit, 10.8

- Closing Conference, 10.8.3
 - Documentation, 10.7
 - Emergency Response, 10.5
 - Enforcement, 10.9
 - General, 10.1, A.10.1
 - Modification of the Plan, 10.10
 - Operational Requirements, 10.4
 - Procedures for Opening and Closing, 10.4.4
 - Reporting Incidents, 10.3
 - Responsibility/Authority, 10.2
 - Training, 10.6
 - Drills, 10.6.3
 - Means of Egress**
 - Definition, 3.3.48
 - Measuring the Impact of Fire Extinguisher Agents on Cultural Resource Materials**, Annex M
 - Executive Summary, M.2
 - General, M.1
 - Modification**
 - Definition, 3.3.49
 - Museum**
 - Definition, 3.3.50, A.3.3.50
 - Museums, Libraries, and Their Collections**, Chap. 14
 - Collection Storage Rooms, 14.4
 - Book Stacks, 14.4.7, A.14.4.7
 - Electronic Media, 14.4.6
 - Storage of Video, Audio Tapes, and Computer Media, 14.4.6.2
 - Fire Prevention, 14.4.1, A.14.4.1
 - Housekeeping, 14.4.1.5
 - Hazardous Materials, 14.4.4
 - Cellulose Nitrate Film, 14.4.4.1, A.14.4.4.1
 - Pyroxylin Plastic, 14.4.4.2
 - Wet Collections, 14.4.4.3
 - Security, 14.4.3
 - Storage of Records, 14.4.5, A.14.4.5
 - Fire Prevention, 14.2
 - Appliances, 14.2.9
 - Decorative Materials, 14.2.3
 - Drapes, Curtains, and Props, 14.2.1
 - Fire-Retardant Treatments, 14.2.2
 - Flammable and Combustible Liquids, 14.2.7
 - Hazardous Areas, 14.2.8
 - Print Shops and Binderies, 14.2.8.3
 - Hot Work and Open Flames, 14.2.6
 - Housekeeping, 14.2.4, A.14.2.4
 - General, 14.1
 - Planning, 14.1.6, A.14.1.6
 - Special Exhibits, 14.1.7
 - Security, 14.3, A.14.3
- N-
- New Construction, Addition, Alteration, Renovation, and Modification Projects**, Chap. 9
 - Application of Code, 9.2, A.9.2
 - Design Review, 9.11
 - General, 9.1, A.9.1
 - Operations, 9.5
 - Options, 9.10
 - Option Evaluation and Selection, 9.10.3
 - Selection Criteria, 9.10.3.1, A.9.10.3.1
 - Performance-Based Option, 9.13, A.9.13
 - Application, 9.13.1
 - Approval, 9.13.38
 - Approved Qualifications, 9.13.3, A.9.13.3
 - Building Design Specifications, 9.13.25
 - Collections Preservation Performance Criteria, 9.13.10
 - Continuity of Operations Criteria, 9.13.12
 - Cultural Resource Property Preservation Criteria, 9.13.11, A.9.13.11
 - Design Fire Scenario Data, 9.13.17
 - Design Fire Scenarios, 9.13.14, 9.13.28, A.9.13.14
 - Design Specifications and Other Conditions, 9.13.13
 - Assumptions and Design Specifications Data, 9.13.13.2
 - Building Characteristics, 9.13.13.3, A.9.13.13.3
 - Consistency of Assumptions, 9.13.13.9, A.9.13.13.9
 - Emergency Response Personnel, 9.13.13.6
 - Occupant Characteristics, 9.13.13.5
 - General, 9.13.13.5.1, A.9.13.13.5.1
 - Location, 9.13.13.5.5
 - Occupant Load, 9.13.13.5.6, A.9.13.13.5.6
 - Response Characteristics, 9.13.13.5.4, A.9.13.13.5.4
 - Staff Assistance, 9.13.13.5.7, A.9.13.13.5.7
 - Off-Site Conditions, 9.13.13.8
 - Operational Status and Effectiveness of Building Features and Systems, 9.13.13.4, A.9.13.13.4
 - Post-Construction Conditions, 9.13.13.7, A.9.13.13.7
 - Special Provisions, 9.13.13.10, A.9.13.13.10
 - Documentation Requirements, 9.13.23, A.9.13.23
 - Evaluation, 9.13.15, A.9.13.15
 - Evaluation of Proposed Design, 9.13.18
 - Evidence of Modeler Capability, 9.13.34
 - Final Determination, 9.13.6
 - Goals and Objectives, 9.13.2
 - Independent Review, 9.13.4, A.9.13.4
 - Initial Compliance Audit, 9.13.37
 - Input Data, 9.13.19, 9.13.29
 - Maintenance of Design Features, 9.13.7, A.9.13.7
 - Modeling Features, 9.13.33, A.9.13.33
 - Occupant Characteristics, 9.13.27
 - Output Data, 9.13.20, 9.13.30, A.9.13.20
 - Performance Criteria, 9.13.9, 9.13.26
 - Periodic Compliance Audit, 9.13.39
 - Prescriptive Requirements, 9.13.32
 - Records, 9.13.36
 - Required Design Fire Scenarios, 9.13.16, A.9.13.16
 - Design Fire Scenario 1, 9.13.16.2, A.9.13.16.2
 - Design Fire Scenario 2, 9.13.16.3, A.9.13.16.3
 - Part A, 9.13.16.3.1
 - Part B, 9.13.16.3.2
 - Design Fire Scenario 3, 9.13.16.4, A.9.13.16.4
 - Part A, 9.13.16.4.1
 - Part B, 9.13.16.4.2
 - Design Fire Scenario 4, 9.13.16.5, A.9.13.16.5
 - Part A, 9.13.16.5.1

- Part B, 9.13.16.5.2
 - Design Fire Scenario 5, 9.13.16.6, A.9.13.16.6
 - Part A, 9.13.16.6.1
 - Part B, 9.13.16.6.2
 - Design Fire Scenario 6, 9.13.16.7, A.9.13.16.7
 - Design Fire Scenario 7, 9.13.16.8, A.9.13.16.8
 - Design Fire Scenario 8, 9.13.16.9, A.9.13.16.9
 - Safety Factors, 9.13.31
 - Safety Factors, 9.13.22, A.9.13.22
 - Sources of Data, 9.13.5
 - Special Definitions, 9.13.8
 - Technical References and Resources, 9.13.24
 - Use of Performance-Based Option, 9.13.35
 - Validity, 9.13.21
 - Plans and Designs, 9.9
 - Potential Threat Identification and Evaluation, 9.7
 - Means of Egress, 9.7.2
 - Precautions During New Construction, Addition, Alteration, Renovation, and Modification Projects, 9.14, A.9.14
 - Construction Equipment, 9.14.21
 - Construction Materials, 9.14.22, A.9.14.22
 - Construction Offices, Trailers, and Sheds, 9.14.20
 - Contractor Selection, 9.14.3, A.9.14.3
 - Contracts, 9.14.4, A.9.14.4
 - Control Area, 9.14.7
 - Demolition Work, 9.14.27
 - Egress, 9.14.15
 - Electrical Systems, 9.14.19
 - Emergency Communication, 9.14.8
 - Fire Protection Systems, 9.14.13
 - Automatic Fire Suppression Systems, 9.14.13.4
 - Fire Alarm Systems, 9.14.13.1
 - Protection During Construction, 9.14.13.1.2, A.9.14.13.1.2
 - Fire Suppression Systems, 9.14.13.2
 - Portable Fire Extinguishers, 9.14.13.5
 - Standpipes, 9.14.13.3
 - Flammable and Combustible Liquids, 9.14.18
 - Housekeeping, 9.14.29
 - Ignition Sources, 9.14.16
 - Initial Meeting/Indoctrination of Contractors, 9.14.5, A.9.14.5
 - Other Hazardous Operations, 9.14.28
 - Pedestrian Walkways, 9.14.10
 - Plumbing, 9.14.24
 - Pre-Fire Plan, 9.14.9, A.9.14.9
 - Protection System Impairments, 9.14.12
 - Roofing, 9.14.26
 - Liquefied Petroleum Gas (LPG), 9.14.26.2
 - Tar Kettles, 9.14.26.1
 - Security, 9.14.11, A.9.14.11
 - Separation of Construction Areas, 9.14.14
 - Environmental Conditions, 9.14.14.5
 - Smoking, 9.14.17
 - Supervision During Construction, 9.14.6
 - Temporary Heating Equipment, 9.14.25
 - Welding, Cutting, and Other Hot Work Operations, 9.14.23
 - Prescriptive-Based Option, 9.12, A.9.12
 - Alarm Monitoring, 9.12.12
 - Alternative Fire Suppression Systems, 9.12.14
 - Alternatives, 9.12.3, A.9.12.3
 - Automatic Fire Sprinkler Systems, 9.12.13, A.9.12.13
 - Corrosion Protection, 9.12.13.3, A.9.12.13.3
 - CPVC Pipe, 9.12.13.4
 - Collection Storage Rooms, 9.12.24
 - Book Stacks, 9.12.24.8, A.9.12.24.8
 - Compact Storage, 9.12.24.4, A.9.12.24.4
 - Fire Suppression System, 9.12.24.4.1
 - System Design, 9.12.24.4.1.4
 - Construction, 9.12.24.1
 - Emergency Lighting, 9.12.24.2
 - Fire Protection, 9.12.24.3
 - Secondary Storage Facilities, 9.12.24.10
 - Powered Industrial Trucks, 9.12.24.10.2
 - Vertical Shelf Barriers, 9.12.24.10.1
 - Security, 9.12.24.9
 - Smoke Control, 9.12.24.6, A.9.12.24.6
 - Utilities, 9.12.24.5
 - Wet Collections, 9.12.24.7
 - Compensatory Features, 9.12.6, A.9.12.6
 - Electronic Premises Security Systems, 9.12.11
 - Emergency Power, 9.12.19
 - Equivalency, 9.12.4, A.9.12.4
 - Exhibit Design and Construction, 9.12.25, A.9.12.25
 - Electrical Requirements, 9.12.25.4
 - Exhibit Cases, 9.12.25.2
 - Exhibit Materials, 9.12.25.3
 - Fire Protection, 9.12.25.5
 - Protection Plan, 9.12.25.1
 - Fire Detection and Alarm Systems, 9.12.10, A.9.12.10
 - Fire Spread Control, 9.12.8
 - Hazardous Areas, 9.12.20, A.9.12.20
 - Hazardous Areas, 9.12.26
 - General, 9.12.26.1
 - Laboratories, 9.12.26.3, A.9.12.26.3
 - Painting, 9.12.26.2, A.9.12.26.2
 - Interior Finishes, 9.12.21
 - Lightning Protection, 9.12.22, A.9.12.22
 - Location, 9.12.23
 - Materials, 9.12.7
 - Limited-Combustible Material, 9.12.7.2
 - Noncombustible Material, 9.12.7.1
 - Modifications of Requirements, 9.12.5, A.9.12.5
 - Portable Fire Extinguishers, 9.12.16, A.9.12.16
 - Protection Systems, 9.12.9, A.9.12.9
 - Existing Protection Systems, 9.12.9.1
 - New Construction, 9.12.9.2
 - Public Areas, 9.12.27
 - Roof Coverings, 9.12.18
 - Standpipe and Hose Systems, 9.12.15, A.9.12.15
 - Testing of Integrated Systems, 9.12.17, A.9.12.17
- Prioritization of Significant Elements, Collections, and Operations, 9.6
- Project Team, 9.3, A.9.3
- Survey, 9.4, A.9.4

- Collections, 9.4.2
 - Structure, 9.4.1
 - Exterior, 9.4.1.1, A.9.4.1.1
 - Interior, 9.4.1.2, A.9.4.1.2
 - Vulnerability Assessment and Evaluation, 9.8
 - Noncombustible Material**
 - Definition, 3.3.51
 - Notification Appliance**
 - Definition, 3.3.52
- O-
- Objective**
 - Definition, 3.3.53
 - Occupancy**
 - Definition, 3.3.54
 - Occupant Characteristics**
 - Definition, 3.3.55
 - Occupant Load**
 - Definition, 3.3.56
- P-
- Performance Criteria**
 - Definition, 3.3.58
 - Performance-Based Design Approach**
 - Definition, 3.3.57
 - Place of Worship**
 - Definition, 3.3.59
 - Places of Worship**, Chap. 15
 - Candles and Censers, 15.8
 - Fire Prevention, 15.6
 - Draperies and Decorations, 15.6.1
 - Housekeeping, 15.6.2, A.15.6.2
 - Fire Protection Systems, 15.7
 - General, 15.1
 - Historical Records and Artifacts, 15.9
 - Occupant Loading, 15.4
 - Protection Plan, 15.3
 - Responsibility, 15.2
 - Special Facilities, 15.10
 - Artifacts and Museum/Exhibit Areas, 15.10.6
 - Homeless Shelters, 15.10.3, A.15.10.3
 - Kitchens, 15.10.1
 - Commercial Cooking Appliances, 15.10.1.3
 - Kitchen Maintenance, 15.10.1.1
 - Residential Cooking Appliances, 15.10.1.2
 - Libraries, 15.10.5
 - Sanctuaries, Auditoriums, and Gymnasiums, 15.10.4, A.15.10.4
 - Schools, 15.10.2
 - Training, 15.5
 - Plenum**
 - Definition, 3.3.60
 - Preservation**
 - Definition, 3.3.61
 - Private**
 - Definition, 3.3.62
- Project Team**
 - Definition, 3.3.63
 - Proposed Design**
 - Definition, 3.3.64
 - Protected Premises**
 - Definition, 3.3.65
 - Protection**
 - Definition, 3.3.66
 - Protection Plan**, Chap. 5
 - General, 5.1, A.5.1
 - Planning Process, 5.3
 - Collect Information, 5.3.3
 - Codes, Standards, and Regulations, 5.3.3.1
 - Survey, 5.3.3.2, A.5.3.3.2
 - Collections, 5.3.3.2.2
 - Operations, 5.3.3.2.3
 - Structure, 5.3.3.2.1
 - Exterior, 5.3.3.2.1.1, A.5.3.3.2.1.1
 - Interior, 5.3.3.2.1.2, A.5.3.3.2.1.2
 - General, 5.3.1
 - Loss Scenarios, 5.3.7, A.5.3.7
 - Planning Team, 5.3.2
 - Potential Threat Identification, 5.3.5, A.5.3.5
 - Prioritization of Significant Elements, Collections, and Operations, 5.3.4
 - Risk Analysis, 5.3.8
 - Tolerability Evaluation, 5.3.6, A.5.3.6
 - Protection Plan Components, 5.4
 - Protection Plan Evaluation, 5.5
 - Responsibilities of Governing Body, 5.2
 - Organization, 5.2.8, A.5.2.8
- Protection Plan — Emergency Operations**, Chap. 6
 - Contents, 6.2
 - Continuity of Essential Building Systems, 6.4
 - Damage Limitation, 6.8
 - Assessment of Damage, 6.8.8
 - Collections Assessment, 6.8.8.1, A.6.8.8.1
 - Documentation, 6.8.8.2, A.6.8.8.2
 - Collection Inventory, 6.8.1
 - Collection Vulnerability, 6.8.2, A.6.8.2
 - Identification of Storage, 6.8.10, A.6.8.10
 - Liaison with Incident Commander, 6.8.7, A.6.8.7
 - Limitation of Damage, 6.8.11
 - Building Stabilization, 6.8.11.1
 - Collections Stabilization, 6.8.11.2, A.6.8.11.2
 - Notification of Incident, 6.8.5
 - Post-Emergency Evaluation and Documentation, 6.8.13, A.6.8.13
 - Preparation for Incidents, 6.8.3
 - Resource Allocation and Funding, 6.8.3.4, A.6.8.3.4
 - Prevention of Event, 6.8.4
 - Routine Inspection of Collection Areas, 6.8.4.3
 - Recovery from Incident, 6.8.12, A.6.8.12
 - Response Roles, 6.8.9, A.6.8.9
 - Verification of Incident, 6.8.6, A.6.8.6
- Developing Emergency Operations Procedures, 6.1

- Developing Procedures for Removal or Relocation of Collections, 6.7
 - Emergency Operations, 6.13
 - Emergency Response Activities, 6.6, A.6.6
 - Identification of Emergency Response Personnel, 6.3
 - Occupant Management, 6.5
 - Operational Recovery, 6.11
 - Public Affairs, 6.10
 - Security, 6.9
 - Staff Training, 6.12
 - Exercises, 6.12.3
 - Protection Plan — Fire Safety Management**, Chap. 7
 - Documentation, 7.4
 - Fire Safety Management, 7.2, A.7.2
 - General, 7.2.1, A.7.2.1
 - Fire Safety Manager, 7.3, A.7.3
 - Training, 7.5
 - Vulnerability Assessment, 7.1
 - Protection Plan — Security**, Chap. 8
 - Construction Areas, 8.4
 - Security Component of Protection Plan, 8.2, A.8.2
 - Security Program, 8.3
 - Access Control, 8.3.2, A.8.3.2
 - Electronic Premises Security Systems, 8.3.4
 - Parcel Control, 8.3.3
 - Physical Security Devices, 8.3.5, A.8.3.5
 - Access-Controlled Egress Door Assemblies, 8.3.5.3
 - Delayed Egress Locking Systems, 8.3.5.2
 - Installation and Maintenance, 8.3.5.1
 - Pre-Employment Screening, 8.3.1, A.8.3.1
 - Vacant Areas, 8.5, A.8.5
 - Vulnerability Assessment, 8.1
 - Public**
 - Definition, 3.3.67
- R-
- Referenced Publications**, Chap. 2
 - Rehabilitation**
 - Definition, 3.3.68
 - Renovation**
 - Definition, 3.3.69
 - Resources for Protection of Cultural Resource Property Projects**, Annex E
 - Introduction, E.1
 - NFPA, E.2
 - NICET, E.4
 - SFPE, E.3
 - UL, E.5
 - Restoration**
 - Definition, 3.3.70
 - Risk**
 - Definition, 3.3.71
- S-
- Safety Factor**
 - Definition, 3.3.72
 - Safety Margin**
 - Definition, 3.3.73
 - Salvage of Water-Damaged Library Materials**, Annex K
 - Sample Ordinance Adopting NFPA 909**, Annex F
 - Scenario**
 - Definition, 3.3.74
 - Design Fire Scenario
 - Definition, 3.3.74.1
 - Fire Scenario
 - Definition, 3.3.74.2, A.3.3.74.2
 - Secondary Storage**
 - Definition, 3.3.75
 - Security**
 - Definition, 3.3.76
 - Security Manager**
 - Definition, 3.3.77
 - Security Systems**, Annex D
 - Access Control, D.3
 - Introduction, D.1
 - Intrusion Detection, D.2
 - Exterior Detection, D.2.1
 - Interior Detection, D.2.2
 - UL Certification, D.2.3
 - Video Surveillance (CCTV), D.4
 - Depth of Field, D.4.3
 - Field of View, D.4.1
 - Lenses, D.4.2
 - Recording, D.4.4
 - Shall**
 - Definition, 3.2.5
 - Should**
 - Definition, 3.2.6
 - Smoke Detector**
 - Definition, 3.3.78
 - Special Event**
 - Definition, 3.3.79, A.3.3.79
 - Special Events**, Chap. 13
 - Access Control, 13.9
 - Combustibles, 13.7
 - Cooking Equipment, 13.4
 - Electrical Equipment, 13.8
 - Fireworks, 13.6
 - General, 13.1, A.13.1
 - Means of Egress, 13.3
 - Occupant Loading, 13.2
 - Smoking, 13.5
 - Sprinkler System**
 - Definition, 3.3.80
 - Stakeholder**
 - Definition, 3.3.81
 - Standard**
 - Definition, 3.2.7
 - Structure**
 - Definition, 3.3.82
 - System**
 - Combination System (as related to premises security)
 - Definition, 3.3.83.1

Definition, 3.3.83		-U-
Electronic Premises Security System	Utilities	
Definition, 3.3.83.2	Definition, 3.3.84, A.3.3.84	
Fire Alarm System		
Definition, 3.3.83.3		-V-
Fire Protection System	Verification Method	
Definition, 3.3.83.4	Definition, 3.3.85	
Sprinkler System	Vertical Opening	
Definition, 3.3.83.5	Definition, 3.3.86	

Sequence of Events for the Standards Development Process

Once the current edition is published, a Standard is opened for Public Input.

Step 1 – Input Stage

- Input accepted from the public or other committees for consideration to develop the First Draft
- Technical Committee holds First Draft Meeting to revise Standard (23 weeks); Technical Committee(s) with Correlating Committee (10 weeks)
- Technical Committee ballots on First Draft (12 weeks); Technical Committee(s) with Correlating Committee (11 weeks)
- Correlating Committee First Draft Meeting (9 weeks)
- Correlating Committee ballots on First Draft (5 weeks)
- First Draft Report posted on the document information page

Step 2 – Comment Stage

- Public Comments accepted on First Draft (10 weeks) following posting of First Draft Report
- If Standard does not receive Public Comments and the Technical Committee chooses not to hold a Second Draft meeting, the Standard becomes a Consent Standard and is sent directly to the Standards Council for issuance (see Step 4) or
- Technical Committee holds Second Draft Meeting (21 weeks); Technical Committee(s) with Correlating Committee (7 weeks)
- Technical Committee ballots on Second Draft (11 weeks); Technical Committee(s) with Correlating Committee (10 weeks)
- Correlating Committee Second Draft Meeting (9 weeks)
- Correlating Committee ballots on Second Draft (8 weeks)
- Second Draft Report posted on the document information page

Step 3 – NFPA Technical Meeting

- Notice of Intent to Make a Motion (NITMAM) accepted (5 weeks) following the posting of Second Draft Report
- NITMAMs are reviewed and valid motions are certified by the Motions Committee for presentation at the NFPA Technical Meeting
- NFPA membership meets each June at the NFPA Technical Meeting to act on Standards with “Certified Amending Motions” (certified NITMAMs)
- Committee(s) vote on any successful amendments to the Technical Committee Reports made by the NFPA membership at the NFPA Technical Meeting

Step 4 – Council Appeals and Issuance of Standard

- Notification of intent to file an appeal to the Standards Council on Technical Meeting action must be filed within 20 days of the NFPA Technical Meeting
- Standards Council decides, based on all evidence, whether to issue the standard or to take other action

Notes:

1. Time periods are approximate; refer to published schedules for actual dates.
2. Annual revision cycle documents with certified amending motions take approximately 101 weeks to complete.
3. Fall revision cycle documents receiving certified amending motions take approximately 141 weeks to complete.

Committee Membership Classifications^{1,2,3,4}

The following classifications apply to Committee members and represent their principal interest in the activity of the Committee.

1. M *Manufacturer*: A representative of a maker or marketer of a product, assembly, or system, or portion thereof, that is affected by the standard.
2. U *User*: A representative of an entity that is subject to the provisions of the standard or that voluntarily uses the standard.
3. IM *Installer/Maintainer*: A representative of an entity that is in the business of installing or maintaining a product, assembly, or system affected by the standard.
4. L *Labor*: A labor representative or employee concerned with safety in the workplace.
5. RT *Applied Research/Testing Laboratory*: A representative of an independent testing laboratory or independent applied research organization that promulgates and/or enforces standards.
6. E *Enforcing Authority*: A representative of an agency or an organization that promulgates and/or enforces standards.
7. I *Insurance*: A representative of an insurance company, broker, agent, bureau, or inspection agency.
8. C *Consumer*: A person who is or represents the ultimate purchaser of a product, system, or service affected by the standard, but who is not included in (2).
9. SE *Special Expert*: A person not representing (1) through (8) and who has special expertise in the scope of the standard or portion thereof.

NOTE 1: “Standard” connotes code, standard, recommended practice, or guide.

NOTE 2: A representative includes an employee.

NOTE 3: While these classifications will be used by the Standards Council to achieve a balance for Technical Committees, the Standards Council may determine that new classifications of member or unique interests need representation in order to foster the best possible Committee deliberations on any project. In this connection, the Standards Council may make such appointments as it deems appropriate in the public interest, such as the classification of “Utilities” in the National Electrical Code Committee.

NOTE 4: Representatives of subsidiaries of any group are generally considered to have the same classification as the parent organization.

Submitting Public Input / Public Comment Through the Online Submission System

Soon after the current edition is published, a Standard is open for Public Input.

Before accessing the Online Submission System, you must first sign in at www.nfpa.org. *Note: You will be asked to sign-in or create a free online account with NFPA before using this system:*

- a. Click on Sign In at the upper right side of the page.
- b. Under the Codes and Standards heading, click on the “List of NFPA Codes & Standards,” and then select your document from the list or use one of the search features.

OR

- a. Go directly to your specific document information page by typing the convenient shortcut link of www.nfpa.org/document# (Example: NFPA 921 would be www.nfpa.org/921). Sign in at the upper right side of the page.

To begin your Public Input, select the link “The next edition of this standard is now open for Public Input” located on the About tab, Current & Prior Editions tab, and the Next Edition tab. Alternatively, the Next Edition tab includes a link to Submit Public Input online.

At this point, the NFPA Standards Development Site will open showing details for the document you have selected. This “Document Home” page site includes an explanatory introduction, information on the current document phase and closing date, a left-hand navigation panel that includes useful links, a document Table of Contents, and icons at the top you can click for Help when using the site. The Help icons and navigation panel will be visible except when you are actually in the process of creating a Public Input.

Once the First Draft Report becomes available there is a Public Comment period during which anyone may submit a Public Comment on the First Draft. Any objections or further related changes to the content of the First Draft must be submitted at the Comment stage.

To submit a Public Comment you may access the online submission system utilizing the same steps as previously explained for the submission of Public Input.

For further information on submitting public input and public comments, go to: <http://www.nfpa.org/publicinput>.

Other Resources Available on the Document Information Pages

About tab: View general document and subject-related information.

Current & Prior Editions tab: Research current and previous edition information on a Standard.

Next Edition tab: Follow the committee’s progress in the processing of a Standard in its next revision cycle.

Technical Committee tab: View current committee member rosters or apply to a committee.

Technical Questions tab: For members and Public Sector Officials/AHJs to submit questions about codes and standards to NFPA staff. Our Technical Questions Service provides a convenient way to receive timely and consistent technical assistance when you need to know more about NFPA codes and standards relevant to your work. Responses are provided by NFPA staff on an informal basis.

Products & Training tab: List of NFPA’s publications and training available for purchase.

Information on the NFPA Standards Development Process

I. Applicable Regulations. The primary rules governing the processing of NFPA standards (codes, standards, recommended practices, and guides) are the NFPA *Regulations Governing the Development of NFPA Standards (Regs)*. Other applicable rules include NFPA *Bylaws*, NFPA *Technical Meeting Convention Rules*, NFPA *Guide for the Conduct of Participants in the NFPA Standards Development Process*, and the NFPA *Regulations Governing Petitions to the Board of Directors from Decisions of the Standards Council*. Most of these rules and regulations are contained in the *NFPA Standards Directory*. For copies of the *Directory*, contact Codes and Standards Administration at NFPA Headquarters; all these documents are also available on the NFPA website at “www.nfpa.org.”

The following is general information on the NFPA process. All participants, however, should refer to the actual rules and regulations for a full understanding of this process and for the criteria that govern participation.

II. Technical Committee Report. The Technical Committee Report is defined as “the Report of the responsible Committee(s), in accordance with the Regulations, in preparation of a new or revised NFPA Standard.” The Technical Committee Report is in two parts and consists of the First Draft Report and the Second Draft Report. (See *Regs* at Section 1.4.)

III. Step 1: First Draft Report. The First Draft Report is defined as “Part one of the Technical Committee Report, which documents the Input Stage.” The First Draft Report consists of the First Draft, Public Input, Committee Input, Committee and Correlating Committee Statements, Correlating Notes, and Ballot Statements. (See *Regs* at 4.2.5.2 and Section 4.3.) Any objection to an action in the First Draft Report must be raised through the filing of an appropriate Comment for consideration in the Second Draft Report or the objection will be considered resolved. [See *Regs* at 4.3.1(b).]

IV. Step 2: Second Draft Report. The Second Draft Report is defined as “Part two of the Technical Committee Report, which documents the Comment Stage.” The Second Draft Report consists of the Second Draft, Public Comments with corresponding Committee Actions and Committee Statements, Correlating Notes and their respective Committee Statements, Committee Comments, Correlating Revisions, and Ballot Statements. (See *Regs* at 4.2.5.2 and Section 4.4.) The First Draft Report and the Second Draft Report together constitute the Technical Committee Report. Any outstanding objection following the Second Draft Report must be raised through an appropriate Amending Motion at the NFPA Technical Meeting or the objection will be considered resolved. [See *Regs* at 4.4.1(b).]

V. Step 3a: Action at NFPA Technical Meeting. Following the publication of the Second Draft Report, there is a period during which those wishing to make proper Amending Motions on the Technical Committee Reports must signal their intention by submitting a Notice of Intent to Make a Motion (NITMAM). (See *Regs* at 4.5.2.) Standards that receive notice of proper Amending Motions (Certified Amending Motions) will be presented for action at the annual June NFPA Technical Meeting. At the meeting, the NFPA membership can consider and act on these Certified Amending Motions as well as Follow-up Amending Motions, that is, motions that become necessary as a result of a previous successful Amending Motion. (See 4.5.3.2 through 4.5.3.6 and Table 1, Columns 1-3 of *Regs* for a summary of the available Amending Motions and who may make them.) Any outstanding objection following action at an NFPA Technical Meeting (and any further Technical Committee consideration following successful Amending Motions, see *Regs* at 4.5.3.7 through 4.6.5.3) must be raised through an appeal to the Standards Council or it will be considered to be resolved.

VI. Step 3b: Documents Forwarded Directly to the Council. Where no NITMAM is received and certified in accordance with the Technical Meeting Convention Rules, the standard is forwarded directly to the Standards Council for action on issuance. Objections are deemed to be resolved for these documents. (See *Regs* at 4.5.2.5.)

VII. Step 4a: Council Appeals. Anyone can appeal to the Standards Council concerning procedural or substantive matters related to the development, content, or issuance of any document of the NFPA or on matters within the purview of the authority of the Council, as established by the Bylaws and as determined by the Board of Directors. Such appeals must be in written form and filed with the Secretary of the Standards Council (see *Regs* at Section 1.6). Time constraints for filing an appeal must be in accordance with 1.6.2 of the *Regs*. Objections are deemed to be resolved if not pursued at this level.

VIII. Step 4b: Document Issuance. The Standards Council is the issuer of all documents (see Article 8 of *Bylaws*). The Council acts on the issuance of a document presented for action at an NFPA Technical Meeting within 75 days from the date of the recommendation from the NFPA Technical Meeting, unless this period is extended by the Council (see *Regs* at 4.7.2). For documents forwarded directly to the Standards Council, the Council acts on the issuance of the document at its next scheduled meeting, or at such other meeting as the Council may determine (see *Regs* at 4.5.2.5 and 4.7.4).

IX. Petitions to the Board of Directors. The Standards Council has been delegated the responsibility for the administration of the codes and standards development process and the issuance of documents. However, where extraordinary circumstances requiring the intervention of the Board of Directors exist, the Board of Directors may take any action necessary to fulfill its obligations to preserve the integrity of the codes and standards development process and to protect the interests of the NFPA. The rules for petitioning the Board of Directors can be found in the *Regulations Governing Petitions to the Board of Directors from Decisions of the Standards Council* and in Section 1.7 of the *Regs*.

X. For More Information. The program for the NFPA Technical Meeting (as well as the NFPA website as information becomes available) should be consulted for the date on which each report scheduled for consideration at the meeting will be presented. To view the First Draft Report and Second Draft Report as well as information on NFPA rules and for up-to-date information on schedules and deadlines for processing NFPA documents, check the NFPA website (www.nfpa.org/docinfo) or contact NFPA Codes & Standards Administration at (617) 984-7246.



Xchange™

An online community that connects you with peers worldwide and directly with NFPA staff

Have a question about the code or standard you're reading now? NFPA Xchange™ can help!

NFPA Xchange™ is our free online community, and we want to invite you to join us there! NFPA Xchange lets you connect with professionals worldwide, explore content, share ideas, and ask questions, as the latest way to stay up-to-date on codes- and standards-related information. Plus you can:

- ▶ ASK your peers
- ▶ SEARCH questions & answers
- ▶ READ NFPA blogs

NFPA Members also enjoy exclusive access to the 'Members Only' section on NFPA Xchange, where you can submit technical standards questions* directly to NFPA staff or search questions that have already been submitted by others!

Join NFPA Xchange TODAY – IT'S FREE AND EASY!

1	2	3
Go online	Enter	YOU'RE IN!
NFPA.ORG/Xchange	YOUR NFPA ID# OR EMAIL ADDRESS AND PASSWORD	

Search. Share. Xchange Ideas. Get Involved Today!

*For the full terms of use, please visit nfpa.org/standard_items/terms-of-use#xchange. NFPA® is a registered trademark of the National Fire Protection Association, Quincy, MA 02169.