

Specification for Wellhead and Tree Equipment

API SPECIFICATION 6A
TWENTY-FIRST EDITION, NOVEMBER 2018

API MONOGRAM PROGRAM EFFECTIVE DATE: NOVEMBER 2019

ERRATA 1, APRIL 2019
ERRATA 2, JUNE 2020
ADDENDUM 1, JULY 2020



Special Notes

API publications necessarily address problems of a general nature. With respect to particular circumstances, local, state, and federal laws and regulations should be reviewed.

Neither API nor any of API's employees, subcontractors, consultants, committees, or other assignees make any warranty or representation, either express or implied, with respect to the accuracy, completeness, or usefulness of the information contained herein, or assume any liability or responsibility for any use, or the results of such use, of any information or process disclosed in this publication. Neither API nor any of API's employees, subcontractors, consultants, or other assignees represent that use of this publication would not infringe upon privately owned rights.

API publications may be used by anyone desiring to do so. Every effort has been made by the Institute to ensure the accuracy and reliability of the data contained in them; however, the Institute makes no representation, warranty, or guarantee in connection with this publication and hereby expressly disclaims any liability or responsibility for loss or damage resulting from its use or for the violation of any authorities having jurisdiction with which this publication may conflict.

API publications are published to facilitate the broad availability of proven, sound engineering and operating practices. These publications are not intended to obviate the need for applying sound engineering judgment regarding when and where these publications should be used. The formulation and publication of API publications is not intended in any way to inhibit anyone from using any other practices.

Users of this specification should not rely exclusively on the information contained in this document. Sound business, scientific, engineering, and safety judgment should be used in employing the information contained herein.

Any manufacturer marking equipment or materials in conformance with the marking requirements of an API standard is solely responsible for conforming to all the applicable requirements of that standard. API does not represent, warrant, or guarantee that such products do in fact conform to the applicable API standard.

All rights reserved. No part of this work may be reproduced, translated, stored in a retrieval system, or transmitted by any means, electronic, mechanical, photocopying, recording, or otherwise, without prior written permission from the publisher. Contact the publisher, API Publishing Services, 200 Massachusetts Avenue, NW, Suite 1100, Washington, DC 20001.

Copyright © 2018 American Petroleum Institute

Foreword

Nothing contained in any API publication is to be construed as granting any right, by implication or otherwise, for the manufacture, sale, or use of any method, apparatus, or product covered by letters patent. Neither should anything contained in the publication be construed as insuring anyone against liability for infringement of letters patent.

The verbal forms used to express the provisions in this specification are as follows:

- the term “shall” denotes a minimum requirement in order to conform to the standard;
- the term “should” denotes a recommendation or that which is advised but not required in order to conform to the standard;
- the term “may” is used to express permission or a provision that is optional;
- the term “can” is used to express possibility or capability.

This document was produced under API standardization procedures that ensure appropriate notification and participation in the developmental process and is designated as an API standard. Questions concerning the interpretation of the content of this publication or comments and questions concerning the procedures under which this publication was developed should be directed in writing to the Director of Standards, American Petroleum Institute, 200 Massachusetts Avenue, NW, Suite 1100, Washington, DC 20001. Requests for permission to reproduce or translate all or any part of the material published herein should also be addressed to the director.

For API Monogram Program licensees and APIQR Program registrants, this standard shall become effective on the program date printed on the cover but may be used voluntarily from the date of publication.

Generally, API standards are reviewed and revised, reaffirmed, or withdrawn at least every 5 years. A one-time extension of up to 2 years may be added to this review cycle. Status of the publication can be ascertained from the API Standards Department, telephone (202) 682-8000. A catalog of API publications and materials is published annually by API, 200 Massachusetts Avenue, NW, Suite 1100, Washington, DC 20001.

Suggested revisions are invited and should be submitted to the Standards Department, API, 200 Massachusetts Avenue, NW, Suite 1100, Washington, DC 20001, standards@api.org.

Contents

1	Scope.....	1
2	Normative References	1
3	Terms, Definitions, Abbreviated Terms, and Symbols.....	4
3.1	Terms and Definitions.....	4
3.2	Abbreviated Terms.....	15
3.3	Symbols.....	16
4	Application and Performance	17
4.1	Applicability	17
4.2	Performance Requirements—General	22
4.3	Service Conditions.....	22
4.3.1	Pressure Ratings.....	22
4.3.2	Temperature Ratings	23
4.3.3	Material Classes	23
4.3.4	Product Specification Level.....	25
5	Design.....	26
5.1	Design Methods.....	26
5.1.1	End and Outlet Connectors.....	26
5.1.2	Hangers, Back-pressure Valves, Lock Screws, and Stems.....	27
5.1.3	Bodies, Bonnets, and Other End Connectors.....	27
5.1.4	Other Parts.....	28
5.1.5	Equipment-specific Requirements	28
5.2	Design Tolerances	28
5.3	Design Documentation	28
5.4	Design Review and Verification.....	28
5.5	Design Validation	28
6	Materials	28
6.1	General	28
6.2	Written Specifications.....	29
6.2.1	Applicability	29
6.2.2	Metallic Requirements	29
6.2.3	Nonmetallic Requirements.....	29
6.3	Bodies, Bonnets, and End and Outlet Connectors.....	30
6.3.1	Materials.....	30
6.3.2	Material Qualification Testing	31
6.3.3	Processing	33
6.3.4	Heat-treating	33
6.3.5	Chemical Composition	34
6.4	Qualification Test Coupons.....	35
6.4.1	General	35
6.4.2	Equivalent Round.....	36
6.4.3	Processing.....	38
6.4.4	Material Qualification	39
6.5	Production Heat-treating Equipment	40
6.5.1	General	40
6.5.2	Instrument Accuracy.....	40
6.5.3	Instrument Calibration.....	40
6.5.4	Production Type Equipment—Batch-type Furnaces.....	40
6.5.5	Production Type Equipment—Continuous-type Furnaces	41
7	Welding.....	41
7.1	General	41

7.2	Nonpressure-containing Welds Other Than Weld Overlays.....	41
7.2.1	Welding Procedure/Performance	41
7.2.2	Application.....	42
7.3	Pressure-containing Fabrication Welds	42
7.3.1	General	42
7.3.2	Joint Design.....	42
7.3.3	Materials.....	42
7.3.4	Welding Procedure Qualifications.....	42
7.3.5	Welder Performance Qualification	44
7.3.6	Welding Requirements	44
7.3.7	Post-weld Heat-treatment.....	45
7.3.8	Welding Controls.....	45
7.4	Pressure-containing Repair Welds.....	46
7.4.1	General	46
7.4.2	Welding Procedure Qualifications.....	46
7.4.3	Weld Repair of Castings	46
7.4.4	Bolt Hole, Tapped Hole, and Machined Blind Hole Repair.....	46
7.5	Weld Overlay.....	47
7.5.1	Corrosion-resistant Overlay (Including Ring Grooves)	47
7.5.2	Weld Overlay for Other Than Corrosion Resistance	49
7.5.3	Repair of Weld Overlays	49
8	Bolting	50
8.1	Closure Bolting.....	50
8.1.1	Tensile Stress	50
8.1.2	Quality	50
8.1.3	Studded Outlet Connection.....	50
8.1.4	Closure Bolting Records	50
8.1.5	Closure Bolting Marking.....	51
8.1.6	Impact Test Marking.....	51
8.2	Closure Bolting for Flanged and Studded End and Outlet Connectors	51
8.2.1	General	51
8.2.2	Design.....	51
8.2.3	Materials.....	51
8.3	Other Closure Bolting	54
8.3.1	General	54
8.3.2	Design.....	54
8.3.3	Materials.....	54
8.3.4	Quality	55
9	Packing Mechanisms, Pressure Boundary Penetrations, and Ports.....	55
9.1	Packing Mechanisms	55
9.1.1	Performance Requirements	55
9.1.2	Design.....	55
9.2	Fittings and Pressure Boundary Penetrations.....	55
9.2.1	General	55
9.2.2	Performance Requirements	55
9.2.3	Design.....	55
9.2.4	Materials.....	56
9.2.5	Marking.....	56
9.2.6	Storing and Shipping	56
9.2.7	Testing.....	56
9.2.8	Quality Requirements	56
9.3	Test, Gauge, Vent, and Injection Connector Ports	56
9.3.1	Sealing.....	56
9.3.2	Vent and Injection Connector Ports	56
9.3.3	Test and Gauge Connector Ports	56

10	Quality Control	58
10.1	Application	58
10.2	Measuring and Testing Equipment	58
10.2.1	General	58
10.2.2	Pressure-measuring Devices	59
10.3	Personnel Qualifications	59
10.3.1	Nondestructive Examination Personnel	59
10.3.2	Visual Examination Personnel	59
10.3.3	Welding Inspectors	60
10.3.4	Other Personnel	60
10.4	Requirements	60
10.4.1	General	60
10.4.2	Bodies, Bonnets, End and Outlet Connectors, and Clamp Hub End Connectors.....	60
10.4.3	Stems.....	73
10.4.4	Valve Bore Sealing Mechanisms and Choke Trim.....	74
10.4.5	Ring Gaskets and Nonintegral Metal Seals	74
10.4.6	Nonmetallic Seals.....	77
10.4.7	Assembled Equipment—General	78
10.4.8	Mandrel-type Hangers.....	79
10.4.9	Slip-type Hangers.....	83
10.4.10	Bullplugs, Valve-removal Plugs, Back-pressure Valves, and Fittings	84
11	Factory Acceptance Testing	85
11.1	General	85
11.1.1	Scope and Applicability	85
11.1.2	Measurement, Monitoring, and Recording Equipment	87
11.1.3	Test Sequence	87
11.1.4	Leak Detection	87
11.2	Hydrostatic Testing.....	87
11.2.1	Hydrostatic Testing—General Requirements.....	87
11.2.2	Hydrostatic Test Acceptance Criteria	88
11.2.3	Hydrostatic Shell Test.....	88
11.2.4	Hydrostatic Seat Tests and Functional Tests—Valves	90
11.2.5	Conditional Hydrostatic Body Test—PSL 1, PSL 2, and PSL 3	91
11.2.6	Hydrostatic Testing of Back-pressure Valves	92
11.3	Gas Testing—PSL 3G and PSL 4	92
11.3.1	Gas Testing—General Requirements.....	92
11.3.2	Gas Test Acceptance Criteria—General Requirements	93
11.3.3	Gas Body Test	93
11.3.4	Gas Seat Test—Valves.....	93
11.3.5	Gas Backseat Test—Gate Valves	94
11.3.6	Conditional Gas Body Test	95
11.4	Drift Testing	96
11.4.1	Full-bore Valves.....	96
11.4.2	Valves with Nonstandard Bore Sizes	96
11.4.3	Tree Assemblies	97
12	Equipment Marking	97
12.1	Marking Requirements.....	97
12.2	Marking Method	97
12.3	Nameplates	97
12.4	Hidden Marking	97
12.5	Thread Marking.....	98
12.6	Size Marking	99
12.7	Temperature Marking.....	99
12.8	Hardness Tests.....	99
12.9	Ring Grooves	99

12.10	Clamp Hub End Connectors.....	99
13	Storing and Shipping	99
13.1	Draining after Testing	99
13.2	Corrosion Protection	99
13.3	Sealing-surface Protection.....	100
13.4	Assembly and Maintenance Instructions	100
13.5	Ring Gaskets	100
13.6	Age Control and Storage of Nonmetallic Seals.....	100
14	Equipment-specific Requirements	100
14.1	Integral, Blind, and Test Flanges	100
14.1.1	General Application	100
14.1.2	Design.....	101
14.1.3	Materials	105
14.1.4	Quality Control/Testing.....	105
14.1.5	Marking.....	105
14.1.6	Storing and Shipping	106
14.2	Ring Gaskets	106
14.2.1	General	106
14.2.2	Design.....	106
14.2.3	Materials	106
14.2.4	Quality Control/Testing.....	108
14.2.5	Marking.....	108
14.2.6	Storing and Shipping	108
14.3	Threaded Connectors	108
14.3.1	General	108
14.3.2	Design.....	108
14.3.3	Materials	109
14.3.4	Quality Control/Testing.....	109
14.3.5	Marking.....	109
14.3.6	Storing and Shipping	109
14.4	Tees and Crosses.....	109
14.4.1	General	109
14.4.2	Design.....	109
14.4.3	Materials	110
14.4.4	Quality Control/Testing.....	110
14.4.5	Marking.....	110
14.4.6	Storing and Shipping	110
14.5	Bullplugs	111
14.5.1	General	111
14.5.2	Design.....	111
14.5.3	Materials	111
14.5.4	Quality Control/Testing.....	112
14.5.5	Marking.....	112
14.5.6	Storing and Shipping	112
14.6	Valve-removal Plugs	112
14.6.1	General	112
14.6.2	Design.....	112
14.6.3	Materials	113
14.6.4	Quality Control/Thread Gauging.....	113
14.6.5	Marking.....	113
14.6.6	Storing and Shipping	113
14.7	Top Connectors	114
14.7.1	General	114
14.7.2	Design.....	114
14.7.3	Materials	114

14.7.4	Quality Control/Testing/Welding	114
14.7.5	Marking.....	115
14.7.6	Storage and Shipping	115
14.8	Crossover Connectors.....	115
14.8.1	General	115
14.8.2	Design.....	119
14.8.3	Materials	120
14.8.4	Quality Control/Testing.....	120
14.8.5	Marking.....	120
14.8.6	Storing and Shipping	120
14.9	Other End Connectors	120
14.9.1	General	120
14.9.2	Design.....	120
14.9.3	Materials	121
14.9.4	Quality Control/Testing.....	121
14.9.5	Marking.....	121
14.9.6	Storing and Shipping	121
14.10	Spools (Adapter and Spacer).....	121
14.10.1	General	121
14.10.2	Design.....	121
14.10.3	Materials	122
14.10.4	Quality Control/Testing.....	122
14.10.5	Marking.....	122
14.10.6	Storing and Shipping	122
14.11	Valves	122
14.11.1	General	122
14.11.2	Design.....	126
14.11.3	Materials	128
14.11.4	Quality Control/Testing.....	129
14.11.5	Marking.....	129
14.11.6	Storing and Shipping	130
14.12	Back-pressure Valves	130
14.12.1	General	130
14.12.2	Design.....	130
14.12.3	Materials	131
14.12.4	Quality Control/Testing.....	131
14.12.5	Marking.....	131
14.12.6	Storing and Shipping	131
14.13	Casing and Tubing Hangers (Slip- and Mandrel-type)	131
14.13.1	General	131
14.13.2	Design.....	131
14.13.3	Materials	135
14.13.4	Quality Control/Testing.....	137
14.13.5	Marking.....	137
14.13.6	Storing and Shipping	138
14.14	Casing and Tubing Heads	139
14.14.1	General	139
14.14.2	Design.....	139
14.14.3	Materials	143
14.14.4	Quality Control/Testing.....	143
14.14.5	Marking.....	143
14.14.6	Storing and Shipping	144
14.15	Chokes.....	144
14.15.1	General	144
14.15.2	Design.....	146
14.15.3	Materials	147

14.15.4	Quality Control/Testing	147
14.15.5	Marking	147
14.15.6	Storing and Shipping	148
14.16	Actuators	148
14.16.1	General	148
14.16.2	Design	148
14.16.3	Materials	149
14.16.4	Quality Control/Testing	150
14.16.5	Marking	151
14.16.6	Storage and Shipping	152
14.17	Safety Valves, Shutdown Valves, and Actuators	152
14.17.1	General	152
14.17.2	Design	152
14.17.3	Materials	155
14.17.4	Quality Control/Testing	155
14.17.5	Marking	155
14.17.6	Storage and Shipping	156
14.18	Tree Assemblies	156
14.18.1	General	156
14.18.2	Design	156
14.18.3	Materials	156
14.18.4	Quality Control/Testing/Assembly	157
14.18.5	Marking	157
14.18.6	Storing and Shipping	157
15	Records	157
15.1	General	157
15.1.1	NACE MR0175/ISO 15156 Record Requirements	157
15.1.2	Record Control	157
15.2	Records Maintained by Manufacturer	157
15.2.1	Records of Pressure Tests	157
15.2.2	Body, Bonnet, End and Outlet Connectors, Stem, Valve Bore Sealing Mechanism, Mandrel Tubing Hanger, Mandrel Casing Hanger, Slip Bowl, and Slip Segment Records	158
15.2.3	Ring Gaskets and Nonintegral Metal Seals Records	159
15.2.4	Closure Bolting Records	159
15.2.5	Nonmetallic Sealing Material Records	159
15.2.6	Bullplugs, Valve-removal Plugs, and Back-pressure Valve Records	160
15.2.7	Assembled Equipment Records	160
15.2.8	Choke Trim Records	160
15.3	Records Furnished to Purchaser	160
15.3.1	General	160
15.3.2	Body, Bonnet, End and Outlet Connectors, Stem, Valve Bore Sealing Mechanism, Mandrel Tubing Hanger, Casing Hanger, and Back-pressure Valve Records	161
15.3.3	Ring Gasket and Nonintegral Metal Seals Records	161
15.3.4	Closure Bolting Records	161
15.3.5	Nonmetallic Sealing Material Records	161
15.3.6	Slip Hanger Records	161
15.3.7	Assembled Equipment Records	161
15.4	SSV, USV, and BSDV Records	162
15.4.1	General	162
15.4.2	Shipping Report	162
15.4.3	Test Data Sheet	162
15.4.4	Records Furnished to Purchaser	162
15.4.5	Minimum Contents of Manufacturer's Operating Manual	164
15.4.6	Failure Reporting	164
Annex A (informative)	API Monogram Program Use of the API Monogram by Licensees	165

Annex B (informative) Purchasing Guidelines.....	169
Annex C (informative) Conversion Procedures—Units of Measure	188
Annex D (normative) Dimensional Tables—SI Units.....	192
Annex E (normative) Dimensional Tables—USC Units.....	254
Annex F (informative) Design Validation Procedures for PR2 (PR2F Level)	316
Annex G (informative) Design and Rating of Equipment for Use at Elevated Temperatures	348
Annex H (informative) Recommended Assembly of Closure Bolting	352
Annex I (informative) Recommended Bolt Lengths	357
Annex J (normative) Weld-neck Flanges	366
Annex K (informative) Top Connectors	370
Annex L (informative) Segmented Flanges	383
Annex M (normative) Heat-treat Equipment Survey.....	392
Bibliography.....	394
Figures	
Figure 1—Typical Wellhead Assembly Nomenclature	19
Figure 2—Typical Wellhead Assembly Nomenclature	20
Figure 3—Typical Tree Nomenclature.....	21
Figure 4—Equivalent Round Models.....	37
Figure 5—Test and Gauge Connector Ports for 103.5 MPa and 138.0 MPa (15,000 psi and 20,000 psi) Rated Working Pressure	57
Figure 6—Ring Gasket Hardness Test Location.....	76
Figure 7—Crossover Spool with Restricted-area Packoff Supported by the Lower Head	117
Figure 8—Crossover Spool with Restricted-area Packoff Supported by the Upper Spool.....	117
Figure 9—Multistage Crossover Spool	118
Figure 10—Crossover Adapter	118
Figure 11—Single-string and Dual-string Multiple Valve Assemblies	123
Figure 12—Regular Swing Check Valve	124
Figure 13—Full-opening Swing Check Valve	125
Figure 14—Regular Lift Check Valve	125
Figure 15—Typical Reduced-opening Vertical Bore.....	141
Figure 16—Typical Adjustable Choke.....	145
Figure 17—Typical Positive Choke	145
Figure 18—Example of a Safety Valve Shipping Report	162
Figure 19—Example of a Safety Valve Factory Acceptance Test Data Sheet.....	163
Figure B.1—Wellhead Equipment Data Sheet—General.....	170
Figure B.2—Wellhead Equipment Data Sheet—Casing-head Housing	171
Figure B.3—Wellhead Equipment Data Sheet—Casing-head Spool.....	172
Figure B.4—Wellhead Equipment Data Sheet—Tubing-head Spool.....	173
Figure B.5—Wellhead Equipment Data Sheet—Crossover Flange.....	174
Figure B.6—Wellhead Equipment Data Sheet—Tubing-head Adapter	174
Figure B.7—Wellhead Equipment Data Sheet—Tree and Choke	175
Figure B.8—Wellhead Equipment Data Sheet—Multistage Crossover Spool	176
Figure B.9—Wellhead Equipment Data Sheet—Wellhead Safety Valves	178
Figure B.10—Equipment Data Sheet—Boarding Shutdown Valves	178
Figure B.11—Wellhead Equipment Data Sheet—Choke Sizing.....	179
Figure B.12—Wellhead Equipment Data Sheet—Actuator and Bonnet.....	180
Figure B.13—Typical Wellhead and Tree Configuration for a 34.5 MPa (5000 psi) Rated Working Pressure	181

Figure B.14—Typical Wellhead and Tree Configuration for a 69.0 MPa (10,000 psi) Rated Working Pressure	182
Figure B.15—Recommended Minimum PSL for Primary Parts	184
Figure F.1—Test Procedure	321
Figure F.2—Load Cycle Testing for Hangers	337
Figure F.3—Group 2 and Group 3 Hangers	338
Figure F.4—Group 3 Hangers with Crossover Seal.....	339
Figure F.5—Pressure/Temperature Cycles for Group 3 Slip and Mandrel-type Hangers without Bottom Casing Packoff.....	341
Figure F.6—Pressure/Temperature Cycles for Group 3 Slip and Mandrel-type Hangers with Bottom Casing Packoff Tested Separately	342
Figure F.7—Pressure/Temperature Cycles for Group 3 Slip and Mandrel-type Hangers with Bottom Casing Packoff Tested Concurrently	342
Figure F.8—Pressure/Temperature Cycles for Group 3 Slip and Mandrel-type Hangers with Bottom Casing Packoff Tested Concurrently	343
Figure H.1—Recommended Bolting Make-up Patterns.....	353
Figure I.1—Flange Bolting Configurations	357
Figure I.2—Studded Bolting Configurations	357
Figure J.1—Weld-neck Flange Dimensions.....	367
Figure J.2—Recommended Weld End Preparation for Type 6B and 6BX Weld-end Flanges	369
Figure K.1—Top Connector for Tree—SI Units	372
Figure K.2—Top Connector for Tree—USC Units.....	376
Figure K.3—Back-up Ring for Seal—SI Units.....	380
Figure K.4—Back-up Ring for Seal—USC Units	382
Figure M.1—Thermocouple Locations—Rectangular Furnace (Working Zone).....	392
Figure M.2—Thermocouple Locations—Cylindrical Furnace (Working Zone)	393

Tables

Table 1—Pressure Ratings for Internal Threaded End or Outlet Connectors	23
Table 2—Temperature Ratings	23
Table 3—Material Requirements.....	24
Table 4—Applicability of Product Specification Levels	26
Table 5—Minimum PSL.....	26
Table 6—Tolerances, Unless Otherwise Stated	28
Table 7—Standard and Nonstandard Material Applications for Bodies, Bonnets, and End and Outlet Connectors	30
Table 8—Standard Material Property Requirements for Bodies, Bonnets,.....	31
Table 9—Charpy V-notch Impact Requirements—10 mm x 10 mm	32
Table 10—Adjustment Factors for Subsize Impact Specimens (PSL 1 to PSL 3)	32
Table 11—Steel Composition Limits for Bodies, Bonnets, and End and Outlet Connector Materials	34
Table 12—Phosphorus and Sulfur Concentration Limits	35
Table 13—Maximum Tolerance Range Limits for Alloying Elements (PSL 3 and PSL 4).....	35
Table 14—Chemical Composition of the Nickel-based Alloy UNS N06625.....	48
Table 15—Minimum Requirements for Closure Bolting.....	50
Table 16—Acceptable Closure Bolting for 6B and 6BX Flanged and Studded Connections	51
Table 17—Allowable Closure Bolting by Temperature Class.....	53
Table 18—Threads for Closure Bolting Used on 6B and 6BX Flanged and.....	53
Table 19—Casting Specification Level Cross-reference to PSL	61
Table 20—Minimum Hardness Values	62
Table 21—Maximum Length of Elongated Indication.....	68
Table 22—Requirements for Welding Bodies, Bonnets, and End and Outlet Connectors.....	69
Table 23—Maximum Length of RT Discontinuities.....	71
Table 24—Maximum Length of UT Discontinuities.....	71
Table 25—Requirements for Stems.....	73
Table 26—Requirements for Valve Bore Sealing Mechanisms and Choke Trim.....	75
Table 27—Hardness Requirements.....	76

Table 28—Acceptance Criteria for the Ring Gasket Surface Finish	77
Table 29—Physical Property Data for Qualification of Homogeneous Elastomers	78
Table 30—Applicability of Factory Acceptance Testing	86
Table 31—Summary of Factory Acceptance Testing Requirements by Equipment Type and PSL	86
Table 32—Pressure-holding Periods for Hydrostatic Testing	89
Table 33—Hydrostatic Shell Test Pressure	90
Table 34—Drift Diameter for Individual Valves and Trees	96
Table 35—Guide to Marking Requirements	98
Table 36—Rated Working Pressures and Size Ranges of Flanges	101
Table 37—Marking for Blind and Test Flanges	105
Table 38—Marking for Studded and Flanged Outlet Connectors	106
Table 39—Marking for Ring Gaskets	108
Table 40—Marking for Tees and Crosses	110
Table 41—Recommended Bullplug Installation Procedure	111
Table 42—Marking for Top Connectors	116
Table 43—Performance Requirements for Crossover Connectors	119
Table 44—Marking for Crossover Connectors	120
Table 45—Performance Requirements for Other End Connectors	121
Table 46—Marking for Spools	122
Table 47—Operating Cycle Requirements for Valves	126
Table 48—Marking for Valves	130
Table 49—Marking for Actuated Valves (Assemblies of Actuators with Valves Prepared for Actuators)	130
Table 50—Performance Requirements for Slip Hangers	133
Table 51—Performance Requirements for Mandrel Hangers	133
Table 52—Marking for Hangers	138
Table 53—Performance Requirements for Group 1 Tubing-head Adapters	139
Table 54—Performance Requirements for Group 2 Tubing-head Adapters	139
Table 55—Marking for Wellhead Equipment	143
Table 56—Marking for Wellhead Connectors	144
Table 57—Performance Requirements for Chokes	146
Table 58—Marking for Chokes	147
Table 59—Marking for Choke Beans	148
Table 60—Performance Requirements for Actuators	149
Table 61—Marking for Actuators	151
Table 62—Summary of Validation Requirements for Safety Valves	153
Table 63—Marking for Safety Valves	156
Table 64—Marking for Trees	157
Table B.1—Relative Corrosivity of Retained Fluids as Indicated by CO ₂ Partial Pressure	187
Table B.2—Recommended Service Limits for Castings	187
Table C.1—Pressure Rating Conversion between SI and USC for API 6A Equipment	189
Table C.2—Conversions for the Radius at Back Face	189
Table C.3—Rounding Values for Hole Sizes and Tolerances	190
Table D.1—Type 6B Flanges for 13.8 MPa	194
Table D.2—Type 6B Flanges for 20.7 MPa	196
Table D.3—Type 6B Flanges for 34.5 MPa	198
Table D.4—Type 6BX Flanges for 69.0 MPa	200
Table D.5—Type 6BX Flanges for 103.5 MPa	202
Table D.6—Type 6BX Flanges for 138.0 MPa	204
Table D.7—Type 6BX Large-bore Flanges for 13.8 MPa, 20.7 MPa, and 34.5 MPa	206
Table D.8—Type R Ring Grooves	208
Table D.9—Type R Ring Gaskets	210
Table D.10—Type RX Ring Gaskets	212
Table D.11—Type BX Ring Grooves	214
Table D.12—Type BX Ring Gaskets	216
Table D.13—Flanged Crosses and Tees	218
Table D.14—Studded Crosses and Tees	222

Table D.15—Bullplugs	226
Table D.16—VR Plug Dimensions, 13.8 MPa, 20.7 MPa, 34.5 MPa, and 69.0 MPa	228
Table D.17—VR Preparation Dimensions, 13.8 MPa, 20.7 MPa, 34.5 MPa, and 69.0 MPa.....	230
Table D.18—VR Plug Thread Gauging Dimensions, 13.8 MPa, 20.7 MPa, 34.5 MPa, and 69.0 MPa	232
Table D.19—VR Preparation Thread Gauging Dimensions, 13.8 MPa, 20.7 MPa, 34.5 MPa, and 69.0 MPa ..	233
Table D.20—HPVR Plug Dimensions, 103.5 MPa and 138.0 MPa	234
Table D.21—HPVR Preparation Dimensions, 103.5 MPa and 138.0 MPa.....	236
Table D.22—Flanged Full-bore Gate Valves	238
Table D.23—Flanged Plug and Ball Valves.....	240
Table D.24—Flanged Swing and Lift Check Valves	242
Table D.25—Center Spacing of Conduit Bores for Dual Parallel Bore Valves for 13.8 MPa, 20.7 MPa, 34.5 MPa, and 69.0 MPa	244
Table D.26—Center Spacing of Conduit Bores for Triple, Quadruple, and Quintuple Parallel Bore Valves for 13.8 MPa, 20.7 MPa, 34.5 MPa, and 69.0 MPa.....	246
Table D.27—Maximum Hanger Outside Diameter for Wellheads	248
Table D.28—Minimum Vertical Full-opening Wellhead Body Bores and Maximum Casing Sizes	249
Table D.29—Pipe Thread Counterbore and Standoff Dimensions	250
Table D.30—Gauging of Casing and Tubing Threads	252
Table E.1—Type 6B Flanges for 2000 psi	256
Table E.2—Type 6B Flanges for 3000 psi	258
Table E.3—Type 6B Flanges for 5000 psi	260
Table E.4—Type 6BX Flanges for 10,000 psi.....	262
Table E.5—Type 6BX Flanges for 15,000 psi.....	264
Table E.6—Type 6BX Flanges for 20,000 psi.....	266
Table E.7—Type 6BX Large-bore Flanges for 2000 psi, 3000 psi, and 5000 psi.....	268
Table E.8—Type R Ring Grooves	270
Table E.9—Type R Ring Gaskets	272
Table E.10—Type RX Ring Gaskets	274
Table E.11—Type BX Ring Grooves.....	276
Table E.12—Type BX Ring Gaskets	278
Table E.13—Flanged Crosses and Tees	280
Table E.14—Studded Crosses and Tees.....	284
Table E.15—Bullplugs.....	288
Table E.16—VR Plug Dimensions, 2000 psi, 3000 psi, 5000 psi, and 10,000 psi.....	290
Table E.17—VR Preparation Dimensions, 2000 psi, 3000 psi, 5000 psi, and 10,000 psi.....	292
Table E.18—VR Plug Thread Gauging Dimensions, 2000 psi, 3000 psi, 5000 psi, and 10,000 psi	294
Table E.19—VR Preparation Thread Gauging Dimensions, 2000 psi, 3000 psi, 5000 psi, and 10,000 psi.....	295
Table E.20—HPVR Plug Dimensions, 15,000 psi and 20,000 psi.....	296
Table E.21—HPVR Preparation Dimensions, 15,000 psi and 20,000 psi	298
Table E.22—Flanged Full-bore Gate Valves	300
Table E.23—Flanged Plug Valves and Ball Valves	302
Table E.24—Flanged Swing and Lift Check Valves	304
Table E.25—Center Spacing of Conduit Bores for Dual Parallel Bore Valves for 2000 psi, 3000 psi, 5000 psi, and 10,000 psi	306
Table E.26—Center Spacing of Conduit Bores for Triple, Quadruple, and Quintuple Parallel Bore Valves for 2000 psi, 3000 psi, 5000 psi, and 10,000 psi	308
Table E.27—Maximum Hanger Outside Diameter for Wellheads	310
Table E.28—Minimum Vertical Full-opening Wellhead Body Bores and Maximum Casing Sizes.....	311
Table E.29—Pipe Thread Counterbore and Standoff Dimensions	312
Table E.30—Gauging of Casing and Tubing Threads	314
Table F.1—Ambient Temperature Gas Leakage Acceptance Criteria.....	318
Table F.2—Standard Test Fluids for Nonmetallic Seals.....	323
Table F.3—Nominal End Connector Sizes	326
Table F.4—Nominal Pipe Sizes	326
Table F.5—Scaling for Nonmetallic Seals.....	327
Table F.6—Summary of Design Validation Requirements for Valves.....	330

Table F.7—Summary of Design Validation Requirements for Actuators	333
Table F.8—Summary of Design Validation Requirements for Chokes	334
Table F.9—Summary of Design Validation Requirements for Casing-head Housings, Casing-head.....	336
Table F.10—Summary of Design Validation Requirements for Group 2 Slip-type Hangers	337
Table F.11—Summary of Design Validation Requirements for Group 3 Slip-type Hangers	338
Table F.12—Summary of Design Validation Requirements for Group 4 Slip-type Hangers	339
Table F.13—Summary of Design Validation Requirements for Group 1 Mandrel-type Hangers	340
Table F.14—Summary of Design Validation Requirements for Group 2 Mandrel-type Hangers	340
Table F.15—Summary of Design Validation Requirements for Group 3 Mandrel-type Hangers	341
Table F.16—Summary of Design Validation Requirements for Group 4 Mandrel-type Hangers	343
Table F.17—Summary of Design Validation Requirements for Group 5 Mandrel-type Hangers	344
Table F.18—Summary of Design Validation Requirements for Packing Mechanisms	345
Table F.19—Summary of Design Validation Requirements for Group 2 Tubing-head Adapters.....	345
Table F.20—Summary of Design Validation Requirements for Other End Connectors	346
Table G.1—Temperature Ratings.....	348
Table G.2—Optional Pressure-temperature Ratings for 6B Flanges	348
Table G.3—Optional Material De-rating Factors for Elevated Temperature.....	351
Table G.4—Optional Material De-rating Factors for Elevated Temperature.....	351
Table H.1—Recommended Torques for Flange Bolting (SI Units).....	354
Table H.2—Recommended Torques for Flange Bolting (USC Units).....	355
Table I.1—Stud Bolt Length Table for 6B Flange Connectors with “R” and “RX” Gaskets	359
Table I.2—Stud Bolt Length Table for 6BX Flange Connectors	360
Table I.3—Tap End Stud Length Table for 6B Studded Flange Connectors with “R” and “RX” Gaskets.....	362
Table I.4—Tap End Stud Length Table for 6BX Studded Flange Connectors	363
Table I.5—Stud Bolt Length Table for 6B Flange Connectors with “R” Gaskets (USC Units).....	364
Table I.6—Tap End Stud Length Table for 6B Studded Flange Connectors with “R” Gaskets	365
Table K.1—Standard Top Connector Sizes	371
Table K.2—Top Connector Body, Inside and Outside Diameter Combinations	371
Table K.3—Dimensions for Top Connectors—SI Units.....	373
Table K.4—Dimensions for Top Connectors—USC Units	377
Table K.5—Seals for Top Connector Plugs for H ₂ S Service	381
Table K.6—Back-up Ring for Seal—SI Units	381
Table K.7—Back-up Ring for Seal—USC Units	382
Table L.1—Dimensions for 34.5 MPa Rated Working Pressure, Segmented Flanges for Dual Completion.....	384
Table L.2—Dimensions for Type RX Ring Grooves and Ring Gasket Used on Segmented Flanges for Dual Completion.....	388

Introduction

The International System of Units (SI) is used in this specification. However, nominal sizes are shown as fractions in the inch system.

The fractions and their decimal equivalents are equal and interchangeable. Metric conversions and inch dimensions in this specification are based on the original fractional inch designs. Functional dimensions have been converted into the metric system to ensure interchangeability of products manufactured in metric or inch systems; see also Annex C.

An “—” symbol when used in tables means that the applicable size, value, or dimension does not apply.

It is necessary that users of this specification be aware that further or differing requirements can be needed for individual applications. This specification is not intended to inhibit a vendor from offering, or the purchaser from accepting, alternative equipment or engineering solutions for the individual application. This can be particularly applicable where there is innovative or developing technology. Where an alternative is offered, it is the responsibility of the vendor to identify any variations from this specification and provide details.

Specification for Wellhead and Tree Equipment

1 Scope

This specification identifies requirements and gives recommendations for the performance, dimensional and functional interchangeability, design, materials, testing, inspection, welding, marking, handling, storing, shipment, and purchasing of wellhead and tree equipment for use in the petroleum and natural gas industries.

This specification does not apply to field use or field testing. This specification also does not apply to repair of wellhead and tree equipment except for weld repair in conjunction with manufacturing. Tools used for installation and service (e.g. running tools, test tools, wash tools, wear bushings, and lubricators) are outside the scope of this standard.

This specification is applicable to the equipment identified in 4.1 and Section 14.

This specification establishes requirements for four product specification levels (PSLs): PSL 1, PSL 2, PSL 3, and PSL 4. A supplemental designation of PSL 3G applies to PSL 3 products that have satisfied the additional requirements of gas testing. The PSL designations define different levels of technical quality requirements.

If product is supplied bearing the API Monogram and manufactured at a facility licensed by API, the requirements of Annex A apply.

Subject matter of Annexes B, C, D, E, F, G, H, I, J, K, L, and M has been arranged in a way that minimizes the impact of changes on users of this document.

2 Normative References

The following referenced documents are indispensable for the application of this document. For dated references, only the edition cited applies. For undated references, the latest edition of the referenced document (including any amendments) applies, except that new editions may be used on issue and shall become mandatory upon the effective date specified by the publisher or 12 months from the date of the revision (where no effective date is specified).

API Recommended Practice 5A3, *Recommended Practice on Thread Compounds for Casing, Tubing, Line Pipe, and Drill Stem Elements*

API Specification 5B, *Threading, Gauging, and Inspection of Casing, Tubing, and Line Pipe Threads*

API Specification 5CT, *Casing and Tubing*

API Standard 6ACRA, *Age-hardened Nickel-based Alloys for Oil and Gas Drilling and Production Equipment*

API Standard 6AV1, *Validation of Safety and Shutdown Valves for Sandy Service*

API Standard 6X, *Design Calculations for Pressure-containing Equipment*

API Recommended Practice 14F, *Design, Installation, and Maintenance of Electrical Systems for Fixed and Floating Offshore Petroleum Facilities for Unclassified and Class 1, Division 1 and Division 2 Locations*

API Specification 16A, *Specification for Drill-through Equipment*

API Specification 17D, *Design and Operation of Subsea Production Systems—Subsea Wellhead and Tree Equipment*

API Specification 20A, *Carbon Steel, Alloy Steel, Stainless Steel, and Nickel Base Alloy Castings for Use in the Petroleum and Natural Gas Industry*

API Specification 20E, *Alloy and Carbon Steel Bolting for Use in the Petroleum and Natural Gas Industries*

API Specification 20F, *Corrosion-resistant Bolting for Use in the Petroleum and Natural Gas Industries*

ASME B1.1¹, *Unified Inch Screw Threads (UN and UNR Thread Form)*

ASME B1.2, *Gages and Gaging for Unified Inch Screw Threads*

ASME B1.3, *Screw Thread Gaging Systems for Acceptability: Inch and Metric Screw Threads (UN, UNR, UNJ, M, and MJ)*

ASME B1.5, *Acme Screw Threads*

ASME B1.8, *Stub Acme Screw Threads*

ASME B1.20.1, *Pipe Threads, General Purpose (Inch)*

ASME Boiler and Pressure Vessel Code, Section V, *Nondestructive Examination*

ASME Boiler and Pressure Vessel Code, Section VIII, Division 1, *Rules for Construction of Pressure Vessels*

ASME Boiler and Pressure Vessel Code:2004 with 2005 and 2006 addenda, Section VIII, Division 2, *Alternative Rules*

ASME Boiler and Pressure Vessel Code, Section IX, *Qualification Standard for Welding, Brazing, and Fusing Procedures; Welders; Brazers; and Welding, Brazing, and Fusing Operators*

ASNT SNT-TC-1A², *Personnel Qualification and Certification in Nondestructive Testing*

ASTM A193/A193M³, *Standard Specification for Alloy-Steel and Stainless Steel Bolting Materials for High Temperature or High Pressure Service and Other Special Purpose Applications*

ASTM A194/A194M, *Standard Specification for Carbon Steel, Alloy Steel, and Stainless Steel Nuts for Bolts for High Pressure or High Temperature Service, or Both*

ASTM A320/A320M, *Standard Specification for Alloy-Steel and Stainless Steel Bolting Materials for Low-Temperature Service*

ASTM A370, *Standard Test Methods and Definitions for Mechanical Testing of Steel Products*

ASTM A388/A388M, *Standard Practice for Ultrasonic Examination of Steel Forgings*

ASTM A453/A453M, *Standard Specification for High-Temperature Bolting Materials, with Expansion Coefficients Comparable to Austenitic Stainless Steels*

¹ American Society of Mechanical Engineers, Two Park Avenue, New York, New York 10016, www.asme.org.

² American Society for Nondestructive Testing, 1711 Arlingate Lane, Columbus, Ohio 43228, www.asnt.org.

³ ASTM International, 100 Barr Harbor Drive, West Conshohocken, Pennsylvania, 19428, www.astm.org.

ASTM A609/A609M, *Standard Practice for Castings, Carbon, Low-Alloy, and Martensitic Stainless Steel, Ultrasonic Examination Thereof*

ASTM D395, *Standard Test Methods for Rubber Property—Compression Set*

ASTM D412, *Standard Test Methods for Vulcanized Rubber and Thermoplastic Elastomers—Tension*

ASTM D471, *Standard Test Method for Rubber Property—Effect of Liquids*

ASTM D1414, *Standard Test Methods for Rubber O-Rings*

ASTM D1415, *Standard Test Method for Rubber Property—International Hardness*

ASTM D1418, *Standard Practice for Rubber and Rubber Latices—Nomenclature*

ASTM D2240, *Standard Test Method for Rubber Property—Durometer Hardness*

ASTM E10, *Standard Test Method for Brinell Hardness of Metallic Materials*

ASTM E18, *Standard Test Methods for Rockwell Hardness of Metallic Materials*

ASTM E110, *Standard Test Method for Rockwell and Brinell Hardness of Metallic Materials by Portable Hardness Testers*

ASTM E92, *Standard Test Methods for Vickers Hardness and Knoop Hardness of Metallic Materials*

ASTM E140, *Standard Hardness Conversion Tables for Metals Relationship Among Brinell Hardness, Vickers Hardness, Rockwell Hardness, Superficial Hardness, Knoop Hardness, Scleroscope Hardness, and Leeb Hardness*

ASTM E165/E165M, *Standard Practice for Liquid Penetrant Examination for General Industry*

ASTM E186, *Standard Reference Radiographs for Heavy-Walled (2 to 4¹/₂ in. (50.8 to 114 mm)) Steel Castings*

ASTM E280, *Standard Reference Radiographs for Heavy-Walled (4¹/₂ to 12 in. (114 to 305 mm)) Steel Castings*

ASTM E428, *Standard Practice for Fabrication and Control of Metal, Other than Aluminum, Reference Blocks Used in Ultrasonic Testing*

ASTM E446, *Standard Reference Radiographs for Steel Castings up to 2 in. (50.8 mm) in Thickness*

ASTM E709, *Standard Guide for Magnetic Particle Testing*

ISO 148-1⁴, *Metallic materials—Charpy pendulum impact test—Part 1: Test method*

ISO 3834 (all parts), *Quality requirements for fusion welding of metallic materials*

ISO 5208, *Industrial valves—Pressure testing of metallic valves*

ISO 6506 (all parts), *Metallic materials—Brinell hardness test*

⁴ International Organization for Standardization, Chemin de Blandonnet 8, CP 401, 1214 Vernier, Geneva, Switzerland, www.iso.org.

ISO 6507 (all parts), *Metallic materials—Vickers hardness test*

ISO 6508 (all parts), *Metallic materials—Rockwell hardness test*

ISO 6892-1, *Metallic materials—Tensile testing—Part 1: Method of test at room temperature*

ISO 9606 (all parts), *Qualification testing of welders—Fusion welding*

ISO 9712, *Non-destructive testing—Qualification and certification of NDT personnel*

ISO 14732, *Welding personnel—Qualification testing of welding operators and weld setters for mechanized and automatic welding of metallic materials*

ISO 15609 (all parts), *Specification and qualification of welding procedures for metallic materials—Welding procedure specification*

ISO 15614-1, *Specification and qualification of welding procedures for metallic materials—Welding procedure test—Part 1: Arc and gas welding of steels and arc welding of nickel and nickel alloys*

ISO 15614-7, *Specification and qualification of welding procedures for metallic materials—Welding procedure test—Part 7: Overlay welding*

ISO 18265, *Metallic materials—Conversion of hardness values*

ISO 2859-1:1999, *Sampling procedures for inspection by attributes—Part 1: Sampling schemes indexed by acceptance quality limit (AQL) for lot-by-lot inspection*

NACE MR0175/ISO 15156⁵, *Petroleum and natural gas industries—Materials for use in H₂S-containing environments in oil and gas production*

SAE AMS-H-6875⁶, *Heat Treatment of Steel Raw Materials*

SAE AS568A, *Aerospace Size Standard for O-Rings*

SAE AMS2750, *Pyrometry*

3 Terms, Definitions, Abbreviated Terms, and Symbols

3.1 Terms and Definitions

For the purposes of this document, the following terms and definitions apply.

3.1.1

accessible wetted surface

Wetted surface for purposes of nondestructive examination (NDE) that can be viewed by direct line of sight.

NOTE This excludes test ports, control line ports, lockdown screw holes, and other penetrations of these types.

3.1.2

actuator

Mechanism for the remote or automatic operation of a valve or choke.

⁵ NACE International, 15835 Park Ten Place, Houston, Texas 77084, www.nace.org.

⁶ SAE International, 400 Commonwealth Drive, Warrendale, Pennsylvania 15096, www.sae.org.

3.1.3**annular packoff**

Mechanism that seals off annular pressure between the outside diameter of a suspended tubular member or hanger and the inside diameter of the head or spool through which the tubular member passes or hanger is suspended.

3.1.4**back-pressure valve**

Unidirectional or bidirectional check valve that is installed through the tree, into the tubing hanger, and prevents well fluids from flowing out of the well.

3.1.5**ball valve**

Valve with a spherical closure member that rotates on an axis perpendicular to the direction of flow.

3.1.6**blind flange**

Flange with no through-bore, which may or may not include a test and gauge connector port, used to close off a flanged or studded end or outlet connector.

NOTE A blind flange with a test and gauge connector port is sometimes called a test flange.

3.1.7**boarding shutdown valve****BSDV**

Automatic valve assembly installed between an underwater production system and a surface facility that closes on loss of power supply.

NOTE Where used in this specification, the term is understood to include a BSDV valve and BSDV actuator.

3.1.8**body**

Any portion of wellhead and tree equipment that includes one or more end connectors and is designed to be exposed to and contain well bore pressure and fluid.

3.1.9**bonnet**

Pressure-containing closure for a body, other than an end or outlet connector.

3.1.10**bottom casing packoff**

Mechanism that seals off annular pressure between the outside diameter of a suspended tubular member or hanger and the inside diameter of the spool or tubing-head adapter placed over the suspended tubular or hanger.

3.1.11**bullplug**

Pressure-containing closure for a female-threaded end or outlet connector that may have an internal counterbore and/or test and gauge connector port.

3.1.12**casing-head housing**

Equipment attached to the uppermost end of the surface casing that serves to suspend and seal a casing string.

3.1.13**casing-head spool**

Equipment attached to another casing head that serves to suspend and seal a secondary casing string.

3.1.14**casting (noun)**

Object at or near finished shape obtained by solidification of a fluid substance in a mold.

NOTE Parts made by hot isostatic pressing are not considered to be a casting.

3.1.15**certificate of conformance**

Document containing the statement by the manufacturer certifying that the equipment meets the requirements of this specification.

3.1.16**check valve**

Valve that permits fluid to flow in one direction and includes a mechanism to automatically prevent flow in the opposite direction.

3.1.17**choke**

Equipment used to restrict and control the flow rate and pressure of fluids.

3.1.18**choke bean****flow bean**

Replaceable orifice part used in positive chokes to control flow rate.

3.1.19**choke trim**

Pressure-controlling choke part, including choke beans, used to control or regulate the flow of fluids.

3.1.20**clamp hub**

Protruding rim with an external angled shoulder and a sealing mechanism used to join pressure-containing equipment.

3.1.21**closure bolting**

Threaded fastener used to assemble well bore pressure-containing parts or join end or outlet connectors.

EXAMPLE Studs, nuts, bolts, and capscrews.

3.1.22**corrosion-resistant alloy****CRA**

Nonferrous-based alloy in which any one or the sum of the specified amount of the elements titanium, nickel, cobalt, chromium, and molybdenum exceeds 50 % mass fraction.

NOTE This definition is different from that in NACE MR0175/ISO 15156.

3.1.23**corrosion-resistant ring groove**

Ring groove lined with a CRA to resist metal-loss corrosion.

3.1.24**critical dimensions**

Toleranced dimensions of features determined by the manufacturer to be essential to the function of the equipment.

3.1.25**cross**

Pressure-containing part with a minimum of four end connectors.

3.1.26**crossover connector**

Product with a restricted-area sealing means and with a top connector pressure rating above that of the lower connector.

NOTE Types of crossover connectors may include crossover spools, multistage crossover spools, crossover adapters, and crossover tubing-head adapters.

3.1.27**date of manufacture**

Date of manufacturer's final acceptance of finished equipment.

3.1.28**end connector****outlet connector**

Any integral feature of a body used as a means to join together equipment that contains pressure, permits flow of retained fluid between the joined equipment, and provides a seal at the joint.

NOTE 1 End and outlet connectors include, but are not limited to, internal or external thread, clamp hub, studded outlet, and studded or through-bolted flange.

NOTE 2 A bonnet connector or a weld preparation is not an end connector.

3.1.29**equipment**

Any product included in the scope of this specification.

3.1.30**equivalent round****ER**

Standard for comparing various shaped sections to round bars, in determining the response to hardening characteristics when heat-treating low-alloy and martensitic corrosion-resistant steel.

3.1.31**exposed bolting**

Bolting that can be exposed directly to a sour environment or that is buried, insulated, equipped with flange protectors, or otherwise denied direct atmospheric exposure.

3.1.32**fitting**

Type of pressure boundary penetration that is used for the purpose of lubrication, maintenance, venting, monitoring, or testing another part.

NOTE A fitting is not an end connector.

3.1.33**flange**

Protruding rim with holes to accept bolts and having a sealing mechanism used to join pressure-containing equipment, with dimensions specified in this specification.

3.1.34**forging (noun)**

Shaped metal part formed by the forging method.

3.1.35**full overlay**

Referring to a welding procedure, welding operations, or equipment where all retained fluid-wetted surfaces are weld overlaid or weld clad with a corrosion-resistant alloy.

3.1.36**full-bore valve**

Valve whose closure mechanism has a bore dimension the same as or larger than the valve body.

3.1.37**fusion face**

Surface of the base metal that will be melted during welding.

3.1.38**gate valve**

Valve assembly with a closure mechanism operating within the body, 90° to the conduit, to affect a closure.

3.1.39**hanger mandrel**

Portion of a casing or tubing hanger that is attached by a threaded connector to the tubular string and forms the upper end of that tubular string.

3.1.40**hanger (mandrel-type)**

Mechanism used to support a casing or tubing string in a casing or tubing head by means of a male or female thread attached to the casing.

3.1.41**hanger (slip-type)**

Mechanism used to support a casing string in a casing head by gripping the pipe with wedge-type members.

3.1.42**heat****heat lot**

Material originating from a final melt, or for remelted alloys, the raw material originating from a single remelted ingot.

3.1.43**heat-treat lot, batch furnace**

Material placed on loading or carrying devices and moved through a heat-treat cycle in the same furnace, including the same quenching practice.

3.1.44**heat-treat lot, continuous furnace**

Group of pieces of material with the same nominal size that is moved sequentially through the heat-treatment process using the same process parameters.

3.1.45**heat-treatment****heat-treat**

Specified, timed sequence of controlled heating and cooling of materials for the purpose of changing physical or mechanical properties.

3.1.46**heat-affected zone****HAZ**

Portion of the base metal that has not been melted, but whose mechanical properties or microstructure has been altered by the heat of welding or cutting.

3.1.47**heat-sensitive lock-open device**

Device installed on a surface safety valve (SSV) actuator to maintain the SSV valve in a full-open position until exposed to sufficient heat to cause the device to release and allow the SSV valve to close.

3.1.48**hot isostatic pressing**

Special forming process used to compact and metallurgically bond metal powder.

NOTE This process takes place within a flexible, metal container whose contents are formed into the desired shape by subjecting the container to high temperature and pressure in an autoclave. It produces a fully wrought structure.

3.1.49**hydrostatic test**

Any pressure test performed with a liquid-state test fluid.

3.1.50**instrument flange**

Spacer flange with a through-bore and one or more test and gauge connector ports from the outside diameter to the through-bore.

3.1.51**job-lot traceability**

Ability to trace parts as originating from a job lot that identifies the included heat(s).

3.1.52**linear indication**

Surface NDE indication whose length is equal to or greater than three times its width.

3.1.53**lock screw****tie-down screw**

Threaded pin extending through the wall of a casing-head or tubing-head connector used to lock down hangers or energize seals.

3.1.54**loose connector****loose flange**

Connector, as-manufactured, that is not intended to be made integral with equipment conforming to this specification.

EXAMPLE Types of loose connectors are blind, threaded, weld-neck, flanged, studded, or other end connectors.

3.1.55**manufacturer**

Organization that produces equipment that meets the requirements of this specification.

3.1.56**multistage crossover spool**

Flanged or other connected equipment with more than one restricted-area sealing means to provide suitable capability to suspend and seal around multiple inner strings of casing or tubing at several stages.

3.1.57**objective evidence**

Documented field experience, test data, publications, finite element analysis, or calculations that confirm performance characteristics, as applicable.

3.1.58**other end connector****OEC**

End or outlet connector of a design not fully specified in this or other reference API specification.

3.1.59**part**

Individual piece used in the assembly of single equipment units.

EXAMPLE Body, bonnet, gate, stud, handwheel, etc., are parts of a valve.

NOTE A part may also be a piece not in finished form.

3.1.60**partial overlay**

Referring to a welding procedure, welding operations or equipment where some, but not all, retained fluid-wetted surfaces are weld overlaid or weld clad with a corrosion-resistant alloy.

3.1.61**plug valve**

Valve assembly with a closure mechanism mounted across the conduit so that, when rotated 90°, it effects a closure.

EXAMPLE Plugs may be straight or tapered.

3.1.62**post-weld heat-treatment**

Any heat-treatment subsequent to welding for the purpose of stress relief.

3.1.63**pressure boundary penetration**

Device that penetrates directly into or communicates with the well bore.

3.1.64**pressure-containing part**

Part whose failure to function as intended results in a release of retained fluid to the atmosphere.

EXAMPLE Bodies, bonnets, one-piece stems, and that segment of multipiece stems that passes through the pressure boundary, are pressure-containing parts.

3.1.65**pressure-containing weld**

Closure weld that is part of the pressure envelope of the part and contributes to the retention of pressure.

3.1.66**pressure-controlling part**

Part intended to control or regulate the movement of pressurized fluids.

EXAMPLE Valve bore sealing mechanisms, choke trim, and hangers.

3.1.67**pressure integrity**

Structural and leak-resistant capability of a product to contain applied pressure.

3.1.68**primary equipment**

Pieces of equipment that cannot normally be isolated from well fluid or well pressure.

3.1.69**prolongation**

Extension of a piece of raw material or an extension of a production part made integrally during forging, hot working, cold working, or casting.

3.1.70**proration bean**

Type of positive choke bean of fixed length used to regulate the flow of fluid from a well.

NOTE Proration is a system of allocating the amount of oil or gas a well or field is allowed to produce within a given period by a regulatory agency.

3.1.71**purchaser**

Organization that buys equipment from the manufacturer.

3.1.72**rated working pressure**

Maximum internal pressure that the equipment is specified to contain and/or control when in operation.

3.1.73**reduced-opening valve**

Valve with an opening through the valve bore sealing mechanism, where that opening is smaller in area than the minimum bore as specified in 14.11.

3.1.74**relevant indication**

Surface NDE indication with major dimensions greater than 1.6 mm ($1/16$ in.).

NOTE An indication not associated with a surface rupture is not considered to be a relevant indication.

3.1.75**repair weld**

Welding used to restore a part to design requirements or to improve appearance.

3.1.76**restricted-area sealing means**

Packoff or other device used to isolate an area at higher pressure from one at lower pressure.

NOTE This device serves to limit pressure-induced loads on connectors or areas of a lower-pressure rating. It may also be a seal that encloses a pressure-containment area smaller than the adjacent ring gasket or connector seal.

3.1.77**retained fluid**

Actual fluid produced by a well or injected into a well.

3.1.78**rounded indication**

Surface NDE indication that is circular or elliptical, having a length less than 3 times its width.

3.1.79**safety valve**

Surface safety valve (SSV) or underwater safety valve (USV) or boarding shutdown valve (BSDV), as defined in this specification.

NOTE A safety valve is any one of the valves of 3.1.87 assembled with the corresponding actuator of 3.1.86.

3.1.80**safety valve actuator**

Any one of the actuators of 3.1.86.

3.1.81**sandy service**

Application where the retained fluid could contain particulates such as sand.

3.1.82**secondary equipment**

Piece of equipment that can normally be isolated from the well fluid or well pressure.

3.1.83**serialization**

Assignment of a unique code to an individual part and/or piece of equipment to maintain records.

3.1.84**shell test**

Hydrostatic test required by this specification that exceeds the rated working pressure.

3.1.85**slip bowl**

Piece of equipment between the wedge type members and casing-head bowl.

3.1.86**SSV actuator****USV actuator****BSDV actuator**

Device that causes the SSV/USV/BSDV to open when power is supplied and to close automatically when power is lost or released.

3.1.87**SSV valve****USV valve****BSDV valve**

Portion of the SSV/USV/BSDV that contains the well stream and shuts off flow when closed.

3.1.88**stainless steel**

Steel containing more than 11 % mass fraction chromium to render the steel corrosion-resistant.

NOTE Other elements may be added to secure special properties.

3.1.89**studded connector**

End or outlet connector in which thread-anchored studs screwed into tapped holes replace the holes for bolt studs.

3.1.90**substantive change**

Change identified by the manufacturer that affects the performance of the product in the intended service.

3.1.91**surface safety valve****SSV**

Automatic wellhead valve assembly that closes upon loss of power supply.

NOTE Where used in this specification, the term is understood to include an SSV valve and SSV actuator.

3.1.92**supply pressure rating**

Maximum hydraulic or pneumatic pressure specified to operate an actuator.

3.1.93**swab valve****crown valve**

Uppermost valve on the vertical bore of the tree above the flowline outlet.

3.1.94**tee**

Pressure-containing part with three end connectors; two openings opposite one another form the run portion of the tee, and one opening is at 90° to the line of the run.

NOTE Tees may be equipped with threads, flanges, studs, or other end connectors.

3.1.95**test agency**

Independent party that provides a test facility and administers a testing program that meets the SSV/USV/BSDV valve-validation testing requirements of API 6AV1.

3.1.96**test and gauge connector port**

Port in wellhead and tree equipment for attachment of a fitting (see 3.1.32).

3.1.97**threaded flange**

Flange having a sealing face on one side and a female thread on the other for joining flanged connectors to threaded connectors.

3.1.98**top connector****tree cap**

Uppermost part of a tree that allows access to the vertical bores of the tree.

3.1.99**tree**

Assembly of equipment, including tubing-head adapters, valves, tees, crosses, top connectors, and chokes attached to the uppermost connector of the tubing head, used to control well production.

NOTE This is sometimes referred to as a "christmas tree."

3.1.100**tubing hanger mandrel**

Mechanism used to support a tubing string in a tubing head by means of a male or female thread attached to the tubing.

3.1.101**tubing-head adapter**

Equipment that adapts the uppermost connector of a tubing head to the lowermost valve of the tree.

3.1.102**tubing-head spool**

Piece of equipment attached to the uppermost casing head or smallest casing string that serves to suspend the tubing and to seal the annular space between the tubing and casing.

3.1.103
underwater safety valve
USV

Automatic valve assembly installed at an underwater wellhead location that closes on loss of power supply.

NOTE Where used in this specification, the term is understood to include a USV valve and USV actuator.

3.1.104
user

User of this specification.

3.1.105
valve bore sealing mechanism

Internal valve parts that close off the flow through the valve bore.

EXAMPLE Gates, balls, plugs, poppets, flappers, and their respective seats.

3.1.106
valve-removal plug

Threaded plug that can be installed in the wellhead to enable gate valve removal under pressure.

3.1.107
visible leakage

Leakage of test fluid seen during a pressure test, either through direct observation or with the use of video equipment.

NOTE Leakage may be observed through or past a pressure boundary or at an interface.

3.1.108
wear bushing

Retrievable cylindrical device that protects the internal surfaces of wellhead equipment and the top of the last casing suspended.

3.1.109
weld-neck flange

Flange with a neck on the side opposite the sealing face terminating in a weld preparation.

3.1.110
well bore

Cavity that contains retained fluid.

3.1.111
wellhead

All permanent equipment between the uppermost portion of the surface casing and the tubing-head adapter connector.

3.1.112
wetted surface

Any surface that has contact with pressurized well fluid, either by design or because of internal seal leakage.

3.1.113
wrought

Product, structure, or material that contains no cast dendritic elements.

3.1.114
yield strength

Stress level at which material plastically deforms and does not return to its original dimensions when the load is released based on the 0.2 % offset method in accordance with ISO 6892-1 or ASTM A370.

3.2 Abbreviated Terms

AQL	acceptance quality limit
BSDV	boarding shutdown valve
BSL	bolting specification level
CRA	corrosion-resistant alloy
CSL	casting specification level
DAC	distance amplitude curve
ER	equivalent round
H ₂ S	hydrogen sulfide
HAZ	heat-affected zone
HBW	Brinell hardness
HRBW	Rockwell hardness scale B
HRC	Rockwell hardness scale C
HPVR	high-pressure valve removal (plug)
HVOF	high-velocity oxygen fuel
MT	magnetic particle test
NA	not applicable
NDE	nondestructive examination
NPT	American national standard taper pipe thread
NS	nonstandard
OD	outside diameter
OEC	other end connector
PMR	per manufacturer's requirement
PQR	procedure qualification record
PR	performance requirement
psi	pounds per square inch (gauge)
psia	pounds per square inch absolute
PSL	product specification level

PT	penetrant test
QTC	qualification test coupon
RMS	root mean square
ROE	radius of exposure
RT	radiographic test
SCC	stress corrosion cracking
SI	International System of Units
SSC	sulfide stress cracking
SSV	surface safety valve
TPI	threads per inch
UNS	unified numbering system
USC	US Customary
USV	underwater safety valve
UT	ultrasonic test
VR	valve removal (plug)
WPQ	welder performance qualification
WPQR	welder performance qualification record
WPS	welding procedure specification

3.3 Symbols

A_s	stress area
E_{ty}	elevated-temperature yield strength
R_m	ultimate tensile strength
R_{ty}	room-temperature yield strength
S_A	allowable tensile stress
S_e	de-rated material yield strength
S_E	maximum allowable equivalent stress at the most highly stressed distance into the pressure vessel wall

S_{my}	minimum specified room-temperature yield strength
S_Y	material-specified minimum yield strength
T	thickness
Y_r	yield reduction ratio at temperature
τ	torque

4 Application and Performance

4.1 Applicability

NOTE The nomenclature used in this specification for typical equipment is shown in Figure 1, Figure 2, and Figure 3.

This specification shall be applicable to the following specific equipment:

- a) plugs, connectors, and gaskets—API defined (applicable product-specific sections referenced as follows):
 - integral, blind, and test flanges (see 14.1);
 - ring gaskets (see 14.2);
 - threaded connectors (see 14.3);
 - tees and crosses (see 14.4);
 - bullplugs (see 14.5);
 - valve-removal plugs (see 14.6);
 - top connectors (standard) (see 14.7);
- b) plugs and connectors—manufacturer-defined (applicable product-specific sections referenced as follows):
 - top connectors (nonstandard) (see 14.7);
 - crossover connectors (single- or double-studded, single- or multistage) (see 14.8);
 - other end connectors (OECs) (see 14.9);
 - spools (adapter and spacer) (see 14.10);
- c) valves (all types except back-pressure valves) (see 14.11):
 - gate, plug, and ball valves;
 - single and multiple valves;
 - actuated valves (manual and remote);
 - valves prepared for actuators;

- check valves (swing- and lift-type);
- back-pressure valves (see 14.12);
- d) casing and tubing hangers (see 14.13):
 - slip-type;
 - mandrel-type;
- e) casing and tubing heads (housings and adapters) (see 14.14);
- f) chokes (fixed, manually actuated, remotely actuated) (see 14.15);
- g) actuators (for valves and chokes) (see 14.16);
- h) safety valves, shutdown valves, and actuators (see 14.17):
 - surface safety valve (SSV) assemblies, valves prepared for actuators, and actuators;
 - underwater safety valve (USV) assemblies, valves prepared for actuators, and actuators;
 - boarding shutdown valve (BSDV) assemblies, valves prepared for actuators, and actuators;
- i) tree assemblies (see 14.18);
- j) other:
 - packing mechanisms for lock screws, alignment pins, and retainer screws (see Section 9);
 - fittings and pressure boundary penetrations (see Section 9);
 - test, gauge, vent, and injection connector ports (see Section 9);
 - weld-neck flanges (see Annex J).

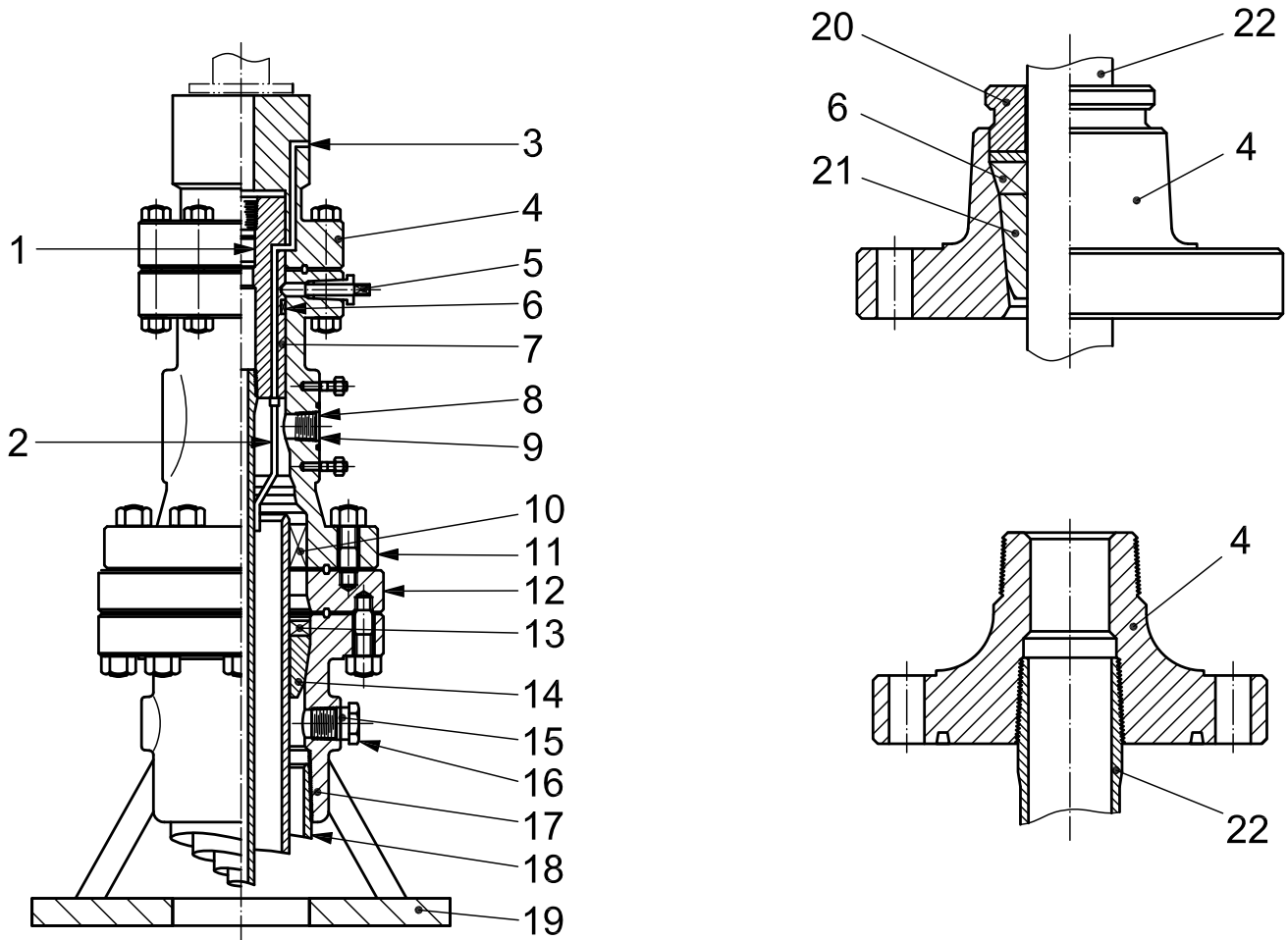

Key

- | | |
|---|---|
| 1 back-pressure valve preparation | 12 adapter spool (double-studded) |
| 2 subsurface safety valve control line | 13 annular casing packoff |
| 3 subsurface safety valve control line outlet | 14 casing hanger (slip style) |
| 4 tubing-head adapter | 15 threaded outlet connection |
| 5 lock screw | 16 bullplug |
| 6 tubing hanger packoff | 17 casing-head housing |
| 7 extended neck tubing hanger with subsurface safety valve control line | 18 surface casing |
| 8 studded side outlet | 19 wellhead support plate or landing base |
| 9 valve-removal preparation | 20 tubing packoff retainer |
| 10 bottom casing packoff | 21 tubing hanger (slip style) |
| 11 tubing-head spool | 22 tubing |

Figure 1—Typical Wellhead Assembly Nomenclature

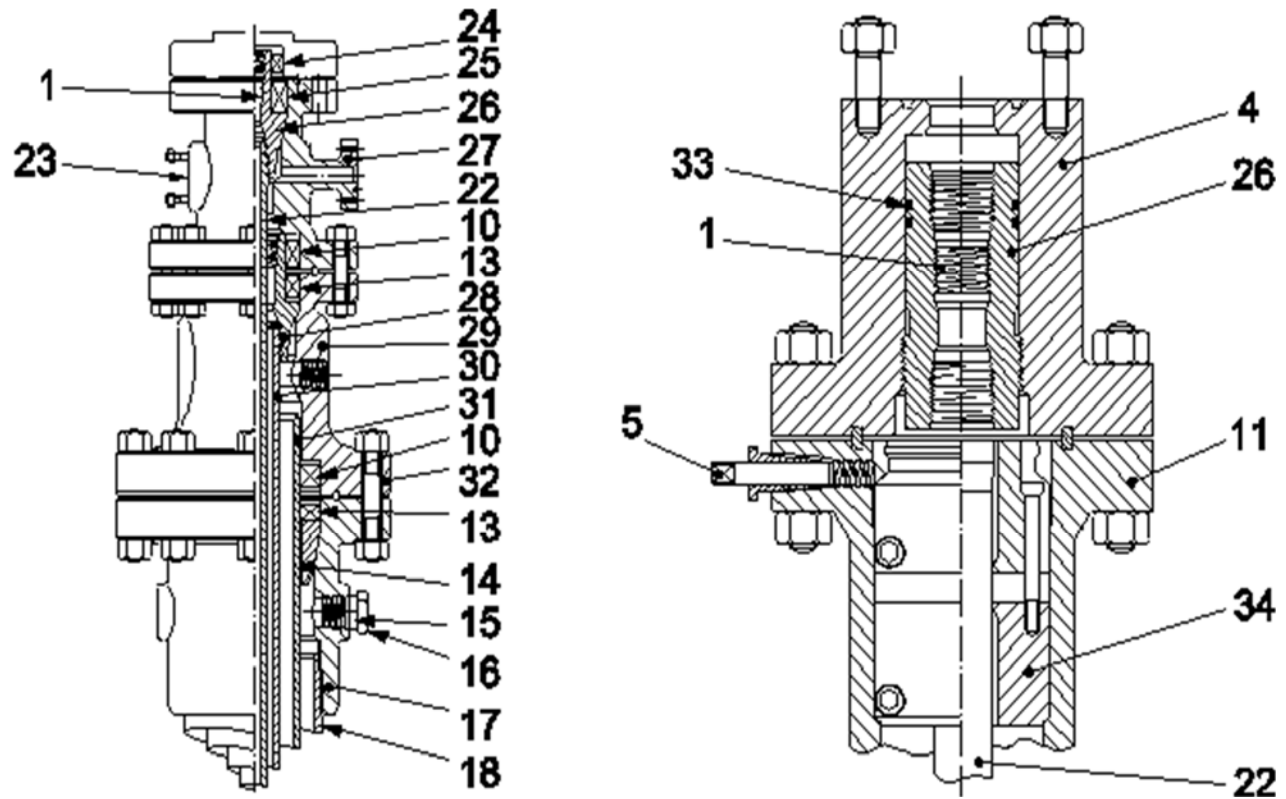

Key

- | | | | |
|----|---------------------------------|----|----------------------------------|
| 1 | back-pressure valve preparation | 23 | studded side-outlet connector |
| 4 | tubing-head adapter | 24 | extended neck tubing hanger seal |
| 5 | lock screw | 25 | annular tubing hanger seal |
| 10 | bottom casing packoff | 26 | tubing hanger mandrel |
| 11 | tubing-head spool | 27 | flanged outlet connector |
| 13 | annular casing packoff | 28 | casing hanger mandrel |
| 14 | casing hanger (slip style) | 29 | casing-head spool |
| 15 | threaded outlet connection | 30 | inner casing |
| 16 | bullplug | 31 | intermediate casing |
| 17 | casing-head housing | 32 | flanged end connector |
| 18 | surface casing | 33 | tubing hanger mandrel seals |
| 22 | tubing | 34 | wrap-around hanger packoff |

Figure 2—Typical Wellhead Assembly Nomenclature

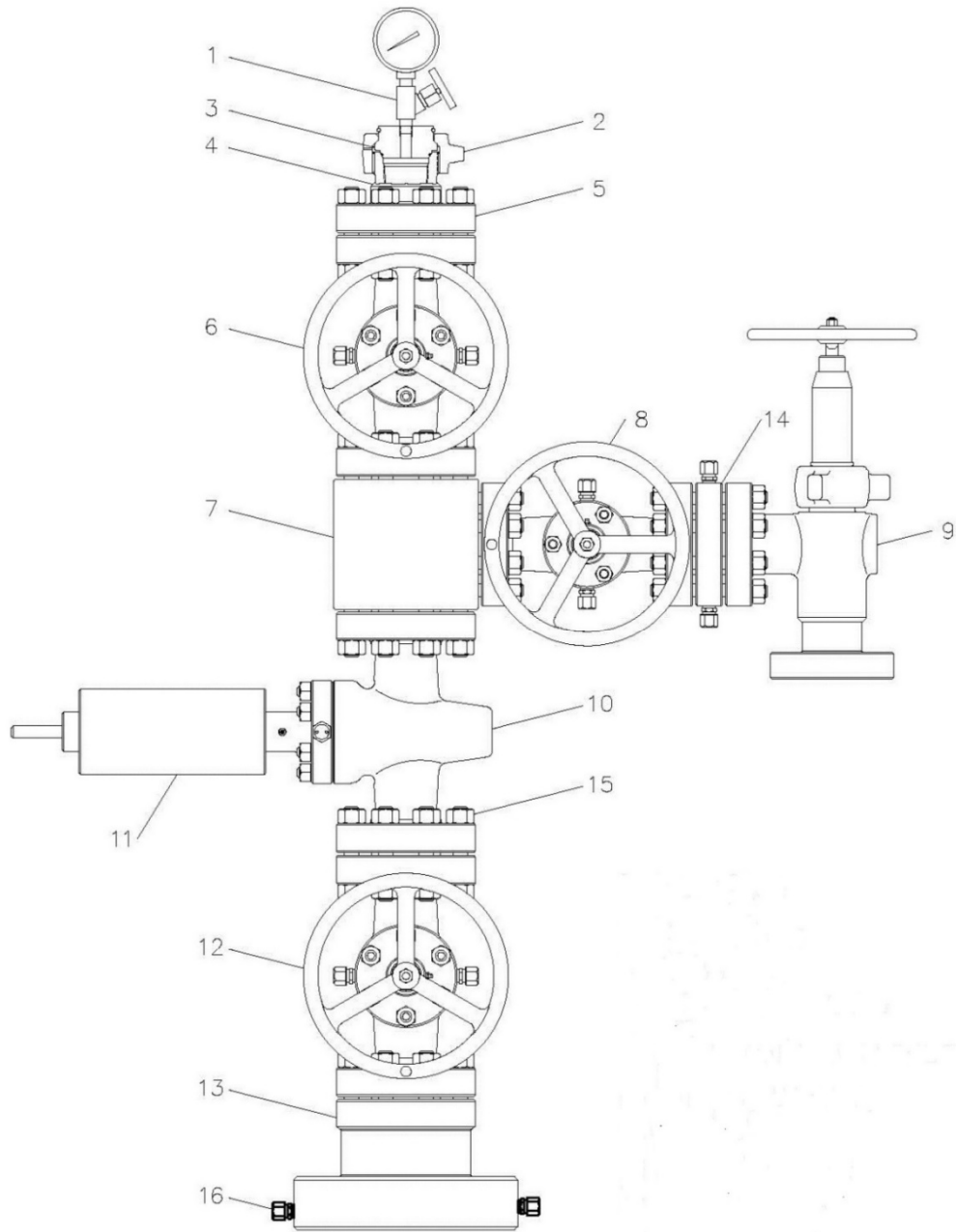

Key

- | | | |
|-----------------------|-----------------------------------|--|
| 1 gauge valve | 7 tee | 13 tubing-head adapter |
| 2 bonnet nut | 8 wing valve (manual or actuated) | 14 instrument flange |
| 3 blanking plug | 9 choke | 15 closure bolting |
| 4 body | 10 surface safety valve | 16 test port-pressure boundary penetration |
| 5 top connector | 11 SSV actuator | |
| 6 swab or crown valve | 12 master valve | |

Figure 3—Typical Tree Nomenclature

4.2 Performance Requirements—General

All equipment shall be designed to perform according to the requirements of Section 4 and Section 5 and the relevant requirements specified in Section 14 while in the pressure and temperature ranges and used with the test fluids consistent with the material class (see 4.3.3) for which they are rated.

NOTE 1 There are two performance requirements (PR1 and PR2) that are specific and unique to the product in the as-shipped condition.

NOTE 2 See Annex B for other requirements that may be specified by the purchaser.

PR1 or PR2 shall apply to products when specified in Section 14. Equipment identified as PR2F shall have design validation completed in accordance with Annex F of this specification, including criteria for scaling.

NOTE 3 PR2F is a designation identifying one specific validation to PR2. Other methods of validating products to PR2 are possible.

4.3 Service Conditions

4.3.1 Pressure Ratings

4.3.1.1 General

Equipment, except actuators, shall be designed to operate at only the following rated working pressures:

- 13.8 MPa (2000 psi);
- 20.7 MPa (3000 psi);
- 34.5 MPa (5000 psi);
- 69.0 MPa (10,000 psi);
- 103.5 MPa (15,000 psi);
- 138.0 MPa (20,000 psi).

4.3.1.2 Threaded Equipment Limitations

Equipment designed with internally threaded end and outlet connectors shall be limited to the thread sizes and rated working pressures in Table 1. Table 1 shall not apply to tubing and casing hangers.

4.3.1.3 Design Inputs

Designs shall account for the effects of pressure containment and other pressure-induced loads, including (but not limited to) pressure rating changes in crossover connectors, pressurizing with temporary test plugs, or other applicable special conditions.

NOTE The capacity for external loading (e.g. bending moments, tensions, etc.) on the rating of equipment is not explicitly addressed by this specification (see B.2).

Table 1—Pressure Ratings for Internal Threaded End or Outlet Connectors

Type of Thread	Nominal Sizes of Pipe, Tubing, or Casing in.	Rated Working Pressure	
		MPa	psi
NPT	1/2	69.0	10,000
	3/4 to 1 1/2	34.5	5000
Line pipe	1/2	69.0	10,000
	3/4 to 2	34.5	5000
	2 1/2 to 6	20.7	3000
Tubing, nonupset, and external upset round thread	1.050 to 4 1/2	34.5	5000
Casing (8 round, buttress, and extreme line)	4 1/2 to 10 3/4	34.5	5000
	11 3/4 to 13 3/8	20.7	3000
	16 to 20	13.8	2000

4.3.2 Temperature Ratings

Equipment shall be designed to operate in one or more of the specified temperature classes with minimum and maximum temperatures as shown in Table 2, or to minimum and maximum temperature ratings as agreed between the purchaser and manufacturer.

Table 2—Temperature Ratings

Temperature Class	Temperature Range			
	°C		°F	
	min.	max.	min.	max.
K	-60	82	-75	180
L	-46	82	-50	180
N	-46	60	-50	140
P	-29	82	-20	180
S	-18	60	0	140
T	-18	82	0	180
U	-18	121	0	250
V	2	121	35	250

NOTE Minimum temperature is the lowest ambient temperature to which the equipment can be subjected. Maximum temperature is the highest temperature of the fluid that can directly contact the equipment.

Design for temperature ratings above 121 °C (250 °F), e.g. classifications X and Y (see Table G.1), shall account for the effects of temperature on material strength (see Annex G for guidelines).

4.3.3 Material Classes

4.3.3.1 General

Equipment shall be designed with materials that meet the requirements specified in Table 3.

Table 3—Material Requirements

Material Class		Body, Bonnet, End and Outlet Connectors	Mandrel Hangers, Valve Bore Sealing Mechanisms, Choke Trim, and Stems
AA	General service	Carbon or low-alloy steel, or stainless steel or CRA ^d	Carbon or low-alloy steel, or stainless steel or CRA ^d
BB	General service	Carbon or low-alloy steel, or stainless steel or CRA ^d	Stainless steel or CRA ^d
CC	General service	Stainless steel or CRA ^d	Stainless steel or CRA ^d
DD	Sour service ^a	Carbon or low-alloy steel or CRA ^{b,d}	Carbon or low-alloy steel, or stainless steel or CRA ^{b,d}
EE	Sour service ^a	Carbon or low-alloy steel or CRA ^{b,d}	Stainless steel or CRA ^{b,d}
FF	Sour service ^a	Stainless steel or CRA ^{b,d}	Stainless steel or CRA ^{b,d}
HH	Sour service ^a	CRA ^{b,c,d}	CRA ^{b,c,d}
FOOTNOTES ^a As defined by NACE MR0175/ISO 15156. ^b In accordance with NACE MR0175/ISO 15156 and 4.3.3.2. ^c CRA required on retained fluid-wetted surfaces only; CRA cladding of low-alloy or stainless steel is permitted (see 7.5.1.2). ^d CRA as defined in 3.1.22; NACE MR0175/ISO 15156 definition of CRA does not apply.			

4.3.3.2 Material Classes for Sour Service

For material classes DD, EE, FF, and HH, the manufacturer shall meet the requirements of NACE MR0175/ISO 15156 for material processing and material properties (e.g. hardness).

NOTE 1 Choosing material class and specific materials for specific conditions is ultimately the responsibility of the purchaser.

Material classes DD, EE, FF, and HH shall include as part of the designation and marking the maximum allowable partial pressure of hydrogen sulfide (H₂S), when a value is specified by NACE MR0175/ISO 15156, in units consistent with the rated working pressure markings and prefixes. Where no H₂S limit is defined by NACE MR0175/ISO 15156 for the partial pressure, no partial pressure shall be marked. The maximum allowable partial pressure shall be in accordance with NACE MR0175/ISO 15156 at the designated temperature rating (see Table 2) for the limiting part(s) in the equipment assembly. When the rated working pressure is marked in pounds per square inch, the H₂S partial pressure limit shall be marked in pounds per square inch.

EXAMPLE 1 “FF-10” on equipment with the rated working pressure marked in megapascals indicates material class FF rated at 10 kPa H₂S maximum allowable partial pressure when used within the environmental limits specified in NACE MR0175/ISO 15156.

EXAMPLE 2 “FF” would be marked on a tee with a body constructed from a material that does not have an H₂S limit specified in NACE MR0175/ISO 15156 with a pH ≥ 3.5.

NOTE 2 API 6A requires the manufacturer to mark only the H₂S partial pressure and not the other parameters specified in NACE MR0175/ISO 15156 to define the environmental limits for H₂S service. Resistance to cracking caused by H₂S is influenced by several other factors, some of the limits for which are given in NACE MR0175/ISO 15156. These include, but are not limited to, the following:

- pH;
- temperature;
- chloride concentration;
- elemental sulfur.

NOTE 3 In making the material selections, it is the responsibility of the purchaser to consider the various environmental factors and production variables listed in Annex B.

NOTE 4 Other forms of cracking may result from the presence of chlorides (such as seawater) and or hydrogen (such as cathodic protection).

4.3.3.3 Material Class ZZ

NOTE NACE MR0175/ISO 15156 includes provisions by means of testing or documented field history for the qualification of materials for a specific sour-service application that is outside the parameters defined in NACE MR0175/ISO 15156. This can include the use of materials in fluid conditions exceeding the limits defined in NACE MR0175/ISO 15156, or the use of materials not addressed in NACE MR0175/ISO 15156. For such sour-service applications, equipment may be described and marked as material class ZZ.

It shall be the responsibility of the purchaser to evaluate and determine the applicability of the documented data for the intended application. For material class ZZ, the manufacturer shall meet material specifications supplied or approved by the purchaser and shall maintain traceable records to document the materials of construction, regardless of PSL.

4.3.4 Product Specification Level

4.3.4.1 Application

PSL designations shall define different levels of technical quality requirements as identified in this specification. Products manufactured to the requirements of this specification shall satisfy the material, welding, quality, and testing requirements for a PSL (PSL 1, PSL 2, PSL 3, and PSL 4), when applicable. PSLs shall be applied to products as designated in Table 4.

NOTE PSL does not apply to all products of this specification.

A supplemental designation of PSL 3G shall apply to PSL 3 products that have satisfied the PSL 3 requirements in addition to the requirements of gas testing.

4.3.4.2 Minimum PSL

The minimum PSL required for material class and rated working pressure combinations shall conform to Table 5.

NOTE Annex B provides guidelines (not requirements) for selecting an acceptable PSL.

For crossover connectors, the PSL shall be based on the higher-pressure rating and material class. For mandrel hangers, the PSL should be based on the pressure rating and material class of the spool or tubing-head adapter placed over the suspended hanger.

Table 4—Applicability of Product Specification Levels

Equipment Category and Type (Reference Section)	Applicable PSLs	Equipment Category and Type (Reference Section)	Applicable PSLs
Plugs, Connectors, Gaskets		Valves and Chokes	
Flanges (blind, test) ^a (see 14.1)	1, 2, 3, 4	Valves (gate, plug, ball) (see 14.11)	1, 2, 3 ^e , 4
Ring gaskets ^b (see 10.4.5 and 14.2)	NA	Valves (prepared for/and actuated) (see 14.11)	1, 2, 3 ^e , 4
Threaded connectors ^a (see 14.3)	1, 2, 3, 4	Check valves (see 14.11)	1, 2, 3 ^e , 4
Tees and crosses (see 14.4)	1, 2, 3 ^e , 4	Back-pressure valves ^b (see 14.12)	NA
Bullplugs ^b (see 14.5)	NA	SSVs and USVs ^c (see 14.17)	2, 3 ^e , 4
Valve-removal plugs ^b (see 14.6)	NA	BSDVs ^d (see 14.17)	3 ^e , 4
Top connectors (see 14.7)	1, 2, 3 ^e , 4	Chokes (adjustable and positive) (see 14.15)	1, 2, 3 ^e , 4
Crossover connectors (see 14.8)	1, 2, 3 ^e , 4	Casing and Tubing Heads	
Other end connectors ^a (see 14.9)	1, 2, 3, 4	Housings (see 14.14)	1, 2, 3 ^e , 4
Spools (adapter, spacer) (see 14.10)	1, 2, 3 ^e , 4	Adapters (see 14.14)	1, 2, 3 ^e , 4
Weld-neck flanges ^a (see J.1)	1, 2, 3, 4	Other Equipment	
Segmented flanges ^a (see L.1)	1, 2, 3, 4	Actuators ^b (see 14.16)	NA
Nonintegral metal seals ^a (see 10.4.5)	NA	Tree assemblies ^b (see 14.18)	NA
Casing and Tubing Hangers		Packing mechanisms ^b (see 9.1)	NA
Slip-type ^a (see 14.13)	1, 2, 3, 4	Pressure boundary penetrations ^b (see 9.2)	NA
Mandrel-type ^a (see 14.13)	1, 2, 3, 4	Test and gauge ports ^b (see 9.3)	NA
FOOTNOTES ^a Gas testing is not required, so PSL 3G designation is not applicable. ^b There is only one level of requirements for these products, so PSLs are not applicable (NA). ^c PSL 1 is not applicable to SSVs and USVs. ^d PSL 1 and PSL 2 are not applicable to BSDVs. ^e For products eligible for gas testing, PSL 3G designation and marking may apply.			

Table 5—Minimum PSL

Material Class	Rated Working Pressure					
	13.8 MPa (2000 psi)	20.7 MPa (3000 psi)	34.5 MPa (5000 psi)	69.0 MPa (10,000 psi)	103.5 MPa (15,000 psi)	138.0 MPa (20,000 psi)
AA, BB, CC	PSL 1	PSL 1	PSL 1	PSL 2	PSL 2	PSL 3
DD, EE, FF	PSL 1	PSL 1	PSL 1	PSL 2	PSL 3	PSL 3
HH, ZZ	PSL 3	PSL 3	PSL 3	PSL 3	PSL 3	PSL 4

5 Design

5.1 Design Methods

5.1.1 End and Outlet Connectors

End and outlet connectors shall be an integral part of the body or attached by welding that meets the requirements of Section 7.

NOTE 1 Information on design analysis and load capacities of flanges specified in this specification can be found in API 6AF, API 6AF1, and API 6AF2.

Design of 16B and 16BX end and outlet clamp hub connectors used on equipment specified in this specification shall conform to the material strength and dimensional requirements of API 16A.

NOTE 2 Clamps meeting the requirements of API 16A are acceptable for installation on equipment specified in this specification with clamp hub end connectors meeting the requirements of API 16A.

5.1.2 Hangers, Back-pressure Valves, Lock Screws, and Stems

Casing hangers, tubing hangers, back-pressure valves, lock screws, and stems shall be designed to satisfy the manufacturer's documented performance characteristics and service conditions in accordance with 4.3. The manufacturer shall document engineering practices and acceptance criteria on which the design is based.

5.1.3 Bodies, Bonnets, and Other End Connectors

5.1.3.1 General

OECs, bodies, and bonnets (in designs other than those specified in this specification) shall be designed in accordance with one or more of the methods given in 5.1.3.2, 5.1.3.3, and 5.1.3.4.

If stress levels calculated by the methods in 5.1.3.2, 5.1.3.3, and 5.1.3.4 exceed the allowable stresses, other methods identified by the manufacturer shall be used to justify these stresses.

NOTE Fatigue analysis and localized bearing stress values are outside the scope of this specification.

5.1.3.2 API Standard 6X

If used, design calculations for pressure-containing equipment shall conform to the design methodology of API 6X. The use of von Mises equivalent stress shall be permitted.

5.1.3.3 Distortion Energy Theory

If used, design calculations for pressure-containing equipment shall conform to the von Mises yield criterion (also known as the maximum distortion energy theory of failure). Rules for the use and impact of discontinuities and stress concentrations are outside the scope of this method. However, the basic pressure-vessel wall thickness may be sized by combining triaxial stresses based on hydrostatic shell test pressure and limited by the criterion in Equation 1:

$$S_E = S_Y \quad (1)$$

where

S_E is the maximum allowable equivalent stress at the most highly stressed distance into the pressure vessel wall, computed by the distortion energy theory method;

S_Y is the material-specified minimum yield strength.

5.1.3.4 Experimental Stress Analysis

If experimental stress analysis is used as an alternative to 5.1.3.2 or 5.1.3.3, it shall conform to ASME *BPVC*:2004 with 2005 and 2006 addenda, Section VIII, Division 2, Appendix 6.

5.1.3.5 Tapped Holes for Studded Connections Other Than Flanges

The stud thread-anchoring configuration shall be designed to sustain a tensile load equivalent to the load that can be transferred to the stud through a fully engaged nut.

5.1.4 Other Parts

All other pressure-containing parts and all pressure-controlling parts shall be designed to satisfy the manufacturer's documented performance characteristics and the service conditions in 4.3. The manufacturer shall document engineering practices and acceptance criteria on which the design is based.

5.1.5 Equipment-specific Requirements

NOTE Equipment-specific requirements are specified in Section 14.

5.2 Design Tolerances

Unless otherwise specified in the appropriate table or figure, the tolerances in Table 6 shall apply to dimensions included in this specification.

Table 6—Tolerances, Unless Otherwise Stated

SI		USC	
Dimension	Tolerance mm	Dimension	Tolerance in.
x.x	± 0.5	x.xx	± 0.02
x.xx	± 0.13	x.xxx	± 0.005

5.3 Design Documentation

Documentation of designs shall include methods, assumptions, calculations, and design requirements. Design requirements shall include, but not be limited to, those criteria for size, test and operating pressures, material, environmental, and other pertinent requirements on which the design is based. Design documentation media shall be clear, legible, reproducible, and retrievable. Design documentation shall be retained for 5 years after the last unit of that model, size, and rated working pressure is manufactured.

5.4 Design Review and Verification

Design documentation shall be reviewed and verified by any qualified individual other than the individual who created the original design.

5.5 Design Validation

Manufacturers shall document their design validation procedures and the results of design validation.

Design validation shall be performed in accordance with Annex F when specified by the manufacturer or purchaser.

6 Materials

6.1 General

Bodies, bonnets, end and outlet connectors, clamp hub end connectors, hangers, pressure boundary penetrations, and ring gaskets shall meet the requirements of Section 6. Other pressure-containing and pressure-controlling parts shall be made of materials that satisfy 6.2.1 and the requirements of Section 4 and Section 5.

Material requirements in Section 6 shall apply to carbon steels, low-alloy steels, and martensitic stainless

steels (other than precipitation-hardening types). Other alloy systems (including precipitation-hardening stainless steels) shall satisfy the applicable requirements of Section 4, Section 5, and Section 6.

Age-hardened nickel-based alloys for pressure-containing and pressure-controlling parts that are addressed in API 6ACRA shall conform to API 6ACRA.

Materials for actuators shall be as specified in 14.16.3.

6.2 Written Specifications

6.2.1 Applicability

All metallic and nonmetallic pressure-containing or pressure-controlling parts shall require a written material specification.

6.2.2 Metallic Requirements

The manufacturer's written specified requirements for metallic materials for bodies, bonnets, end and outlet connectors, stems, valve bore sealing mechanisms, and mandrel hangers shall define the following, along with accept/reject criteria:

- mechanical property requirements;
- material qualification;
- heat-treatment procedure, including cycle time, quenching practice, and temperatures with tolerances and cooling media;
- material composition with tolerances;
- NDE requirements;
- allowable melting practice(s);
- forming practice(s), including hot working, hot isostatic pressing, and cold working practices;
- heat-treating equipment calibration.

6.2.3 Nonmetallic Requirements

Nonmetallic pressure-containing or pressure-controlling seals in contact with retained fluids shall have written material specifications. The manufacturer's written specified requirement for nonmetallic materials shall define the following:

- generic base polymer(s) (see ASTM D1418), if applicable;

NOTE Reference to generic base polymer does not apply to graphite material.
- physical property requirements;
- material qualification that shall meet the equipment class requirement;
- storage and age-control requirements.

6.3 Bodies, Bonnets, and End and Outlet Connectors

6.3.1 Materials

6.3.1.1 Application

All bodies, bonnets, and end and outlet connectors shall be fabricated from standard or nonstandard (see 6.3.1.2) materials. Standard material qualification testing shall satisfy the requirements of 6.3.2.

6.3.1.2 Nonstandard Materials

Nonstandard materials for parts shown in Table 7 shall have a specified minimum yield strength at least equal to that of the lowest-strength standard material permitted for that application.

Nonstandard materials shall be materials with properties that do not meet all the requirements of Table 8 for a standard material. Nonstandard material shall conform to the manufacturer's written specification that shall include minimum requirements for:

- tensile strength (see 6.3.2.2);
- yield strength;
- hardness;
- impact strength, as applicable (see 6.3.2.3);
- a minimum of 15 % elongation;
- a minimum of 20 % reduction of area.

Table 7—Standard and Nonstandard Material Applications for Bodies, Bonnets, and End and Outlet Connectors

Part	Material Designations for Pressure Ratings ^a					
	13.8 MPa (2000 psi)	20.7 MPa (3000 psi)	34.5 MPa (5000 psi)	69.0 MPa (10,000 psi)	103.5 MPa (15,000 psi)	138.0 MPa (20,000 psi)
	Body ^b , Bonnet					
	36K, 45K 60K, 75K, NS	36K, 45K 60K, 75K, NS	36K, 45K 60K, 75K, NS	36K, 45K 60K, 75K, NS	45K, 60K 75K, NS	60K, 75K NS
	Integral End Connector					
Flanged	60K, 75K, NS	60K, 75K, NS	60K, 75K, NS	60K, 75K, NS	75K, NS	75K, NS
Threaded	60K, 75K, NS	60K, 75K, NS	60K, 75K, NS	NA	NA	NA
Other ^c	PMR	PMR	PMR	PMR	PMR	PMR
	Loose Connector					
Weld-neck	45K	45K	45K	60K, 75K, NS	75K, NS	75K, NS
Blind	60K, 75K, NS	60K, 75K, NS	60K, 75K, NS	60K, 75K, NS	75K, NS	75K, NS
Threaded	60K, 75K, NS	60K, 75K, NS	60K, 75K, NS	NA	NA	NA
Other ^c	PMR	PMR	PMR	PMR	PMR	PMR
FOOTNOTES						
^a "NS" indicates nonstandard materials as specified in 6.3.1.2.						
^b If end connectors are of the material designation indicated, design is in accordance with Section 5 and welding is in accordance with Section 7.						
^c As specified by the manufacturer.						

Table 8—Standard Material Property Requirements for Bodies, Bonnets, and End and Outlet Connectors

Material Designation	0.2 % Offset Yield Strength min. MPa (psi)	Tensile Strength min. MPa (psi)	Elongation in 50 mm (2 in.) min. %	Reduction in Area min. %
36K	248 (36,000)	483 (70,000)	21	No requirement
45K	310 (45,000)	483 (70,000)	19	32
60K	414 (60,000)	586 (85,000)	18	35
75K	517 (75,000)	655 (95,000)	17	35

6.3.2 Material Qualification Testing

6.3.2.1 General

If minimum tensile and/or impact properties are required for material to be qualified for service, the required tests shall be performed on specimens from a qualification test coupon (QTC) as described in 6.4.

6.3.2.2 Tensile Testing

6.3.2.2.1 Test Method

Tensile tests shall be performed at a temperature between 4 °C and 50 °C (between 40 °F and 120 °F) in accordance with the procedures specified in ISO 6892-1 or ASTM A370.

A minimum of one tensile test shall be performed. The results of the tensile test(s) shall satisfy the applicable requirements of Table 8.

6.3.2.2.2 Retesting

If the results of the tensile test(s) do not satisfy the applicable requirements, two additional tests on tensile specimens removed from the required location within the same QTC with no additional heat-treatment may be performed to qualify the material, and the results of each of these tests shall satisfy the applicable requirements.

6.3.2.3 Impact Testing

6.3.2.3.1 Test Specimens

Impact test of a QTC shall be used to qualify a heat and the bodies, bonnets, and end and outlet connectors produced from that heat and shall conform to the requirements of Table 9.

If subsize specimens are used, the Charpy V-notch impact requirements shall be equal to that of the 10 mm x 10 mm specimens multiplied by the adjustment factor listed in Table 10.

For PSL 4, subsize specimens shall not be used.

Table 9—Charpy V-notch Impact Requirements—10 mm x 10 mm

Temperature		Minimum Average Impact Value, J (ft-lb)			
		Transverse Direction		Longitudinal Direction	
		Wrought or Cast Material, Weld Qualification		Alternate Method for Wrought Materials Only	
Class	Test °C (°F)	PSL 1 and PSL 2	PSL 3 and PSL 4	PSL 1 and PSL 2	PSL 3 and PSL 4
K	-60 (-75)	20 (15)	20 (15)	27 (20)	27 (20)
L	-46 (-50)	20 (15)	20 (15)	27 (20)	27 (20)
N	-46 (-50)	20 (15)	20 (15)	27 (20)	27 (20)
P	-29 (-20)	20 (15)	20 (15)	27 (20)	27 (20)
S	-18 (0)	—	20 (15)	—	27 (20)
T	-18 (0)	—	20 (15)	—	27 (20)
U	-18 (0)	—	20 (15)	—	27 (20)
V	-18 (0)	—	20 (15)	—	27 (20)

Table 10—Adjustment Factors for Subsize Impact Specimens (PSL 1 to PSL 3)

Specimen Dimension	Adjustment Factor	Minimum Average Impact Value	
		Transverse Direction Wrought and Castings J (ft-lb)	Longitudinal Direction Wrought ^a J (ft-lb)
10 mm x 10 mm (full size)	1 (none)	20 (15)	27 (20)
10 mm x 7.5 mm	0.833	17 (13)	23 (17)
10 mm x 6.7 mm	0.780	16 (12)	21 (16)
10 mm x 5.0 mm	0.667	13 (10)	18 (13)
10 mm x 3.3 mm	0.440	9 (7)	12 (9)
10 mm x 2.5 mm	0.333	7 (5)	9 (7)

FOOTNOTE
^a Castings have no directionality.

6.3.2.3.2 Test Method

Impact tests shall be performed in accordance with the procedures specified in ASTM A370 or ISO 148-1 using the Charpy V-notch technique. When using ISO 148-1, a striker with a radius of 8 mm shall be used.

NOTE 1 Refer to ISO 148-1 for further details.

To qualify material for a temperature rating, impact tests shall be performed at or below the lowest temperature shown in Table 9 for that temperature range.

Three impact specimens shall be tested to qualify a heat of material. Impact properties as determined from these tests shall satisfy the applicable requirements of Table 9 or Table 10. In no case shall an individual impact value fall below two-thirds of that required as a minimum average. No more than one of the three test results shall be below the required minimum average.

NOTE 2 Where no acceptance criteria are shown in Table 9, impact testing is not required.

6.3.2.3.3 Retesting

If a test fails, then a retest of three additional specimens removed from the required location within the same QTC, with no additional heat-treatment, may be made, each of which shall exhibit an impact value equal to or exceeding the required minimum average value of Table 9 or Table 10.

6.3.2.3.4 Specimen Orientation

The values listed in Table 9 and Table 10 shall be the minimum acceptable values for wrought materials

tested in the transverse direction, and for castings and weld qualifications.

Wrought materials may be tested in the longitudinal direction instead of the transverse direction and shall meet the requirements of Table 9 and Table 10.

Castings have no directionality; the values of the transverse direction of Table 9 and Table 10 shall apply.

6.3.3 Processing

6.3.3.1 Casting Practices

For PSL 1, all castings used for bodies, bonnets, and end and outlet connectors shall meet the applicable requirements of Section 6 and Section 10. The casting practices shall be qualified to casting specification level (CSL) 2 foundry qualification requirements in API 20A, as a minimum.

For PSL 2 and PSL 3, all castings used for bodies, bonnets, and end and outlet connectors shall meet the applicable requirements of Section 6 and Section 10. The casting practices shall be qualified to CSL 3 foundry qualification requirements in API 20A.

NOTE 1 For PSL 4, this section does not apply as only wrought material is permitted.

NOTE 2 The production sampling in Section 10 for PSL 1 and PSL 2 bodies, bonnets, and end and outlet connectors is intended to monitor control of casting practices.

6.3.3.2 Hot Working Practices

For PSL 1, PSL 2, PSL 3, and PSL 4, all wrought materials shall be formed using hot working practices that produce a wrought structure throughout (see 6.4.3.1.3).

6.3.3.3 Melting Practices

For PSL 1, PSL 2, and PSL 3, the manufacturer shall specify melting practices.

For PSL 4, the melting practice requirements shall be identical to those for PSL 1, PSL 2, and PSL 3 with the addition that the manufacturer shall document the melting practice used for PSL 4 material.

6.3.4 Heat-treating

6.3.4.1 Equipment

All heat-treatment operations shall be performed using equipment qualified in accordance with the requirements specified by the manufacturer. The requirements for the heat-treating furnace survey shall conform to Annex M.

6.3.4.2 Temperature

For PSL 1, PSL 2, and PSL 3, time at temperature and thermal cycles shall conform to the manufacturer's heat-treatment specifications.

For PSL 4, the following shall apply.

- The temperature requirements of PSL 1, PSL 2, and PSL 3 shall apply with the addition that the temperature levels for PSL 4 parts shall be determined by using a heat sink.

NOTE 1 For alloy materials that are processed in accordance with API 6ACRA, temperature levels may be monitored using a contact thermocouple.

- The heat sink shall be made of the same class of material if the parts are made of an alloy of the following classes: carbon steel, alloy steel, stainless steel, titanium-based alloy, nickel-copper alloys, and nickel-based alloys.
- For parts that do not meet one of the preceding classes, the heat sink shall be made from the same alloy as the part. The equivalent round (ER) section of all heat sinks shall be determined in accordance with

the methods of 6.4.2. The ER of the heat sink shall be greater than or equal to the largest ER of any single part in a heat-treatment load.

NOTE 2 As an alternative, a production part may serve as the heat sink, provided all the requirements of 6.3.4.2 are satisfied.

The temperature-sensing tip of the thermocouple shall be within the part or heat sink and be no closer than 25 mm (1 in.) to any external or internal surface.

6.3.4.3 Quenching (for Quenched and Tempered Materials)

6.3.4.3.1 Water Quenching

The temperature of the water shall not exceed 38 °C (100 °F) at the start of the quench. For bath-type quenching, the temperature of the water shall not exceed 49 °C (120 °F) at any time during the quench cycle.

6.3.4.3.2 Other Quenching Media

The temperature range of other quenching media, such as oil or polymer, shall meet the manufacturer's written specification.

6.3.5 Chemical Composition

6.3.5.1 General

The manufacturer shall specify the nominal chemical composition, including composition tolerances, of the material. Material composition shall be determined on a heat basis (or a remelt-ingot basis for remelt-grade materials) in accordance with a nationally or internationally recognized standard.

6.3.5.2 Composition Limits—Requirements

Bodies, bonnets, and end and outlet connectors manufactured from carbon, low-alloy, and martensitic stainless steels (other than precipitation-hardening types) shall conform to the compositional limits given in Table 11 and Table 12.

Table 11—Steel Composition Limits for Bodies, Bonnets, and End and Outlet Connector Materials

Alloying Element	Composition Limits % mass fraction		
	Carbon ^a and Low-alloy ^b Steels	Martensitic Stainless Steels	45K Material for Weld-neck Flanges ^c
Carbon	0.45 max.	0.15 max.	0.35 max.
Manganese	1.80 max.	1.00 max.	1.05 max.
Silicon	1.00 max.	1.50 max.	1.35 max.
Phosphorus	^d	^d	0.05 max.
Sulfur	^d	^d	0.05 max.
Nickel	1.00 max. ^e	NA	NA
Chromium	2.75 max.	11.0–14.0	NA
Molybdenum	1.50 max.	1.00 max.	NA
Vanadium	0.30 max.	NA	NA

FOOTNOTES

^a Alloy of carbon and iron containing a maximum of 2 % mass fraction carbon, 1.65 % mass fraction manganese, and residual quantities of other elements, except those intentionally added in specific quantities for deoxidation (usually silicon and/or aluminum).

^b Steel containing less than 5 % mass fraction total alloying elements, or steels with less than 11 % mass fraction chromium, but more than that specified for carbon steel.

^c For each reduction of 0.01 % below the specified carbon maximum (0.35 %), an increase of 0.06 % manganese above the specified maximum (1.05 %) is permitted up to a maximum of 1.35 %.

^d See Table 12.

^e 1.00 max. nickel is for sour-service applications meeting NACE MR0175/ISO 15156. For nonsour service, a nickel content of 3.00 max. is acceptable.

Table 12—Phosphorus and Sulfur Concentration Limits

Product Specification Level	Part % mass fraction	
	Phosphorus	Sulfur
PSL 1	0.040 max.	0.040 max.
PSL 2	0.040 max.	0.040 max.
PSL 3	0.025 max.	0.025 max.
PSL 4	0.015 max.	0.010 max.

NOTE Table 11 and Table 12 do not apply to other alloy systems. Composition limits of other alloy systems are purposely omitted from these tables to provide the manufacturer with freedom to use alloy systems for the multiplicity of requirements encountered.

If the composition is specified by reference to a recognized industry standard, it shall not be necessary that those elements specified as residual/trace elements be reported, provided the residual/trace element limits of the industry standard are within the limits of this specification.

6.3.5.3 Tolerance Ranges

If the manufacturer specifies a material for PSL 3 or PSL 4 with chemical composition requirements by reference to a recognized industry standard, the material shall meet the tolerance ranges of the referenced industry standard. If the manufacturer specifies a material chemistry not covered by a recognized industry standard, the tolerance ranges shall meet the requirements in Table 13.

NOTE These tolerances apply only to the materials covered in Table 11.

Table 13—Maximum Tolerance Range Limits for Alloying Elements (PSL 3 and PSL 4)

Element	Maximum Tolerance Range ^a for Alloying Elements % mass fraction		
	Carbon and Low-alloy Steel	Martensitic Stainless Steels	45K Material for Weld-neck Flanges
Carbon	0.08	0.08	NA
Manganese	0.40	0.40	NA
Silicon	0.30	0.35	NA
Nickel	0.50	1.00	NA
Chromium	0.50	NA	NA
Molybdenum	0.20	0.20	NA
Vanadium	0.10	0.10	NA

FOOTNOTE
^a Values are the total allowable variation in any one element and shall not exceed the maximum specified in Table 11.

6.4 Qualification Test Coupons

6.4.1 General

The properties exhibited by the QTCs shall represent the properties of the thermal response of the material comprising the production parts it qualifies.

NOTE 1 Depending on the hardenability of a given material, the QTC results might not always correspond to the properties of the actual parts at all locations throughout their cross-section.

NOTE 2 API 6HT provides guidance and good practices for heat-treatment of parts with large cross-section, with the goal of achieving the required mechanical properties at the depth below the surface established by the manufacturer. API 20H is a standard for the qualification of batch-type heat-treatment services.

For material heat-treated in a continuous furnace, the QTC shall consist of a sacrificial production part or a

prolongation removed from a production part. The sacrificial production part or prolongation QTC shall qualify only production parts having an identical size and shape.

NOTE 3 For batch heat-treatment only, if the QTC is a trepanned core or prolongation removed from a production part, the QTC may qualify only production parts having the same or smaller ER.

NOTE 4 A sacrificial production part may be usable depending on the size and location of the test specimen from which it is selected.

For material heat treated in a batch furnace, the QTC shall qualify only material and parts produced from the same heat. For material heat treated in a continuous furnace, the QTC shall qualify only material and parts produced from the same heat and heat-treat lot.

When a prolongation is used, it shall remain integrally attached during all heat-treatment operations, except post-weld heat-treatment, stress relief, and any re-tempering or re-aging that can be required.

For tubular parts, bar stock, mill shapes, and other raw material with a uniform cross-section, the prolongation shall have the same cross-section as that of the raw material.

For a production part with a complex shape or varying cross-section, it is not necessary that the prolongation be an extension of the largest cross-section of the part, but the extension shall meet or exceed the minimum ER required for a separate QTC.

6.4.2 Equivalent Round

6.4.2.1 Selection

The size of a QTC for a part shall be determined using the ER methods given in 6.4.2.2.

6.4.2.2 ER Methods

Typical basic models for determining the ER of simple solid and hollow parts and more complicated parts shall apply as illustrated in Figure 4.

The ER of a studded type part shall be determined by using a thickness, T , equal to that of the thickest flange of that part. An ER determination for these parts shall be in accordance with the methods for complex-shaped parts.

6.4.2.3 Size Requirements

6.4.2.3.1 Castings

For PSL 1, PSL 2, and PSL 3, the ER of the QTC shall be equal to or greater than the dimensions of the part it qualifies as determined by using the actual dimensions of the part in the "as-heat-treated" condition.

6.4.2.3.2 Forgings

For PSL 1 and PSL 2, for parts with an ER of less than 63 mm (2.5 in.), the ER of the QTC shall be equal to or greater than the dimensions of the part it qualifies.

For PSL 1 and PSL 2, for parts with an ER of 63 mm (2.5 in.) or larger, the QTC size shall be 63 mm (2.5 in.) ER as a minimum, regardless of part size.

NOTE 1 A QTC larger than 63 mm (2.5 in.) ER may be used when required by the manufacturer or purchaser.

For PSL 3, for parts with an ER of less than 127 mm (5 in.), the ER of the QTC shall be equal to or greater than the dimensions of the part it qualifies.

For PSL 3, for parts with an ER of 127 mm (5 in.) or larger, the QTC size shall be 127 mm (5 in.) ER as a minimum, regardless of part size, with the exception for bodies noted in the following.

NOTE 2 A QTC larger than 127 mm (5 in.) ER may be used when specified by the manufacturer or purchaser.

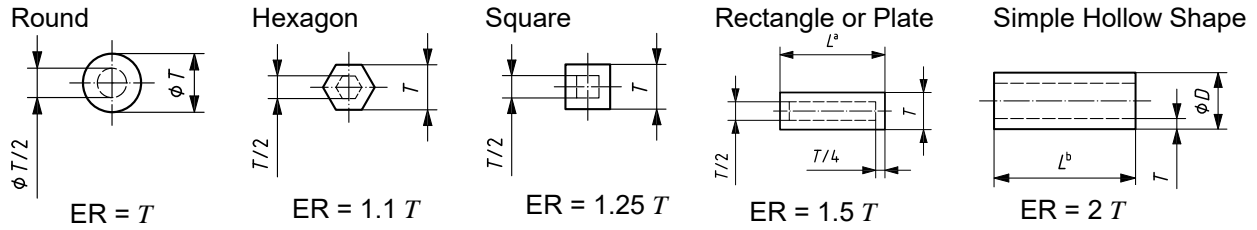

- a When L is less than T , consider section as a plate of L thickness. Area inside dashed lines is the $1/4 T$ envelope for test specimen removal.
- b When L is less than D , consider as a plate of T thickness.

a) Simple geometric ER sections/shapes having length, L

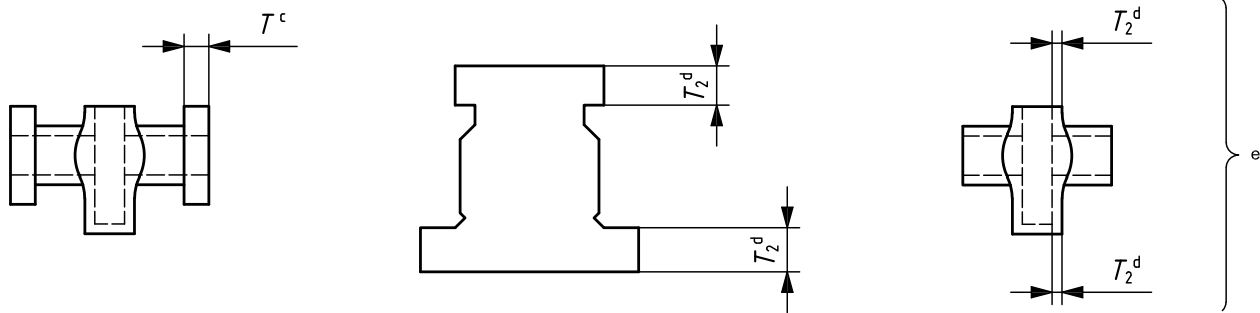

- c On multiflanged parts, T shall be the thickness of the thickest flange.
- d Where T is the thickness when the part is heat-treated as in T_2 , the larger of the two indicated dimensions shall be used.
- e Bodies with screwed and open ends.

FOOTNOTE

When all internal and external surfaces during heat-treatment are within 13 mm ($1/2$ in.) of the final surfaces, $ER = 1\frac{1}{4} T$. When all internal and external surfaces during heat-treatment are not within 13 mm ($1/2$ in.) of the final surfaces, then $ER = 2 T$.

b) General flanged bodies for complex-shaped wellhead parts

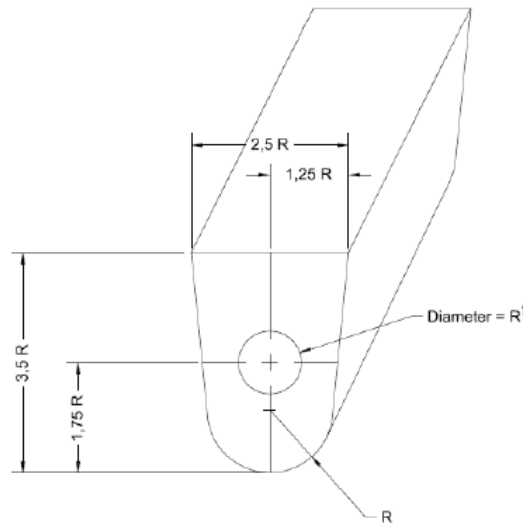

- f This area is the center core $1/4 T$ envelope for test specimen removal.

c) Keel block configuration, ER equals $2.3 R$

Figure 4—Equivalent Round Models

For PSL 3, for bodies that require a yield strength of 75K or greater and where the part's weight during heat-treat is greater than 454 kg (1000 lb), the QTC ER shall be the same or greater than the part it qualifies

but is not required to exceed 254 mm (10 in.), with the following exception.

EXCEPTION At the manufacturer's option, a 127 mm (5 in.) ER QTC shall be permitted for parts with an ER greater than 127 mm (5 in.) provided that:

- design documentation provides the stress distribution and demonstrates that the part meets the design acceptance criteria of Section 5 where the mechanical properties are lower than the requirements specified in 6.3 for the QTC;
- a qualification forging or a sacrificial part is used to validate the mechanical properties that satisfy the acceptance criteria of the analysis at a depth of 63 mm (2.5 in.) or T/4, whichever is less, at the critical cross-section(s) as identified by the stress distribution in the design documentation;
- a qualification forging or a sacrificial part is used to document that the part meets the Charpy impact requirements of this specification at a depth of 63 mm (2.5 in.) or T/4 of the thickest section of the parts, whichever is less; and
- a qualification forging or sacrificial part that shall qualify all the production parts covered by the analysis using the same heat-treat geometry, material grade, and heat-treat parameters as defined by the manufacturer.

NOTE 3 A QTC larger than 254 mm (10 in.) ER may be used when specified by the manufacturer or purchaser.

For PSL 4, a prolongation or production part shall be used.

6.4.3 Processing

6.4.3.1 Melting, Casting, and Hot Working

6.4.3.1.1 Melting Practices

In no case shall the QTC be processed using a melting practice(s) cleaner than that of the material it qualifies [e.g. a QTC made from a remelt-grade or vacuum-degassed material shall not qualify material from the same primary melt that has not experienced the identical melting practice(s)]. Remelt-grade material removed from a single remelt ingot may be used to qualify other remelt-grade material that is from the same primary melt; no additional alloying shall be performed on these individual remelt ingots. However, remelt-grade (consumable electrode process) material used to fabricate parts having a PSL 4 shall be qualified on a remelt-ingot basis.

6.4.3.1.2 Casting Practices

The manufacturer shall use the same foundry practice(s) for the QTC as those used for the parts it qualifies to ensure accurate representation.

6.4.3.1.3 Hot Working Practices

The manufacturer shall use on the QTC hot work ratios that are equal to or less than those used in processing the production part(s) it qualifies. The total hot work ratio for the QTC shall not exceed the total hot work ratio of the part(s) it qualifies.

NOTE API 20B and API 20C provide guidance on hot work ratios.

6.4.3.2 Welding

Welding on the QTC shall not be permitted, except for attachment-type welds.

6.4.3.3 Heat-treating

6.4.3.3.1 Batch-type Furnace Heat-treatment

Batch heat-treatment shall be performed using equipment qualified in accordance with 6.5.

For PSL 1 and PSL 2, the QTC shall experience the same specified heat-treatment processing as the part(s) it qualifies. The QTC shall be heat-treated using the manufacturer's specified heat-treating procedure(s). If the QTC is not heat-treated as part of the same heat-treatment lot as the part(s) it qualifies, the austenitizing, solution-treating, or age-hardening (as applicable) temperatures for the QTC shall be within 14 °C (25 °F) of those for the part(s). The tempering temperature for the part(s) shall not be lower than 14 °C (25 °F) below that of the QTC. The upper limit shall not be higher than that permitted by the heat-treat procedure for that material. The cycle time at each temperature shall not exceed that for the part(s).

For PSL 3, for mandrel hangers that use a material designation of 75K or greater and for bodies that use a material designation of 75K or greater and where the weight of the body during heat-treat is greater than 454 kg (1000 lb), the QTC shall be heat-treated in the same heat-treat furnace and same quench tank as the production parts that it qualifies.

For all parts not specifically addressed under PSL 3, the requirements of PSL 1 and PSL 2 shall apply.

For PSL 4 only, the mechanical testing shall be performed per heat per heat-treat lot. The testing shall use a prolongation or production part for each heat-treat lot. Individual prolongations or production parts corresponding to each quench shall be used for multiple quench batches from the same furnace load.

NOTE The batch heat-treatment requirements of PSL 4 do not apply to PSL 1, PSL 2, and PSL 3.

6.4.3.3.2 Continuous-type Furnace Heat-treatment

Continuous heat-treatment shall be performed using equipment qualified in accordance with 6.5.

For material heat-treated in a continuous furnace, the QTC shall be from the same heat and heat-treat lot as the material it qualifies.

6.4.4 Material Qualification

6.4.4.1 Tensile and Impact Test Specimens

If tensile and/or impact test specimens are required, they shall be removed from a QTC after the final QTC heat-treatment cycle.

NOTE 1 Multiple QTCs may be used, provided that all the applicable QTC requirements of this specification are satisfied.

Test specimens shall be removed from the QTC such that their longitudinal centerline axis is wholly within the center core $1/4T$ envelope for a solid QTC or within 3 mm ($1/8$ in.) of the mid-thickness of the thickest section of a hollow QTC (see Figure 4).

NOTE 2 For QTCs larger than the size specified in 6.4.2.3, it is not necessary that the test specimens be removed from a location farther from the QTC surface than would be required if the specified QTC size were used.

Test specimens shall be removed from the QTC such that the tensile specimen gauge length and Charpy V-notch root are at least $1/4T$ from the ends of the QTC.

If a production part is used as a QTC, the test specimens shall be removed from a section of the part meeting the size requirements for a QTC for that production part as defined in 6.4.2.

ASTM A370 standard-sized, 12.5 mm (0.500 in.) diameter tensile specimens shall be used, unless the physical configuration of the QTC prevents their use.

NOTE 3 In the instance that standard-sized specimens cannot be used because of the physical configuration of the QTC, the subsize specimens referenced in ASTM A370 may be used.

Standard-sized impact specimens, 10 mm x 10 mm in cross-section, shall be used, except where there is insufficient material, in which case the next smaller standard-sized specimen obtainable shall be used. Impact specimens shall be removed such that the notch is within the $1/4T$ envelope.

Unless specified otherwise, tensile testing shall be performed at a temperature between 4 °C and 50 °C (between 40 °F and 120 °F).

6.4.4.2 Hardness Testing

At least one Rockwell or Brinell hardness test shall be performed on the QTC after the final heat-treatment cycle.

The QTC heat-treatment cycles prior to hardness testing shall be the same heat-treatment cycles experienced by the tensile and impact test specimens. Hardness testing shall be performed in accordance with the procedures in ISO 6506 (all parts) or ISO 6508 (all parts), or ASTM E10, ASTM E18, or ASTM E110.

6.5 Production Heat-treating Equipment

6.5.1 General

For all heat-treating of parts, QTCs shall be performed with “production type” equipment meeting the requirements of this specification.

“Production type” heat-treating equipment shall be considered equipment that is routinely used to process production parts having an ER equal to or greater than the ER of the subject QTC.

Heat-treatment of production parts shall be performed with heat-treating equipment that satisfies one of the following:

- Equipment has been calibrated in accordance with 6.5.2 and 6.5.3 and surveyed in accordance with Annex M and 6.5.4.1 for batch type furnaces; or,
- Equipment has been calibrated and surveyed in accordance with SAE AMS 2750 Class 1, 2 or 3 for tempering and Class 1, 2, 3, 4 or 5 for normalizing and austenitizing.

Automatic controlling and recording instruments shall be used.

Thermocouples shall be placed in the furnace working zone(s) and protected from furnace atmospheres by means of suitable protective devices.

6.5.2 Instrument Accuracy

The controlling and recording instruments used for the heat-treatment processes shall be accurate to $\pm 1\%$ of their full-scale range.

6.5.3 Instrument Calibration

Temperature-controlling and recording instruments shall be calibrated at least once every 3 months. Equipment used to calibrate the production equipment shall be accurate to $\pm 0.25\%$ of full-scale range.

6.5.4 Production Type Equipment—Batch-type Furnaces

6.5.4.1 Furnace Survey Temperature Tolerance

6.5.4.1.1 Austenitizing, Normalizing, Annealing, or Solution Annealing Furnaces

The following criteria shall be satisfied when performing a temperature survey in accordance with Annex M.

The temperature at any point in the working zone of a furnace used for austenitizing, normalizing, annealing, or solution annealing shall not vary by more than $\pm 14\text{ °C}$ ($\pm 25\text{ °F}$) from the furnace set-point temperature after the furnace working zone has been brought up to temperature. Before the furnace set-point temperature is reached, none of the temperature readings shall exceed the set-point temperature by more than the temperature tolerance.

6.5.4.1.2 Tempering, Aging, or Stress-relieving Furnaces

The following criteria shall be satisfied when performing a temperature survey in accordance with Annex M.

Furnaces that are used for tempering, aging, and/or stress-relieving shall not vary by more than ± 8 °C (± 15 °F) from the furnace set-point temperature after the furnace working zone has been brought up to temperature. Before the furnace set-point temperature is reached, none of the temperature readings shall exceed the set-point temperature by more than the temperature tolerance.

6.5.4.1.3 Multiple Use Furnaces

For furnaces used for heat-treatment operations identified in 6.5.4.1.1 and 6.5.4.1.2, the heat-treatment supplier shall define the temperature range for each operation. The furnace temperature uniformity survey shall conform to the requirements specified in 6.5.4.1.1 and 6.5.4.1.2, as appropriate for the process used.

6.5.4.2 Temperature Uniformity Survey Frequency

The following criteria shall be satisfied when performing a temperature survey in accordance with Annex M.

The temperatures within each batch-type furnace shall be surveyed within 1 year prior to use of the furnace for heat-treatment.

6.5.4.3 Furnace Repairs

When a furnace is repaired or rebuilt, a new temperature survey shall be carried out before the furnace is used for heat-treatment, subject to the following. Repairs that return the furnace to the condition it was in at the time of the previous furnace survey and calibration or repairs that do not affect the temperature tolerance of the furnace shall not require a new temperature survey and calibration.

The SAE AMS2750 sections on furnace modifications and furnace repairs shall be used to determine whether a new furnace survey is required. All furnace repairs and modifications shall be documented, and the responsible quality assurance organization shall make determination whether an additional furnace survey and calibration is required based on the repairs or modifications in accordance with SAE AMS2750 or SAE AMS-H-6875.

6.5.5 Production Type Equipment—Continuous-type Furnaces

Continuous-type furnaces shall be operated, maintained, modified, and repaired in accordance with SAE AMS2750 or SAE AMS-H-6875.

Continuous-type furnaces shall be surveyed in accordance with Annex M.

7 Welding

7.1 General

Section 7 shall not apply to material surface property controls, such as thermal spray processes [e.g. high-velocity oxygen fuel (HVOF)].

7.2 Nonpressure-containing Welds Other Than Weld Overlays

7.2.1 Welding Procedure/Performance

For PSL 1, PSL 2, PSL 3, and PSL 4, welding procedures and performance qualifications shall be in accordance with the following:

- ASME *BPVC*, Section IX, or
- ISO 15609 (procedures), applicable parts of ISO 15614 (qualification testing), and applicable parts of ISO 9606 [welder performance qualification (WPQ)].

7.2.2 Application

For PSL 1, PSL 2, PSL 3, and PSL 4, the following shall apply.

- Welding shall be performed in accordance with qualified procedures by qualified welding personnel. Nonpressure-containing welds shall meet the manufacturer's design requirements.
- For welding performed in accordance with ISO qualified welding procedures, welding work and related activities should follow requirements in the relevant parts of ISO 3834. As a minimum, ISO 3834-Part 3 shall be adhered to in addition to specific requirements as established in this specification.

7.3 Pressure-containing Fabrication Welds

7.3.1 General

Fabrication welding shall not be performed on bullplugs and valve-removal plugs.

7.3.2 Joint Design

For PSL 1, PSL 2, PSL 3, and PSL 4, design of groove and fillet welds with tolerances shall be documented in the manufacturer's specifications.

7.3.3 Materials

7.3.3.1 Welding Consumables

For PSL 1, PSL 2, PSL 3, and PSL 4, welding consumables shall conform to the requirements of the welding procedure specification (WPS). The manufacturer shall have a written procedure for storage and control of welding consumables. Welding consumables shall be stored and used as recommended by the manufacturer of the welding consumable.

7.3.3.2 Deposited Weld Metal Properties

For PSL 1, PSL 2, PSL 3, and PSL 4, the deposited weld metal mechanical properties, as determined by the procedure qualification record (PQR), shall meet or exceed the mechanical properties specified for the design of the part.

7.3.4 Welding Procedure Qualifications

7.3.4.1 Written Procedure

For PSL 1, PSL 2, PSL 3, and PSL 4, the following shall apply.

- Welding shall be performed in accordance with WPS, written and qualified in accordance with ASME *BPVC*, Section IX or ISO 15609. The WPS shall be qualified by use of welding procedure test as required in ASME *BPVC*, Section IX or ISO 15614-1. The WPS shall describe all the essential, nonessential, and supplementary essential variables.
- The PQR (ASME *BPVC*, Section IX) or welder performance qualification record (WPQR) (ISO 15614-1) shall record all essential and supplementary essential (if required) variables of the weld procedure used for qualification testing. Both the WPS and the PQR shall be maintained as records in accordance with the requirements of Section 15.

NOTE In this specification, reference to WPQR (ISO 15614-1) is equivalent to PQR (ASME *BPVC*, Section IX).

7.3.4.2 Base Metal Groupings

For PSL 1, PSL 2, PSL 3, and PSL 4, the following shall apply.

- For welding procedures in accordance with ASME *BPVC*, Section IX, base material(s) not listed in P-number grouping shall be specifically qualified by the manufacturer.
- For welding procedures in accordance with applicable parts of ISO 15614, grouping shall be as defined by applicable parts of ISO 15614.

7.3.4.3 Heat-treatment

For PSL 1 and PSL 2, if post-weld heat-treatment is required by the WPS, all testing shall be done with the test weldment in the post-weld heat-treated condition. Post-weld heat-treatment of the test weldment shall be in accordance with the manufacturer's written specifications.

For PSL 3 and PSL 4, in addition to the requirements for PSL 1 and PSL 2, the post-weld heat-treatment of the test weldment shall be in the same temperature range as that specified on the WPS. The difference between the upper and lower allowable temperature limits shall not exceed 28 °C (50 °F).

7.3.4.4 Hardness Testing

For PSL 1, PSL 2, PSL 3, and PSL 4, the following shall apply.

- For material classes DD, EE, FF, and HH, hardness tests across the weld and base-material heat-affected zone (HAZ) cross-section shall be performed and recorded as part of the PQR. Hardness test locations and results shall be in accordance with NACE MR0175/ISO 15156.
- For material classes AA, BB, and CC, the manufacturer shall specify the hardness testing locations. Testing shall be performed on the weld and base-material HAZ cross-section in accordance with ASTM E18 or ISO 6508 (all parts), Rockwell method; or ISO 6507 (all parts), using the 98 N method or ASTM E92 Vickers 10 kgf method. Results shall be converted to Rockwell C, as applicable. ASTM E140 or ISO 18265 shall be used for the conversion of hardness readings for materials within the scope of their application.

NOTE 1 Other correlations may be established for individual materials that are outside the scope of ISO 18265 or ASTM E140.

- When a conversion other than ASTM E140 or ISO 18265 conversion is used, the conversion method shall be documented and shall be based on validated test results. The measured hardness and test scale shall be reported in parentheses.

NOTE 2 For example, 20.0 HRC (228 HBW), where 20.0 HRC is the converted hardness value and 228 HBW is the original measurement value and test scale.

7.3.4.5 Hardness Testing for Minimum Mechanical Properties

When specified by the manufacturer or purchaser, the following shall apply.

- For PSL 1, PSL 2, PSL 3, and PSL 4, for the purposes of hardness inspection and qualifying production welds, a minimum of three hardness tests in the weld metal shall be made and recorded as part of the PQR.
- The three hardness tests shall be made by the same methods as used to inspect production welds.

NOTE These tests may be used to qualify weld metal with a hardness lower than that established in 10.4.2.4.3 in accordance with the methods shown in 10.4.2.4.2.

7.3.4.6 Impact Testing

For PSL 1, PSL 2, PSL 3, and PSL 4, the following shall apply.

- If impact testing is required for the base material, the testing shall be performed in accordance with ASTM A370 or ISO 148-1 using the Charpy V-notch technique. When using ISO 148-1, a striker with a radius of 8 mm shall be used.
- Results of testing in the weld and base-material HAZ shall meet the minimum requirements of the base material. Records of results shall become part of the PQR. Any retests of impact testing shall be in accordance with ISO 148-1 or ASTM A370.
- If a test fails, then a retest of three additional specimens removed from the required location within the same test coupon (per ASME *BPVC*, Section IX) with no additional heat-treatment may be made, each of which shall exhibit an impact value equal to or exceeding the required minimum average value per Table 9 or Table 10.

For PSL 2, PSL 3, and PSL 4, the following additional impact test requirements apply.

If impact testing is required for the base material, two sets of three test specimens shall be removed: one set from the weld metal and one set from the base-material HAZ. At least one face of each specimen shall be within $\frac{1}{4}T$ of the surface of the material, where T is the thickness of the weld. The root of the notch shall be oriented normal to the surface of the test weld and located as follows:

- weld metal specimens (three each): 100 % weld metal;
- HAZ specimens (three each): to include as much HAZ material as possible.

NOTE The additional impact testing requirements do not apply to PSL 1.

7.3.4.7 Chemical Analysis

For PSL 3 and PSL 4, chemical analysis of the base materials and filler metal for the test weld shall be obtained from the supplier or by testing and shall be part of the PQR.

NOTE The requirements of 7.3.4.7 do not apply to PSL 1 and PSL 2.

7.3.5 Welder Performance Qualification

For PSL 1, PSL 2, PSL 3, and PSL 4, welders and welding operators shall be qualified in accordance with ASME *BPVC*, Section IX or ISO 9606. Records of welder WPQ tests shall be in accordance with ASME *BPVC*, Section IX or ISO 9606.

7.3.6 Welding Requirements

For PSL 1, PSL 2, PSL 3, and PSL 4, the following shall apply.

- Welding shall conform to the qualified WPS and shall be performed by qualified welders/welding operators.
- Welders and welding operators shall have access to, and shall conform to, the welding parameters as defined in the WPS.
- All welds that are considered part of the design of a production part shall be specified by the manufacturer to describe the requirements for the intended weld.
- Preheating of assemblies or parts, if required by the WPS, shall be performed in accordance with the manufacturer's written procedures.

7.3.7 Post-weld Heat-treatment

For PSL 1, the following shall apply.

- Post-weld heat-treatment shall be in accordance with the applicable qualified WPS.
- Welds may be locally post-weld heat-treated. The manufacturer shall specify procedures for the use of local post-weld heat-treatment.
- In the case of low-alloy quenched and tempered steels, the post-weld heat-treatment temperature shall be below the tempering temperature.

For PSL 2, the following shall apply.

- The requirements for PSL 1 shall apply.
- Additionally, furnace post-weld heat-treatment shall be performed with equipment meeting the requirements of Annex M.
- Additionally, local post-weld heat-treatment shall consist of heating a circumferential band around the weld at a temperature within the range specified in the qualified WPS. The minimum width of the controlled band, on each side or end of the weld, shall be the widest width of the weld plus either the nominal thickness of the part or 50 mm (2 in.), whichever is less. Heating by direct flame impingement on the material shall not be permitted.

NOTE 1 The additional post-weld heat-treatment requirements of PSL 2 do not apply to PSL 1.

For PSL 3 and PSL 4, the following shall apply.

- The requirements of PSL 2 shall apply.
- Additionally, the post-weld heat-treatment of the production weldment shall be in the same temperature range as that specified on the WPS. The stress-relieving heat-treatment time(s) at temperature of production parts shall be equal to or greater than that of the test weld.

NOTE 2 The additional post-weld heat-treatment requirements of PSL 3 and PSL 4 do not apply to PSL 1 and PSL 2.

7.3.8 Welding Controls

For PSL 1 and PSL 2, the following shall apply.

- The manufacturer's welding control system shall include procedures for monitoring, updating, and controlling the qualification of welders/welding operators and the use of WPS.
- For welding performed in accordance with ISO qualified welding procedures, welding work and related activities should follow requirements in the relevant parts of ISO 3834. As a minimum, ISO 3834-Part 3: *Standard Quality Requirements* shall be adhered to in addition to specific requirements as established in this specification.
- Instruments to indicate temperature, voltage, and amperage shall be serviced and calibrated in accordance with the manufacturer's written specifications.

For PSL 3 and PSL 4, the following shall apply.

- In addition to the requirements for PSL 1/PSL 2, instruments, meters, and gauges used to confirm welding parameters shall be serviced and calibrated to the manufacturer's written specifications by equipment traceable to a nationally or internationally recognized standard specified by the manufacturer.

- The calibration intervals shall be a maximum of 6 months until recorded calibration history can be established by the manufacturer. Intervals may be lengthened (6-month maximum increment) or shall be shortened based on the recorded history. Written records shall document the calibration date, procedure used, accuracy, frequency, and hardness results.

NOTE The additional welding control requirements of PSL 3 and PSL 4 do not apply to PSL 1 and PSL 2.

7.4 Pressure-containing Repair Welds

7.4.1 General

The requirements of 7.4 shall apply to PSL 1, PSL 2, PSL 3, and PSL 4, unless otherwise noted.

7.4.2 Welding Procedure Qualifications

7.4.2.1 General

All repair welding procedures shall define the WPS and NDE requirements.

Welding shall be performed in accordance with the specified WPS.

7.4.2.2 Base Material

The base material requirements for material composition, material designation as specified in this specification, impact strength (if required), and heat-treatment condition shall be known prior to selecting a qualified WPS.

7.4.2.3 Fusion

The WPS selected and the access for repair shall ensure complete fusion.

7.4.2.4 Procedure Qualification Record

The WPS selected shall be supported by a PQR as described in 7.3.4.

7.4.2.5 Repair Welding

Repair welding of bullplugs, valve-removal plugs, and back-pressure valves shall not be allowed.

7.4.2.6 Access

There shall be access to evaluate, remove, and inspect the nonconforming condition (see also 10.4.2.15).

7.4.2.7 Welder/Welding Operator Qualification

The welder/welding operator shall possess a valid qualification in accordance with 7.3.5.

7.4.3 Weld Repair of Castings

Weld repair for castings shall conform to the requirements of API 20A, CSL 3.

Weld repairs shall be documented in accordance with API 20A.

7.4.4 Bolt Hole, Tapped Hole, and Machined Blind Hole Repair

For PSL 2 and PSL 3, the following shall apply.

- The welder/welding operator shall perform an additional repair-welding performance-qualification test using a mock-up hole.
- The repair-welding-qualification test hole shall be qualified by radiography in accordance with 10.4.2.16 or shall be cross-sectioned through the centerline of the hole in two places 90° apart and macro-etched to confirm complete fusion. One surface of each of the four matching segments shall be macro-etched. This evaluation shall include the total depth of the hole.
- The repair-weld qualification shall be restricted by the following essential variables for performance controls.
 - a) The hole diameter used for the performance-qualification test is the minimum diameter qualified. Any hole with a diameter greater than the diameter used for the test shall be considered qualified.
 - b) The depth-to-diameter ratio of the test hole shall qualify all repairs to holes with a same or smaller depth-to-diameter ratio.
 - c) The performance-qualification test hole shall have straight parallel walls. If any taper, counterbore, or other aid is used to enhance the hole configuration of the performance test, that configuration shall be considered an essential variable.
- The requirements of 7.3.4, 7.3.7, and 7.3.8 shall also apply.

NOTE 1 The hole repair requirements of PSL 2 and PSL 3 do not apply to PSL 1 and PSL 4.

For PSL 4, weld repair of bolt holes, tapped holes, and machined blind holes shall not be permitted.

NOTE 2 The hole repair requirements of PSL 4 do not apply to PSL 1, PSL 2, and PSL 3.

7.5 Weld Overlay

7.5.1 Corrosion-resistant Overlay (Including Ring Grooves)

7.5.1.1 General

The provisions of 7.5.1 shall apply to use of corrosion-resistant weld overlay for bodies, bonnets, mandrel hangers, clamp hub end connectors, and end and outlet connectors (including ring grooves).

NOTE These requirements do not apply to hard facing or to the weld overlay of valve bore sealing mechanisms, choke trim, or valve stems.

7.5.1.2 Welding Procedure/Performance Qualification

7.5.1.2.1 General

Qualification for weld overlay shall conform to ASME *BPVC*, Section IX, for weld overlay or to ISO 15614-7.

7.5.1.2.2 Thickness

For PSL 1, PSL 2, PSL 3, and PSL 4, the following shall apply.

- The minimum thickness of the finished corrosion-resistant weld overlay applied to material class HH equipment and all other full overlay equipment shall be 3 mm (0.12 in.). The minimum thickness for ring grooves in partial overlay equipment shall be 3 mm (0.12 in.) for the outer 23° surface. The minimum thickness for all other ring groove surfaces shall be equal to or greater than the thickness requirements as established by the weld procedure qualification.

- The minimum thickness of the finished corrosion-resistant weld overlay applied to partial overlay equipment shall be equal to or greater than the thickness requirements established by the weld procedure qualification.

7.5.1.2.3 Chemical Analysis

For PSL 1, PSL 2, PSL 3, and PSL 4, the following shall apply.

- Chemical analysis shall be performed on the weld metal in accordance with the requirements of ASME *BPVC*, Section IX or ISO 15614-7. Chemical sampling of the overlay shall be performed at or less than the minimum thickness qualified. The minimum thickness qualified shall be established by the manufacturer based on the design of the finished part and within the limits specified in 7.5.1.2.2.
- Chemical analysis is also acceptable when measured from the fusion face if the production acceptance criteria measurements for clad thickness using the eddy current or Hall effect methods account for the penetration depth to the approximate weld interface. The chemical composition of the deposited weld metal at that location shall be as specified by the manufacturer.
- For the nickel-based alloy UNS N06625, the chemical composition shall meet one of the classes given in Table 14.

NOTE Either Fe5 or Fe10 may be used for any material class.

Table 14—Chemical Composition of the Nickel-based Alloy UNS N06625

Class	Element	Composition % mass fraction
Fe5	Iron	5.0 max.
Fe10	Iron	10.0 max.

- For other compositions that are required to conform to the requirements of NACE MR0175/ISO 15156, the chemical analysis of the overlay shall conform to the specification limits of the corresponding NACE MR0175/ISO 15156 approved material(s).
- Rough machining tolerances and finished machining tolerances shall be controlled to ensure that the exposed layer meets the dilution established through qualification.

7.5.1.2.4 Mechanical Properties

For PSL 1, PSL 2, PSL 3, and PSL 4, the following shall apply.

- The base metal material shall retain the minimum mechanical property requirements after post-weld heat-treatment. The manufacturer shall specify the methods to ensure these required mechanical properties and record the results as part of the PQR.
- If the overlay material is not considered as part of the manufacturer's or this specification's design requirements of Section 5.1, a tensile test and an impact test of the overlay material shall not be required.
- Other than ring grooves, if the overlay material is considered as part of the manufacturer's design requirements of Section 5.1 or where dimensions for the product are specified in this specification, mechanical testing per Section 6 of the overlay material shall be required.
- If overlay material is only part of the manufacturer's design requirements of Section 5.1, acceptance criteria for mechanical testing of the overlay material shall be as specified in Section 6, or as established by design analysis and specified by the manufacturer.

7.5.1.2.5 Weld Conformance with NACE MR0175/ISO 15156

For PSL 1, PSL 2, PSL 3, and PSL 4, welds for use in H₂S service shall conform to the requirements of NACE MR0175/ISO 15156.

7.5.1.2.6 Guided-bend Tests

For PSL 1, PSL 2, PSL 3, and PSL 4, guided-bend tests and acceptance criteria shall be in accordance with ASME *BPVC*, Section IX or ISO 15614-7 to confirm weld overlay/base material bond integrity.

7.5.1.2.7 Welder Performance Qualification

For PSL 2, PSL 3, and PSL 4, WPQs shall conform to ASME *BPVC*, Section IX; the relevant parts of ISO 9606; or ISO 14732.

NOTE The supplemental requirements of 7.5.1.2.7 do not apply to PSL 1.

7.5.1.3 Base Material Conformance with NACE MR0175/ISO 15156

For PSL 1, PSL 2, PSL 3, and PSL 4, where the base material is required to meet NACE MR0175/ISO 15156, the base material shall conform to NACE MR0175/ISO 15156 after weld overlay and any subsequent heat-treatments.

7.5.1.4 Mechanical Properties

For PSL 2, PSL 3, and PSL 4, the base material shall retain the minimum mechanical property requirements after post-weld heat-treatment. The manufacturer shall specify the methods to ensure these mechanical properties and record the results as part of the PQR.

NOTE The mechanical property requirements 7.5.1.4 do not apply to PSL 1.

7.5.1.5 Hardness Testing for Ring Groove Overlay

For PSL 2, PSL 3, and PSL 4, hardness testing shall be performed in the weld metal as part of the procedure qualification testing. Test locations shall be within 3 mm (0.12 in.) of the original base material. The average of three or more test results shall be equal to or greater than 92 HRBW and recorded as part of the PQR.

NOTE The hardness testing for ring groove overlay requirements of 7.5.1.5 do not apply to PSL 1.

7.5.2 Weld Overlay for Other Than Corrosion Resistance

For PSL 1, PSL 2, PSL 3, and PSL 4, the following shall apply.

- Weld overlay for purposes other than those covered by 7.5.1 shall require a welding procedure/performance qualification for weld overlay in accordance with ASME *BPVC*, Section IX or ISO 15614-7.
- Hard facing or other types of weld overlay for use in hydrogen-sulfide service shall conform to the requirements of NACE MR0175/ISO 15156.
- The base material shall retain the minimum mechanical property requirements after post-weld heat-treatment.
- The manufacturer shall specify the methods to ensure these mechanical properties and record the results as part of the PQR.

7.5.3 Repair of Weld Overlays

For PSL 1, PSL 2, PSL 3, and PSL 4, repairs of weld overlays, including associated base metal build-up using the overlay material, shall be acceptable only provided that:

- the original applicable requirements (see 7.5.1) are adhered to;
- when the manufacture determines that the overlay material and/or base metal build-up is part of the design requirements of Section 5.1 and proves through design analysis the functionality of the finished part, provided that the finished part is in conformance with the dimensions of this specification;
- weld overlay repairs and associated base metal build-up for use in hydrogen-sulfide service conform to the requirements of ISO 15156 (all parts) (NACE MR0175).

8 Bolting

8.1 Closure Bolting

8.1.1 Tensile Stress

The maximum tensile stress for closure bolting shall be determined considering initial bolt-up, rated operating conditions, and hydrostatic shell test pressure. Bolting stresses, based on the minimum cross-sectional area of the bolting, shall not exceed the allowable tensile stress, S_A , given in Equation (2):

$$S_A = 0.83 S_Y \quad (2)$$

where

S_Y is the bolting material-specified minimum yield strength.

Bolting stresses shall be determined considering all loading on the closure, including pressure acting over the seal area, gasket loads, and any additional mechanical and thermal loads.

NOTE Fatigue analysis is outside the scope of this specification.

8.1.2 Quality

Closure bolting shall be qualified and manufactured in accordance with API 20E or API 20F. Bolting specification levels (BSLs) shall be as specified in Table 15.

Table 15—Minimum Requirements for Closure Bolting

	API 20E	API 20F
PSL 1	BSL-1	BSL-2
PSL 2	BSL-1	BSL-2
PSL 3	BSL-1	BSL-2
PSL 4	BSL-2 (bolt nominal diameter $\leq 2\frac{1}{2}$ in.)	BSL-2 (bolt nominal diameter $\leq 2\frac{1}{2}$ in.)
PSL 4	BSL-3 (bolt nominal diameter $> 2\frac{1}{2}$ in.)	BSL-3 (bolt nominal diameter $> 2\frac{1}{2}$ in.)

8.1.3 Studded Outlet Connection

The requirements of Annex H for closure bolting shall apply only to those used to connect 6B and 6BX flanged and studded connectors as specified in 14.1.

8.1.4 Closure Bolting Records

If BSL-2 or BSL-3 is specified per Table 15, closure bolting records shall be maintained in accordance with the record requirements of API 20E or API 20F, as applicable.

8.1.5 Closure Bolting Marking

Closure bolting shall be marked in accordance with API 20E and API 20F, as applicable.

8.1.6 Impact Test Marking

If the impact test temperature is different from that specified by the ASTM specification, the actual test temperature, expressed in degrees Celsius (or degrees Fahrenheit), shall be metal-stamped directly under the grade as required by the ASTM specification. The impact test temperatures, expressed in degrees Celsius (or degrees Fahrenheit), for all corrosion-resistant alloy (CRA) material studs shall be metal-stamped directly under the "CRA" marking.

8.2 Closure Bolting for Flanged and Studded End and Outlet Connectors

8.2.1 General

The requirements of 8.2 for closure bolting shall apply only to those used to connect 6B and 6BX flanged and studded connectors as specified in 14.1.

NOTE 1 For closure bolting assembly, see Annex H.

NOTE 2 For calculations and recommendations of stud bolt length, see Annex I.

8.2.2 Design

The requirements for closure bolting shall be as shown in Table 16, Table 17, and Table 18. Closure bolting shall meet the requirements of the applicable ASTM specification.

Threads shall be in accordance with ASME B1.1, Class 2 or 3.

8.2.3 Materials

8.2.3.1 General

Bolting shall meet the requirements of the applicable ASTM specifications as shown in Table 16 and Table 17.

Alternative materials shall be acceptable if they meet the mechanical requirements of Table 16 and Table 17, and the quality requirements of 8.3.4.

Bolting that is identified as exposed bolting by the purchaser or used on equipment with material class DD, EE, FF, or HH, assembled by the manufacturer with insulated flanges, shall satisfy the requirements of 8.2.3.2 or 8.2.3.3, in addition to 8.2.3.5.

8.2.3.2 Exposed Bolting

The following apply:

- a) For ASTM A453/A453M Grade 660D

ASTM A453/A453M Grade 660D solution-treated and age-hardened bolting shall be acceptable at a hardness of HRC 35 and lower, and a minimum 0.2 % offset yield strength of 725 MPa (105,000 psi) for diameters up to 63.5 mm (2.5 in.) or 655 MPa (95,000 psi) for sizes larger than 63.5 mm (2.5 in.). Environmental and material limits specified in NACE MR0175/ISO 15156 shall apply.

- b) For CRA materials

CRA materials shall be acceptable provided they satisfy the minimum requirements of 8.2.3.2 a) for ASTM A453/A453M Grade 660D bolting, with the exception that the maximum hardness shall meet NACE MR0175/ISO 15156 requirements for the CRA used. Environmental and material limits specified in NACE MR0175/ISO 15156 shall apply.

NOTE NACE MR0175 provides material usage limits for H₂S environments. Other forms of cracking may result from the presence of chlorides (such as seawater) and or hydrogen (such as cathodic protection).

Table 16—Acceptable Closure Bolting for 6B and 6BX Flanged and Studded Connections

	Pressure Rating MPa (psi)	Nominal Size (in.)	ASTM Bolting Standard(s) and 0.2 % Offset Yield Strength			
			Nonexposed Bolting		H ₂ S-Exposed Bolting	
			A193 GR. B7 (≤ 2.5") A320 GR. L7 (≤ 2.5") A320 GR. L43 (≤ 4.0")	A193 GR. B7 (> 2.5") A320 GR. L7 (> 2.5")	A193 GR. B7M (≤ 4.0") A320 GR. L7M (≤ 2.5")	A453 GR. 660D (≤ 4.0") (See 8.2.3.2 and 8.2.3.5) CRA
			725 MPa (105 ksi)	655 MPa (95 ksi)	550 MPa (80 ksi)	725 MPa (105 ksi) ≤ 2.5" 655 MPa (95 ksi) > 2.5"
Studs, Bolts, and Cap Screws	13.8 (2000)	All sizes	✓	NA	✓	✓
	20.7 (3000)	All sizes	✓	NA	✓	✓
	34.5 (5000)	All sizes	✓	NA	✓	✓
	69.0 (10,000)	1 ³ / ₁₆ , 2 ¹ / ₁₆ , 2 ⁹ / ₁₆ , 3 ¹ / ₁₆	✓	NA	✓	✓
		4 ¹ / ₁₆	✓	NA	Unacceptable	✓
		5 ¹ / ₈	✓	NA	Unacceptable	✓
		7 ¹ / ₁₆	✓	NA	✓	✓
		9, 11, 13 ⁵ / ₈ , 16 ³ / ₄ , 18 ³ / ₄ , 21 ¹ / ₄	✓	NA	Unacceptable	✓
	103.5 (15,000)	1 ³ / ₁₆	✓	NA	✓	✓
		2 ¹ / ₁₆ , 2 ⁹ / ₁₆ , 3 ¹ / ₁₆ , 4 ¹ / ₁₆	✓	NA	Unacceptable	✓
		5 ¹ / ₈	✓	NA	✓	✓
		7 ¹ / ₁₆ , 9, 11, 13 ⁵ / ₈	✓	NA	Unacceptable	✓
		18 ³ / ₄	✓ Gr. L43 only	✓	Unacceptable	✓
	138.0 (20,000)	1 ³ / ₁₆ , 2 ¹ / ₁₆ , 2 ⁹ / ₁₆ , 3 ¹ / ₁₆ , 4 ¹ / ₁₆ , 7 ¹ / ₁₆ , 9	✓	NA	✓	✓
		11, 13 ⁵ / ₈	✓ Gr. L43 only	✓	✓ Gr. B7M only	✓
	Nuts	All pressure ratings	All sizes	ASTM A194/A194M GR. 2H, 2HM, 7, 7M		ASTM A194/A194M GR. 2HM, 7M
NOTE ✓ = acceptable.						

Table 17—Allowable Closure Bolting by Temperature Class

Temperature Class	P, S, T, U	K, L
Impact testing of studs, bolts, and screws required	No ^a	Yes
Acceptable ASTM bolting standards and grades for studs, bolts, and screws	A193/A193M GR. B7	A320/A320M GR. L7
	A320/A320M GR. L7	A320/A320M GR. L43
	A320/A320M GR. L43	A320/A320M GR. L7M
	A193/A193M GR. B7M	A453/A453M GR. 660D
	A320/A320M GR. L7M	CRA
	A453/A453M GR. 660D	—
	CRA	—
Acceptable ASTM standards and grades for nuts ^b	ASTM A194/A194M	ASTM A194/A194M
	GR. 2H, 2HM, 7, 7M	GR. 2H, 2HM, 7, 7M

FOOTNOTES

^a Impact testing is required for all studs, bolts, and screws larger than 2.50 in. thread size regardless of temperature rating.

^b Impact testing is not required for nuts.

Table 18—Threads for Closure Bolting Used on 6B and 6BX Flanged and Studded End or Outlet Connectors

ASME B1.1 Thread Designation Nominal Thread Size-TPI Series
1/2-13 UNC
5/8-11 UNC
3/4-10 UNC
7/8-9 UNC
1-8 UNC
1 1/8-8 UN
1 1/4-8 UN
1 3/8-8 UN
1 1/2-8 UN
1 5/8-8 UN
1 3/4-8 UN
1 7/8-8 UN
2-8 UN
2 1/4-8 UN
2 1/2-8 UN
2 3/4-8 UN
3-8 UN

8.2.3.3 Exposed Bolting (Low-strength)

ASTM A193/A193M Grade B7M shall be acceptable at a minimum 0.2 % offset yield strength of 550 MPa (80,000 psi) for the flanges listed in Table 16 for NACE MR0175/ISO 15156 exposed bolting (low-strength).

ASTM A320/A320M Grade L7M shall be acceptable at a minimum 0.2 % offset yield strength of 550 MPa (80,000 psi) for the flanges listed in Table 16 for NACE MR0175/ISO 15156 exposed bolting (low-strength) only. Only flanges having a bolt nominal diameter ≤ 63.5 mm (≤ 2.5 in.) are acceptable for this grade of bolting.

8.2.3.4 Nonexposed Bolting

ASTM A193/A193M Grade B7 shall be acceptable for nonexposed service for all flanges requiring a nominal bolt diameter ≤ 63.5 mm (≤ 2.5 in.) and with temperature class P, S, T, and U. All bolting > 63.5 mm (> 2.5 in.) diameter shall require impact testing.

ASTM A320/A320M Grade L7 or L43 shall be acceptable for nonexposed service for all flanges.

NOTE Bolting make-up and connection capacity can be affected by mismatching the strength of the nut to the strength of the bolt. Bolting with diameters greater than 38 mm (1.50 in.) are typically affected more than smaller bolting.

8.2.3.5 Exposed Nuts

ASTM A194/A194M Grades 2HM and 7M shall be acceptable for all flange sizes and rated working pressures.

NOTE ASTM A453/A453M Grade 660D or CRA nuts may be used with NACE MR0175/ISO 15156 exposed bolting only if provisions are made to prevent galling.

8.2.3.6 Special Caution for Offshore Bolting Service

ASTM A453/A453M Grade 660D solution-treated and age-hardened bolting as stated in 8.2.3.2 should not be used on pressure-containing and high load-bearing connectors in the following situations:

- wet/dry offshore and coastal applications in the presence of salt air;
- where it is routine to clean/wash equipment with untreated/raw seawater.

NOTE 1 Environmentally assisted cracking, such as stress corrosion cracking (SCC), may result from the presence or accumulation of chlorides from deposited salt on highly stressed austenitic stainless steel bolting, such as Grade 660D.

NOTE 2 API 6ACRA addresses alternative, higher-strength CRA materials suitable for sour exposure.

8.3 Other Closure Bolting

8.3.1 General

This section shall apply to closure bolting for uses other than API flanged and studed connections specified in 14.1.

8.3.2 Design

The design of other closure bolting shall be per 8.1 and manufacturer's requirements.

8.3.3 Materials

The material requirements shall be specified by the manufacturer. Carbon or alloy-steel bolting shall not exceed 34 HRC.

Impact testing for closure bolting shall meet the requirements of Table 17.

For exposed service, materials shall be in accordance with NACE MR0175/ISO 15156.

NOTE Carbon steel bolting can be susceptible to environmentally assisted cracking due to material processing such as hydrogen charging during plating operations or during exposure to marine environments.

8.3.4 Quality

Quality control requirements for other closure bolting shall be as specified in 8.1.2.

9 Packing Mechanisms, Pressure Boundary Penetrations, and Ports

9.1 Packing Mechanisms

9.1.1 Performance Requirements

Packing mechanisms shall meet the general requirements of 4.2 and, when installed in equipment, shall be capable of performing their intended function to applicable PR1 or PR2 requirements for the equipment in which they are used.

9.1.2 Design

The packing mechanisms shall be capable of maintaining a leak-tight seal at the rated working pressure of the head.

9.2 Fittings and Pressure Boundary Penetrations

9.2.1 General

Pressure boundary penetrations shall be capable of maintaining a leak-tight seal at the rated working pressure and temperatures.

NOTE Fittings are a type of pressure boundary penetration.

9.2.2 Performance Requirements

Pressure boundary penetrations shall be capable of meeting the general requirements of 4.2 and, when installed in equipment, shall be capable of performing their intended function to applicable PR1 or PR2 requirements for the equipment in which they are used.

9.2.3 Design

9.2.3.1 General

NOTE The design of pressure boundary penetrations is outside the scope of this specification.

9.2.3.2 Lock Screws in Tubing Heads

Lock screws, if installed in tubing heads, shall have adequate number, size, and strength to hold a load equivalent to the working pressure of the spool acting on the full area of the largest tubing-hanger primary seal.

9.2.3.3 Penetrations

If penetrations are made in flanged connectors as specified in this specification, it shall be the responsibility of the manufacturer to ensure that the penetrations do not cause the flange stresses to exceed the design criteria.

9.2.3.4 Trapped Pressure

A means shall be provided in the wellhead installation such that any pressure behind a lock screw, alignment pin, and retainer screw can be vented prior to release.

9.2.4 Materials

Material requirements for pressure boundary penetrations shall be as specified by the manufacturer and shall be compatible with the body material. Pressure boundary penetrations used in material classes DD, EE, FF, and HH equipment shall meet the requirements of NACE MR0175/ISO 15156.

9.2.5 Marking

NOTE There are no marking requirements.

9.2.6 Storing and Shipping

Storing and shipping shall be in accordance with Section 13.

9.2.7 Testing

NOTE Assembled equipment is pressure-tested with all pressure boundary penetrations installed according to 11.2.

9.2.8 Quality Requirements

The quality control requirements for pressure boundary penetrations shall be controlled in accordance with the manufacturer's written specifications. The material properties shall conform to the requirements of 6.1 and 6.2.

9.3 Test, Gauge, Vent, and Injection Connector Ports

9.3.1 Sealing

All test, vent, injection, and gauge connectors shall provide a leak-tight seal at the hydrostatic test pressure of the equipment in which they are installed.

9.3.2 Vent and Injection Connector Ports

Vent and injection ports shall meet the requirements of the manufacturer's specifications.

9.3.3 Test and Gauge Connector Ports

9.3.3.1 69.0 MPa (10,000 psi) and Below

Test and gauge connector ports for 69.0 MPa (10,000 psi) working pressure and below shall meet one of the following:

- conform to the requirement of 14.3 and shall not be less than $\frac{1}{2}$ in. nominal size;
- conform to the requirements of 9.3.3.2.

9.3.3.2 103.5 MPa and 138.0 MPa (15,000 psi and 20,000 psi)

9.3.3.2.1 General

Test and gauge connector ports for use on 103.5 MPa and 138.0 MPa (15,000 psi and 20,000 psi) equipment shall satisfy the requirements of 9.3.3.2.

9.3.3.2.2 Design

Connectors shall conform to the dimensions in accordance with Figure 5.

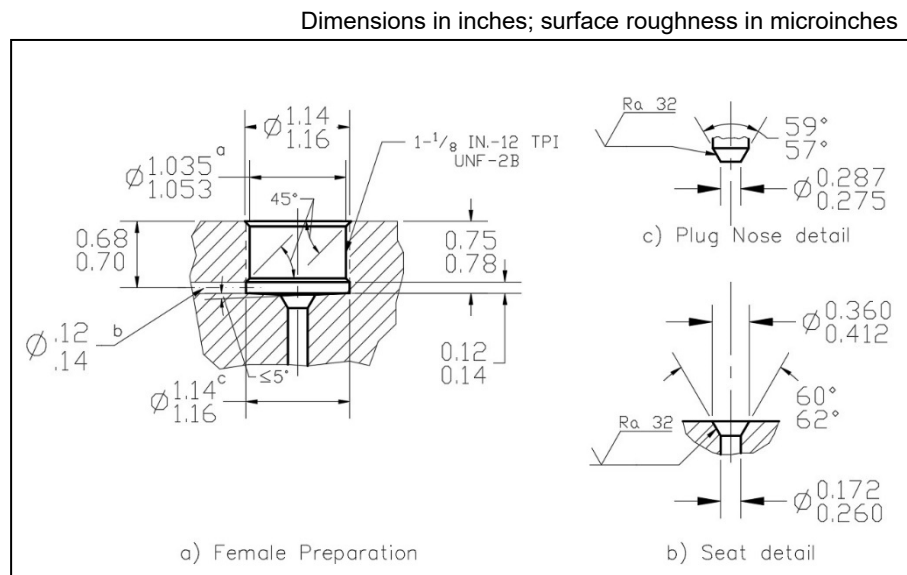
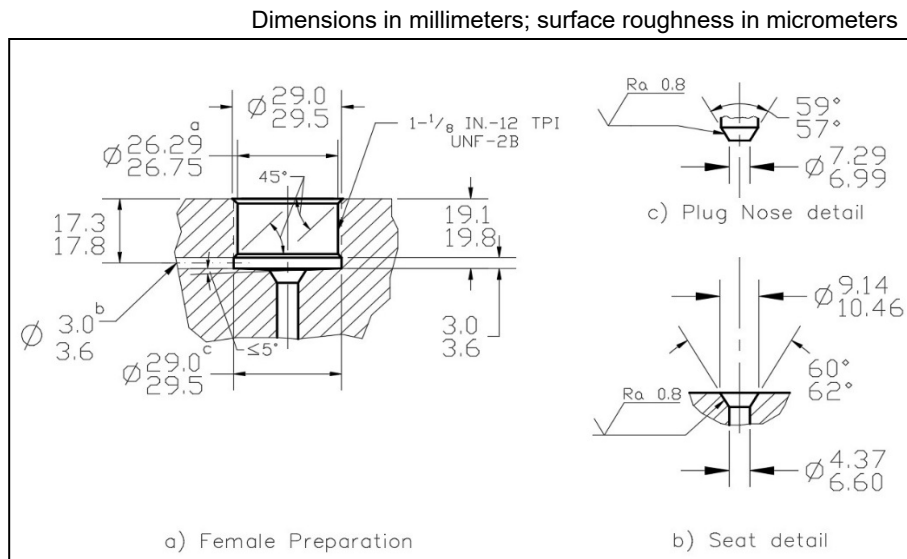

Key

- a Minor diameter of 1¹/₈-12 UNF-2B thread.
- b Drill for vent optional.
- c 15.5 mm (0.61 in.) minimum thread length or undercut to thread relief as option.

Figure 5—Test and Gauge Connector Ports for 103.5 MPa and 138.0 MPa (15,000 psi and 20,000 psi) Rated Working Pressure

All parallel threads shall be in accordance with ASME B1.1. Male threads shall be Class 2A; female threads shall be Class 2B.

Parts attached to connectors shall conform to the design methods of 5.1.1 or 5.1.3.

9.3.3.2.3 Materials

For 103.5 MPa or 138.0 MPa (15,000 psi or 20,000 psi) rated working pressure applications, the materials shall be 78 HRBW minimum. For material classes DD, EE, FF, and HH, the material shall also conform to NACE MR0175/ISO 15156.

Portions of fittings exposed directly to sour environment shall meet NACE MR0175/ISO 15156.

For material class HH, retained fluid-wetted surfaces up to and including the seal area of test ports shall be manufactured with CRA materials.

9.3.3.2.4 Testing

This specification does not require equipment furnished under 9.3 to be pressure-tested; however, if hydrostatically tested in assembled equipment, the equipment shall be designed for the hydrostatic shell test pressure.

9.3.3.2.5 Marking

NOTE There are no requirements for marking test and gauge connector ports.

9.3.3.2.6 Storage and Shipping

Connector ports shall be stored and shipped in accordance with Section 13.

10 Quality Control

10.1 Application

Equipment manufactured to this specification shall meet the quality control and record requirements of Section 10.

Equipment shall be manufactured under the manufacturer's quality management system which shall conform to an internationally recognized standard such as API Q1 or ISO 9001.

The manufacturer shall ensure control over the manufacturing processes that are outsourced.

The manufacturer shall maintain:

- a) Documented procedure for the controls used for outsourced processes;
- b) Records that provide evidence of conformity of outsourced processes to the requirements of this specification, and
- c) When applicable, records of validation for outsourced welding, heat treatment, nondestructive testing, coating and plating.

10.2 Measuring and Testing Equipment

10.2.1 General

Equipment used to inspect, test, or examine material or other equipment shall be identified, controlled, calibrated, and adjusted at specified intervals in accordance with documented manufacturer instructions, and consistent with nationally or internationally recognized standards specified by the manufacturer, to maintain the accuracy required by this specification.

10.2.2 Pressure-measuring Devices

10.2.2.1 Type and Accuracy

Test pressure-measuring devices shall be accurate to at least $\pm 2\%$ of full-scale range. If pressure gauges are used in lieu of pressure transducers, they shall be selected such that the test pressure is indicated within 20 % and 80 % of the full-scale value.

NOTE Pressure recording devices (see 15.2.1) are outside the scope of 10.2.2 unless used for both measurement and recording.

10.2.2.2 Calibration Procedure

Pressure-measuring devices shall be periodically calibrated with a master pressure-measuring device or a dead-weight tester to at least three equidistant points of full scale (excluding zero and full scale as required points of calibration).

10.2.2.3 Calibration Intervals

Calibration intervals shall be established based on repeatability and degree of usage. Calibration intervals may be lengthened and shall be shortened based on recorded calibration history.

Calibration intervals shall be a maximum of 3 months until recorded calibration history can be established by the manufacturer. Extension of intervals shall be limited to 3-month increases, with a maximum calibration interval to not exceed 1 year.

The calibration interval shall start either on the date of calibration or on the date of first use after calibration.

If the manufacturer chooses to start the calibration interval on the date of first use after calibration, the following shall apply:

- the date of first use shall be recorded, and
- the time between the calibration date and date of first use shall not exceed 3 months

10.3 Personnel Qualifications

10.3.1 Nondestructive Examination Personnel

Personnel performing NDE shall be qualified in accordance with the manufacturer's documented training program that is based on the requirements specified in the following:

- ISO 9712, or
- ASNT SNT-TC-1A, or
- a national or international standard that is equivalent to ISO 9712 or ASNT SNT-TC-1A.

10.3.2 Visual Examination Personnel

Personnel performing visual inspection for acceptance shall take and pass an annual vision examination in accordance with the manufacturer's documented procedures that meet the applicable requirements of the following:

- ISO 9712, or
- ASNT SNT SNT-TC-1A, or
- a national or international standard that is equivalent to ISO 9712 or ASNT SNT-TC-1A.

10.3.3 Welding Inspectors

Personnel performing visual inspections of welding operations and completed welds shall be qualified and certified as follows:

- AWS QC1 or equivalent certified welding inspector, or
- AWS QC1 or equivalent senior certified welding inspector, or
- AWS QC1 or equivalent certified associate welding inspector, or
- welding inspector certified by the manufacturer's documented training program.

10.3.4 Other Personnel

All other personnel performing measurements, inspections, or tests for acceptance shall be qualified in accordance with the manufacturer's documented procedures and requirements.

10.4 Requirements

10.4.1 General

10.4.1.1 Materials

Qualification requirements shall be as provided in Section 6 for mandrel tubing hangers and casing hangers; bodies, bonnets, end and outlet connectors; ring gaskets; bullplugs and valve-removal plugs; back-pressure valves; pressure boundary penetrations; clamp hub end connectors; and QTCs.

10.4.1.2 Procedures

All quality control work shall be controlled by the manufacturer's documented procedures, which include appropriate methodology and quantitative or qualitative acceptance criteria.

NDE procedures shall be supported with a documented qualification record as required by the specified normative reference standard (such as API 20D or other applicable standard) to demonstrate the procedure effectiveness. All NDE procedures shall be approved by a level III examiner qualified in accordance with ASNT SNT-TC-1A or ISO 9712.

10.4.1.3 Acceptance Status

The acceptance status of all equipment, parts, and materials shall be indicated either on the equipment, parts, or materials or in records traceable to the equipment, parts, or materials.

10.4.1.4 Material Classes DD, EE, FF, and HH

Each pressure-containing or pressure-controlling part for use in material classes DD, EE, FF, and HH shall be hardness tested individually to confirm that the NACE MR0175/ISO 15156 hardness values have been satisfied (except for ring gaskets, which may be sampled in accordance with 10.4.5.5). If the other requirements of 10.4.1 satisfy this requirement, additional testing or examination is not required.

10.4.2 Bodies, Bonnets, End and Outlet Connectors, and Clamp Hub End Connectors

10.4.2.1 Castings

Production castings shall meet the requirements of API 20A and this specification. The API 20A CSL shall be in accordance with Table 19.

Table 19—Casting Specification Level Cross-reference to PSL

API 6A	API 20A
PSL 1	CSL 2
PSL 2	CSL 3
PSL 3	CSL 3
PSL 4	NA

10.4.2.2 Tensile Testing

For PSL 1, PSL 2, PSL 3, and PSL 4, tensile testing shall be in accordance with 6.3.2.2.

10.4.2.3 Impact Testing

For PSL 1, PSL 2, PSL 3, and PSL 4, impact testing shall be in accordance with 6.3.2.3.

10.4.2.4 Hardness Testing**10.4.2.4.1 Application**

The requirements of 10.4.1.4 shall apply.

Additionally, the requirements of 10.4.2.4 shall apply to PSL 1, PSL 2, PSL 3, and PSL 4, except as noted in the following.

- c) For PSL 1, bodies, bonnets, end and outlet connectors, stems, loose connectors, and clamp hub end connectors with 13.8 MPa, 20.7 MPa, and 34.5 MPa (2000 psi, 3000 psi, and 5000 psi) working pressure, sampling shall be in accordance with ISO 2859-1:1999, level II, 4.0 AQL (acceptance quality limit), with the following exception. For DD, EE, FF, and HH material class equipment, each pressure-containing or pressure-controlling part shall be individually hardness tested.
- d) For PSL 2, PSL 3, and PSL 4, all parts shall be hardness tested.

NOTE 1 This additional requirement does not apply to PSL 1.

- e) For PSL 3 and PSL 4, additionally one hardness test shall be performed on each finished part (body, bonnet, and end connectors) with additional tests on each end connector face. When it is not possible to hardness test the end connector face, the hardness test shall be performed on the nearest accessible surface.

NOTE 2 Where multiple end connector faces are located on the same finished machined surface, a single hardness punch may be used to represent all end connectors.

NOTE 3 This additional requirement does not apply to PSL 1 and PSL 2.

If bodies, end and outlet connectors, and clamp hub ends have different material designations, each part shall be tested.

10.4.2.4.2 Test Method

Hardness testing shall be performed in accordance with procedures specified in ISO 6506, parts 1 through 4 or ASTM E10 (Brinell), or ISO 6508, parts 1 through 3 or ASTM E18 (Rockwell).

NOTE 1 Hardness testers meeting the requirements of ASTM E110 and ISO 6506 (all parts) or ASTM E10, or ISO 6508 (all parts) or ASTM E18, as applicable, may be used for hardness testing.

ISO 18265 or ASTM E140 shall be used for the conversion of hardness readings for materials within the scope of their application.

NOTE 2 Other correlations may be established for individual materials that are outside the scope of ISO 18265 or ASTM E140.

When a conversion other than ASTM E140 conversion is used, the conversion method shall be documented and shall be based on documented test results.

Tests shall be performed at a location determined by the manufacturer's specifications and following the last heat-treatment cycle (including all stress-relieving heat-treatment cycles) and all exterior machining at the test location.

10.4.2.4.3 Acceptance Criteria

Parts manufactured from nonstandard, high-strength materials shall meet the minimum hardness requirements of the manufacturer's written specification.

Parts manufactured from standard materials shall meet the requirements of Table 20.

Table 20—Minimum Hardness Values

Material Designation	Minimum Brinell Hardness
36K	HBW 140
45K	HBW 140
60K	HBW 174
75K	HBW 197

For parts manufactured from a standard material that does not conform to the specified minimum hardness value of Table 20, the material shall be acceptable if the measured hardness exceeds the minimum acceptable Brinell hardness value calculated using Equation 3, with results of tensile tests performed per 6.3.2.2 for the material of the part in question:

$$H_{\text{BWc, min.}} = \frac{R_{\text{m, min.}}}{\bar{R}_{\text{m, QTC}}} (\bar{H}_{\text{BW, QTC}}) \quad (3)$$

where

$H_{\text{BWc, min.}}$ is the minimum acceptable Brinell hardness according to the HBW method for the part after the final heat-treatment cycle (including stress-relieving cycles);

$R_{\text{m, min.}}$ is the minimum acceptable ultimate tensile strength for the applicable material designation;

$\bar{R}_{\text{m, QTC}}$ is the average ultimate tensile strength determined from the QTC tensile tests;

$\bar{H}_{\text{BW, QTC}}$ is the average of the Brinell hardness values according to the HBW method observed among all tests performed on the QTC.

10.4.2.5 Dimensional Inspection

10.4.2.5.1 Application

Dimensional inspection shall be performed on parts. The manufacturer shall specify critical dimensions.

All end and outlet connector threads covered by 14.3 of this specification on all parts shall be inspected. Critical dimensions on all parts shall be verified.

For PSL 1 and PSL 2, other features shall be checked on sample parts in accordance with ISO 2859-1:1999, level II, 1.5 AQL.

For PSL 3 and PSL 4, sampling shall not be allowed; all parts shall be dimensionally inspected.

10.4.2.5.2 Inspection Method and Acceptance Criteria

If a thread gauge is used for inspection, it shall conform to the requirements for working gauges as stipulated in API 5B. Threads shall be inspected for standoff at hand-tight assembly.

NOTE 1 For threads manufactured in accordance with this specification, use gauging practices as illustrated in Table D.29/Table E.29 and Table D.30/Table E.30. For threads manufactured in accordance with API 5B, use gauging practices as specified in API 5B.

NOTE 2 Threaded end and outlet connectors may be inspected for standoff at hand-tight assembly by use of the gauges and gauging practices illustrated in Table D.29/Table E.29 and Table D.30/Table E.30, or according to API 5B.

The end and outlet connector threads shall be in accordance with Table D.29/Table E.29 and Table D.30/Table E.30, API 5B or ASME B1.20.1, as applicable.

Acceptance criteria for critical dimensions shall be as required by the manufacturer's written specification.

10.4.2.6 Visual Examination

10.4.2.6.1 Application

NOTE Visual examination requirements do not apply to PSL 3 and PSL 4 except for welds (see 10.4.2.13).

For PSL 1 and PSL 2, each part shall be visually examined.

10.4.2.6.2 Test Method and Acceptance Criteria

For PSL 1 and PSL 2, visual examinations of castings shall be performed in accordance with procedures specified in API 20A. Visual examination of wrought material and weld preparations shall be performed in accordance with the manufacturer's written specifications.

For PSL 1 and PSL 2, the acceptance criteria shall be as follows:

- for castings, in accordance with API 20A;
- for wrought material and weld preparations, in accordance with the manufacturer's written specifications.

10.4.2.6.3 Supplemental Requirement

For PSL 2, wetted and sealing surfaces shall be examined by surface NDE methods described in 10.4.2.10 for ferromagnetic materials and 10.4.2.11 for nonferromagnetic materials, as applicable.

NOTE This supplemental visual examination requirement does not apply to PSL 1.

10.4.2.7 Chemical Analysis

For PSL 2, PSL 3, and PSL 4, chemical analysis shall be performed on a heat basis (or a remelt-ingot basis for remelt-grade materials) in accordance with a nationally or internationally recognized standard.

The chemical composition shall meet the requirements of 6.3.5 and the manufacturer's written specification.

NOTE Chemical analysis requirements do not apply to PSL 1.

10.4.2.8 Traceability

For PSL 2, PSL 3, and PSL 4, the following requirements shall apply.

- Job-lot traceability shall be required.
- Identification shall be maintained on materials and parts to facilitate traceability, as required by documented manufacturer requirements.
- Manufacturer-documented traceability requirements shall include provisions for maintenance or replacement of identification marks and identification control records.

For PSL 3 and PSL 4 only, in addition, manufactured parts shall be traceable to a specific heat and heat-treat lot.

NOTE The traceability requirements do not apply to PSL 1.

10.4.2.9 Serialization

For PSL 3 and PSL 4, the following requirements shall apply.

Each individual part and/or piece of equipment shall be assigned and marked with a unique code to maintain traceability and associated records.

NOTE The serialization requirements do not apply to PSL 1 and PSL 2.

10.4.2.10 Surface NDE—Ferromagnetic Materials

10.4.2.10.1 Castings

For castings, the following shall apply.

For PSL 1, all accessible wetted surfaces and all accessible sealing surfaces for one casting from each heat lot shall be examined by liquid penetrant or magnetic particle methods after final heat-treatment and final machining operations. If the casting fails to meet the surface NDE acceptance criteria (see 10.4.2.10.3), surface NDE shall be performed on all castings from that heat on all accessible wetted surfaces and all accessible sealing surfaces.

NOTE 1 As noted in Table 5, PSL 1 does not apply to bodies, bonnets, end and outlet connectors, and clamp hub end connectors with 69.0 MPa, 103.5 MPa, and 138.0 MPa (10,000 psi, 15,000 psi, and 20,000 psi) working pressures.

For PSL 2 and PSL 3, all accessible wetted surfaces and all accessible sealing surfaces of each finished part shall be examined by liquid penetrant or magnetic particle methods after final heat-treatment and final machining operations.

For PSL 3, additionally all accessible surfaces of each finished part shall be inspected. Surface NDE shall be performed on all surfaces prepared for "weld metal overlay."

NOTE 2 These additional requirements do not apply to PSL 1 and PSL 2.

10.4.2.10.2 Wrought Material

For wrought material, the following shall apply.

For PSL 2, PSL 3, and PSL 4, all accessible wetted surfaces and all accessible sealing surfaces of each finished part shall be examined by liquid penetrant or magnetic particle methods after final heat-treatment and final machining operations.

NOTE 1 This requirement does not apply to PSL 1.

For PSL 3 and PSL 4, additionally all accessible surfaces of each finished part shall be inspected. Surface NDE shall be performed on all surfaces prepared for “weld metal overlay.”

NOTE 2 These additional requirements do not apply to PSL 1 and PSL 2.

10.4.2.10.3 Test Method and Acceptance Criteria

For PSL 1 and PSL 2, all ferromagnetic materials shall be examined in accordance with procedures specified in ASTM E165 (penetrant test [PT]) or ASTM E709 (magnetic particle test [MT]).

Prods shall not be permitted on wetted surfaces or sealing surfaces.

If any indications are believed to be nonrelevant on the basis that they are not associated with a surface rupture (i.e. magnetic permeability variations, nonmetallic stringers), they shall be examined by liquid penetrant surface NDE methods, or removed and reinspected, to confirm their nonrelevancy.

For PSL 3 and PSL 4, all ferromagnetic materials shall be examined in accordance with procedures specified in ASTM E165 (PT) or only the wet fluorescent method in ASTM E709 (MT) for all magnetic particle examinations.

NOTE The ASTM E709 (MT) wet fluorescent method limitation does not apply to PSL 1 and PSL 2.

The following acceptance criteria shall apply for the ASTM E709 (MT) examination:

- no relevant indication with a major dimension equal to or greater than 5 mm (³/₁₆ in.);
- no more than ten relevant indications in any continuous 40 cm² (6 in.²) area;
- no four (or more) relevant rounded indications in a line separated by less than 1.6 mm (¹/₁₆ in.) (edge-to-edge);
- no relevant indications in pressure-contact sealing surfaces.

The acceptance criteria in 10.4.2.11.3 shall apply for the ASTM E165 (PT) examination.

10.4.2.11 Surface NDE—Nonferromagnetic Materials

10.4.2.11.1 Castings

For castings, the following shall apply.

NOTE 1 As noted in Table 5, PSL 1 does not apply to bodies, bonnets, end and outlet connectors and clamp hub end connectors with 69.0 MPa, 103.5 MPa, and 138.0 MPa (10,000 psi, 15,000 psi, and 20,000 psi) working pressures.

For PSL 1, all accessible wetted surfaces and all accessible sealing surfaces for one casting from each heat lot shall be examined by the liquid penetrant method after final heat-treatment and final machining operations. If the casting fails to meet the surface NDE acceptance criteria (see 10.4.2.11.3), surface NDE

shall be performed on all castings from that heat on all accessible wetted surfaces and all accessible sealing surfaces.

For PSL 2 and PSL 3, all accessible wetted surfaces and all accessible sealing surfaces of each finished part shall be liquid penetrant inspected after final heat-treatment and final machining operations.

For PSL 3 additionally, all accessible surfaces of each finished part shall be inspected. Surface NDE shall be performed on all surfaces prepared for “weld metal overlay.”

NOTE 2 This additional requirement does not apply to PSL 1 and PSL 2.

10.4.2.11.2 Wrought Material

For wrought material, the following shall apply.

For PSL 2, PSL 3, and PSL 4, all accessible wetted surfaces and all accessible sealing surfaces of each finished part shall be examined by the liquid penetrant method after final heat-treatment and final machining operations.

NOTE 1 This requirement does not apply to PSL 1.

For PSL 3 and PSL 4, additionally all accessible surfaces of each finished part shall be inspected. Surface NDE shall be performed on all surfaces prepared for “weld metal overlay.”

NOTE 2 These additional requirements do not apply to PSL 1 and PSL 2.

10.4.2.11.3 Test Method and Acceptance Criteria

All nonferromagnetic materials shall be examined in accordance with procedures specified in ASTM E165.

The acceptance criteria shall be as follows:

- no relevant linear indications allowed;
- no more than ten relevant rounded indications in any continuous 40 cm² (6 in.²) area;
- no relevant rounded indication with a major dimension equal to or greater than 5 mm (³/₁₆ in.);
- no four (or more) relevant rounded indications in a line separated by less than 1.6 mm (¹/₁₆ in.) (edge-to-edge);
- no relevant indication in pressure-contact sealing surfaces.

10.4.2.12 Volumetric NDE

10.4.2.12.1 Application

For PSL 2 (castings), for bodies, bonnets, and loose connectors with rated working pressure of 69.0 MPa (10,000 psi) or higher, the entire volume of one casting from each heat lot shall be subjected to volumetric NDE, by ultrasonic (UT) or radiographic (RT) examination. If the sample casting fails to meet the volumetric NDE acceptance criteria, volumetric NDE shall be performed on all castings from that heat.

NOTE 1 The sampling requirements for PSL 2 do not apply to PSL 1, PSL 3, and PSL 4.

For PSL 3 and PSL 4 (castings and wrought material) as far as practical, the entire volume of each part shall be volumetrically inspected (radiography or ultrasonic) after heat-treatment for mechanical properties and prior to machining operations that limit effective interpretation of the results of the examination. For quench-and-tempered products, the volumetric inspection shall be performed after heat-treatment for mechanical properties exclusive of stress-relief treatments or re-tempering to reduce hardness.

NOTE 2 The sampling requirements for PSL 3/PSL 4 do not apply to PSL 1 and PSL 2.

10.4.2.12.2 Ultrasonic Examination Test Method

For PSL 2 and PSL 3 castings, ultrasonic examinations of castings shall be performed in accordance with the flat-bottom hole procedure specified in ASTM A609 (except that the immersion method may be used) and ASTM E428.

For PSL 3 and PSL 4 wrought material, ultrasonic examination shall be performed in accordance with the flat-bottom hole procedures specified in ASTM A388/388M (except that the immersion method may be used) and ASTM E428.

- Calibration: The distance amplitude curve (DAC) shall be based on a maximum 1.6 mm ($1/16$ in.) flat-bottom hole (straight-beam technique) for metal thicknesses through 38 mm ($1\frac{1}{2}$ in.), on a maximum 3.2 mm ($1/8$ in.) flat-bottom hole for metal thicknesses from 38 mm ($1\frac{1}{2}$ in.) through 150 mm (6 in.), and on a maximum 6.4 mm ($1/4$ in.) flat-bottom hole for metal thicknesses exceeding 150 mm (6 in.).

NOTE Ultrasonic examination does not apply to PSL 1.

10.4.2.12.3 Ultrasonic Examination Acceptance Criteria

For PSL 2, PSL 3, and PSL 4, the following shall apply:

- no single indication exceeding reference DAC;
- no multiple indications exceeding 50 % of reference DAC; multiple indications are defined as two or more indications (each exceeding 50 % of the reference DAC) within 13 mm ($1/2$ in.) of each other in any direction.

For PSL 4 only, in addition, no continuous cluster of indications on the same plane, regardless of amplitude, shall be found over an area twice the diameter of the search unit.

NOTE This additional requirement does not apply to PSL 2 or PSL 3.

10.4.2.12.4 Radiographic Examination Test Method

For PSL 2 and PSL 3 castings, and for PSL 3 and PSL 4 wrought material, radiographic examination shall be performed in accordance with methods specified in ASME BPVC, Section V, Article 2 (or equivalent) using 2T Essential Hole for plaque type IQI or Equivalent Essential wire for wire type IQI. Both X-ray and gamma-ray sources shall be acceptable within the inherent thickness range limitation of each.

NOTE 1 Real time imaging and recording/enhancement methods may be used provided the designated hole image quality indicator or essential wire is displayed as required by ASME BPVC, Section V, Article 2.

NOTE 2 Radiographic examination does not apply to PSL 1.

10.4.2.12.5 Radiographic Examination Acceptance Criteria—Wrought Materials

For PSL 3, the following acceptance criteria shall apply:

- no cracks, laps, or bursts;
- no elongated indication with a length greater than that given in Table 21;

Table 21—Maximum Length of Elongated Indication

Thickness, T		Inclusion Length	
mm	in.	mm	in.
< 19.0	< 0.75	6.4	0.25
19.0 to 57.0	0.75 to 2.25	$0.33T$	$0.33T$
> 57.0	> 2.25	19.0	0.75

- no group of indications in a line that have an aggregate length greater than T in a length of $12T$.

NOTE 1 The PSL 3 requirements do not apply to PSL 4.

For PSL 4 only, the following acceptance criteria shall apply:

- no cracks, laps, or bursts;
- no more than two indications separated by less than 13 mm ($1/2$ in.);
- no elongated indication exceeding 6.4 mm ($1/4$ in.).

NOTE 2 The PSL 4 requirements do not apply to PSL 3.

10.4.2.12.6 Radiographic Examination Acceptance Criteria—Cast Parts

For PSL 2 and PSL 3, the following shall apply:

- ASTM E186;
- ASTM E280;
- ASTM E446;
- maximum defect classification as follows:

Type Defect	Maximum Defect Class
A	2
B	2
C	2 (all types)
D	None acceptable
E	None acceptable
F	None acceptable
G	None acceptable

10.4.2.13 Weld NDE—General

For PSL 1, PSL 2, PSL 3, and PSL 4, the following shall apply.

Completed welds [a minimum of 12.7 mm (1/2 in.) of surrounding base metal and the entire accessible weld] shall be examined in accordance with the methods and acceptance criteria of Table 22.

Table 22—Requirements for Welding Bodies, Bonnets, and End and Outlet Connectors

Weld Type	Stages ^{a,b}	Reference			
		PSL 1	PSL 2	PSL 3	PSL 4
Pressure-containing	Preparation - Visual	—	—	10.4.2.6	10.4.2.6
	Completion - Visual	—	10.4.2.14	10.4.2.14	10.4.2.14
	Completion - Surface NDE	—	10.4.2.15	10.4.2.15	10.4.2.15
	Completion - Volumetric NDE	—	10.4.2.16	10.4.2.16	10.4.2.16
	Completion - Hardness test	—	—	10.4.2.17	10.4.2.17
Nonpressure-containing (including repairs)	Preparation - Visual	—	—	10.4.2.6	10.4.2.6
	Completion - Visual	—	10.4.2.14	10.4.2.14	10.4.2.14
	Completion - Hardness test	—	—	10.4.2.17	10.4.2.17
Pressure-containing repairs	Preparation - Surface NDE	—	10.4.2.15	10.4.2.15	10.4.2.15
	Completion - Visual	—	10.4.2.14	10.4.2.14	10.4.2.14
	Completion - Surface NDE	—	10.4.2.15	10.4.2.15	10.4.2.15
	Completion - Volumetric NDE	—	10.4.2.16	10.4.2.16	10.4.2.16
	Completion - Hardness test	—	—	10.4.2.17	10.4.2.17
Partial weld metal overlay	Preparation - Surface NDE	—	—	10.4.2.10	10.4.2.10
	Completion - Surface NDE	—	10.4.2.15	10.4.2.15	10.4.2.15
	Completion - Volumetric NDE	—	—	10.4.2.18	10.4.2.18
Full weld metal overlay	Preparation - Visual	10.4.2.6	10.4.2.6	—	—
	Preparation - Surface NDE	—	—	10.4.2.10	10.4.2.10
	Completion - Visual	10.4.2.14	10.4.2.14	10.4.2.14	10.4.2.14
	Completion - Surface NDE	—	10.4.2.15	10.4.2.15	10.4.2.15
	Completion - Volumetric NDE	—	—	10.4.2.18	10.4.2.18
FOOTNOTES					
^a "Preparation" refers to surface preparation, joint preparation, fit-up, and preheat. ^b "Completion" refers to after all welding, post-weld heat-treat, and machining, except for volumetric NDE that shall be done prior to machining that would limit effective interpretation of results.					

The manufacturer's written specification for corrosion-resistant weld overlay shall include a technique for measuring the specified overlay thickness. The production acceptance criteria measurements shall account for the depth of penetration to the approximate weld interface when the weld qualification was performed using the fusion face.

10.4.2.14 Weld Examination—Visual

The visual weld examination requirements of 10.4.2.14 shall apply to PSL 1, PSL 2, PSL 3, and PSL 4 as specified in Table 22.

100 % of all welds shall be visually examined after post-weld heat-treatment and machining operations.

Examinations shall include a minimum of 13 mm (1/2 in.) of adjacent base metal on both sides of the weld.

The acceptance criteria shall be as follows.

- All pressure-containing welds shall have complete joint penetration.
- Undercut shall not reduce the thickness in the area (considering both sides) to below the minimum thickness.
- Surface porosity and exposed slag are not permitted on or within 3 mm ($1/8$ in.) of sealing surfaces.

10.4.2.15 Weld NDE—Surface

10.4.2.15.1 Application

The surface weld examination requirements of 10.4.2.15 shall apply to PSL 2, PSL 3, and PSL 4.

For PSL 3 and PSL 4, magnetic particle examination shall be performed only by the wet fluorescent method.

NOTE The surface weld examination requirements do not apply to PSL 1.

100% of all pressure-containing fabrication welds and weld overlay shall be examined by either magnetic particle (in the case of ferromagnetic materials) or liquid penetrant (in the case of ferromagnetic or nonferromagnetic materials) methods after all welding, post-weld heat-treatment, and machining operations.

10.4.2.15.2 Test Method/Acceptance—Magnetic Particle Examination

Examinations shall include a minimum of 13 mm ($1/2$ in.) of adjacent base metal on both sides of the weld.

Magnetic particle examination shall be performed as described in 10.4.2.10.3 with additional acceptance criteria as follows:

- no relevant linear indication;
- no rounded indication greater than 3 mm ($1/8$ in.) for welds whose depth is 16 mm ($5/8$ in.) or less, or 5 mm ($3/16$ in.) for welds whose depth is greater than 16 mm ($5/8$ in.).

10.4.2.15.3 Test Method/Acceptance—Liquid Penetrant Examination

Liquid penetrant examination shall be performed as described in 10.4.2.11.3 with additional acceptance criterion of no rounded indications greater than 3 mm ($1/8$ in.) for welds whose depth is 16 mm ($5/8$ in.) or less, or 5 mm ($3/16$ in.) for welds whose depth is greater than 16 mm ($5/8$ in.).

10.4.2.16 Weld NDE—Volumetric

10.4.2.16.1 Application

The volumetric weld examination requirements of 10.4.2.16 shall apply to PSL 2, PSL 3, and PSL 4.

NOTE The volumetric weld examination requirements do not apply to PSL 1.

10.4.2.16.2 Test Method—Radiographic Examination

Radiographic examinations shall be performed in accordance with the procedures specified in ASME *BPVC* Section V, Article 2 (or equivalent) using 2T Essential Hole for plaque type IQI or Equivalent Essential wire for wire type IQI.

Both X-ray and gamma-ray sources are acceptable within the inherent thickness range limitation of each. Real time imaging and recording/enhancement methods may be used provided the designated hole image quality indicator or essential wire is displayed as required by ASME *BPVC*, Section V, Article 2.

10.4.2.16.3 Acceptance Criteria—Radiographic Examination

The radiographic examination acceptance criteria shall be as follows:

- no type of crack, zone of incomplete fusion, or incomplete penetration;

- no elongated discontinuity that has a length greater than that given in Table 23;

Table 23—Maximum Length of RT Discontinuities

Weld Thickness, <i>T</i>		Discontinuity Length	
mm	in.	mm	in.
≤ 19.0	≤ 0.75	6.4	0.25
> 19.0 to ≤ 57.0	> 0.75 to ≤ 2.25	0.33 <i>T</i>	0.33 <i>T</i>
> 57.0	> 2.25	19.0	0.75

- no group of discontinuities in a line having an aggregated length greater than the weld thickness, *T*, in any total weld length of 12*T*, except where the distance between successive discontinuities exceeds six times the length of the longest discontinuity;
- no rounded indication in excess of that specified in ASME *BPVC*, Section VIII, Division 1, Appendix 4.

10.4.2.16.4 Test Method—Ultrasonic Examination

Ultrasonic examinations shall be performed in accordance with procedures specified in ASME *BPVC*, Section V, Subsection A, Article 4 (or equivalent).

10.4.2.16.5 Acceptance Criteria—Ultrasonic Examination

Discontinuities that produce a response greater than 20 % of the reference level shall be investigated to the extent necessary to determine the shape, identity, and location and evaluate them in terms of the acceptance criteria below:

- no linear indication interpreted as cracks, incomplete joint penetration, or incomplete fusion;
- other indications with amplitudes exceeding the reference level whose length exceeds those given in Table 24 are unacceptable.

10.4.2.16.6 Repair Welds

For PSL 2, PSL 3, and PSL 4, 100 % of all pressure-containing welds shall be examined by either radiography or ultrasonic methods after all welding, post-weld heat-treatment, and machining operations but prior to machining operations that limit effective interpretation of the results of the examination. All repair welds where the repair is greater than 25 % of the original wall thickness or 25 mm (1 in.), whichever is less, shall be examined by either radiography or ultrasonic methods after all welding and post-weld heat-treatment. Examinations shall include at least 13 mm (1/2 in.) of adjacent base metal on all sides of the weld.

NOTE The following additional repair weld volumetric weld NDE requirement does not apply to PSL 2:

For PSL 3 and PSL 4 only, all repair welds, if the repair exceeds 20 % of the original wall thickness or 25 mm (1 in.), whichever is the smaller, or if the extent of the cavity exceeds approximately 65 cm² (10 in.²), shall be examined by either radiography or ultrasonic methods after all welding and post-weld heat-treatment.

Table 24—Maximum Length of UT Discontinuities

Weld Thickness, <i>T</i> ^a		Discontinuity Length	
mm	in.	mm	in.
≤ 19.0	≤ 0.75	6.4	0.25
> 19.0 to ≤ 57.0	> 0.75 to ≤ 2.25	0.33 <i>T</i>	0.33 <i>T</i>
> 57.0	> 2.25	19.0	0.75
FOOTNOTE			
^a <i>T</i> is the thickness of the weld being examined. If a weld joins two members having different thicknesses at the weld, <i>T</i> is the thinner of the two thicknesses.			

10.4.2.17 Weld NDE—Hardness

The hardness weld NDE requirements of 10.4.2.17 shall apply to PSL 3 and PSL 4.

NOTE The hardness weld NDE requirements do not apply to PSL 1 and PSL 2.

Except for overlays, 100 % of all accessible welds (including repairs) shall be hardness tested.

Hardness testing shall be performed in accordance with ISO 6506 (all parts) or ISO 6508 (all parts), or ASTM E10 or ASTM E18.

When the WPS requires PWHT, hardness testing shall be performed after all heat treatment on the weld metal and the base metal within 13 mm (0.5 in.) from the weld to conform to 10.4.2.4. When the WPS does not require PWHT, the weld metal at a minimum shall be hardness tested to conform to 10.4.2.4.

Hardness values shall meet the base material requirements of 10.4.2.4.

The hardness recorded in the PQR shall be the basis for acceptance if the weld is not accessible for hardness testing.

10.4.2.18 Weld Overlay Volumetric Inspection

10.4.2.18.1 Application

The weld overlay volumetric inspection requirements of 10.4.2.18 shall apply to PSL 3 and PSL 4 except for ring grooves that conform to this specification.

10.4.2.18.2 Design Requirements

For PSL 3 and PSL 4 overlay welds other than ring grooves conforming to this specification, the manufacturer shall document if the overlay material is necessary to meet the design requirements of Section 5.1, and:

- If the overlay material is necessary to meet the design requirements of Section 5.1, volumetric examination shall be in accordance with 10.4.2.18.3.
- If the overlay material is not necessary to meet the design requirements of Section 5.1, a measurement of overlay thickness and testing of bond integrity shall be performed according to the manufacturer's written specifications.

NOTE 1 These requirements do not apply to PSL 1 and PSL 2.

NOTE 2 See Table 22.

10.4.2.18.3 Test Methods and Acceptance Criteria

Weld overlay shall be examined using ultrasonic examination performed in accordance with ASME BPVC, Section V, Subsection A, Article 4 technique 1 except that the immersion method may be used.

The acceptance criteria shall be as follows:

- no single indication exceeding reference DAC;
- no multiple indications exceeding 50 % of reference DAC.

NOTE "Multiple indications" is defined as two or more indications (each exceeding 50 % of the reference DAC) within 13 mm ($\frac{1}{2}$ in.) of each other in any direction.

10.4.2.19 Repair Welds

For PSL 2, PSL 3, and PSL 4, the following requirements shall apply.

- All repair welds shall be examined using the same methods and acceptance criteria as used for examining the base metal or weld metal.
- Examinations shall include 13 mm (1/2 in.) of adjacent base metal on all sides of the weld.
- Surfaces prepared for welding shall be examined prior to welding to ensure defect removal to acceptable levels. Methods and acceptance criteria shall be as in 10.4.2.15.

NOTE The repair weld requirements do not apply to PSL 1.

10.4.3 Stems

10.4.3.1 Quality Control Requirements, Methods, and Acceptance Criteria

Quality control requirements for stems shall be per Table 25 for PSL 1, PSL 2, PSL 3, and PSL 4. Where reference is made in 10.4.3 to requirements in 10.4.2, those shall be applicable to stems.

Table 25—Requirements for Stems

Parameter ^{a,b}	Reference			
	PSL 1	PSL 2	PSL 3	PSL 4
Tensile testing	10.4.2.2	10.4.2.2	10.4.2.2	10.4.2.2
Impact testing	10.4.2.3	10.4.2.3	10.4.2.3	10.4.2.3
Hardness testing	10.4.2.4	10.4.2.4	10.4.2.4	10.4.2.4
NACE MR0175/ISO 15156	10.4.1.4	10.4.1.4	10.4.1.4	10.4.1.4
Dimensional inspection	10.4.2.5	10.4.2.5	10.4.2.5	10.4.2.5
Visual examination	10.4.2.6	10.4.2.6	—	—
Chemical analysis	—	10.4.2.7	10.4.2.7	10.4.2.7
Traceability	—	10.4.2.8	10.4.2.8	10.4.2.8
Surface NDE	—	10.4.2.10/10.4.2.11	10.4.2.10/10.4.2.11	10.4.2.10/10.4.2.11
Weld NDE	No welding permitted except for weld overlays	No welding permitted except for weld overlays	No welding permitted except for weld overlays	No welding permitted except for weld overlays
Weld overlay				
General	10.4.3.3	10.4.3.3	10.4.3.3	10.4.3.3
Preparation - Visual	10.4.2.6	—	—	—
Preparation - Surface NDE	—	10.4.2.10/10.4.2.11	10.4.2.10/10.4.2.11	10.4.2.10/10.4.2.11
Completion - Visual	10.4.2.14	10.4.2.14	10.4.2.14	10.4.2.14
Completion - Surface NDE	—	10.4.2.15	10.4.2.15	10.4.2.15
Serialization	—	—	10.4.2.9	10.4.2.9
Volumetric NDE	—	—	10.4.2.12	10.4.2.12
FOOTNOTES				
^a "Preparation" refers to surface preparation, joint preparation, fit-up, and preheat.				
^b "Completion" refers to after all welding, post-weld heat-treat, and machining, except for volumetric NDE that shall be done prior to machining that would limit effective interpretation of results.				

10.4.3.2 Volumetric NDE

10.4.3.2.1 Application

The volumetric NDE requirements of 10.4.3.2 shall apply to PSL 3 and PSL 4.

NOTE The volumetric NDE requirements do not apply to PSL 1 and PSL 2.

Each stem, or bar from which stems are machined, shall be volumetrically inspected using ultrasonic or radiographic techniques. The inspection shall be conducted after final heat-treatment (exclusive of stress-relief treatments) and prior to machining operations that limit effective interpretation of the results of the examination.

10.4.3.2.2 Test Method and Acceptance Criteria

Inspection shall be performed in accordance with the methods of 10.4.2.12 for wrought materials. If ultrasonic inspection is performed, each stem (or bar from which stems are machined) shall be ultrasonically inspected from the outside diameter and ends by the straight-beam technique. Stems that cannot be examined axially using the straight-beam technique shall be examined using the angle-beam technique.

The DAC shall be based on a maximum 3.2 mm ($1/8$ in.) flat-bottom hole (straight-beam technique) and a maximum 1.6 mm ($1/16$ in.) side-drilled hole, 25 mm (1 in.) deep (angle-beam technique).

Acceptance criteria shall be in accordance with 10.4.2.12.3, 10.4.2.12.5, or 10.4.2.12.6.

NOTE The volumetric NDE requirements do not apply to PSL 1 and PSL 2.

10.4.3.3 Weld NDE—General

For PSL 1, PSL 2, PSL 3, and PSL 4, the manufacturer's written specification for corrosion-resistant weld overlay shall include a technique for measuring the specified overlay thickness.

10.4.4 Valve Bore Sealing Mechanisms and Choke Trim

10.4.4.1 Application

For PSL 1, PSL 2, PSL 3, and PSL 4, Table 26 lists the quality control requirements for valve bore sealing mechanisms and choke trim. For choke trim, only the surface NDE and serialization shall apply. Surface NDE is not required on brazed, press-fit, or shrink-fit joints. Indications that are restricted to a brazed, press-fit, or shrink-fit joint are not relevant.

10.4.4.2 Weld NDE—General

If examination is required, welding activities shall be controlled in conformance with 7.3.8 and shall be examined in accordance with the methods and acceptance criteria of Table 26.

The manufacturer's written specification for corrosion-resistant weld overlay shall include a technique for measuring the specified overlay thickness.

10.4.5 Ring Gaskets and Nonintegral Metal Seals

10.4.5.1 Application

NOTE PSLs are not applicable to ring joint gaskets and nonintegral metal seals.

10.4.5.2 Tensile Testing

For nonintegral metal seals, tensile testing shall be in accordance with 6.3.2.2 if tensile stress is a design criterion.

NOTE Tensile testing requirements do not apply to ring gaskets.

10.4.5.3 Impact Testing

For nonintegral metal seals, impact testing shall be in accordance with 6.3.2.3 if tensile stress is a design criterion.

NOTE Impact testing requirements do not apply to ring gaskets.

Table 26—Requirements for Valve Bore Sealing Mechanisms and Choke Trim

Parameter ^{a,b}	Reference			
	PSL 1	PSL 2	PSL 3	PSL 4
Tensile testing	6.3.2.2	6.3.2.2	6.3.2.2	6.3.2.2
Hardness testing	—	—	10.4.2.4	10.4.2.4
NACE MR0175/ISO 15156	10.4.1.4	10.4.1.4	10.4.1.4	10.4.1.4
Dimensional inspection	—	—	10.4.2.5	10.4.2.5
Chemical analysis	—	10.4.2.7	10.4.2.7	10.4.2.7
Traceability	—	—	10.4.2.8	10.4.2.8
Surface NDE ^c	—	—	10.4.2.10/10.4.2.11	10.4.2.10/10.4.2.11
Weld NDE				No welding permitted except for weld overlays
General	—	10.4.4.2	10.4.4.2	
Visual examination	—	10.4.2.14	10.4.2.14	
NDE surface	—	10.4.2.15	10.4.2.15	
Hardness testing	—	—	10.4.2.17	
Repair welds	—	10.4.2.19	10.4.2.19	
Weld overlay				
Preparation - Surface NDE	—	—	10.4.2.10	10.4.2.10
Completion - Surface NDE	—	10.4.2.15	10.4.2.15	10.4.2.15
Serialization ^c	—	—	10.4.2.9	10.4.2.9
FOOTNOTES				
^a "Preparation" refers to surface preparation, joint preparation, fit-up, and preheat.				
^b "Completion" refers to after all welding, post-weld heat-treat, and machining, except for volumetric NDE that shall be done prior to machining that would limit effective interpretation of results.				
^c Only the surface NDE and serialization are required for choke trim (see 10.4.4.1).				

10.4.5.4 Dimensional Inspection

Dimensional inspection shall be performed on ring gaskets and nonintegral metal seals manufactured according to this specification.

Sampling shall be in accordance with the manufacturer's documented requirements.

The manufacturer's documented procedures shall be followed.

Acceptance criteria for ring gaskets shall be in accordance with 14.2.2.1. Nonintegral metal seals shall be in accordance with the manufacturer's documented requirements.

10.4.5.5 Hardness Testing

10.4.5.5.1 Application

The requirements of 10.4.1.4 shall apply in addition to the requirements of 10.4.5.5.

As a minimum, sampling shall be performed on completed ring gaskets and nonintegral metal seals in accordance with ISO 2859-1:1999, level II, 1.5 AQL.

For nonintegral metal seals, the hardness testing may be done on the raw material or at any intermediate stage of machining following the last heat-treatment cycle (including stress-relieving heat-treatment).

10.4.5.5.2 Test Method and Acceptance Criteria

A minimum of one hardness test per sample part shall be performed in accordance with procedures specified in ISO 6508 (all parts) or ASTM E18, geometry permitting. The location of the hardness test for ring gaskets shall be in accordance with Figure 6. The location for nonintegral metal seals shall be in accordance with the manufacturer's documented requirements.

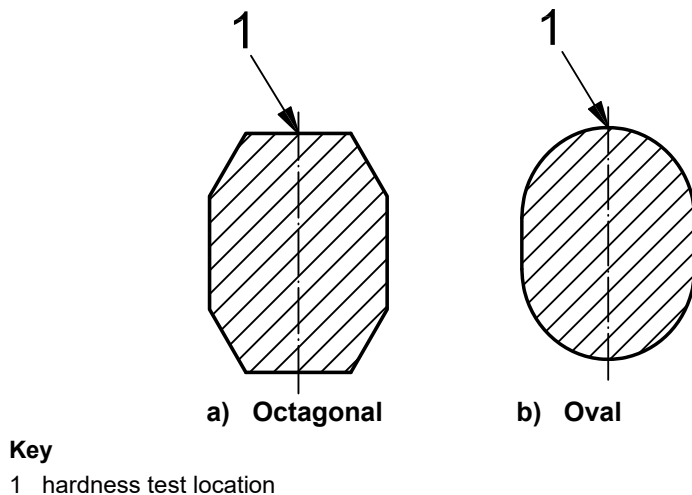

Figure 6—Ring Gasket Hardness Test Location

The acceptance criteria for ring gaskets shall be as given in Table 27.

For nonintegral metal seals, the acceptance criteria shall be per the manufacturer's documented requirements.

Table 27—Hardness Requirements

Material	Maximum Hardness HRBW
Soft iron	56
Carbon and low alloys	68
Stainless steel	83
Nickel alloy UNS N08825	92
Other CRAs	a
FOOTNOTE	
a Hardness shall meet the manufacturer's written specification.	

10.4.5.6 Surface Finish

Sampling shall be in accordance with the manufacturer's documented requirements.

The manufacturer's documented procedures shall be followed.

Acceptance criteria for ring gaskets are as given in Table 28. For nonintegral metal seals, the acceptance criteria shall be per the manufacturer's documented requirements.

Table 28—Acceptance Criteria for the Ring Gasket Surface Finish

Gasket Type	<i>Ra</i> μm	RMS μin.
R	1.6	63
RX	1.6	63
BX	0.8	32

10.4.6 Nonmetallic Seals

10.4.6.1 Application

This section shall apply to pressure-containing and pressure-controlling seals.

For PSL 1, PSL 2, PSL 3, and PSL 4, the requirements of 10.4.6 shall apply.

10.4.6.2 Hardness Testing

Sampling shall be performed in accordance with ISO 2859-1:1999, level II, 2.5 AQL for O-rings and 1.5 AQL for other seals.

Hardness testing shall be performed in accordance with procedures specified in ASTM D2240 or ASTM D1415. For materials not covered by these standards, hardness testing shall be per the manufacturer's specification.

The hardness shall be controlled in accordance with the manufacturer's written specification.

10.4.6.3 Dimensional Inspection

Dimensional inspection shall be performed on nonmetallic seals manufactured in accordance with this specification.

Sampling shall be performed on nonmetallic seals in accordance with ISO 2859-1:1999, level II, 2.5 AQL for O-rings and 1.5 AQL for other seals.

Each piece of the sample shall be dimensionally inspected for compliance to specified tolerances.

If inspection methods produce fewer rejections than allowed in sampling, the batch shall be accepted.

10.4.6.4 Visual Examination

Sampling shall be performed in accordance with ISO 2859-1:1999, level II, 2.5 AQL for O-rings and 1.5 AQL for other seals.

Each piece of the sample shall be visually inspected according to manufacturer's written requirements.

If inspection methods produce rejections less than allowed in sampling, the batch shall be accepted.

10.4.6.5 Documentation

NOTE 1 The documentation requirements do not apply to PSL 1.

For PSL 2, PSL 3, and PSL 4, the seal supplier shall certify that materials and end products meet manufacturer's specifications. Certification shall include manufacturer's part number, specification number, and compound number.

For PSL 3 and PSL 4, additionally, the following documentation shall be included:

- batch number/traceability;
- cure/mold date;
- shelf-life expiration date.

NOTE 2 These additional documentation requirements do not apply to PSL 2.

For PSL 4 only, the following additional documentation shall be included.

- The seal supplier shall supply a copy of test results of the physical properties of the compound supplied. Physical properties shall be in accordance with the manufacturer's written specification.
- Physical property data for qualification of homogeneous elastomers shall include the items given in Table 29.

Table 29—Physical Property Data for Qualification of Homogeneous Elastomers

Data	Documentation in Accordance with
Hardness testing	ASTM D1414 or ASTM D2240
Tensile testing	ASTM D412 or ASTM D1414
Elongation	ASTM D412 or ASTM D1414
Compression set	ASTM D395 or ASTM D1414
Modulus	ASTM D412 or ASTM D1414
Fluid immersion	ASTM D471 or ASTM D1414

Physical property data for other nonmetallic seal materials shall meet the requirements of the manufacturer's written specification.

NOTE 3 These additional documentation requirements do not apply to PSL 2 and PSL 3.

10.4.7 Assembled Equipment—General

10.4.7.1 Factory Acceptance Testing Requirements

For PSL 1, PSL 2, PSL 3, and PSL 4, the following factory acceptance testing (see Section 11) requirements shall apply.

All hydrostatic testing shall be performed prior to any gas testing.

NOTE The sequence of gas testing may be varied at the option of the manufacturer.

The drift test shall be performed after the equipment has been assembled, operated, and tested. The sequence of other tests shall be at the option of the manufacturer.

For hydrostatic or gas testing, visible leakage (see 3.1.107) shall be any release of test fluid observed during the pressure hold period. Fluid released during pressure build-up or pressure bleed-down shall not be recognized as visible leakage. Visible leakage shall be observed directly, including through a window, or by video equipment.

If video equipment is used in place of direct observation, adequate resolution and brightness shall be maintained to determine possible leakage.

10.4.7.2 Traceability Record

For PSL 3 and PSL 4, a report identifying the body, bonnet, stem, end and outlet connector, and valve bore sealing mechanisms shall be listed traceable to the assembly.

NOTE The traceability requirements do not apply to PSL 1 and PSL 2.

10.4.7.3 Assembly Serialization

For PSL 2, PSL 3, and PSL 4, serialization of valves, wellhead equipment, tees, crosses, tubing-head adapters, hangers, chokes, and back-pressure valves shall be required.

NOTE The serialization requirements do not apply to PSL 1.

10.4.8 Mandrel-type Hangers

10.4.8.1 General

Section 10.4.8 shall apply to mandrel-type hangers, including casing and tubing hanger mandrels.

10.4.8.2 Tensile Testing

For PSL 1, PSL 2, PSL 3, and PSL 4, tensile testing shall be in accordance with 6.3.2.2.

10.4.8.3 Impact Testing

For PSL 1, PSL 2, PSL 3, and PSL 4, impact testing shall be in accordance with 6.3.2.3.

10.4.8.4 Hardness Testing

10.4.8.4.1 Application

The requirements of 10.4.1.4 shall apply.

Additionally, the hardness testing requirements of 10.4.8.4 shall apply to PSL 1, PSL 2, PSL 3, and PSL 4.

Each part shall be hardness tested.

Additionally, for PSL 3 and PSL 4, a minimum of one additional hardness test shall be performed as specified in the manufacturer's design document.

NOTE The additional requirement does not apply to PSL 1 and PSL 2.

10.4.8.4.2 Test Method and Acceptance Criteria

Hardness testing shall be performed in accordance with procedures specified in ISO 6506 (all parts) or ISO 6508 (all parts), or ASTM E10 or ASTM E18. Perform test at a location determined by the manufacturer's specifications and following the last heat-treatment (including all stress-relieving heat-treatment cycles) and all exterior machining.

Acceptance criteria shall be in accordance with the manufacturer's specification.

10.4.8.5 Dimensional Inspection

10.4.8.5.1 Application

Dimensional inspection shall be performed on casing and tubing hanger mandrels manufactured in accordance with this specification. The manufacturer shall specify critical dimensions.

The dimensional testing requirements of 10.4.8.5 shall apply to PSL 1, PSL 2, PSL 3, and PSL 4.

All suspension, lift, and back-pressure valve threads or retention profiles shall be gauged. Critical dimensions on all parts shall be verified.

Additionally, for PSL 3 and PSL 4, dimensional inspection shall be performed on all parts.

NOTE The additional requirement does not apply to PSL 1 and PSL 2.

10.4.8.5.2 Test Method and Acceptance Criteria

The connectors shall be gauged for standoff at hand-tight assembly by use of the gauges and gauging practices illustrated in Table D.29/Table E.29 and Table D.30/Table E.30.

Acme and other parallel thread profiles shall be dimensionally inspected in accordance with the manufacturer's specifications.

Acceptance criteria for critical dimensions shall be in accordance with the manufacturer's specification. The end and outlet connector threads shall be in accordance with Table D.29/Table E.29 and Table D.30/Table E.30; or with API 5B; or with ASME B1.1, ASME B1.2, and ASME B1.3, as applicable.

10.4.8.6 Visual Examination

The visual examination requirements of 10.4.8.6 shall apply to PSL 1 and PSL 2.

NOTE The visual examination requirements do not apply to PSL 3 and PSL 4.

Each part shall be visually examined.

Visual examination shall be performed on wrought material in accordance with the manufacturer's written specifications.

Acceptance criteria for wrought material shall be in accordance with the manufacturer's written specifications.

10.4.8.7 Chemical Analysis

The chemical analysis requirements of 10.4.8.7 shall apply to PSL 1, PSL 2, PSL 3, and PSL 4.

Chemical analysis shall be performed on a heat of material.

Chemical analysis shall be performed in accordance with nationally or internationally recognized standards specified by the manufacturer.

The chemical composition shall meet the requirements of the manufacturer's written specification.

10.4.8.8 Traceability

For PSL 1 and PSL 2, the following shall apply.

- Job-lot traceability shall be required.
- Identification shall be maintained on materials and parts to facilitate traceability, as required by documented manufacturer requirements.
- Manufacturer-documented traceability requirements shall include provisions for maintenance or replacement of identification marks and identification control records.

NOTE 1 The PSL 1 and PSL 2 traceability requirements do not apply to PSL 3 and PSL 4.

For PSL 3 and PSL 4, parts shall be traceable to a specific heat and heat-treat lot.

NOTE 2 The PSL 3 and PSL 4 traceability requirements do not apply to PSL 1 and PSL 2.

10.4.8.9 Serialization

For PSL 3 and PSL 4, serialization requirements shall be in accordance with 10.4.2.9.

NOTE The serialization requirements do not apply to PSL 1 and PSL 2.

10.4.8.10 Surface NDE

For PSL 2, PSL 3, and PSL 4, surface NDE requirements shall be in accordance with 10.4.2.10 for ferromagnetic materials and 10.4.2.11 for nonferromagnetic materials, as applicable.

NOTE The surface NDE requirements do not apply to PSL 1.

10.4.8.11 Volumetric NDE

For PSL 3 and PSL 4, volumetric NDE requirements shall be in accordance with 10.4.2.12.

For PSL 4, additionally, volumetric NDE requirements shall include the following.

- 1) Acceptance criteria for the UT: Same acceptance criteria as PSL 3, with the addition that no continuous cluster of indications on the same plane, regardless of amplitude, shall be found over an area twice the diameter of the search unit.
- 2) Acceptance criteria for the radiographic testing shall be as follows:
 - no indication interpreted as a crack, lap, or burst;
 - no elongated indications exceeding 6.4 mm ($1/4$ in.);
 - no more than two indications separated by less than 13 mm ($1/2$ in.).

NOTE The volumetric NDE requirements do not apply to PSL 1 and PSL 2.

10.4.8.12 Weld NDE—General

For PSL 2 only, quality control requirements shall be in accordance with 10.4.2.14, 10.4.2.15, 10.4.2.16, and 10.4.2.19. Repair welding shall be in accordance with 7.4.

For PSL 3 only, general weld NDE requirements shall be in accordance with 10.4.2.13.

For PSL 4, no welding except overlay shall be permitted on PSL 4. Weld NDE requirements for overlay in PSL 4 shall be identical to the requirements for PSL 3.

NOTE The weld NDE requirements do not apply to PSL 1.

10.4.8.13 Weld Examination—Visual

For PSL 2 and PSL 3, visual weld examination requirements shall be in accordance with 10.4.2.14.

NOTE The visual weld examination requirements do not apply to PSL 1 and PSL 4.

10.4.8.14 Weld NDE—Surface

For PSL 2 and PSL 3, surface weld NDE requirements shall be in accordance with 10.4.2.15.

NOTE The surface weld NDE requirements do not apply to PSL 1 and PSL 4.

10.4.8.15 Weld NDE—Volumetric

For PSL 2 and PSL 3, volumetric weld NDE requirements shall be in accordance with 10.4.2.16.

NOTE The volumetric weld NDE requirements do not apply to PSL 1 and PSL 4.

10.4.8.16 Weld NDE—Hardness

10.4.8.16.1 Application

The hardness weld NDE requirements of 10.4.8.16 shall apply to PSL 2 and PSL 3.

NOTE The hardness weld NDE requirements do not apply to PSL 1 and PSL 4.

100 % of all accessible pressure-containing, nonpressure-containing, and repair welds shall be tested.

10.4.8.16.2 Test Method and Acceptance Criteria

Hardness testing shall be performed in accordance with procedures specified in ISO 6506 (all parts) or ASTM E10 or procedures specified in ISO 6508 (all parts) or ASTM E18.

At least one hardness test shall be performed both in the weld and in the adjacent unaffected base metals after all heat-treatment and machining operations.

Acceptance criteria shall be in accordance with the manufacturer's specifications.

The hardness recorded in the PQR shall be the basis for acceptance if the weld is not accessible for hardness testing.

10.4.8.17 Weld Overlay

For PSL 3 and PSL 4, surface NDE (preparation) requirements of 10.4.2.10 for ferromagnetic materials and 10.4.2.11 for nonferromagnetic materials shall apply.

NOTE 1 The surface NDE requirements for the weld preparation do not apply to PSL 1 and PSL 2.

For PSL 2, PSL 3, and PSL 4, surface NDE (completion) requirements of 10.4.2.15 shall apply.

NOTE 2 The surface NDE requirements for the weld completion do not apply to PSL 1.

For PSL 3 and PSL 4, volumetric NDE requirements of 10.4.2.18 shall apply.

NOTE 3 The volumetric NDE requirements do not apply to PSL 1 and PSL 2.

10.4.8.18 Repair Welds

For PSL 2 and PSL 3, repair weld requirements shall be in accordance with 10.4.2.19.

NOTE The repair weld requirements do not apply to PSL 1 and PSL 4.

10.4.9 Slip-type Hangers

10.4.9.1 Slip Bowls

10.4.9.1.1 Tensile Testing

Tensile testing of slip bowls shall be in accordance with 6.3.2.2.

10.4.9.1.2 Hardness Testing

Sampling shall be per the manufacturer's requirements.

Hardness testing shall be performed in accordance with procedures specified in ISO 6506 (all parts) or ISO 6508 (all parts), or ASTM E10 or ASTM E18. Perform test at a location determined by the manufacturer's specifications and following the last heat-treatment (including all stress-relieving heat-treatment cycles) and all exterior machining.

Acceptance criteria shall be in accordance with the manufacturer's specification.

10.4.9.1.3 Dimensional Inspection

Manufacturers shall identify critical dimensions for dimensional inspection. Slip bowls shall be inspected on a sample basis in accordance with ISO 2859-1:1999, level II, 1.5 AQL and the manufacturer's specifications.

10.4.9.1.4 Visual Examination

Each slip bowl shall be visually examined.

Visual examination shall be performed in accordance with the manufacturer's written specifications.

10.4.9.1.5 Chemical Analysis

Chemical analysis shall be performed on a heat of material.

Chemical analysis shall be performed in accordance with nationally or internationally recognized standards specified by the manufacturer.

The chemical composition shall meet the requirements of the manufacturer's written specification.

10.4.9.1.6 Traceability

Job-lot traceability shall be required.

Identification shall be maintained on slip bowls, as specified by the manufacturer's requirements.

10.4.9.2 Slip Segments

10.4.9.2.1 Dimensional Inspection

Manufacturers shall identify critical dimensions for dimensional inspection. Slip segments shall be inspected on a sample basis in accordance with ISO 2859-1:1999, level II, 1.5 AQL and the manufacturer's specifications.

10.4.9.2.2 Visual Examination

Each set of slip segments shall be visually examined.

Visual examination shall be performed in accordance with the manufacturer's written specifications.

10.4.9.2.3 Chemical Analysis

Chemical analysis shall be performed on a heat of material.

Chemical analysis shall be performed in accordance with nationally or internationally recognized standards specified by the manufacturer.

The chemical composition shall meet the requirements of the manufacturer's written specification.

10.4.9.2.4 Traceability

Job-lot traceability shall be required. Identification shall be maintained on slip segments, as specified by the manufacturer's requirements.

10.4.9.2.5 Slip Hardening

The hardening process shall be in accordance with the manufacturer's specification.

10.4.9.2.6 Threaded Fasteners

Threaded fasteners passing through or activating seals in slip hangers rated for material classes DD, EE, FF, or HH shall be in accordance with NACE MR0175/ISO 15156.

10.4.9.2.7 Records Control

Records shall be in accordance with PSL 1 of 15.2.

10.4.10 Bullplugs, Valve-removal Plugs, Back-pressure Valves, and Fittings

10.4.10.1 Application

Cast iron shall not be used.

Weld repair shall not be allowed.

Requirements for fittings shall be in accordance with the manufacturer's documented procedures.

NOTE PSLs are not applicable.

10.4.10.2 Tensile Testing

Tensile testing for bullplugs, back-pressure valve bodies, and valve-removal plug bodies shall be in accordance with 6.3.2.2.

10.4.10.3 Impact Testing

Impact testing for bullplugs, back-pressure valve bodies, and valve-removal plug bodies shall be in accordance with 6.3.2.3.

10.4.10.4 Hardness Testing

Hardness testing of bodies shall be in accordance with 10.4.2.4 for PSL 1. Hardness testing of metallic valve seal mechanisms on back-pressure valves for material classes DD, EE, FF, and HH shall be performed in accordance with 10.4.1.4.

NOTE Hardness testing is not required for those materials that have no hardness restriction specified by NACE MR0175/ISO 15156 or are excluded by NACE MR0175/ISO 15156, or for those materials that are not heat-treated to obtain a minimum specified strength level.

10.4.10.5 Dimensional Inspection

Dimensional inspection shall be in accordance with 10.4.2.5 for PSL 1. In addition, all threads or retention profiles shall be gauged.

10.4.10.6 Visual Examination

Visual examination shall be in accordance with 10.4.2.6 for PSL 1.

10.4.10.7 Chemical Analysis

Chemical analysis requirements shall be in accordance with 10.4.2.7 for PSL 2.

10.4.10.8 Traceability

Traceability requirements shall be in accordance with 10.4.2.8 for PSL 2.

10.4.10.9 Factory Acceptance Testing for Back-pressure Valves

NOTE See 11.2.6.

11 Factory Acceptance Testing

11.1 General

11.1.1 Scope and Applicability

This section specifies pressure testing, drift testing, and functional testing requirements for production units. Equipment listed in column 1 of Table 30 shall be tested in conformance with these requirements.

Factory acceptance testing for actuators shall be performed in conformance with all applicable requirements of 14.16.4.

NOTE 1 Factory acceptance testing is not required for the equipment listed under the Nonpressure-tested Equipment column of Table 30.

Table 30—Applicability of Factory Acceptance Testing

Pressure-tested Equipment Factory acceptance testing (FAT) requirements identified in this specification	Nonpressure-tested Equipment No factory acceptance testing (FAT) requirements identified in this specification
<ul style="list-style-type: none"> • Valves (<i>flowline</i>) Gate, plug, and ball valves SSVs, USVs, BSDVs Check valves 	<ul style="list-style-type: none"> • Loose connectors Blind, test, and weld-neck flanges Blind, test, and weld-neck OECs
<ul style="list-style-type: none"> • Back-pressure valves • Fittings/pressure boundary penetrations (<i>installed in assembled equipment</i>) • Chokes 	<ul style="list-style-type: none"> • Bullplugs • Valve-removal plugs • Loose fittings (<i>and other pressure boundary penetrations</i>)
<ul style="list-style-type: none"> • Actuators (<i>for valves or chokes</i>) Hydraulic actuators Pneumatic actuators Electric actuators 	<ul style="list-style-type: none"> • Casing and tubing hangers Mandrel-type hangers Slip-type hangers
<ul style="list-style-type: none"> • Casing and tubing heads (<i> housings and adapters</i>) • Adapter and spacer spools • Tees and crosses 	<ul style="list-style-type: none"> • Ring gaskets • Other metal seals • Packing mechanisms for lock screws, alignment pins, and retainer screws
<ul style="list-style-type: none"> • Crossover connectors • Top connectors • Tree assemblies 	<ul style="list-style-type: none"> • Replacement parts Stems Lock screws Valve bore sealing mechanisms (<i>gates, seats, plugs, balls, etc.</i>) Choke trim

NOTE 2 A summary of the testing required is provided in Table 31.

Table 31—Summary of Factory Acceptance Testing Requirements by Equipment Type and PSL

Equipment Type	Hydrostatic Testing (PSL)			Gas Testing (PSL)			Drift Test (PSL)
	Shell Test	Seat Test	Function Test	Body ^c Test	Valve Seat Test	Backseat Test	
Valves (<i>flowline</i>)	1, 2, 3, 4	1, 2, 3, 4	2, 3, 4	3G, 4	3G, 4	3G ^d , 4	1, 2, 3, 4
Chokes	1, 2, 3, 4	—	—	3G, 4	—	—	—
Tree assemblies	✓ ^b	—	—	—	—	—	✓
Casing and tubing heads, housings, and adapters	1, 2, 3, 4	—	—	3G, 4	—	—	—
Adapter and spacer spools Tees and crosses Crossover connectors Top connectors	1, 2, 3, 4	—	—	3G, 4	—	—	—
Actuators ^{a,e}	✓	✓	✓	—	—	—	—
Back-pressure valves ^a	—	✓	—	—	—	—	—
FOOTNOTES							
^a PSLs are not applicable to this equipment.							
^b See 11.2.3.3 for test pressure requirements.							
^c Body test pressure = rated working pressure.							
^d Optional.							
^e See 14.16.4 for factory acceptance testing requirements.							
✓ = test applies/PSL does not apply.							

11.1.2 Measurement, Monitoring, and Recording Equipment

Pressure-measuring and pressure-recording devices shall be maintained and calibrated in conformance with 10.2.2. The range and resolution of pressure-measuring and pressure-recording devices shall conform to 10.2.2.

If a pressure chart recorder is not calibrated to meet the accuracy required by 10.2.2, it shall be used in parallel with a calibrated pressure gauge, and the pressure indicated by the calibrated gauge at the start and at the end of the hold period shall be written on the chart.

NOTE Pressure charts are not required for gas testing, compared with water, because a large volume change of gas is required to produce a significant change in pressure.

11.1.3 Test Sequence

The tests specified in this section shall be performed in a sequence that conforms to the following requirements.

- a) The hydrostatic shell test shall be the first pressure test performed.
- b) All hydrostatic pressure tests and functional tests shall be performed prior to any gas testing.

NOTE The sequence of gas testing may be varied at the option of the manufacturer.

- c) Drift testing of valves and tree assemblies shall be performed last, after all required pressure tests and functional tests.
- d) If a conditional body test is applicable to hydrostatic and/or gas testing (see 11.2.5 and 11.3.6), it shall be completed at a time when the test can be performed with all fittings and other pressure boundary penetrations installed and not removed afterwards.

11.1.4 Leak Detection

For hydrostatic or gas testing, visible leakage (see 3.1.107) shall be any release of test fluid observed during the pressure hold period. Fluid released during pressure build-up or pressure bleed-down shall not be considered leakage. Visible leakage shall be observed directly, including through a window, or by video equipment.

When video equipment is used in place of direct observation, resolution and brightness shall be sufficient to determine whether leakage occurs.

11.2 Hydrostatic Testing

11.2.1 Hydrostatic Testing—General Requirements

All hydrostatic testing of 11.2 shall conform to the requirements of this section.

- Test fluid shall be water or water with additives.
- If a body includes an integral API flange connector, it shall be acceptable to use a test fixture with nonmetallic seals for the API flange connection. Nonmetallic seals, placed in the flow bore, shall be within half of flange thickness from the bore entrance
- Test fixtures shall not apply additional stress to the body under test.
- All hold periods shall not start until the test article and the pressure measuring/recording equipment has been isolated from the pressure source and the external surfaces of the shell members have been thoroughly dried.

- All pressure testing shall be conducted prior to the addition of body-filler grease. Lubrication applied during assembly is acceptable.
- Testing shall be performed prior to painting; however, if the body and other pressure-containing parts are constructed of wrought material, tests may be completed after painting.
- If possible, all fittings and other pressure boundary penetrations should be installed during testing, with the secondary sealing device removed or compromised if the design has that capability. If any fitting or pressure boundary penetration was not installed during the last pressure-holding period, a conditional test of 11.2.5 shall be performed.

NOTE This does not apply to dual barrier applications or buried check valves.

11.2.2 Hydrostatic Test Acceptance Criteria

The acceptable criteria specified below shall be applied to shell tests, seat tests, and conditional hydrostatic body tests. For PSL 1, PSL 2, PSL 3, and PSL 4, the acceptance criteria shall be as follows.

- a) The equipment shall show no visible leakage while subjected to test pressure, except as specified otherwise in 11.2.2.c) or 11.2.2.d).
- b) For the hold period, the following shall apply:
 - At the start of the hold period, monitored pressure shall not be greater than 5 % above the specified test pressure.
 - During the hold period, the pressure shall not vary from the pressure at the start of the hold period by more than 5% or 3.45 MPa (500 psi), whichever is less.
 - Monitored pressure shall not be less than the specified test pressure.
- c) Leakage past the thread during the hydrostatic shell test of a threaded wellhead member when joined with a threaded test fixture is permissible above the working pressure of the thread. Threaded connections that leak at above working pressure shall have an additional hold period performed at working pressure with no visible leakage. This hold period shall be of the same duration as the secondary pressure-holding period.
- d) For metal seating check valves, the maximum allowable through-bore leakage in hydrostatic seat testing shall be in accordance with ISO 5208 Rate E.

11.2.3 Hydrostatic Shell Test

11.2.3.1 Test Method—PSL 1, PSL 2, PSL 3, and PSL 4

For PSL 1, PSL 2, PSL 3, and PSL 4, the following shall apply.

If a shell test is specified in Table 31, each piece of equipment shall be hydrostatically shell tested prior to shipment from the manufacturer's facility. The hydrostatic shell test shall be the first pressure test performed.

The general requirements of 11.1 and 11.2.1 shall apply.

Valves and chokes shall be in the partially open position during testing; test pressure shall not be applied as a differential pressure across closure mechanisms of valves or chokes.

The hydrostatic shell test for assembled equipment shall consist of three parts:

- a) primary pressure-holding period;

- b) reduction of the pressure to 0 psig;
- c) secondary pressure-holding period.

After testing, the pressure in the test article shall be reduced to 0 psig.

11.2.3.2 Hold Periods

The duration of pressure-holding periods shall be as specified in Table 32.

Table 32—Pressure-holding Periods for Hydrostatic Testing

		PSL 1	PSL 2	PSL 3	PSL 3G	PSL 4
Shell Test (See 11.2.3)	Primary hold period	3 min	3 min	3 min	3 min	3 min
	Secondary hold period	3 min	3 min	15 min	15 min	15 min
Seat Test(s) (See 11.2.4)	Primary hold period	3 min	3 min	3 min	3 min	3 min
	Secondary hold period	3 min	3 min	15 min	3 min	15 min
	Tertiary hold period	—	3 min	15 min	3 min	15 min

11.2.3.3 Test Pressure

For PSL 1, PSL 2, PSL 3, and PSL 4, the following shall apply.

The hydrostatic shell test pressure requirement shall be based on the rated working pressure and equipment type in accordance with Table 33, with the following supplemental requirements applied.

- a) For equipment with end or outlet connectors having different rated working pressures, the lowest working pressure rating shall be used to determine the hydrostatic shell test pressure (except for crossover connectors and chokes).
- b) For a crossover connector, the test pressure shall be based on the rated working pressure for the upper connector. Test pressure shall be applied inside and above the restricted-area packoff of the lower connector. The lower connector shall be tested below the restricted-area packoff with test pressure based on its rated working pressure.
- c) For a choke having an inlet connector with a higher rated working pressure than the outlet connector, two hydrostatic shell tests shall be performed. The body portion from the inlet connector to the body-to-bean seal point of the replaceable seat or flow bean shall be tested at the shell test pressure for the inlet connector. The remainder of the body, downstream from the seal point, shall be tested at the shell test pressure for the outlet connector. Temporary seat seals and/or a blank seat may be used to facilitate testing.
- d) For trees, the shell test pressure of Table 33 shall apply, with one exception: trees assembled entirely with equipment, excluding loose connectors, that has been previously hydrostatically shell tested, shall be tested either to the test pressure of Table 33 or to rated working pressure.
- e) Each bore of multiple-bore equipment shall be tested individually.

11.2.3.4 Acceptance Criteria

For PSL 1, PSL 2, PSL 3, and PSL 4, the acceptance criteria shall be as specified in 11.2.2.

Table 33—Hydrostatic Shell Test Pressure

Working Pressure Rating	Hydrostatic Shell Test Pressure						
	Nominal Size of Flange mm (in.)		Line Pipe and Tubing Threads	Casing Threads mm (in.)			
	346 (13 ⁵ / ₈) and smaller	425 (16 ³ / ₄) and larger		114.3 to 273.1 (4 ¹ / ₂ to 10 ³ / ₄)	298.5 to 339.7 (11 ³ / ₄ to 13 ³ / ₈)	406.5 to 508.0 (16 to 20)	
MPa (psi)	MPa (psi)	MPa (psi)	MPa (psi)	MPa (psi)	MPa (psi)	MPa (psi)	
13.8 (2000)	27.6 (4000)	20.7 (3000)	27.6 (4000)	27.6 (4000)	27.6 (4000)	27.6 (4000)	15.5 (2250)
20.7 (3000)	41.4 (6000)	31.0 (4500)	41.4 (6000)	41.4 (6000)	41.4 (6000)	31.0 (4500)	— —
34.5 (5000)	51.7 (7500)	51.7 (7500)	51.7 (7500)	51.7 (7500)	51.7 (7500)	— —	— —
69.0 (10,000)	103.5 (15,000)	103.5 (15,000)	103.5 (15,000)	— —	— —	— —	— —
103.5 (15,000)	155.0 (22,500)	155.0 (22,500)	— —	— —	— —	— —	— —
138.0 (20,000)	207.0 (30,000)	— —	— —	— —	— —	— —	— —

11.2.4 Hydrostatic Seat Tests and Functional Tests—Valves

11.2.4.1 Test Method—PSL 1

For PSL 1, the following shall apply.

- a) The general requirements of 11.1 and 11.2.1 shall apply.
- b) Hydrostatic test pressure shall be not less than the rated working pressure of the valve. Pressure shall be applied to one side, including connection, of the closed gate, ball, or plug of the valve, with the other side vented to atmosphere. Unidirectional valves shall be tested in the direction indicated on the body, except for check valves, which shall be tested from the downstream side.

NOTE 1 Split-gate valves may have both seats tested simultaneously.

- c) The valve shall be monitored for leakage and the pressure monitored for a minimum of 3 min.
- d) Test pressure shall be reduced to 0 psig.
- e) Steps b) through d) shall be repeated.
- f) For a bidirectional valve, steps b) through e) shall be performed on the other side of the gate, ball, or plug using the same procedure outlined above.

NOTE 2 PSL 1 hydrostatic seat test method requirements do not apply to PSL 2, PSL 3, PSL 3G, or PSL 4.

11.2.4.2 Test Method—PSL 2, PSL 3, and PSL 4

For PSL 2, PSL 3, and PSL 4, the following shall apply.

- a) The general requirements of 11.1 and 11.2.1 shall apply.
- b) Hydrostatic test pressure shall be not less than the rated working pressure of the valve. Pressure shall be applied to one side, including connection, of the closed gate, ball, or plug of the valve, with the other

side vented to atmosphere. Unidirectional valves shall be tested in the direction indicated on the body, except for check valves, which shall be tested from the downstream side.

NOTE 1 Split-gate valves may have both seats tested simultaneously.

- c) Pressure shall be monitored, and the valve shall be monitored for leakage, for the primary hold period specified in Table 32, as a minimum.
- d) The valve, except for check valves, shall be opened while still under full differential pressure. For PSL 3 and PSL 4 only, the operating torque for manual valves or supply pressure/electric current for actuated valves while operating under full differential pressure shall be measured.

NOTE 2 Measurement of torque or actuator input is not required for PSL 2.

- e) Test pressure shall be applied a second time to the same side of the gate, ball, or plug.
- f) Pressure shall be monitored, and the valve shall be monitored for leakage, for the secondary hold period specified in Table 32, as a minimum.
- g) The valve, except for check valves, shall be opened a second time while still under full differential pressure. For PSL 3 and PSL 4 only, the operating torque for manual valves or supply pressure/electric current for actuated valves while operating under full differential pressure shall be measured.
- h) Test pressure shall be applied a third time to the same side of the gate, ball, or plug.
- i) Pressure shall be monitored, and the valve shall be monitored for leakage, for the tertiary hold period specified in Table 32, as a minimum.
- j) Test pressure shall be reduced to 0 psig.

NOTE 3 The valve is not opened under differential pressure after the tertiary seat test.

- k) For a bidirectional valve, steps b) through j) shall be performed on the other side of the gate, ball, or plug using the same procedure outlined above.

NOTE 4 PSL 2, PSL 3, and PSL 4 hydrostatic valve seat test requirements do not apply to PSL 1.

11.2.4.3 Acceptance Criteria

For PSL 1, PSL 2, PSL 3, and PSL 4, the acceptance criteria shall be as specified in 11.2.2.

Additionally, for PSL 3 and PSL 4 valves only, the measured operating torque for manual valves or supply pressure/electric current for actuated valves, while operating under full differential pressure, shall be within the manufacturer's specified requirements.

11.2.5 Conditional Hydrostatic Body Test—PSL 1, PSL 2, and PSL 3

If any fitting or pressure boundary penetration was not installed during the last pressure-holding period, a conditional hydrostatic body test shall be performed with all fittings or pressure boundary penetrations installed.

- The general requirements of 11.1 and 11.2.1 shall apply.
- If a pressure boundary penetration contains an independent secondary barrier as defined by the manufacturer, the secondary barrier shall not be used during the conditional body test.

- A single pressure-holding period of no less than 3 min shall be performed.
- The test pressure shall be no less than the rated working pressure of the equipment.
- Acceptance criteria shall be in conformance with 11.2.2.

NOTE 1 A conditional gas body test conforming to 11.3.6 may be performed in lieu of the conditional hydrostatic body test of this section.

NOTE 2 The conditional hydrostatic body test requirements do not apply to PSL 4 equipment.

11.2.6 Hydrostatic Testing of Back-pressure Valves

Each back-pressure valve shall be hydrostatically tested by applying pressure across the full sealing bore of the back-pressure valve.

- The general requirements of 11.1 and 11.2.1 shall apply.
- Test pressure shall be the rated working pressure as a minimum.
- A single pressure-holding period is required and shall be no less than 3 min.
- Acceptance criteria shall be in conformance with 11.2.2.

NOTE Seals may be replaced after testing.

11.3 Gas Testing—PSL 3G and PSL 4

11.3.1 Gas Testing—General Requirements

All gas testing shall conform to the requirements of this section.

- The test medium shall be air, nitrogen, or other gas mixture that will remain in the gas phase at test pressure.
- Gas testing shall be performed at ambient temperature and with the tested equipment completely submerged in a water bath, with exception per NOTE 1.

NOTE 1 Actuator components (e.g. electric motors) and manual valve drivetrain components (e.g. thrust bearings) may be excluded from submersion completely if all retained fluid pressure-containing parts, seals, and other potential leak points or the outlet of vent ports are submerged to ensure that leakage is observable.

- Hold periods shall not start until the test article and the pressure measuring/recording equipment has been isolated from the pressure source and the pressure source bled to zero.
- All pressure testing shall be conducted prior to the addition of body-filler grease. Lubrication applied during assembly shall be acceptable. Testing shall be performed prior to painting, with exception per NOTE 2.

NOTE 2 If the body and other pressure-containing parts are constructed of wrought material, testing may be performed after painting.

- If possible, all fittings and other pressure boundary penetrations should be installed during testing, with the secondary sealing device removed or compromised if the design has that capability. If any fitting or pressure boundary penetration was not installed during the last pressure-holding period, a conditional gas body test of 11.3.6 shall be performed.

NOTE 3 This does not apply to dual barrier applications or buried check valves.

- Nonmetallic seals shall not be used in body gas testing on API flange connectors of equipment with API flange connectors.

11.3.2 Gas Test Acceptance Criteria—General Requirements

The acceptance criteria specified below shall be applied to gas body tests, seat tests, backseat tests, and conditional gas body tests.

For PSL 3G and PSL 4 gate valves, ball valves, plug valves, and soft-seated check valves, the following shall apply.

- a) No visible leakage (bubbles) shall appear in the water bath during the pressure-holding period.
- b) The maximum acceptable reduction of the gas test pressure shall be 2.0 MPa (300 psi) if there is no visible leakage in the water bath during the hold period.
- c) For PSL 3G metal-sealing check valves, the maximum allowable leakage shall be in conformance with ISO 5208 Rate C.

11.3.3 Gas Body Test

11.3.3.1 Test Method—PSL 3G and PSL 4

PSL 3G and PSL 4 equipment for which a gas body test is specified in Table 31 shall be subjected to the test of this section in addition to the hydrostatic shell test.

- The general requirements of 11.1 and 11.3.1 shall apply.
- Valves and chokes shall be in the partially open position during testing.
- The gas body test shall consist of a single pressure-holding period of not less than 15 min.
- The test pressure shall not be less than the rated working pressure of the equipment.

NOTE The gas body test requirements do not apply to PSL 1 and PSL 2.

11.3.3.2 Acceptance Criteria

For PSL 3G and PSL 4, the acceptance criteria shall be in accordance with 11.3.2.

11.3.4 Gas Seat Test—Valves

11.3.4.1 Test Method—PSL 3G and PSL 4

For PSL 3G and PSL 4, gas seat testing shall be performed as follows.

- a) The general requirements of 11.1 and 11.3.1 shall apply.
- b) Primary (RWP) gas seat test:
 - 1) Gas test pressure shall be not less than the rated working pressure of the valve. Pressure shall be applied to one side, including connection, of the closed gate, ball, or plug, with the other side vented

to the water bath. Unidirectional valves shall be tested in the direction indicated on the body, except for check valves, which shall be tested from the downstream side.

NOTE Split-gate valves may have both seats tested simultaneously.

- 2) Pressure shall be monitored, and the valve shall be monitored for leakage, for a minimum of 15 min.
 - 3) Test pressure shall be reduced to 0 psig.
 - 4) The valve, except for check valves, shall be fully opened and fully closed between primary and secondary tests.
- c) Secondary (low-pressure) gas seat test:
- 1) The applicable test pressure specified below shall be applied to the same side, including connection, of the closed gate, ball, or plug.
 - 2) For PSL 3G valves, the secondary seat test pressure shall be 2.0 MPa (300 psi) \pm 10 %.
 - 3) For PSL 4 valves, the secondary seat test pressure shall be greater than 5 % and less than 10 % of the rated working pressure.
 - 4) Pressure shall be monitored, and the valve shall be monitored for leakage, for a minimum of 15 min.
 - 5) Test pressure shall be reduced to 0 psig.
- d) For a bidirectional valve, steps b) and c) shall be performed on the other side of the gate, ball, or plug using the same procedure outlined above.

11.3.4.2 Acceptance Criteria

For PSL 3G and PSL 4 gate valves, ball valves, and plug valves, acceptance criteria for the primary gas seat test shall be in accordance with 11.3.2.

For PSL 3G and PSL 4 gate valves, ball valves, and plug valves, acceptance criteria for the secondary gas seat test shall be no visible leakage in the water bath during the holding periods with a maximum allowable reduction of gas test pressure of 0.2 MPa (30 psi).

11.3.5 Gas Backseat Test—Gate Valves

11.3.5.1 Applicability

If required by the manufacturer or purchaser, the test shall be performed as specified in this section.

For PSL 4 gate valves, a gas backseat test shall be performed on all gate valves.

NOTE 1 For PSL 3G gate valves, a gas backseat test is optional.

NOTE 2 The backseat test may be performed in conjunction with other gas tests if the gas pressure is applied to the backseat without restriction and any leakage is observable.

NOTE 3 The backseat gas test requirements do not apply to PSL 1, PSL 2, or PSL 3 (see NOTE 1).

11.3.5.2 Test Method—PSL 3G and PSL 4

For PSL 3G (when applicable) and PSL 4, gas backseat testing shall be performed as follows.

- a) The general requirements of 11.1 and 11.3.1 shall apply.

b) Primary (RWP) gas backseat test—PSL 3G and PSL 4:

- 1) Gas test pressure shall be not less than the rated working pressure of the valve. Pressure shall be applied to the valve such that the body cavity will be pressurized.

NOTE 1 If necessary to ensure that the full test pressure is applied to the backseat, both end connectors may be blanked off and the valve pressurized with the gate partially open when the backseat is engaged.

- 2) The area between the primary packing and the backseat, or other means for repacking the stuffing box, shall be vented during the test.
- 3) Pressure shall be monitored, and the valve shall be monitored for leakage, for a minimum of 15 min.
- 4) Test pressure shall be reduced to 0 psig.

c) Secondary (low-pressure) gas backseat test—PSL 4 only:

NOTE 2 The secondary gas backseat test is not applicable to PSL 3G valves.

- 1) The applicable test pressure specified below shall be applied such that the body cavity will be pressurized.
- 2) The secondary seat test pressure shall be greater than 5 % and less than 10 % of the rated working pressure.
- 3) Pressure shall be monitored, and the valve shall be monitored for leakage, for a minimum of 5 min.
- 4) Test pressure shall be reduced to 0 psig.

11.3.5.3 Acceptance Criteria

For PSL 3G and PSL 4 gate valves, acceptance criteria shall be in accordance with 11.3.2.

11.3.6 Conditional Gas Body Test

11.3.6.1 Applicability and Test Method—PSL 3G and PSL 4

If any fitting or pressure boundary penetration was not installed during the last gas test pressure-holding period, a conditional gas body test shall be performed with all fittings or pressure boundary penetrations installed.

- The general requirements of 11.1 and 11.3.1 shall apply.
- If a pressure boundary penetration contains an independent secondary barrier as defined by the manufacturer, the secondary barrier shall not be used during the conditional body test.
- A single pressure-holding period shall be performed. The hold period shall be no less than 3 min.
- The test pressure shall be no less than the rated working pressure of the equipment.

NOTE 1 A conditional gas body test conforming to 11.3.6 may be performed for PSL 1, PSL 2, or PSL 3 equipment in lieu of the conditional hydrostatic body test of 11.2.5.

NOTE 2 If a fitting or other pressure boundary penetration was removed during both the last hydrostatic test and the last gas test, a single conditional gas body test is sufficient to verify the seal integrity of all fittings and pressure boundary penetrations.

11.3.6.2 Acceptance Criteria

For PSL 3G and PSL 4 gate valves, acceptance criteria shall be in accordance with 11.3.2.

11.4 Drift Testing

11.4.1 Full-bore Valves

For PSL 1, PSL 2, PSL 3, and PSL 4, a drift mandrel conforming to Table 34 for valves shall be passed completely through the valve bore after the valve has been assembled, operated, and pressure-tested.

Table 34—Drift Dimensions for Individual Valves and Trees

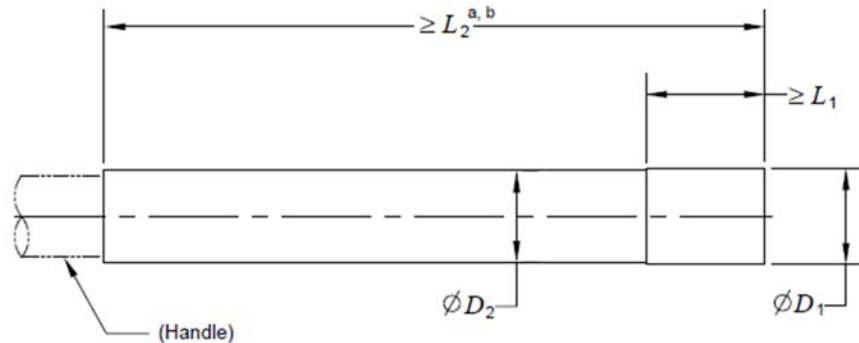

Dimensions in millimeters (inches)^c

Nominal Bore Size	L_1 minimum		D_1		D_2	
			$+0.69$ -0 mm ($+0.027$ -0 in.)		$+0.69$ -0 mm ($+0.027$ -0 in.)	
in.	mm	(in.)	mm	(in.)	mm	(in.)
1 ³ / ₁₆	76	(3.00)	45.21	(1.78)	38.6	(1.52)
2 ¹ / ₁₆	76	(3.00)	51.56	(2.03)	48.3	(1.90)
2 ⁹ / ₁₆	76	(3.00)	64.26	(2.53)	59.7	(2.35)
3 ¹ / ₁₆	78	(3.06)	76.96	(3.03)	73.2	(2.88)
3 ¹ / ₈	79	(3.12)	78.49	(3.09)	73.2	(2.88)
4 ¹ / ₁₆	103	(4.06)	102.36	(4.03)	97.3	(3.83)
4 ¹ / ₈	105	(4.12)	103.89	(4.09)	100.8	(3.97)
4 ¹ / ₄	108	(4.25)	108.09	(4.22)	101.6	(4.00)
5 ¹ / ₈	130	(5.12)	129.29	(5.09)	126.2	(4.97)
6	152	(6.00)	151.64	(5.97)	148.8	(5.85)
6 ¹ / ₈	156	(6.12)	154.69	(6.09)	151.6	(5.97)
6 ³ / ₈	162	(6.38)	161.04	(6.34)	158.0	(6.22)
6 ⁵ / ₈	168	(6.62)	167.39	(6.59)	164.3	(6.47)
7 ¹ / ₁₆	179	(7.06)	178.56	(7.03)	175.5	(6.91)
7 ¹ / ₈	181	(7.12)	180.85	(7.09)	177.0	(6.97)
9	228	(9.00)	227.84	(8.97)	224.8	(8.85)
11	279	(11.00)	278.64	(10.97)	275.6	(10.85)

FOOTNOTES

^a For valves, L_2 = valve face-to-face length.

^b For trees, L_2 = 1065 mm (42 in.).

^c For USV and BSDV valves with nonstandard bores, see 11.4.2.

11.4.2 Valves with Nonstandard Bore Sizes

For USV and BSDV valves with nonstandard bore sizes, drift testing is optional. When a drift test is specified by the manufacturer, the drift tool dimensions shall be as follows:

where

B is nominal bore size,

F is the maximum face-to-face length of the valve (for valves per Table D.22/Table E.22 and Table D.23/Table E.23), and

L_1 , L_2 , D_1 , and D_2 are drift dimensions shown in Table 34,

the following shall apply:

$$L_1 \geq B$$

$$L_2 \geq F$$

$$D_1 = B - 0.76 \text{ mm} (= B - 0.03 \text{ in.})$$

$$D_2 = D_1 - 3.30 \text{ mm} (= D_1 - 0.13 \text{ in.})$$

$$+ \text{ tolerance for } D_1 \text{ \& } D_2 = +0.69 \text{ mm} (= +0.027 \text{ in.})$$

$$- \text{ tolerance for } D_1 \text{ \& } D_2 = -0$$

11.4.3 Tree Assemblies

For PSL 1, PSL 2, PSL 3, and PSL 4, a drift mandrel conforming to Table 34 for trees shall be passed completely through the main bore of a tree assembly.

12 Equipment Marking

12.1 Marking Requirements

Equipment shall be marked on the exterior surface as specified in Table 35 and the product-specific requirements in Section 14. The nominal size for equipment shall be marked with US Customary (USC) units.

12.2 Marking Method

Marking using low-stress (dot, vibration, or rounded V) stamps shall be acceptable. Conventional sharp V-stamping shall be permitted only in low-stress areas, such as the outside diameter of flanges.

NOTE The method used for marking on nameplates is not specified.

12.3 Nameplates

Unless nameplates are specified, marking shall be applied on the nameplate and/or the body or the connector.

12.4 Hidden Marking

Marking required on a connector outside diameter that would be covered by clamps or other parts of the connector assembly shall be stamped in a visible location near the connector.

Table 35—Guide to Marking Requirements ^{a,b,c}

Equipment Type	Nameplate Required?	Marking Requirements
Loose Fittings and Connectors		
• Integral, blind, and test flanges	Optional	14.1.5
• Ring gaskets	Not applicable	14.2.5
• Threaded connectors	Optional	14.3.5
• Tees and crosses	Optional	14.4.5
• Bullplugs	Not applicable	14.5.5
• Valve-removal plugs	Not applicable	14.6.5
• Top connectors	Optional	14.7.5
• Crossover connectors	Optional	14.8.5
• Other end connectors	Not applicable	14.9.5
• Spools (adapter and spacer)	Optional	14.10.5
Valves		
• Complete assemblies	Optional	14.11.5
• Prepared for actuator	Optional	14.11.5
Back-pressure Valves	Not applicable	14.12.5
Slip-type and Mandrel-type Hangers	Not applicable	14.13.5
Casing and Tubing Heads	Optional	14.14.5
Chokes		
• Choke assemblies, adjustable	Optional	14.15.5
• Choke assemblies, positive (fixed)	Optional	14.15.5
• Choke beans, positive chokes	Not applicable	14.15.5
Actuators (for Valves and Chokes)	Optional	14.16.5
Safety Valves		
• Safety valves (SSV, USV, BSDV)	Required	14.17.5
• Safety valves prepared for actuator	Required	14.17.5
• Safety valve actuators (SSV, USV, BSDV)	Required	14.17.5
Tree Assemblies	Optional	14.18.5
Other		
• Fittings/pressure boundary penetrations	Not applicable	Section 9
FOOTNOTES		
^a Valves that satisfy the requirements of API 6FA can be marked per the requirements therein in addition to the requirements of this section.		
^b Marking for features that do not exist on a product is not applicable.		
^c PSL 3 products may be marked "PSL 3G" when the additional requirements of gas testing have been satisfied.		

12.5 Thread Marking

The thread type marking shall include the following, as applicable:

- line pipe: LP
- casing (short thread): STC
- casing (long thread): LC
- casing (buttress): BC
- casing (extreme line): XC
- tubing (nonupset): NU
- tubing (external-upset): EU

12.6 Size Marking

The size marking shall include the nominal size and, if applicable, the restricted or oversize bore.

12.7 Temperature Marking

Temperature classes (see 4.3.2) or maximum and minimum temperature ratings shall be at location specified.

12.8 Hardness Tests

If hardness tests are required for bodies, bonnets, or end and outlet connectors, the actual value of the hardness test shall be stamped on the part adjacent to the test location or documented by the manufacturer.

12.9 Ring Grooves

The following shall apply.

- a) Type 6B flanged and studded connectors shall be marked “R XX,” where “XX” is the ring groove number.

NOTE 1 This applies to connectors to be assembled with either “R” or “RX” ring gaskets.

NOTE 2 Some previous editions of this specification included extra-deep ring grooves for use only with Type RX gaskets.

- b) End connectors with RX 201, RX 205, RX 210, or RX 215 ring grooves shall be marked “RX ZZZ,” where “ZZZ” is the ring groove number.
- c) Type 6BX flanged and studded connectors shall be marked “BX YYY,” where “YYY” is the ring groove number.
- d) Ring groove marking on Type 16A clamp hub connectors shall be in accordance with API 16A.
- e) Ring groove marking on Type 17SS and 17SV connectors shall be in accordance with API 17D.
- f) If equipment has metal-overlaid, corrosion-resistant ring grooves, the ring groove type and number shall be followed by “CRA” to designate a corrosion-resistant alloy.

12.10 Clamp Hub End Connectors

Clamp hub end connectors shall be marked with the size and pressure rating followed by “API 16A.”

13 Storing and Shipping

13.1 Draining after Testing

All equipment shall be drained and lubricated after testing and prior to storage or shipment.

13.2 Corrosion Protection

Corrosion protection shall be applied to exposed (bare) metallic surfaces of steels with less than 15 % chromium on flange faces, weld bevel ends, exposed stems, and internal surfaces of the equipment using the manufacturer’s documented requirements. Corrosion protection provided by a corrosion inhibitor shall resist runoff at temperatures less than 50 °C (125 °F).

NOTE Corrosion protection is not required on CRA surfaces.

13.3 Sealing-surface Protection

Exposed sealing surfaces and seals shall be protected from damage or deterioration for shipping.

13.4 Assembly and Maintenance Instructions

The manufacturer shall furnish to the purchaser suitable drawings and instructions concerning field assembly and maintenance of wellhead and tree equipment, if requested.

13.5 Ring Gaskets

Loose ring gaskets shall be boxed or wrapped during shipping and storage.

13.6 Age Control and Storage of Nonmetallic Seals

The following shall apply.

- a) The manufacturer's written specified requirements for nonmetallic seals that are not assembled into equipment shall include the following minimum provisions:
 - age control;
 - indoor storage;
 - maximum temperature not to exceed 49 °C (120 °F);
 - protected from direct natural light;
 - stress conditions (see text below);
 - stored away from contact with liquids;
 - protected from ozone and radiographic damage.
- b) Packaging and storage of nonmetallic seals shall not impose tensile or compressive stresses sufficient to cause permanent deformation or other damage.

NOTE Recommendations are typically available from seal manufacturers. Where applicable, for a given seal design, rings of large inside diameter and relatively small cross-section may be formed into three equal super imposed loops to avoid creasing or twisting, but it is not possible to achieve this condition by forming just two loops.

- c) The manufacturer's written specified requirements for nonmetallic seals that are assembled into equipment shall include a procedure to document the preservation of seals assembled in PSL 4 product during storage until delivery.

14 Equipment-specific Requirements

14.1 Integral, Blind, and Test Flanges

14.1.1 General Application

14.1.1.1 Flange Types and Uses

NOTE 1 Three types of end and outlet flanges are covered by this specification: Types 6B, 6BX, and segmented (see Annex L).

NOTE 2 Types 6B and 6BX flanges may be used as integral, blind, or weld-neck flanges.

NOTE 3 Type 6B may be used as threaded flanges. Some type 6BX blind flanges may be used as test flanges.

14.1.1.2 Studded End Connectors

NOTE Studded outlet connections are of the ring-joint type and are designed with a flat face. Studded outlet connections with rated working pressure of 13.8 MPa, 20.7 MPa, and 34.5 MPa (2000 psi, 3000 psi, and 5000 psi) are intended for assembly to 6B through-bolted flanges and to Type 6BX flange sizes shown in Table D.7/Table E.7. Studded outlet connections with rated working pressure of 69.0 MPa, 103.5 MPa, and 138.0 MPa (10,000 psi, 15,000 psi, and 20,000 psi) are intended for assembly to 6BX through-bolted flanges.

14.1.2 Design

14.1.2.1 Pressure Ratings and Size Ranges of Flange Types

NOTE Types 6B and 6BX are designed for use in the combinations of nominal size ranges and rated working pressures as shown in Table 36.

Table 36—Rated Working Pressures and Size Ranges of Flanges

Rated Working Pressure MPa (psi)	Flange Size Range mm (in.)	
	Type 6B	Type 6BX
13.8 (2000)	52 to 540 (2 ¹ / ₁₆ to 21 ¹ / ₄)	679 to 762 (26 ³ / ₄ to 30)
20.7 (3000)	52 to 527 (2 ¹ / ₁₆ to 20 ³ / ₄)	679 to 762 (26 ³ / ₄ to 30)
34.5 (5000)	52 to 279 (2 ¹ / ₁₆ to 11)	346 to 540 (13 ⁵ / ₈ to 21 ¹ / ₄)
69.0 (10,000)	—	46 to 540 (1 ¹³ / ₁₆ to 21 ¹ / ₄)
103.5 (15,000)	—	46 to 476 (1 ¹³ / ₁₆ to 18 ³ / ₄)
138.0 (20,000)	—	46 to 346 (1 ¹³ / ₁₆ to 13 ⁵ / ₈)

14.1.2.2 Type 6B Flanges

14.1.2.2.1 General

NOTE Type 6B flanges are of the ring joint type and are not designed for face-to-face make-up. The connection make-up bolting force reacts on the metallic ring gasket.

The Type 6B flange shall be of the through-bolted or studded design.

14.1.2.2.2 Dimensions

The following shall apply.

a) Standard dimensions:

- Dimensions for Type 6B integral, blind, and threaded flanges shall be in accordance with Table D.1 (13.8 MPa)/Table E.1 (2000 psi), Table D.2 (20.7 MPa)/Table E.2 (3000 psi), Table D.3 (34.5 MPa)/Table E.3 (5000 psi).

NOTE 1 Raised face and/or counterbore are optional.

- Dimensions for ring grooves shall conform to Table D.8 (Type R)/Table E.8 (Type R).

b) Integral flange exceptions: When flanges are welded to equipment covered by this specification and serve as end or outlet connectors, they shall conform to the integral flange dimensions in Table D.1

(13.8 MPa)/Table E.1 (2000 psi), Table D.2 (20.7 MPa)/Table E.2 (3000 psi), Table D.3 (34.5 MPa)/Table E.3 (5000 psi), as applicable.

NOTE 2 Type 6B flanges used as end connectors on casing and tubing heads may have entrance bevels, counterbores, or recesses to receive casing and tubing hangers. The dimensions of such entrance bevels, counterbores, and recesses are not covered by this specification and may exceed the B dimension given in Table D.1 (13.8 MPa)/Table E.1 (2000 psi), Table D.2 (20.7 MPa)/Table E.2 (3000 psi), Table D.3 (34.5 MPa)/Table E.3 (5000 psi).

- c) Threaded flanges: Threads shall conform to the requirements of 4.3.1.2.
- d) Weld-neck flanges: For weld-neck flanges, the requirements of Annex J shall apply.

14.1.2.2.3 Flange Face

The flange face shall be flat or raised on the ring-joint side and shall be fully machined.

NOTE The flange back face may be fully machined or spot-faced at the bolt holes.

The flange back face or spot faces shall be parallel to the front face within 1° and the thickness after facing shall conform to the dimensions of Table D.1 (13.8 MPa)/Table E.1 (2000 psi), Table D.2 (20.7 MPa)/Table E.2 (3000 psi), Table D.3 (34.5 MPa)/Table E.3 (5000 psi).

14.1.2.2.4 Gaskets

Type 6B flanges shall use Type R or Type RX gaskets in accordance with 14.2.

14.1.2.2.5 Corrosion-resistant Ring Grooves

NOTE Type 6B flanges may be manufactured with corrosion-resistant overlays in the ring grooves.

CRA overlay thickness of the ring grooves shall conform to 7.5.1.2.2.

14.1.2.2.6 Ring Groove Surface

All 23° surfaces on R ring grooves shall have a surface finish no rougher than 1.6 μm R_a (63 $\mu\text{in.}$ RMS).

14.1.2.3 Type 6BX Flanges

14.1.2.3.1 General

NOTE 1 Type 6BX flanges are of the ring-joint type and are designed with a raised face. Depending on tolerances, the connection make-up bolting force can react on the raised face of the flange when the gasket has been properly seated. This support prevents damage to the flange or gasket from excessive bolt torque.

The Type 6BX flange shall be of the through-bolted or studded design.

NOTE 2 Face-to-face contact is not necessary for the proper functioning of Type 6BX flanges.

14.1.2.3.2 Dimensions

The following shall apply.

- a) Standard dimensions:

— Dimensions for 6BX integral flanges shall conform to Table D.7 (13.8–34.5 MPa)/Table E.7 (2000 to

5000 psi), Table D.4 (69.0 MPa)/Table E.4 (10,000 psi), Table D.5 (103.5 MPa)/Table E.5 (15,000 psi), Table D.6 (138.0 MPa)/Table E.6 (20,000 psi), as applicable.

- Dimensions for 6BX weld-neck flanges shall conform to Table D.7 (13.8–34.5 MPa)/Table E.7 (2000 to 5000 psi), Table D.4 (69.0 MPa)/Table E.4 (10,000 psi), Table D.5 (103.5 MPa)/Table E.5 (15,000 psi), Table D.6 (138.0 MPa)/Table E.6 (20,000 psi), as applicable.

NOTE These flanges are not available in all the same pressure ratings and sizes as the integral flanges covered by this specification.

- Dimensions for 6BX blind and test flanges shall conform to Table D.7 (13.8–34.5 MPa)/Table E.7 (2000 to 5000 psi), Table D.4 (69.0 MPa)/Table E.4 (10,000 psi), Table D.5 (103.5 MPa)/Table E.5 (15,000 psi), Table D.6 (138.0 MPa)/Table E.6 (20,000 psi), as applicable.

- Dimensions for ring grooves shall conform to Table D.11 (Type BX)/Table E.11 (Type BX).

b) Exceptions for integral flanges:

NOTE Type 6BX flanges used as end connectors on casing and tubing heads may have entrance bevels, counterbores, or recesses to receive casing and tubing hangers. The dimensions of such entrance bevels, counterbores, and recesses are not covered by this specification and may exceed the *B* dimension of the tables.

c) Weld-neck flanges: For weld-neck flanges, the requirements of Annex J shall apply.

14.1.2.3.3 Flange Face

The flange face on the ring-joint side shall be raised, except for studded flanges, which may have flat faces. Front faces shall be fully machined. The nut-bearing surface shall be parallel to the flange gasket face within 1°.

NOTE The back face may be fully machined or spot-faced at the bolt holes.

The thickness after facing shall conform to the dimensions of Table D.7 (13.8–34.5 MPa)/Table E.7 (2000 to 5000 psi), Table D.4 (69.0 MPa)/Table E.4 (10,000 psi), Table D.5 (103.5 MPa)/Table E.5 (15,000 psi), Table D.6 (138.0 MPa)/Table E.6 (20,000 psi), as applicable.

14.1.2.3.4 Gaskets

Type 6BX flanges shall use BX gaskets in accordance with 14.2.

14.1.2.3.5 Corrosion-resistant Ring Grooves

NOTE Type 6BX flanges may be manufactured with corrosion-resistant weld overlays in the ring grooves.

CRA overlay thickness of the ring grooves shall conform to 7.5.1.2.2.

14.1.2.3.6 Ring Groove Surface

All 23° surfaces on BX ring grooves shall have a surface finish no rougher than 0.8 μm *Ra* (32 μin . RMS).

14.1.2.4 Segmented Flanges

NOTE The dimensions for segmented flanges for dual completion are found in Annex L.

14.1.2.5 Studded Outlet Connectors

14.1.2.5.1 General

NOTE Typical usage includes studded crosses and tees, casing and tubing spools, and multiple valve blocks. (See Table D.14/Table E.14 for illustration.)

14.1.2.5.2 Dimensions

Referring to Table D.1 (13.8 MPa)/Table E.1 (2000 psi), Table D.2 (20.7 MPa)/Table E.2 (3000 psi), Table D.3 (34.5 MPa)/Table E.3 (5000 psi), Table D.7 (13.8–34.5 MPa)/Table E.7 (2000 to 5000 psi), Table D.4 (69.0 MPa)/Table E.4 (10,000 psi), Table D.5 (103.5 MPa)/Table E.5 (15,000 psi), Table D.6 (138.0 MPa)/Table E.6 (20,000 psi), the following dimensions shall apply to studded outlet connectors:

- B : maximum bore;
- BC : diameter of bolt circle;
- number of bolts;
- diameter of bolts.

NOTE Studded outlets in casing or tubing spools may have a preparation for a valve-removal plug, in which case the maximum bore dimension B does not apply.

Threaded bolt holes shall conform to ASME B1.1, Class 2B or 3B. Threads per inch (TPI) shall be as listed in the tables of Annex D, Annex E, or Annex L. The minimum depth of full thread shall be as specified in 14.1.2.6.2.

Ring groove dimensions shall conform to:

- Table D.8/Table E.8 for 6B studded outlet connectors; or
- Table D.11/Table E.11 for 6BX studded outlet connectors.

14.1.2.5.3 Outlet Face

The outlet face shall be fully machined and shall be of sufficient size to allow assembly of the corresponding 6B or 6BX flange. The raised face diameter shall not be required for 6B or 6BX studded connectors.

NOTE It is permissible for the outlet face to be in a circular counterbore that accepts the mating flange, with counterbore dimensions as specified by the manufacturer.

14.1.2.5.4 Gaskets

Studded outlet connections shall use R, RX or BX gaskets in accordance with 14.2.

14.1.2.5.5 Corrosion-resistant Ring Grooves

Studded outlet connectors may be manufactured with corrosion-resistant weld overlays in the ring grooves. CRA overlay thickness of the ring grooves shall conform to 7.5.1.2.2.

14.1.2.5.6 Ring Groove Surface

The 23° surface on R ring grooves shall have a surface finish no rougher than 1.6 μm R_a (63 μin . RMS).

The 23° surface on BX ring grooves shall have a surface finish no rougher than 0.8 μm R_a (32 μin . RMS).

14.1.2.6 End and Outlet Bolting

14.1.2.6.1 Hole Alignment

End and outlet bolt holes for flanges shall be equally spaced and shall straddle common centerlines.

14.1.2.6.2 Stud Thread Engagement

Stud thread-engagement length into the body for studded flanges shall be a minimum of one times the outside diameter of the stud.

14.1.2.6.3 Closure Bolting

All end and outlet closure bolting shall meet requirements of Section 8. The stud length shall be sufficient to allow assembly of the corresponding 6B or 6BX flange with full thread engagement of the nut. For 6B outlets, stud length shall also include allowance for the standoff for the R or RX gasket.

NOTE Recommended stud lengths for outlet connectors are provided in Annex I.

14.1.3 Materials

Material requirements for flanges shall conform to the requirements in Section 6.

Material requirements for studded outlet connectors shall be as specified in Section 6 for the corresponding 6B or 6BX flange.

14.1.4 Quality Control/Testing

Loose flanges shall not require a hydrostatic shell test prior to final acceptance.

14.1.5 Marking

Blind and test flanges shall be marked as specified in Section 12 and Table 37.

Table 37—Marking for Blind and Test Flanges

Required Markings	Required Location(s)
API 6A or 6A Temperature class(es) or ratings Material class Product specification level (PSL) Date of manufacture Manufacturer's name or mark Serial number (if applicable) Nominal bore size (if applicable) End and outlet connector size Rated working pressure Ring groove type and number	Outside diameter of connector
Hardness test values (if applicable) (see 12.8)	Adjacent to test location

Integral studded and flanged outlet connectors shall be marked as specified in Section 12 and Table 38.

Table 38—Marking for Studded and Flanged Outlet Connectors

Required Markings	Required Location(s)
API 6A or 6A Nominal bore size (if applicable) End and outlet connector size Rated working pressure Ring groove type and number	Outside diameter of flange or face of studded outlet

14.1.6 Storing and Shipping

All flanges shall be stored and shipped in accordance with Section 13.

14.2 Ring Gaskets

14.2.1 General

Types R or RX gaskets shall be used on 6B flanges with type R grooves. Only BX gaskets shall be used with 6BX flanges with type BX grooves.

NOTE RX and BX gaskets provide a pressure-energized seal but are not interchangeable. RX gaskets provide additional clearance between the flanges.

Ring gaskets have a limited amount of positive interference, which ensures that the gaskets are coined into a sealing relationship in the grooves and therefore gaskets shall not be reused.

14.2.2 Design

14.2.2.1 Dimensions

Ring gaskets shall conform to the dimensions and tolerances specified in Table D.9/Table E.9, Table D.10/Table E.10, and Table D.12/Table E.12 and shall be flat within a tolerance of 0.2 % of ring outside diameter to a maximum of 0.38 mm (0.015 in.).

14.2.2.2 R and RX Gaskets

For oval type R gaskets, the surface finish shall be no rougher than 1.6 μm Ra (63 $\mu\text{in. RMS}$) on the radiused surfaces.

For octagonal type R and RX gaskets, all 23° surfaces shall have a surface finish no rougher than 1.6 μm Ra (63 $\mu\text{in. RMS}$).

14.2.2.3 BX Gaskets

All 23° surfaces on BX gaskets shall have a surface finish no rougher than 0.8 μm Ra (32 $\mu\text{in. RMS}$).

Each BX gasket shall have one pressure-passage hole drilled through its height as shown in Table D.12/Table E.12.

14.2.3 Materials

14.2.3.1 General

14.2.3.1.1 Gasket Material

Ring gasket material shall meet the requirements of Section 6.

Ring gasket material shall conform to the manufacturer's written specification.

14.2.3.1.2 Coatings and Platings

Coating and plating thicknesses shall be 0.013 mm (0.0005 in.) maximum.

NOTE Coatings and platings may be employed to aid the seal engagement while minimizing galling and to extend shelf life.

14.2.3.2 Material Qualification Testing

The following requirements shall apply:

- tensile testing: none required;
- impact testing: none required;
- hardness requirements shall be as given in Table 27.

14.2.3.3 Processing

14.2.3.3.1 Melting, Casting, and Hot Working

The following requirements shall apply.

- a) Melting practices: The manufacturer shall select and specify the melting practice(s) used to fabricate ring gaskets. The melt shop shall use practices that produce homogeneous material, free from cracks, banding, piping, and flakes.
- b) Casting practices: Centrifugal casting shall be the only acceptable method of casting ring gaskets.
- c) Hot working practices: Wrought materials shall be hot worked throughout. Ring gaskets may be made from pierced tubing or pipe, rolled rings, or rolled and welded bar or plate.

14.2.3.3.2 Heat-treating

All heat-treating of parts shall be performed with equipment meeting the requirements of 6.5.

Heat-treatment operations shall be in accordance with the manufacturer's written specification.

Ring gaskets shall be either annealed, normalized, or solution-treated as the last stage of material processing prior to the final machining.

14.2.3.3.3 Chemical Composition

The chemistry of ring gaskets shall be as described in the manufacturer's written specification.

14.2.4 Quality Control/Testing

The requirements of 10.4.5 shall apply.

14.2.5 Marking

Ring gaskets shall be marked as specified in Table 39.

Table 39—Marking for Ring Gaskets

Marking Requirement	Marking	Location
Date of manufacture	(Month/Year)	Outside diameter of gasket
Manufacturer's name or mark	PMR	Outside diameter of gasket
Ring gasket type and number	Example: "BX 155"	Outside diameter of gasket
Ring gasket material code:		Outside diameter of gasket, following gasket type and number, with or without a dash Examples: "R 24-D" "RX 39 S316" "BX 169-825"
Soft iron	D	
Carbon or low-alloy steel	S	
304 Stainless steel	S304	
316 Stainless steel	S316	
Nickel alloy UNS N08825	825	
Other CRA materials	(UNS number)	

14.2.6 Storing and Shipping

Gaskets shall be stored and shipped in accordance with Section 13.

14.3 Threaded Connectors

14.3.1 General

The requirements for integral end and outlet connectors, including those on tubing and casing hangers, shall apply only to those that are threaded according to API 5B.

Other loose threaded end and outlet connectors shall be specified by the manufacturer.

14.3.2 Design

14.3.2.1 General

Internal and external thread dimensions and tolerances shall conform to API 5B or ASME B1.20.1, if applicable (see 14.3.2.3).

- a) Thread lengths: The length of internal threads shall not be less than the effective thread length, L_2 , of the external thread as specified in the figure belonging to Table D.29/Table E.29 and Table D.30/Table E.30 and as stipulated in API 5B.
- b) Internal and external NPT threads meeting the requirements of ASME B1.20.1.

NOTE 1 Pipe threads, general-purpose (inch), may be used for line pipe thread sizes 38 mm (1½ in.) and smaller.

NOTE 2 Although line pipe threads in accordance with API 5B and NPT threads are basically interchangeable, the slight variation in thread form can increase wear and tendency for galling after several make-ups.

14.3.2.2 Thread Clearance

A clearance of minimum length, J , as illustrated in API 5B, shall be provided on all internal threaded equipment.

14.3.2.3 Thread Counterbores

End and outlet connectors, equipped with internal threads, may be supplied with or without a thread-entrance counterbore. Internal threads, furnished without a counterbore, should have the outer angles of 45° to a minimum depth of $P/2$, as illustrated in the figure belonging to Table D.29/Table E.29 and Table D.30/Table E.30. Internal threads, furnished with a counterbore, should conform to the counterbore dimensions specified in Table D.29/Table E.29 and Table D.30/Table E.30 and the bottom of the counterbore should be chamfered at an angle of 45° .

NOTE As an alternative, counterbore dimensions may be as specified in API 5B.

14.3.2.4 Thread Alignment

Threads shall align with the axis of the end connector within a tolerance of ± 5.0 mm/m (± 0.06 in./ft) or 0.3° of the projected axis.

14.3.2.5 End/Outlet Coupling Diameter

The outlet coupling diameter shall be of sufficient diameter to provide for the structural integrity of the threaded part at the rated working pressure. This diameter shall not be less than the tabulated joint or coupling diameter for the specified thread.

14.3.3 Materials

Material requirements for threaded connectors shall conform to the requirements in Section 6.

14.3.4 Quality Control/Testing

Threaded connectors shall meet the applicable requirements of 10.4.2.

14.3.5 Marking

Threaded connectors shall be marked as specified in 12.5 and 12.6.

14.3.6 Storing and Shipping

Threaded connectors shall be stored and shipped in accordance with Section 13.

14.4 Tees and Crosses

14.4.1 General

NOTE Requirements for tees and crosses are given in 14.4.

14.4.2 Design

14.4.2.1 Nominal Size and Pressure Rating

Nominal sizes and pressure ratings for tees and crosses shall be as specified in Table D.13/Table E.13 and Table D.14/Table E.14, with the following exception: oversize entrance bores of 81 mm [+0.8/0 mm] and 108 mm [+0.8/0 mm] ($3\frac{3}{16}$ in. [+0.03/0 in.] and $4\frac{1}{4}$ in. [+0.03/0 in.]) are allowable for 79 mm and 103 mm ($3\frac{1}{8}$ in. and $4\frac{1}{16}$ in.) nominal sizes for rated working pressures of 13.8 MPa; 20.7 MPa and 34.5 MPa (2000 psi; 3000 psi and 5000 psi) for use with valves with oversize bores as listed in Table D.22/Table E.22 and Table D.23/Table E.23.

14.4.2.2 End Connectors

All end connectors shall conform to 14.1 or 14.9.

14.4.2.3 Dimensions

Bore and center-to-face dimensions shall conform to those shown in Table D.13/Table E.13 and Table D.14/Table E.14.

14.4.3 Materials

Materials for tees and crosses shall conform to Section 6.

14.4.4 Quality Control/Testing

Tees and crosses shall successfully complete the tests required and described in Section 11.

14.4.5 Marking

Tees and crosses shall be marked as specified in Section 12 and Table 40.

Table 40—Marking for Tees and Crosses

Required Markings	Required Location(s)
API 6A or 6A Temperature class(es) or ratings Material class Product specification level (PSL) Date of manufacture Manufacturer's name or mark Serial number (if applicable)	Nameplate and/or body
Bore size (if applicable) End and outlet connector size Rated working pressure	Nameplate and/or body and outside diameter of each connector
Ring groove type and number	Near each connector or thread
Hardness test values (if applicable) (see 12.8)	Adjacent to test location
FOOTNOTE Performance requirement marking is not required for tees and crosses.	

14.4.6 Storing and Shipping

Tees and crosses shall be stored and shipped in accordance with Section 13.

14.5 Bullplugs

14.5.1 General

Bullplugs shall meet the applicable requirements specified for loose connectors.

14.5.2 Design

14.5.2.1 General

The materials and design of bullplugs and threaded connectors shall be considered in determining the working pressure and external load capacity.

14.5.2.2 Dimensions

Bullplugs shall conform to the dimensions and tolerances in Table D.15/Table E.15. Threaded connectors shall conform to 14.3.

This specification shall apply to bullplugs 1/2 in. line pipe or NPT size and larger up to 4 in. line pipe size.

NOTE Other sizes are outside the scope of this specification.

14.5.2.3 Rated Working Pressure

The rated working pressure for bullplugs with line pipe or NPT threads 1/2 in. to 4 in. shall be as specified in Table 1.

NOTE Bullplugs of stronger materials, larger thread dimensions and/or larger designs that are rated for higher working pressures are outside the scope of this specification.

14.5.2.4 Thread Engagement

Threaded connectors shall conform to 14.3. Bullplugs with API 5B line pipe threads shall be assembled with mating parts in conformance with Table 41. Thread compounds tested in accordance with API 5A3 shall be used.

Table 41—Recommended Bullplug Installation Procedure

Size in.	Minimum Recommended Turns Past Hand-tight Condition ^a
1/2, 3/4, and 1	1 1/2
2 through 4	2
FOOTNOTES Thread compounds shall be in serviceable condition to provide leak-free performance. ^a Recommended turns past hand-tight is normally sufficient to contain rated working pressure and test pressures up to 103.5 MPa. However, retightening up to an additional one or two turns may be required in some cases.	

14.5.3 Materials

Bullplug material shall, as a minimum, meet the requirements of 6.2, PSL 3 and 6.3, PSL 3. Material shall be in accordance with material designation 60K for 13.8 MPa (2000 psi) to 69.0 MPa (10,000 psi) rated working pressure. Bullplugs shall be material class DD, FF, or HH.

14.5.4 Quality Control/Testing

14.5.4.1 General

Bullplugs shall meet the requirements of 10.4.10.

NOTE PSLs are not applicable to bullplugs.

14.5.4.2 Coating

Bullplug threads shall be coated to minimize galling and develop maximum leak resistance. The threads shall be gauged after coating.

14.5.5 Marking

Bullplugs shall be marked with “API 6A” or “6A” followed by the nominal size, material class, and manufacturer’s name or mark, as a minimum.

NOTE 1 Bullplugs may be marked on the exposed end or on the flat of the hex, as applicable.

NOTE 2 Bullplugs with an internal hex may be marked on the smaller, nonexposed hex.

14.5.6 Storing and Shipping

Bullplugs shall be stored and shipped in accordance with Section 13.

14.6 Valve-removal Plugs

14.6.1 General

NOTE 1 Valve-removal preparations and valve-removal plugs are specified in 14.6.

NOTE 2 Valve-removal plugs in this specification are not designed for use with test and blind flanges manufactured with the standard dimensions of 14.1.

NOTE 3 High-pressure valve removal (HPVR) preparations may be used for all working pressure outlets.

14.6.2 Design

14.6.2.1 General

The VR design shall not be used for outlets rated above 69.0 MPa (10,000 psi).

The HPVR design shall not be used for outlets rated above 138.0 MPa (20,000 psi).

Internal pressure-relief check valves, internal threaded connectors, and other internal devices shall be permitted for valve-removal plugs but are not specified in this specification.

14.6.2.2 Dimensions

VR preparation dimensions shall be in accordance with Table D.17/Table E.17. Included thread taper for all sizes shall be 1-in-16 on the diameter (reference 1° 47′ 24″ with the centerline).

VR plug dimensions shall be in accordance with Table D.16/Table E.16. Included thread taper for all sizes shall be 1-in-16 on the diameter (reference 1° 47′ 24″ with the centerline).

HPVR preparation dimensions shall be in accordance with Table D.21/Table E.21.

HPVR plug dimensions shall be in accordance with Table D.20/Table E.20.

HPVR plug thread form dimensions shall be in accordance with Table D.20/Table E.20. All diameters shall be concentric within 0.13 mm (0.005 in.) total indicator reading. HPVR plug thread form dimensions shall be Stub Acme in accordance with ASME B1.8.

14.6.3 Materials

Valve-removal-plug body material shall, as a minimum, meet PSL 3 material requirements of 6.2 and 6.3. Material shall be in accordance with material designation 60K for VR plugs and 75K for HPVR plugs. Valve-removal plugs shall be material class DD, FF, or HH.

The materials for VR and HPVR preparations shall meet the material designations for flanged integral end connectors in Table 7.

14.6.4 Quality Control/Thread Gauging

14.6.4.1 Thread Gauging

VR plugs and plug preparations shall be dimensionally inspected.

NOTE 1 VR plug preparations may be inspected in accordance with Table D.19/Table E.19.

NOTE 2 VR plugs may be inspected in accordance with Table D.18/Table E.18.

HPVR plugs and plug preparations shall be dimensionally inspected. Inspection methods shall be in accordance with the manufacturer's documented procedures.

14.6.4.2 Coating

VR plug threads shall be coated to minimize galling and develop maximum leak resistance. The threads shall be gauged after coating.

14.6.4.3 Quality Control

Valve-removal plugs shall meet the requirements of 10.4.10.

NOTE 1 PSLs are not applicable to valve-removal plugs.

NOTE 2 This specification does not require pressure testing for valve-removal preparations and valve-removal plugs.

14.6.5 Marking

Valve-removal plugs shall be marked with "API 6A" or "6A" followed by the nominal size and "VR" for 69.0 MPa (10,000 psi) working pressure or "HPVR" for 138.0 MPa (20,000 psi) working pressure, material class, and manufacturer's name or mark, as a minimum.

14.6.6 Storing and Shipping

Valve-removal plugs shall be stored and shipped in accordance with Section 13.

14.7 Top Connectors

14.7.1 General

NOTE 1 Top connectors that provide access to the tree bore are covered in 14.7.

Lift threads in top connectors are not designed for pressure containment and shall be used for lifting purposes only.

NOTE 2 This specification is not applicable to these lift threads.

14.7.2 Design

14.7.2.1 General

Top connectors shall be designed to satisfy the service conditions specified in 4.3.

Top connectors shall be designed to satisfy the requirements of 5.1.3 and 5.1.4.

Top connectors shall conform to the requirements of 5.3, 5.4, and 5.5.

A means shall be provided such that any pressure underneath the top connector can be vented prior to top connector release.

14.7.2.2 Dimensions

Top connectors that use end connectors as specified in this specification shall conform to the requirements of 14.1, 14.2, and 14.3.

Top connectors that use OECs shall conform to the requirements of 14.9.

NOTE For a recommended standard design of top connector parts and assemblies, see Annex K.

14.7.3 Materials

Pressure-containing parts of the top connector that come into contact with internal fluids shall conform to all the requirements of Section 6.

Structural and sealing members of the top connector, such as caps, collars, hammer nuts, clamps, and bolting, shall meet the manufacturer's written specification in accordance with 6.2.

14.7.4 Quality Control/Testing/Welding

14.7.4.1 Welding

Any welding performed on the pressure-containing parts of the top connector shall conform to the requirements of 7.3 and 7.4.

Any welding performed on the structural members of the top connector shall conform to the requirements of 7.2.

14.7.4.2 Quality Control

Quality control requirements for pressure-containing parts of the top connector (e.g. bodies and blanking plugs) shall conform to the requirements of 10.4.2.

Quality control requirements for structural members of the top connector members (e.g. bonnet nuts, clamps, and other load-bearing parts) shall conform to the applicable requirements of ASTM A370, ASTM E10, and ASTM E18 for the following:

- tensile testing;
- impact testing;
- hardness testing.

Acceptance criteria shall be in conformance with the manufacturer's material specification.

Quality control requirements for chemical composition analysis and dimensional inspection shall be in conformance with the manufacturer's material specification and other documented design requirements.

Quality control for closure bolting shall conform to 8.3.

Quality control for nonintegral metal seals shall conform to 10.4.5.

Quality control for nonmetallic seals shall conform to 10.4.6.

14.7.4.3 Testing

Top connector assemblies shall be tested in accordance with Section 11 (see Table 33).

14.7.5 Marking

Top connectors shall be marked as specified in Section 12 and Table 42.

14.7.6 Storage and Shipping

Top connectors shall be stored and shipped in accordance with the requirements of Section 13.

14.8 Crossover Connectors

14.8.1 General

Crossover connector types shall include crossover spools, multistage crossover spools, crossover adapters, and crossover tubing-head adapters.

Table 42—Marking for Top Connectors

Required Markings	Required Location(s)
API 6A or 6A Temperature class(es) or ratings Material class Product specification level (PSL) Date of manufacture Manufacturer's name or mark Serial number (if applicable) Minimum vertical bore	Nameplate and/or body
Nominal bore size (if applicable) End and outlet connector size Rated working pressure Ring groove type and number (if applicable)	Nameplate and/or body and outside diameter of connector
Thread size (threaded products only)	Nameplate and/or body or near thread
Hardness test values (if applicable) (see 12.8)	Adjacent to test location
FOOTNOTE Performance requirement marking is not required for top connectors.	

Crossover connectors shall meet the requirements of 14.14 for tubing-head adapters.

The following shall apply.

- a) Crossover spool: A crossover spool shall suspend and seal around a string of casing or tubing and shall be identified as either a casing spool or a tubing spool. The spool shall contain a restricted-area sealing means at or near the face of the lower connector, permitting a pressure rating greater than the pressure rating of the lower connector in the section above the restricted-area sealing means (see Figure 7 and Figure 8 for examples of crossover spools).
- b) Multistage crossover spool: A multiple stage crossover spool shall suspend and seal around multiple strings of casing and/or tubing. The multistage crossover spool shall contain a restricted-area sealing means at each stage, permitting an increase of one or more pressure ratings greater than the stage or connector immediately below. The upper connector shall be at least one pressure rating greater than the lower connector (see Figure 9 for an example of a multistage crossover spool).
- c) Crossover adapter: A crossover adapter shall be used between two casing spools, or between casing and tubing spools, to allow an increase in pressure rating between the spools (see Figure 10 for an example of a crossover adapter).
- d) Crossover tubing-head adapter: A crossover tubing-head adapter shall be used between a tree and the tubing head to allow an increase in pressure rating between the two (see 14.14).

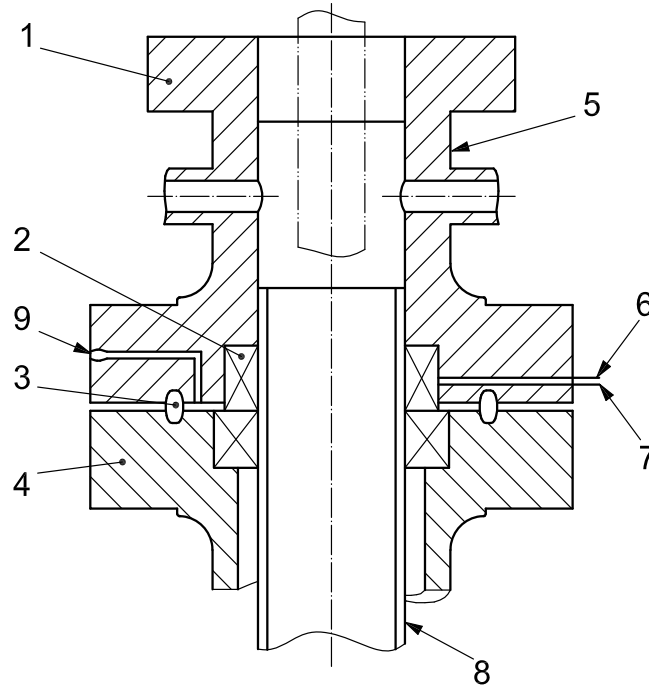

Key

- | | | |
|--------------------------------|-------------------------|-------------------------|
| 1 upper connector of the spool | 4 lower connector | 7 lower-pressure rating |
| 2 restricted-area packoff | 5 spool | 8 inner casing |
| 3 ring gasket | 6 upper-pressure rating | 9 test port |

Figure 7—Crossover Spool with Restricted-area Packoff Supported by the Lower Head

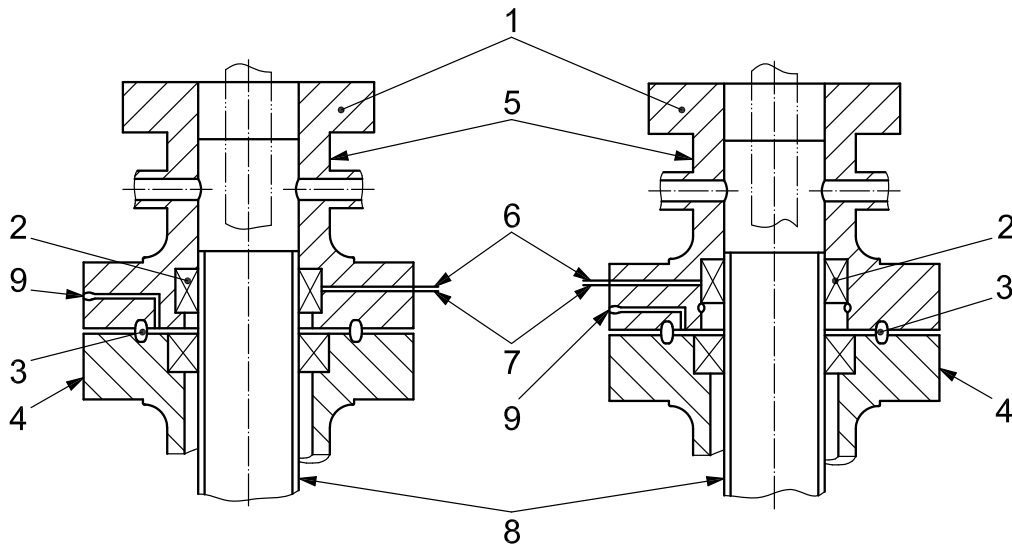

Key

- | | | |
|--------------------------------|-------------------------|-------------------------|
| 1 upper connector of the spool | 4 lower connector | 7 lower-pressure rating |
| 2 restricted-area packoff | 5 spool | 8 inner casing |
| 3 ring gasket | 6 upper-pressure rating | 9 test port |

Figure 8—Crossover Spool with Restricted-area Packoff Supported by the Upper Spool

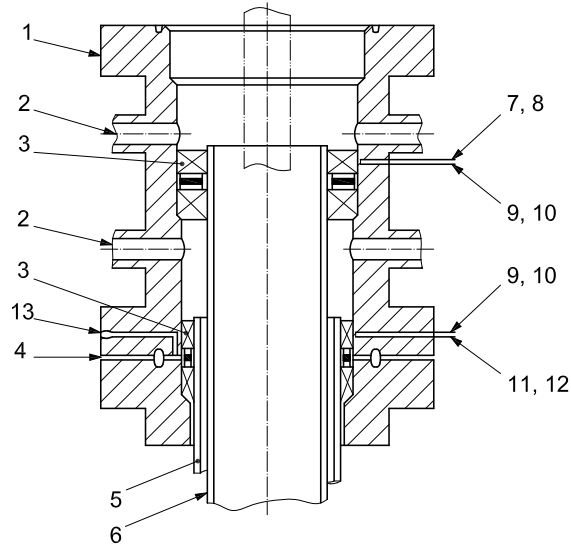

Key

- | | |
|--------------------------------|---------------------------------|
| 1 upper connector of the spool | 7 stage 3 |
| 2 outlet | 8 higher-pressure rating |
| 3 restricted-area packoff | 9 stage 2 |
| 4 lower connector | 10 intermediate pressure rating |
| 5 inner string 1 | 11 stage 1 |
| 6 inner string 2 | 12 lower-pressure rating |
| | 13 test port |

Figure 9—Multistage Crossover Spool

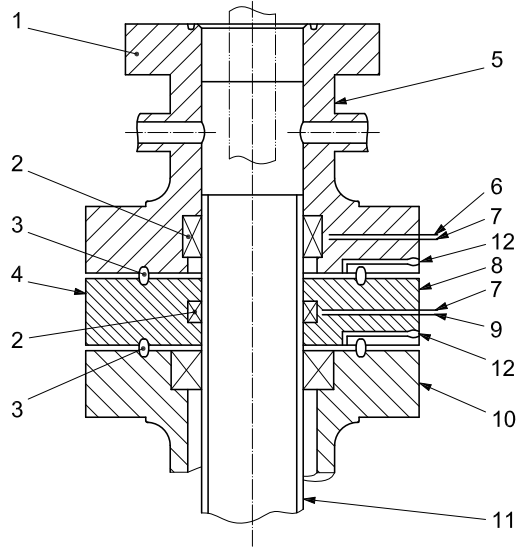

Key

- | | |
|--------------------------------|--------------------------|
| 1 upper connector of the spool | 7 second pressure rating |
| 2 restricted-area packoff | 8 crossover |
| 3 ring gasket | 9 lower-pressure rating |
| 4 second connector | 10 lower connector |
| 5 spool | 11 inner casing |
| 6 upper-pressure rating | 12 test port |

Figure 10—Crossover Adapter

14.8.2 Design

14.8.2.1 Performance Requirements

Crossover connectors shall be designed to be used in an assembly as illustrated in Figure 7, Figure 8, Figure 9, or Figure 10.

Crossover connectors shall meet the general requirements of 4.2 and shall be capable of performing as outlined in Table 43.

Table 43—Performance Requirements for Crossover Connectors

Performance Requirement Level	Pressure Integrity ^a
PR1	1 cycle
PR2	3 cycles
FOOTNOTE	
^a Shall seal rated working pressure internally.	

14.8.2.2 End Connectors

End connectors shall conform to the requirements of 14.1, 14.3, or 14.9.

The upper connector of a crossover spool shall be at least one pressure rating above the lower connector.

14.8.2.3 Rated Working Pressure—Body

The section of the body above the restricted-area packoff of a crossover connector shall be designed to sustain the rated working pressure of the upper connector. Sections below the restricted-area packoff shall be designed to sustain the working pressure of that section plus any pressure-induced loads resulting from the upper pressure acting on the restricted-area packoff.

The restricted-area packoff and its retention means shall be designed so that the pressure-induced loads transferred from containment of the full working pressure by the upper connector and/or any upper stage do not exceed the requirements of 5.1.3 at any part of the body or lower connector.

14.8.2.4 Restricted-area Packoffs

Each crossover spool, multistage crossover spool, crossover adapter, and crossover tubing-head adapter shall have at least one restricted-area packoff. Restricted-area packoffs to seal on casing or tubing shall be designed to accommodate the outside-diameter pipe tolerances.

For casing or tubing sizes defined by API 5CT, the tolerances in API 5CT shall apply. For sizes not covered by API 5CT, the tolerances shall be per an industry standard used (for example, API 5L).

NOTE The tolerances of casing and tubing outside diameters vary substantially between the various editions of API 5CT. In general, the tolerance has increased over time; this can affect equipment interchangeability.

14.8.2.5 Crossover Connectors and Restricted-area Packoffs

Crossover connectors and restricted-area packoffs shall be designed to conform to 5.1.3.

14.8.2.6 Test, Vent, Gauge, and Injection Connectors

Test, vent, gauge, and injection connectors, located above the restricted-area packoff in crossover connectors, shall have a pressure rating equal to or greater than the highest rated working pressure.

14.8.3 Materials

Pressure-containing parts that come into contact with internal fluids shall conform to the requirements of Section 6.

Structural and sealing members shall meet the manufacturer's written specification in accordance with 6.2.

14.8.4 Quality Control/Testing

Crossover connectors shall successfully complete the testing required and described in Section 11.

14.8.5 Marking

Crossover connectors shall be marked as specified in Section 12 and Table 44.

Table 44—Marking for Crossover Connectors

Required Markings	Required Location(s)
API 6A or 6A Temperature class(es) or ratings Material class Product specification level (PSL) Performance requirement (PR) Date of manufacture Manufacturer's name or mark Serial number (if applicable)	Nameplate and/or body
Nominal bore size (if applicable) End and outlet connector size Rated working pressure	Nameplate and/or body and outside diameter of connector
Thread size (threaded products only)	Nameplate, body, or near thread
Ring groove type and number	Near each connector or thread
Hardness test values (if applicable) (see 12.8)	Adjacent to test location

14.8.6 Storing and Shipping

All crossover connectors shall be stored and shipped in accordance with Section 13.

14.9 Other End Connectors

14.9.1 General

NOTE OECs that may be used for joining pressure-containing or pressure-controlling equipment and whose dimensions are not specified in this specification are covered in 14.9.

14.9.2 Design

14.9.2.1 General

OECs shall be capable of performing as outlined in Table 45.

Table 45—Performance Requirements for Other End Connectors

Performance Requirement Level	Pressure Integrity ^a	Bending Moments	Make-and-break
PR1	1 cycle	b	c
PR2	3 cycles	b	c
FOOTNOTES ^a Shall seal rated working pressure internally. ^b Shall withstand manufacturer's rated bending moments, if applicable. ^c Shall withstand manufacturer's make-and-break cycles, if applicable.			

14.9.2.2 Nominal Size and Pressure Rating

OECs shall be designed with the same nominal sizes and pressure ratings shown in 14.1 or, if appropriate, the sizes shown in 14.3.

14.9.2.3 Dimensions

No dimensional requirements for OECs shall apply except as in 14.9.2.2.

14.9.3 Materials

OEC materials shall meet the requirements of Section 6.

14.9.4 Quality Control/Testing

Equipment that uses OECs shall successfully complete the tests required in Section 11 and the appropriate subsection of Section 14.

NOTE Hydrostatic testing is not required for loose OECs.

14.9.5 Marking

OECs shall be marked with the size and/or pressure rating followed by "OEC."

14.9.6 Storing and Shipping

OECs shall be stored and shipped in accordance with Section 13.

14.10 Spools (Adapter and Spacer)**14.10.1 General**

NOTE Adapter spools and spacer spools are wellhead sections that have no provision for suspension of tubular members and that can have no provision for sealing of tubular members.

Spacer spools shall have end connectors of the same size, rated working pressure, and design.

Adapter spools shall have end connectors of different sizes, pressure ratings, and/or designs.

14.10.2 Design**14.10.2.1 Rated Working Pressure**

The rated working pressure of the adapter or spacer spool shall be the lowest rating of the end and outlet connectors on the adapter.

14.10.2.2 End and Outlet Connectors

NOTE End and outlet connectors may be flanged or studded in accordance with 14.1, threaded in accordance with 14.3, or have OECs in accordance with 14.9 or clamp hubs in accordance with API 16A.

14.10.3 Materials

Materials shall conform to Section 6.

14.10.4 Quality Control/Testing

All adapter and spacer spools shall pass the tests of Section 11.

14.10.5 Marking

Spools shall be marked as specified in Section 12 and Table 46.

Table 46—Marking for Spools

Required Markings	Required Location(s)
API 6A or 6A Temperature class(es) or ratings Material class Product specification level (PSL) Date of manufacture Manufacturer's name or mark Serial number (if applicable)	Nameplate and/or body
Nominal bore size (if applicable) End and outlet connector size Rated working pressure	Nameplate and/or body and outside diameter of connector
Thread size (threaded products only)	Nameplate, body, or near thread
Ring groove type and number	Near each connector or thread
Hardness test values (if applicable) (see 12.8)	Adjacent to test location
FOOTNOTE Performance requirement marking is not required for spools.	

14.10.6 Storing and Shipping

All adapter and spacer spools shall be stored and shipped in accordance with Section 13.

14.11 Valves

14.11.1 General

14.11.1.1 Single Valves

Valves, including actuated shutoff and check valves, and valves with rated working pressures equal to and greater than 13.8 MPa (2000 psi), shall satisfy the requirements stipulated in 14.11.2 to 14.11.6. Valves shall meet all the requirements of Section 4 and Section 5.

NOTE 1 Valves may be used for well control, flowline control, repressuring, and cycling services.

NOTE 2 Safety valves are addressed in 14.17.

14.11.1.2 Multiple Valves

Multiple valves shall satisfy the requirements stipulated in 14.11.2 to 14.11.6. Multiple valves shall meet all the requirements of Section 4 and Section 5.

Multiple valves shall be full-bore, gate, ball, or plug valves that have two or more valves in a single unitized body. Multiple valves shall be a composite arrangement of valves covered by 14.11.2.

Multiple-string valves shall have dual, triple, quadruple, and quintuple parallel bores terminating in single or multiple connectors at each end.

NOTE 1 Multiple valves may incorporate outlet bores and outlet connectors in addition to the end connectors and may include integral wing valves in the outlet bores. Outlet bores are typically at 90° or 45° with respect to the main conduit bores.

Multiple valves shall meet all the design requirements of valves in 14.11.2, unless otherwise indicated.

NOTE 2 An example of a multiple valve configuration is shown in Figure 11.

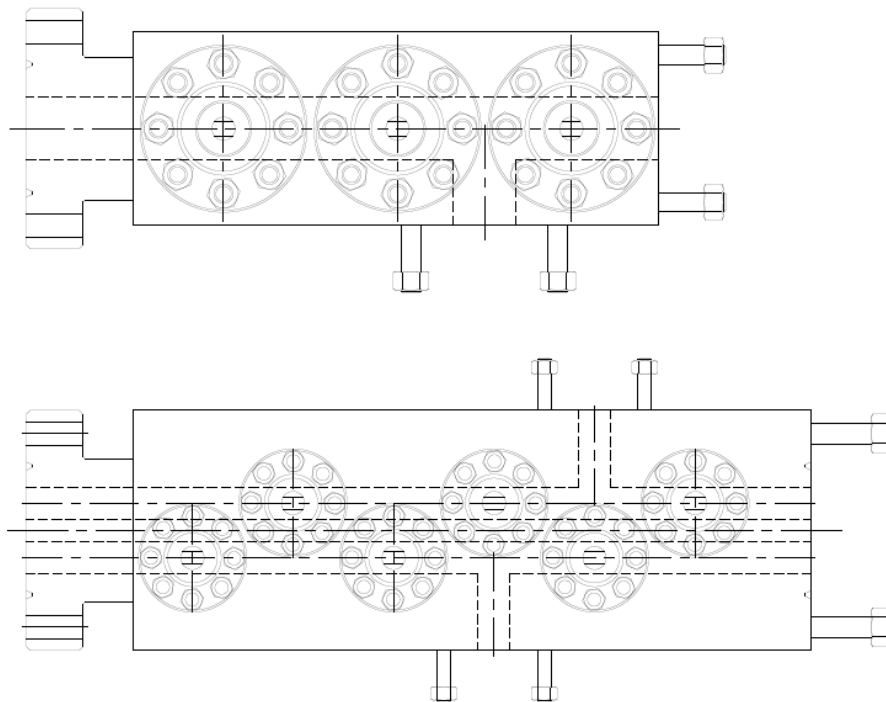

Figure 11—Single-string and Dual-string Multiple Valve Assemblies

14.11.1.3 Actuated Valves

Actuated valves shall be provided with an actuator to automatically open or close the valve.

NOTE 1 Actuated valves can be flanged, threaded, or other end-connected, full-bore or reduced-opening, gate valves, plug type valves, or ball type valves.

NOTE 2 Actuator specifications are contained in 14.16.

14.11.1.4 Valves Prepared for Actuators

Valves, including multiple, prepared for actuators shall include all parts required to properly function when assembled with the actuator. The valve bonnet assembly, including associated parts, such as stem and seals, shall be part of either the valve or actuator. The valve prepared for actuator, if assembled with the actuator, shall meet all the requirements of actuated valves.

14.11.1.5 Check Valves

Check valves shall be of the swing and lift check types.

NOTE 1 The valves may be full-opening or reduced-opening and are used to permit fluid flow in only one direction.

NOTE 2 Check valves may be furnished in the following types:

- regular swing check (see Figure 12);
- full-opening swing check (see Figure 13);
- regular lift check (see Figure 14).

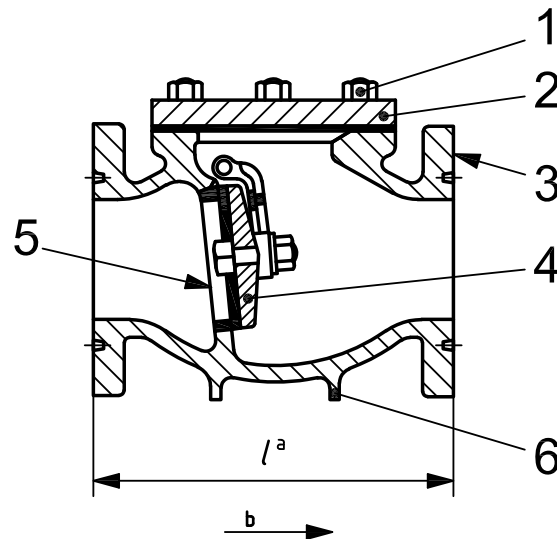

Key

1 cover closure bolting	4 disc
2 cover	5 seat ring
3 body	6 support ribs or legs

^a Face-to-face dimension.

^b Direction of flow.

Figure 12—Regular Swing Check Valve

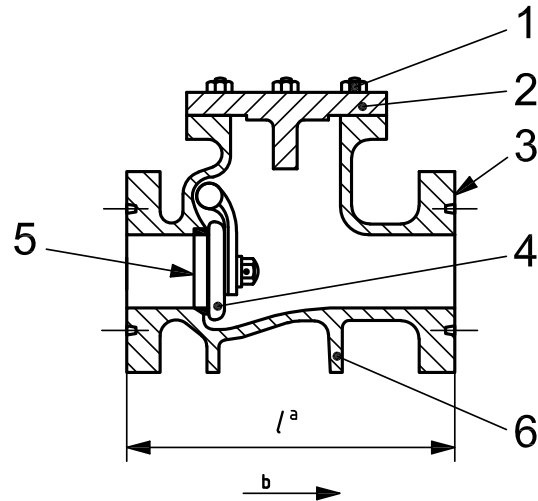

- Key**
- | | |
|-------------------------|------------------------|
| 1 cover closure bolting | 4 disc |
| 2 cover | 5 seat ring |
| 3 body | 6 support ribs or legs |
- ^a Face-to-face dimension.
^b Direction of flow.

Figure 13—Full-opening Swing Check Valve

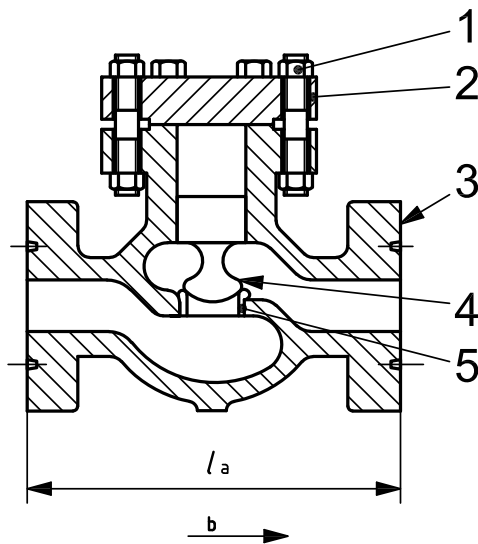

- Key**
- | | |
|-------------------------|-------------|
| 1 cover closure bolting | 4 piston |
| 2 cover | 5 seat ring |
| 3 body | |
- ^a Face-to-face dimension.
^b Direction of flow.

Figure 14—Regular Lift Check Valve

14.11.2 Design

14.11.2.1 Performance Requirements

Valves shall meet the general performance requirements of 4.2 when operating as indicated in Table 47. This includes manually actuated valves and valves designed for actuators.

Table 47—Operating Cycle Requirements for Valves

Performance Requirement Level	Operating Cycles
PR1	3 cycles
PR2	200 cycles

14.11.2.2 Dimensions

14.11.2.2.1 Single Valves

The following shall apply.

- a) Nominal size: Valves shall be identified by the nominal valve size in Table D.22/Table E.22 and Table D.23/Table E.23.
- b) Face-to-face dimensions.
 - 1) General: The face-to-face dimension shall be defined as the longest overall distance measured on the horizontal centerline of the valve between machined surfaces.
 - 2) Flanged valves: Flanged face-to-face dimensions shall correspond to the dimensions shown in Table D.22/Table E.22 and Table D.23/Table E.23, as applicable.

Face-to-face dimensions not listed in the tables shall be per manufacturer requirements.
 - 3) Valves with studded connector or OEC: There are no requirements for the face-to-face dimensions of valves with OECs or with studded connectors.
 - 4) Reduced-opening gate valve: There are no requirements for face-to-face dimensions of reduced-opening gate valves.
- c) Full-bore valves: All full-bore valves shall have round passageways (bores) through the bodies, seats, gates or plugs, and end connectors. Body bore diameter shall conform to the bore dimensions given in Table D.22/Table E.22 and Table D.23/Table E.23. The bore diameter of seats, gates, plugs, or other related internal parts shall have the same dimensions or larger.

14.11.2.2.2 Multiple Valves

The following shall apply.

- a) Valve size: Table D.25/Table E.25 and Table D.26/Table E.26 specify the maximum valve size for a given bore center-to-center, or flange center to bore center. Smaller nominal-sized valves may be furnished on the specified center-to-center. The flange shown is the minimum required for a specified center-to-center. A larger flange may be used.

b) End-to-end dimensions:

NOTE There are no end-to-end dimension requirements for multiple valves.

c) Bore locations: Dimensions shall be measured from end-connector center.

Based on the centerline of the end connectors, the several bores of the multiple valve shall be located according to Table D.25/Table E.25 and Table D.26/Table E.26.

14.11.2.2.3 Actuated Valves

Valves shall meet the requirements of 14.11.2.2.1. Actuators shall meet the requirements of 14.16.2.

NOTE A provision for relief of pressure build-up may be included in the valve bonnet assembly (and associated parts) as part of either the valve or actuator.

14.11.2.2.4 Valves Prepared for Actuators

Valves prepared for actuators shall meet the applicable requirements for actuated valves.

14.11.2.2.5 Check Valves

The following shall apply.

- a) Nominal size: Check valves shall be identified by the nominal valve size in column 1 of Table D.24/Table E.24.
- b) Face-to-face dimension: The face-to-face dimension for flanged end check valves shall correspond to the dimensions shown in Table D.24/Table E.24.
- c) Bores, of the following types.
 - Full-opening: All full-opening valves shall have round passageways through the body and seats. Bore diameter shall conform to the bore dimensions given in Table D.24/Table E.24.
 - Reduced-opening:

NOTE Regular-lift and swing check valves are customarily made with reduced bores through the seat and are sized at the option of the manufacturer.

14.11.2.3 Flanged End and Outlet Connectors

Valve end flanges shall conform to the requirements of 14.1.

Studded end connectors shall conform to the requirements of 14.1.2.5.

For multiple-string valves, a pair of bolt holes in both end flanges shall straddle the common centerline. The individual bore seals used in end connectors of multiple-string valves shall be specified by the manufacturer.

NOTE End connectors of multiple valves may have a larger nominal size than the conduit bore(s). The bottom end connector size is typically determined by the nominal size of the tubing head or tubing-head adapter to which the lowermost tree valve is being attached.

14.11.2.4 Threaded End and Outlet Connectors

Threaded valves shall have line pipe, casing, or tubing threads conforming to 14.3.

Threaded valves shall be supplied only in sizes of 52 mm to 103 mm ($2\frac{1}{16}$ in. to $4\frac{1}{16}$ in.) and for rated working pressures of 13.8 MPa, 20.7 MPa, and 34.5 MPa (2000 psi; 3000 psi and 5000 psi) in accordance with 4.3.1.

14.11.2.5 Other End Connectors

OECs shall conform to the requirements of 14.9.

14.11.2.6 Stuffing Boxes

Open slots in glands or stuffing box flanges shall not be permitted.

14.11.2.7 Backseat

For gate valves, a backseat or other means for re-establishing a stem seal shall be provided.

14.11.2.8 Direction of Operation

Mechanically operated valves shall be turned in the anticlockwise direction to open and the clockwise direction to close.

14.11.2.9 Operating Mechanisms

Manually operated gate valves shall be supplied with a handwheel that permits opening and closing of the valve at the rated working pressure without the aid of tools or bars. Manually operated plug and ball valves shall be furnished with a wrench-operated (or bar-operated) mechanism or with a handwheel-actuated gear mechanism. All handwheels shall be replaceable while in service.

14.11.2.10 Operating Gears

Design of the geared operating mechanism shall permit opening and closing of the valve at the rated working pressure differential without aid of tools or bars.

14.11.2.11 Reduced-opening Valves

Manufacturers shall document flow characteristics and pressure drop for reduced-opening valves.

14.11.2.12 Test Port

For multiple string valves, the lower end connector shall have a test port extending from a point on the connector face between the bore seals and end connector seal to the outside diameter of the connector. This test port shall be as specified in 9.3.

14.11.3 Materials

14.11.3.1 Single, Multiple, and Check Valves

Single, multiple, and check valve materials for bodies, bonnets, end connectors, valve bore sealing mechanisms, and stems shall meet the requirements of Section 6.

14.11.3.2 Actuated Valves

Material for actuated valves shall meet the requirements of Section 6 or 14.16, as applicable.

14.11.3.3 Valves Prepared for Actuators

Valves prepared for actuators shall meet the requirements of 14.11.3.1.

14.11.4 Quality Control/Testing

14.11.4.1 Single Valves

14.11.4.1.1 Drift Test

All assembled full-bore valves shall pass a drift test as described in 11.4.

14.11.4.1.2 Acceptance Testing

All assembled valves shall successfully complete all applicable tests required and described in Section 11.

14.11.4.2 Multiple Valves

The requirements of 14.11.4.1 shall apply.

Additionally, each conduit bore of a multiple-string valve shall be drift tested.

14.11.4.3 Actuated Valves

Assembled actuated valves shall successfully complete all applicable tests required by and described in Section 11.

14.11.4.4 Valves Prepared for Actuators

Valves prepared for actuators shall successfully pass all applicable tests specified in Section 11. If a bonnet assembly is not included with the valve as a unit, backseat testing is not required, but shall be performed at assembly with the actuator.

NOTE Required testing may be performed using the test fixtures in lieu of the bonnet and actuator.

14.11.4.5 Check Valves

14.11.4.5.1 Drift Test

NOTE Check valves do not require a drift test.

14.11.4.5.2 Acceptance Testing

All assembled check valves shall successfully complete all applicable tests required and described in Section 11.

14.11.5 Marking

Valves, multiple valves, actuated valves, valves prepared for actuators, and check valves shall be marked as specified in Section 12 and Table 48.

Table 48—Marking for Valves

Required Markings	Required Location(s)
API 6A or 6A ^{a,b} Temperature class(es) or ratings Material class Product specification level (PSL) Performance requirements (PR) ^c Date of manufacture Manufacturer's name or mark Serial number (if applicable)	Nameplate and/or body
Rated working pressure Nominal bore size(s) ^d End and outlet connector size	Nameplate and/or body and outside diameter of each connector
Thread size (threaded products only)	Nameplate, body, or near thread
Ring groove type and number	Near each connector or thread
Flow direction (check and unidirectional valves only)	On body
Direction of movement to open	On handwheel
Hardness test values (if applicable) (see 12.8)	Adjacent to test location
FOOTNOTES ^a For valves prepared for actuators, mark the letter "V" after "API 6A" or "6A." ^b Valves that satisfy the requirements of API 6FA can be marked per the requirements therein in addition to the requirements of this section. ^c Allowable markings are PR1, PR2, or PR2F, as applicable. See 14.17.5 for SSV, USV, or BSDV. ^d For multiple-bore valves having unequal bore sizes, valves shall be designated by the nominal bore in decreasing sizes (e.g. 3 ¹ / ₁₆ x 2 ¹ / ₁₆ , 2 ⁹ / ₁₆ x 2 ¹ / ₁₆). For valves having equal bore sizes, valves shall be designated by the nominal bore size followed by the number of bores (e.g. 2 ¹ / ₁₆ quad) or by identifying all bore sizes (e.g. 2 ⁹ / ₁₆ x 2 ⁹ / ₁₆).	

Actuated valves shall be marked as specified in Section 12 and Table 49.

Table 49—Marking for Actuated Valves (Assemblies of Actuators with Valves Prepared for Actuators)

Required Markings	Required Location(s)
Date of final acceptance Name of manufacturer Location of manufacturer	Tag or nameplate

14.11.6 Storing and Shipping

All valves shall be stored and shipped in accordance with Section 13.

14.12 Back-pressure Valves

14.12.1 General

Back-pressure valves shall meet the applicable requirements of tubing hangers (see 14.13).

14.12.2 Design

Back-pressure valve design shall meet the manufacturer's specified requirements. Back-pressure valve shall have a feature to enable detection of internal pressure. An operating procedure for the back-pressure valve shall be furnished to the purchaser.

14.12.3 Materials

Body material shall, as a minimum, meet the applicable requirements of 14.13.3, PSL 3 tubing hangers. Material for other parts shall be in accordance with the manufacturer's written specifications.

14.12.4 Quality Control/Testing

Back-pressure valves shall meet the requirements of Section 10.4.10.

NOTE PSLs are not applicable to back-pressure valves.

14.12.5 Marking

Back-pressure valves shall be marked with "API 6A" or "6A" followed by the nominal size, working pressure, material class and manufacturer's name or mark, as a minimum.

14.12.6 Storing and Shipping

Storing and shipping shall be in accordance with Section 13.

14.13 Casing and Tubing Hangers (Slip- and Mandrel-type)

14.13.1 General

The following features shall apply.

- a) Group 1:
 - hangs pipe;
 - no annular seal.
- b) Group 2:
 - hangs pipe;
 - seals pressure from one direction.
- c) Group 3:
 - hangs pipe;
 - seals pressure from top and bottom with or without ring-joint isolation seal and downhole lines.
- d) Group 4:
 - same as group 3, with the hanger held in place by mechanical means applied to a retention feature;
 - retention of the hanger is independent of any subsequent member or wellhead part.
- e) Group 5:
 - same as group 4, with the hanger receiving back-pressure valve.

14.13.2 Design

14.13.2.1 Performance Requirements

14.13.2.1.1 General

The following shall apply.

- a) Group 1:
- shall be able to suspend manufacturer's rated load without collapsing the tubulars or hangers below drift diameter;
 - threaded connectors shall meet pressure-retaining requirements.
- b) Group 2:
- same as group 1 with the addition that the pressure load shall be considered with the hanging load.
- c) Group 3:
- same as group 2 with the addition that:
 - 1) all seals shall retain rated working pressure from either direction;
 - 2) if a crossover seal is included on the hanger, then it shall hold the higher rated working pressure from above;
 - 3) if downhole lines are included, they shall hold the rated working pressure of the hanger and any effects of the pressure load shall be included in the load rating.
- d) Group 4:
- same as group 3 with the addition that the minimum retention load capacity of the hanger's retention feature shall be equal to the force generated by the working pressure on the annular area.
- e) Group 5:
- same as group 3 with the addition that:
 - 1) minimum retention load capacity of the hanger's retention feature shall be equal to the force generated by the working pressure acting on the full area of the largest hanger seal;
 - 2) back-pressure valve preparations shall be capable of holding rated working pressure from below.

NOTE 1 The load and pressure ratings for casing and tubing hangers may be a function of the tubular grade of material and wall section as well as the wellhead equipment in which it is installed.

Manufacturers shall be responsible for supplying information about the load/pressure ratings of such hangers.

NOTE 2 Field test pressures may be different from the rated working pressure of a hanger due to casing-collapse restrictions or load-shoulder limits.

Nothing in 14.13.2.1.1 shall be interpreted as being a requirement for a wrap-around seal type tubing hanger.

14.13.2.1.2 Slip Hangers

The following shall apply.

- a) Load capacity: The load capacity for slip hangers shall meet the general requirements of 4.2 and slip hangers shall be capable of performing as outlined in Table 50.

Table 50—Performance Requirements for Slip Hangers

Performance Requirement Level	Load Capacity
PR1	1 cycle at minimum ^a rated load to maximum rated load
PR2	3 cycles at minimum ^a rated load to maximum rated load
FOOTNOTE	
^a Minimum rated load may be upward or compressive.	

- b) Temperature rating: The temperature rating of slip hangers shall be in accordance with 4.3.2.
- c) Performance requirements for group 1 slip hangers: Group 1 slip hangers shall meet the general requirements of 4.2 and shall be capable of performing as outlined in Table 50, except that they are not required to have pressure integrity.
- d) Performance requirements for group 2 slip hangers: Group 2 slip hangers shall meet the general requirements of 4.2 and shall be capable of performing as outlined in Table 50. They shall seal the rated working pressure in one direction across the annular seal at the rated load capacity for that pressure.
- e) Performance requirements for group 3 slip hangers: Group 3 slip hangers shall meet the general requirements of 4.2 and shall be capable of performing as outlined in Table 50. They shall seal the rated working pressure above and below the annular seal at the rated load capacity for that pressure. If a crossover packoff is included on the hanger, then it shall hold the higher rated working pressure from above. If downhole lines are included, they shall hold the rated working pressure of the hanger. Any effect of the pressure load shall be included in the load rating.
- f) Performance requirements for group 4 slip hangers: Group 4 slip hangers shall meet the general requirements of 4.2 and shall be capable of performing as outlined in Table 50. They shall seal the rated working pressure above and below the annular seal at the rated load capacity for that pressure. They shall also seal rated working pressure from below the annular seal while the hanger is retained in the bowl with the hanger retention feature. If a crossover packoff is included on the hanger, then it shall hold the higher rated working pressure from above. If downhole lines are included, they shall hold the rated working pressure of the hanger and any effect of the pressure load shall be included in the load rating.

14.13.2.1.3 Mandrel Hangers

The following shall apply.

- a) Load capacity: The load capacity for mandrel hangers shall meet the general requirements of 4.2 and mandrel hangers shall be capable of performing as outlined in Table 51. They shall seal the rated working pressure internally at the rated load capacity.

Table 51—Performance Requirements for Mandrel Hangers

Performance Requirement Level	Load Capacity
PR1	1 cycle at minimum ^a rated load to maximum rated load
PR2	3 cycles at minimum ^a rated load to maximum rated load
FOOTNOTE	
^a Minimum rated load may be upward or compressive.	

- b) Performance requirements for group 1 mandrel hangers: Group 1 mandrel hangers shall meet the general requirements of 4.2, except that they are not required to have pressure integrity.
- c) Performance requirements for group 2 mandrel hangers: Group 2 mandrel hangers shall meet the general requirements of 4.2. They shall seal the rated working pressure in one direction across the annular seal at the rated load capacity for that pressure.

- d) Performance requirements for group 3 mandrel hangers: Group 3 mandrel hangers shall meet the general requirements of 4.2. They shall seal the rated working pressure above and below the annular seal at the rated load capacity for that pressure. If a crossover packoff is included on the hanger, then it shall hold the higher rated working pressure from above. If downhole lines are included, they shall hold the rated working pressure from above and shall hold the rated working pressure of the hanger. Any effect of the pressure load shall be included in the load rating.
- e) Performance requirements for group 4 mandrel hangers: Group 4 mandrel hangers shall meet the general requirements of 4.2. They shall seal the rated working pressure above and below the annular seal at the rated load capacity for that pressure. They shall also seal the rated working pressure from below the annular seal while the hanger is retained in the bowl with the hanger retention feature. If a crossover packoff is included on the hanger, then it shall hold the higher rated working pressure from above. If downhole lines are included, they shall hold the rated working pressure of the hanger and any effect of the pressure load shall be included in the load rating.
- f) Performance requirements for group 5 mandrel hangers: Group 5 mandrel hangers shall meet the general requirements of 4.2. They shall seal the rated working pressure above and below the annular seal at the rated load capacity for that pressure. They shall also seal the rated working pressure from below with the ID of the hanger blanked off with no pipe suspended while the hanger is retained in the bowl with the hanger-retention feature. Back-pressure valve preparations shall be capable of holding rated working pressure from below. If a crossover packoff is included on the hanger, then it shall hold the higher rated working pressure from above. If downhole lines are included, they shall hold the rated working pressure of the hanger and any effect of the pressure load shall be included in the load rating.

14.13.2.2 Loads

The following loads shall be considered when designing any hanger:

- radial loads on hanger body due to tapered landing shoulder;
- tensile loads throughout hanger body due to weight of suspended tubulars;
- loads imparted to hanger due to field pressure test.

14.13.2.3 Threaded Connectors

Threads on threaded mandrel-type casing and tubing hangers shall be in accordance with 14.3. Other threaded connectors shall be in accordance with 14.9.

Material selection shall provide a joint strength in the hanger threads equal to, or greater than, that of the casing or tubing.

14.13.2.4 Maximum Diameter

The maximum outside diameter of any hanger that it is intended to run through a blowout preventer shall not exceed that shown in Table D.27/Table E.27.

14.13.2.5 Vertical Bore

The vertical through-bore of a tubing hanger shall provide full opening to the drift diameter of the suspended tubular or tree drift bar, whichever is smaller. Casing hangers shall be full-opening to the drift diameter of the suspended tubular. Back-pressure valve preparation shall also meet this through-bore requirement.

14.13.2.6 Rated Working Pressure

14.13.2.6.1 Slip-type Hangers

NOTE There is no requirement for slip hangers to have a pressure rating.

14.13.2.6.2 Mandrel-type Hangers

The following shall apply.

- a) With no extended seal neck: The rated working pressure for hanger body and primary seal shall be equal to the working pressure of the head in which it is landed, if no extended seal neck is provided.
- b) With extended seal neck: Maximum pressure rating for the hanger body and extended neck seal, if a crossover type seal is provided, shall be the working pressure of the next casing or tubing head or tubing-head adapter above the hanger.
- c) Limitation: Hangers can have a limitation on the pressure rating due to the pressure limitations of the threaded connectors.

14.13.2.7 Welds

The design of any weld shall be such that it satisfies all the design requirements of 14.13.2.

14.13.2.8 Pipe Dimensions

Slip-type hangers and sealing systems to seal on casing or tubing shall be designed to accommodate the outside diameter pipe tolerance.

For casing or tubing sizes defined by API 5CT, the tolerances in API 5CT shall apply. For sizes not covered by API 5CT, the tolerances shall be per an industry standard (for example, API 5L).

NOTE The tolerances of casing and tubing outside diameters vary substantially between the various editions of API 5CT. In general, the tolerance has increased over time; this can affect equipment interchangeability.

14.13.3 Materials

14.13.3.1 Slip-type Hangers

Materials for slip hangers shall be per the manufacturer's requirements.

14.13.3.2 Mandrel-type Hangers

14.13.3.2.1 General

All mandrel-type hangers shall be fabricated from wrought materials that meet the applicable property requirements specified by the manufacturer.

14.13.3.2.2 Processing

14.13.3.2.2.1 Hot Working Practices

All wrought materials shall be formed using hot working practices that produce a wrought structure throughout.

14.13.3.2.2.2 Melting Practices

The following requirements shall apply.

- a) For PSL 1, PSL 2, and PSL 3, the manufacturer shall specify the melting practices for all hanger mandrel materials.
- b) For PSL 4, the requirements shall be identical to those for PSL 1/PSL 2/PSL 3, with the addition that the manufacturer shall document the melting practice used for PSL 4 material.

14.13.3.2.3 Heat-treating

14.13.3.2.3.1 Equipment

All heat-treatment operations shall be performed utilizing equipment qualified in accordance with the requirements specified by the manufacturer. The requirements for heat-treating furnace calibration shall conform to 6.5 and Annex M.

14.13.3.2.3.2 Temperatures

The following requirements shall apply.

- a) For PSL 1, PSL 2, and PSL 3, time at temperature and thermal cycles shall conform to the manufacturer's heat-treatment specifications.
- b) For PSL 4, the requirements shall be identical to those for PSL 1 to PSL 3, with the addition that the temperature levels for PSL 4 parts shall be determined by using either a heat sink or contact thermocouple.

The heat sink shall be made of the same class of material when the parts are made of an alloy of the following classes: carbon steel, alloy steel, stainless steel, titanium-based alloys, nickel-copper alloys, and nickel-based alloys. For parts that do not meet one of the preceding classes, the heat sink shall be made from the same alloy as the part. The ER section of all heat sinks shall be determined in accordance with the methods of 6.4.2. The ER of the heat sink shall be greater than or equal to the largest ER of any part in a heat-treatment load.

NOTE As an alternative, a production part may serve as the heat sink, provided all the requirements of 6.3.4.2 PSL 4 are satisfied.

The temperature-sensing tip of the thermocouple shall be within the part or heat sink and be no closer than 25 mm (1 in.) to any external or internal surface.

14.13.3.2.3.3 Quenching (for Materials Quenched and Tempered)

The following requirements shall apply.

- a) Water quenching: The temperature of the water used to approximate the cooling rate of water shall not exceed 38 °C (100 °F) at the start of the quench. For bath-type quenching, the temperature of the water shall not exceed 49 °C (120 °F) at any time during the quench cycle.
- b) Other quenching media: The temperature range and control of the other quenching media shall meet the manufacturer's written specification.

NOTE See API 20H for recommendations for controls on quenching of batch heat-treatment loads.

14.13.3.2.4 Chemical Composition

Hanger mandrel materials shall conform to the manufacturer's written specification.

The manufacturer shall specify the nominal chemical composition, including the composition tolerances, of the material. Material composition shall be determined on a heat basis (or a remelt-ingot basis for remelt-grade materials) in accordance with a nationally or internationally recognized standard.

14.13.3.2.5 Material Qualification Testing Requirements

14.13.3.2.5.1 General

If minimum tensile and/or impact properties are required to qualify a material for service, the tests shall be performed as described in 6.3.2.2 and 6.3.2.3.

A QTC as described in 6.4 shall be used.

14.13.3.2.5.2 Tensile Testing

The following requirements shall apply.

- a) Test specimens: Tensile test specimens shall be removed from a QTC as described in 6.4.4.1.
- b) Test method: Perform tensile tests at a temperature between 4 °C and 50 °C (between 40 °F and 120 °F) in accordance with the procedures specified in ISO 6892-1 or ASTM A370.

Perform a minimum of one tensile test. The results of the tensile test(s) shall satisfy the manufacturer's specified requirements. The 0.2 % offset method shall be used for determination of the yield strength.

- c) Retesting: If the results of the tensile test(s) do not satisfy the applicable requirements, two additional tests from the required location within the same QTC with no additional heat-treatment may be performed to qualify the material. The results of each of these tests shall satisfy the applicable requirements.

14.13.3.2.5.3 Impact Testing

Impact requirements shall conform to the requirements for bodies, bonnets, and end and outlet connectors (see 6.3).

14.13.4 Quality Control/Testing

Hangers shall meet the quality control requirements of section 10.4.8 or 10.4.9, as applicable.

NOTE It is not a requirement of this specification to hydrostatically test hangers.

14.13.5 Marking

14.13.5.1 General

Hangers shall be marked in accordance with Section 12 and Table 52.

Table 52—Marking for Hangers

Marking	Location	
	Mandrel-type Hangers	Slip-type Hangers
API 6A or 6A Temperature class(es) or ratings Material class Product specification level (PSL) Performance requirements (PR) ^a Date of manufacture Manufacturer's name or mark Serial number (if applicable)	Nameplate and/or body	Nameplate and/or body
Minimum bore	Nameplate and/or body	—
Thread size	Nameplate, body, or near thread	—
Hardness test values (if applicable) (see 12.8)	Adjacent to test location	Adjacent to test location
Back-pressure valve style or model	Nameplate and/or body (tubing hangers only)	—
Bowl size and casing or tubing size	—	Nameplate and/or body
Rated working pressure (optional)	Nameplate and/or body	Nameplate and/or body
Load rating information (optional)	Nameplate and/or body	Nameplate and/or body
Minimum vertical bore	Nameplate and/or body	—
Orientation "DOWN" (if required)	Bottom of body	Bottom of body
FOOTNOTE ^a Allowable markings are PR1, PR2, or PR2F, as applicable.		

14.13.5.2 Marking of Mandrel Hangers

If mandrel hangers have different top and bottom threads, both threads shall be listed with the bottom thread first, followed by the top thread description plus the word "TOP." Any hanger that can be installed upside down shall have the word "DOWN" on the end that faces downhole when properly installed. Marking of rated working pressure and load rating is optional for mandrel hangers. Mandrel hangers shall be marked as specified in Table 52.

14.13.5.3 Marking of Slip Hangers

The slips in a slip hanger shall be sequentially marked if they are not interchangeable.

Any hanger that can be installed upside down shall have the word "DOWN" on the end that faces downhole when properly installed. Marking of rated working pressure and load rating is optional for slip hangers. Slip hangers shall be marked as specified in Table 52.

14.13.6 Storing and Shipping

Hangers shall be stored and shipped in accordance with Section 13.

The slips of a slip hanger shall be stored and shipped as a set.

14.14 Casing and Tubing Heads

14.14.1 General

The following shall apply.

- a) Casing-head housings and spools: Casing-head housings are attached to the upper end of the surface casing. Casing-head spools are attached to the top connector of housings or other spools. Both are designed to accept hanging and packing mechanisms that suspend and seal casing strings.
- b) Tubing-head spools: Tubing-head spools are attached to the top connector of casing-head housings or spools. Tubing-head spools are designed to accept packing mechanisms that seal casing strings and hanger and packing mechanisms that can be used to suspend and seal tubing strings.
- c) Tubing-head adapters: Tubing-head-to-master-valve adapters may be either integral with the master valve as its lower end connector or an independent piece of equipment. Configurations are dependent on the completion method being used. In addition to serving as adapters, they can also provide a means to connect and seal the tubing bore(s) to that of the master valve or to suspend the tubing string(s). Group 1 tubing-head adapters seal the well bore from the annulus. Group 2 tubing-head adapters seal the well bore from the annulus and suspend the tubing.

14.14.2 Design

14.14.2.1 Performance Requirements

The products mentioned in 14.14.1 a) and 14.14.1 b) with penetrations shall meet the requirements of 9.2 in addition to the requirements of 4.2.

For tubing-head adapters (see 14.14.2.10), the following shall apply.

- a) Performance requirements for group 1 tubing-head adapters: These products shall meet the general requirements of 4.2 and shall be capable of performing as outlined in Table 53.

Table 53—Performance Requirements for Group 1 Tubing-head Adapters

Performance Requirement Level	Pressure Integrity ^a
PR1	1 cycle
PR2	3 cycles
FOOTNOTE	
^a Capable of withstanding the rated working pressure internally.	

- b) Performance requirements for group 2 tubing-head adapters: These products shall meet the general requirements of 4.2 and shall be capable of performing as outlined in Table 54.

Table 54—Performance Requirements for Group 2 Tubing-head Adapters

Performance Requirement Level	Pressure Integrity ^a	Load Capacity ^b
PR1	1 cycle	1 cycle
PR2	3 cycles	3 cycles
FOOTNOTES		
^a Capable of withstanding the rated working pressure internally.		
^b At minimum rated load to maximum rated load.		

14.14.2.2 Loads

The following loads shall be considered when designing heads:

- hanging tubular loads;
- thermal tubular loads;
- pressure loads from blow-out-preventer testing and field pressure testing of hanger packing mechanisms;
- external axial and bending loads consistent with the capabilities of the end connectors on the heads.

14.14.2.3 End Connectors

The requirements in 14.1 for flanged or studded connectors shall apply to all head ends using flanged end connectors.

For casing-head housing with a threaded bottom connector, threaded bottom connectors for housings shall be threaded in accordance with 14.3.

OECs shall be in accordance with 14.9.

NOTE Housing-to-casing weld preparations are outside the scope of this specification.

14.14.2.4 Outlet Connectors

14.14.2.4.1 Pressure Rating

Pressure rating of outlet connectors shall be consistent with that of the upper end connector.

14.14.2.4.2 Flanged or Studded

Flanged or studded outlet connectors shall be in accordance with 14.1. Also, flanged or studded outlets 79 mm (3¹/₈ in.) and smaller shall be furnished with valve-removal plug preparation. Flanged or studded outlets 103 mm (4¹/₁₆ in.) or larger may be furnished with or without valve-removal plug preparation.

Valve-removal plug preparations shall be in accordance with 14.6.

14.14.2.4.3 API 5B Threaded

API 5B threaded outlets shall be in accordance with 14.3.

14.14.2.4.4 Other End Connectors

OECs shall be in accordance with 14.9.

14.14.2.5 Flange Counterbores

NOTE The provisions of this specification are not applicable to the diameter and depth of oversize counterbores intended to accept wear bushings and packer mechanisms.

If such counterbores are used in flanged or studded connectors, the manufacturer shall ensure that the oversize preparation does not cause the flange stresses to exceed the design criteria.

14.14.2.6 Vertical Bores

14.14.2.6.1 Full-opening Vertical Bore

In order to permit internal passage of tools or bottom hole equipment, the minimum vertical bore of wellhead bodies shall be 0.8 mm (0.03 in.) larger than the drift diameter Table D.28/Table E.28 of the largest casing over which the body is being used.

Wellhead bodies conforming to this requirement are referred to as having full-opening bores. The minimum vertical full-opening wellhead body bore, for the maximum casing size with which the bodies can be used, shall be as shown in Table D.28/Table E.28.

14.14.2.6.2 Reduced-opening Vertical Bore

The vertical bores specified in Table D.28/Table E.28 may be adapted to casing sizes smaller than those listed in the tabulation by suitable reducing threads, pilot rings, etc. The through-bore of these elements shall be 0.8 mm (0.03 in.) larger than the drift diameter of the casing over which the unit is used.

Typical illustrations of such adaptations are shown in Figure 15. Reduced vertical bores may also be supplied for weights of casing heavier than those listed in Table D.28/Table E.28. Reduced vertical bores for this application shall be 0.8 mm (0.03 in.) larger than the drift diameter of the heaviest wall casing over which it is being used.

14.14.2.6.3 Increased-opening Vertical Bore

In order to accept wear bushings and packer mechanisms, the vertical bore may be increased above the values in column 6 of Table D.28/Table E.28. However, it is the responsibility of the manufacturer to ensure that the oversize preparation does not cause the body stress to exceed the design criteria.

14.14.2.7 Rated Working Pressure

The rated working pressure of heads shall be in accordance with 4.3.1. Account shall be taken of the rated working pressure limitations for threaded connectors based on size and type of thread.

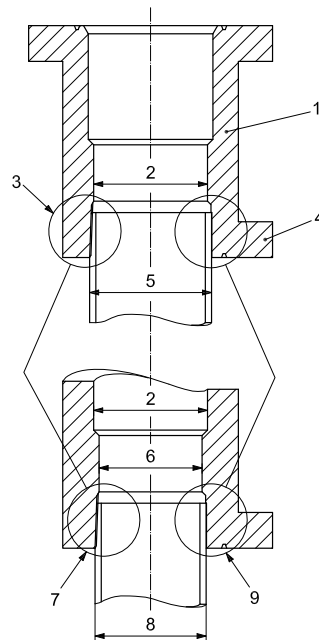

Key

- | | |
|--|------------------------------------|
| 1 wellhead body | 6 reduced full-opening bore |
| 2 regular full-opening bore | 7 casing thread |
| 3 threaded bottom connector | 8 smaller size casing |
| 4 bottom connector | 9 integral bore, adapter, or pilot |
| 5 maximum size casing (attached or beneath the body) | |

Figure 15—Typical Reduced-opening Vertical Bore

14.14.2.8 Test, Vent, Injection, and Gauge Connectors

14.14.2.8.1 General

Test, vent, injection, and gauge connectors shall be in accordance with 9.3.

14.14.2.8.2 Special Test Port

Casing-head spools and tubing-head spools with either a secondary seal or a crossover seal shall be provided with a test port in the lower connector.

14.14.2.8.3 Trapped Pressure

A means shall be provided such that any pressure behind a test, vent, injection, and gauge connector can be vented prior to opening the connection.

14.14.2.9 Crossover Spools

If casing-head spools or tubing-head spools are used as crossover spools, they shall satisfy the requirements of 14.8.

14.14.2.10 Tubing-head Adapters

14.14.2.10.1 Loads

The following loads shall be considered when designing tubing-head adapters:

- hanging and thermal tubular loads on adapters that incorporate hanger mechanisms;
- external axial and bending loads consistent with the capabilities of the end connectors.

14.14.2.10.2 End Connectors

The following shall apply.

- a) Lower connector: Flanged or studded lower connectors shall be in accordance with 14.1. Other connectors shall be in accordance with 14.9.
- b) Upper connector: The upper connector of an independent adapter shall be flanged or studded in accordance with 14.1, or threaded in accordance with 14.3, or have an OEC in accordance with 14.9 or clamp hub end connectors in accordance with API 16A or swivel flanges in accordance with API 17D. Through-bore tolerances for 5" upper connectors shall be +1.0 mm (+0.04 in.). For all other top connectors, through-bore tolerances shall be +0.8 mm (+0.03 in.) of the nominal bore dimension.

14.14.2.10.3 Rated Working Pressure

The rated working pressure of tubing-head adapters shall be in accordance with 4.3.1.

NOTE The rated working pressure of threaded connectors may limit the rated working pressure of the tubing-head adapter.

14.14.2.10.4 Test, Vent, and Injection Connectors

Testing, vent, and injection connectors used in tubing-head adapters shall be in accordance with 9.3.

14.14.2.10.5 Crossover Adapters

If tubing-head adapters are used as crossover adapters, they shall satisfy the requirements of 14.8.

14.14.2.10.6 Penetrations

The products with penetrations shall meet the requirements of 9.2.

14.14.3 Materials

Material used for bodies, flanges, and other connectors shall conform to Section 6.

Material for lock screws and other parts shall conform to Section 6.

14.14.4 Quality Control/Testing

All heads and adapters shall successfully complete the tests required and described in Section 11.

14.14.5 Marking

All wellheads shall be marked in accordance with Section 12 and Table 55.

Table 55—Marking for Wellhead Equipment

Required Markings	Required Location(s)
API 6A or 6A Temperature class(es) or ratings Material class Product specification level (PSL) Performance requirements (PR) ^a Date of manufacture Manufacturer's name or mark Serial number (if applicable)	Nameplate and/or body
Nominal bore size (if applicable) End and outlet connector size Rated working pressure Bottom preparation Minimum vertical bore	Nameplate and/or body and outside diameter of connector
Thread size (threaded products only)	Nameplate, body, or near thread
Ring groove type and number	Near each connector or thread
Hardness test values (if applicable) (see 12.8)	Adjacent to test location
FOOTNOTE ^a Allowable markings are PR1, PR2, or PR2F, as applicable.	

All casing-head spools and tubing-head spools used as crossover spools shall additionally be marked in accordance with Section 12 and Table 56.

Table 56—Marking for Wellhead Connectors

Required Markings	Required Location(s)
API 6A or 6A Temperature class(es) or ratings Material class Product specification level (PSL) Date of manufacture Manufacturer's name or mark Serial number (if applicable)	Nameplate and/or body
Nominal bore size (if applicable) End and outlet connector size Rated working pressure	Nameplate and/or body and outside diameter of connector
Thread size (threaded products only)	Nameplate, body, or near thread
Packoff casing size	Nameplate or body, and outside diameter of bottom connector
Minimum vertical bore	Nameplate or body, and outside diameter of each connector
Ring groove type and number	Near each connector
Hardness test values (if applicable) (see 12.8)	Adjacent to test location

Casing-head housings, casing-head spools, tubing-head spools, crossover spools, multistage head housings, multistage spools, and adapter and spacer spools shall be marked as specified in Table 55 and Table 56. The bore size shall be preceded by the word "Bore."

NOTE Performance requirement marking is not required for wellhead connectors.

Wellhead outlets with valve removal preparations shall be marked near the outlet with "API 6A" or "6A" followed by the nominal size and "VR" or "HPVR" as applicable.

14.14.6 Storing and Shipping

All heads shall be stored and shipped in accordance with Section 13.

14.15 Chokes

14.15.1 General

NOTE 1 Positive and adjustable chokes are chokes that include restrictions or orifices to control the flow rate of fluids.

NOTE 2 Chokes are not intended to be used as shutoff valves.

NOTE 3 Adjustable chokes have an externally controlled variable-area orifice coupled with an orifice-area-indicating mechanism as shown in Figure 16. Actuators for adjustable chokes are covered in 14.16.

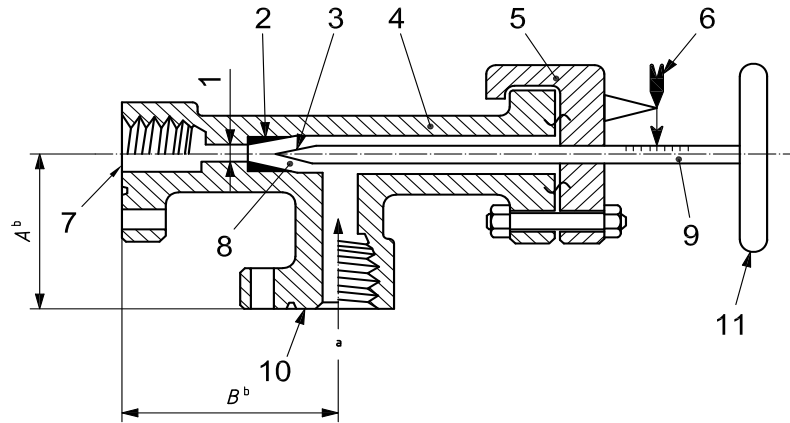

Key

- | | |
|---|-----------------------|
| 1 maximum orifice diameter | 7 outlet connector |
| 2 removable seat | 8 orifice area |
| 3 stem tip | 9 stem |
| 4 body | 10 inlet connector |
| 5 bonnet | 11 handwheel or lever |
| 6 indicating mechanism (type is optional) | |

a Flow direction.

b Dimensions *A* and *B* are agreed between manufacturer and purchaser and may be specified using Figure B.11.

Figure 16—Typical Adjustable Choke

NOTE 4 Positive chokes accommodate replaceable parts having fixed orifice dimensions, which are commonly called flow beans, as shown in Figure 17.

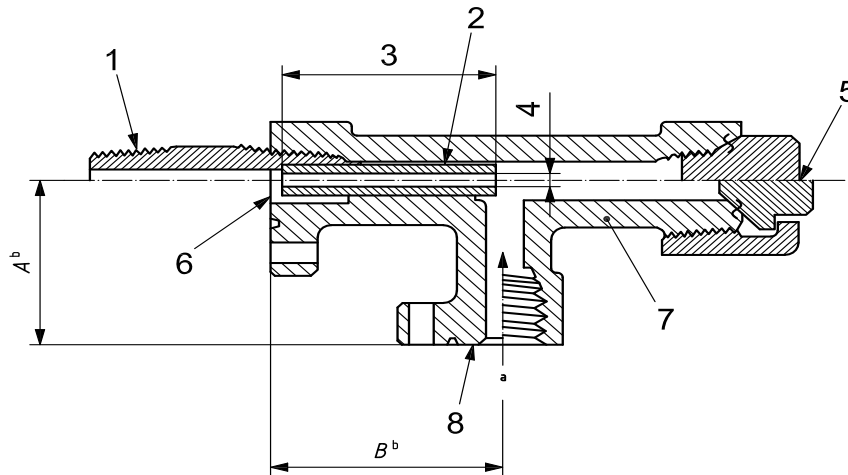

Key

- | | |
|--------------------------|--------------------|
| 1 cage nipple (optional) | 5 plug or cap |
| 2 removable flow bean | 6 outlet connector |
| 3 orifice length | 7 body |
| 4 orifice diameter | 8 inlet connector |

a Flow direction.

b Dimensions *A* and *B* are agreed between manufacturer and purchaser and may be specified using Figure B.11.

Figure 17—Typical Positive Choke

14.15.2 Design

14.15.2.1 General

Chokes shall meet the requirements of Section 4 and Section 5, in addition to those in 14.15.2.2 through 14.15.2.9.

14.15.2.2 Performance Requirements

Chokes shall meet the general performance requirements of 4.2 and shall be capable of performing as outlined in Table 57. This shall include positive chokes, manually actuated chokes, and chokes designed for actuators.

Table 57—Performance Requirements for Chokes

Performance Requirement Level	Operating Cycles ^a	Seat-to-body Sealing
PR1	3 cycles	1 cycle
PR2	200 cycles	3 cycles
FOOTNOTE		
^a Operating cycles do not apply to positive chokes.		

14.15.2.3 End Connectors

End connectors shall conform to 14.1, 14.3, or 14.9.

14.15.2.4 Nominal Size

The nominal size designation of the choke shall be the inlet connector size, followed by the maximum orifice size available for that choke in units of 0.4 mm ($1/64$ in.). If the choke orifice is not a single circular orifice, the maximum size shown shall be the diameter of a circle, in increments of 0.4 mm ($1/64$ in.), whose area is equal to the total choke orifice area.

14.15.2.5 Rated Working Pressure

For chokes having end connectors of the same rated working pressure, the rated working pressure of the choke shall be the rated working pressure of the end connectors.

For chokes having an upstream end connector of higher rated working pressure than the downstream end connector, the choke shall have a two-part rated working pressure consisting of the rated working pressure of the upstream end connector and the rated working pressure of the downstream end connector, for example, 20.7 MPa \times 13.8 MPa (3000 psi \times 2000 psi).

14.15.2.6 Flow Design

Chokes shall be designed to direct flow away from the bonnet of adjustable chokes and the cap, or blanking plug, of positive chokes.

14.15.2.7 Vent Requirement

All chokes shall be designed to vent trapped pressure prior to releasing the body-to-bonnet connector on adjustable chokes or the body-to-cap connector on positive chokes.

14.15.2.8 Flow Beans for Positive Chokes

NOTE 1 Flow beans are defined as the replaceable orifice parts of positive chokes.

The orifice size of any individual production flow bean and the increment between sizes are optional with the manufacturer but shall be specified in diameter increments of 0.4 mm ($1/64$ in.).

Proration beans shall have a net effective orifice length of 152.4 mm \pm 1.5 mm (6 in. \pm 0.06 in.). The orifice diameters of these beans shall be specified in $1/64$ in. diametrical increments, i.e. $5/64$ in., $6/64$ in., $7/64$ in., $8/64$ in.

NOTE 2 The orifice size of any individual production bean and the increment between sizes are optional with the manufacturer.

14.15.2.9 Adjustable Choke Indicating Mechanism

Adjustable chokes shall be equipped with a visible orifice-area-indicating mechanism to define the orifice area at any adjusted choke setting throughout its operating range. This mechanism shall be calibrated to indicate diameters of circular orifices having areas equivalent to the minimum flow areas at any adjustable choke setting. These markings shall be in diametrical increments of either 0.4 mm (1/64 in.) or 0.8 mm (1/32 in.) for choke settings between 0.0 mm (0 in.) and 19.2 mm (3/4 in.), inclusive. For choke settings above 19.2 mm (3/4 in.), diametrical increments of 0.4 mm (1/64 in.), 0.8 mm (1/32 in.), or 1.6 mm (1/16 in.) may be used. It is not required to equip actuated chokes with an indicating mechanism.

14.15.3 Materials

Materials for bodies, bonnets, plugs or caps, and end connectors shall conform to Section 6.

Material for all other parts shall meet the requirements of Section 6 or 14.16, as applicable. Additionally, special corrosion- and abrasion-resistant materials, coatings, or overlays shall be used for adjustable-choke stem tips and positive-choke flow beans.

14.15.4 Quality Control/Testing

Assembled chokes shall successfully complete the tests required by and described in Section 11.

14.15.5 Marking

Choke marking shall be as specified in Section 12 and Table 58.

Table 58—Marking for Chokes

Required Markings	Required Location(s)
API 6A or 6A Temperature class(es) or ratings Material class Product specification level (PSL) Performance requirements (PR) ^a Date of manufacture Manufacturer's name or mark Serial number (if applicable) Nominal bore size (if applicable) Maximum orifice size End and outlet connector size	Nameplate and/or body
Rated working pressure	Nameplate and/or body and outside diameter of connector
Thread size (threaded products only)	Nameplate, body, or near thread
Flow direction	Body
Direction of movement to open	Handwheel
Ring groove type and number	Near each connector or thread
Hardness test values (if applicable) (see 12.8)	Adjacent to test location
FOOTNOTE ^a Allowable markings are PR1, PR2, or PR2F, as applicable.	

Chokes shall be marked with their nominal size and maximum orifice as specified in 14.15.2.4.

Choke beans shall be marked as specified in Table 59, with the orifice size and the manufacturer's name or mark on its outside diameter or end.

Table 59—Marking for Choke Beans

Marking	Location
Manufacturer's name or mark	Outside diameter or end
Size; nominal orifice size; bean size	Outside diameter or end

14.15.6 Storing and Shipping

Chokes shall be stored and shipped in accordance with Section 13.

14.16 Actuators

14.16.1 General

14.16.1.1 Types

This section shall apply to hydraulic, pneumatic, and electric-powered actuators for wellhead and tree equipment including single-acting linear, double-acting linear, and rotary types.

If the actuator is supplied with the associated parts of the valve or choke (bonnet, stem, seals), these parts are not considered part of the actuator and shall meet the requirements of 14.11 or 14.15, respectively. The actuator, if assembled with a valve prepared for an actuator, shall meet the requirements of 14.11.1.3 for actuated valves.

NOTE Actuators powered using retained fluid are not within the scope of this document.

14.16.1.2 Temperature Rating

Actuators shall have a temperature rating, for which metallic materials and nonmetallic seals shall be qualified as required by this specification.

The minimum rating shall be a temperature listed under "min" in Table 2, unless specified otherwise by the manufacturer and purchaser.

The maximum rating shall be no less than 65 °C (150 °F).

NOTE The standard upper temperature rating is 65 °C (150 °F).

14.16.2 Design

14.16.2.1 General

Actuators shall meet the requirements of Section 4 and Section 5, in addition to the requirements in 14.16.2.2 to 14.16.2.8.

14.16.2.2 Performance Requirements

Actuators shall be capable of performing as outlined in Table 60.

Table 60—Performance Requirements for Actuators

Performance Requirement Level	Number of Operating Cycles
PR1	3 cycles
PR2	200 cycles

14.16.2.3 Pressure

The manufacturer shall identify the supply pressure rating of the actuator.

Hydraulic and pneumatic actuators shall be designed to withstand actuator shell test pressure.

14.16.2.4 Fluid Connectors

Hydraulic and pneumatic connectors shall conform to the manufacturer specifications. The connectors shall have a pressure rating equal to or greater than the supply pressure rating of the actuator.

14.16.2.5 Pressure Relief

All actuators shall be designed to prevent pressure build-up within the actuator case due to leakage from the valve, choke, or actuator.

NOTE A provision for relief of pressure build-up may be included in the valve bonnet assembly (and associated parts) as part of either the valve or the actuator.

In pneumatically operated actuators, a relief device shall be provided to relieve at no higher than 120 % of the supply pressure rating of the actuator.

14.16.2.6 Electrical Specifications

Electrical parts shall be in accordance with the requirements of API 14F or the applicable standards of IEC/CENELEC. Control latching (hold-open) power shall be in accordance with the manufacturer's written specification. Thermal protection for the motor shall be provided.

14.16.2.7 Actuation Forces

Actuator output forces shall meet or exceed the operating requirements specified by the valve or choke manufacturer.

14.16.2.8 Interface Requirements

Parts shall conform to applicable interface dimensions and other requirements specified by the valve manufacturer.

14.16.3 Materials**14.16.3.1 Pneumatically or Hydraulically Powered Actuators**

Metallic and nonmetallic materials used in actuators shall have written material specifications.

The manufacturer's written specifications for metallic materials shall define the following:

- mechanical property requirements;
- chemical compositions;
- heat-treatment.

Impact testing for actuator parts that retain pneumatic/hydraulic control fluid and pressure (e.g. pressure cylinders, pistons, and diaphragm housings) shall be in accordance with 6.3.2.3, PSL 1 requirements.

The manufacturer's written specifications for nonmetallic materials shall be in accordance with 6.2.3.

14.16.3.2 Electric Actuators

Materials used for electric actuators shall conform to the manufacturer's written specifications.

14.16.3.3 Traceability

Actuator parts that retain pneumatic/hydraulic control fluid and pressure (e.g. pressure cylinders, pistons, and diaphragm housings) having a rated working pressure greater than 2.6 MPa (375 psi) shall require material traceability. Traceability shall be sufficient if the part can be traced to a job lot that identifies the included heat lot(s). All parts in a multiheat job lot shall be rejected if any heat lot does not conform to the manufacturer's written specifications.

NOTE If heat lot traceability is maintained, conforming heat lots may be retained.

14.16.3.4 Nonmetallic Sealing Elements

Nonmetallic seal materials shall be capable of withstanding the supply pressure rating of the actuator within the temperature rating specified by the manufacturer. The manufacturer shall specify the operating fluid(s) and shall have documentation of the compatibility of the fluid with nonmetallic seals.

Sealing elements shall be controlled in accordance with 10.4.6, PSL 1.

14.16.3.5 Welding Requirements

Welding shall be in accordance with the applicable requirements of Section 7, except that quality control requirements shall be visual examination for fabrication welds. Repair welds shall include liquid penetrant or magnetic particle examination, as applicable, for material defects only.

14.16.4 Quality Control/Testing

14.16.4.1 Actuator Shell Test

Actuator parts that retain pneumatic or hydraulic control fluid and pressure (e.g. pressure cylinders, pistons, and diaphragm housings) shall be subjected to a shell test to demonstrate structural integrity.

NOTE 1 The parts may be tested simultaneously or separately.

In case the bonnet for the mating valve or choke forms an integral part of a loose actuator, the bonnet shall satisfy the requirements of 14.11 or 14.15, respectively. Testing of the bonnet stem packing shall not be required as part of the actuator shell test.

NOTE 2 Water with or without additives, gas, or hydraulic fluid may be used as the testing fluid.

The test pressure shall be a minimum of 1.5 times the supply pressure rating of the actuator. The test shall consist of three parts:

- primary pressure-holding period;
- reduction of the pressure to zero;
- secondary pressure-holding period.

Both pressure-holding periods shall not be less than 3 min. The test period shall not begin until the test pressure has been reached and has stabilized, the equipment and the pressure-monitoring device have been isolated from the pressure source, and the external surfaces of the parts have been thoroughly dried.

Acceptance criteria: The equipment shall show no visible leakage during each holding period.

14.16.4.2 Functional Testing

Each actuator shall be subjected to a functional test to demonstrate proper assembly and operation. The actuator may be tested with the equipment for which it is intended or tested separately. Test media for pneumatic actuators shall be a gas, such as air or nitrogen. Test media for hydraulic actuators shall be a suitable hydraulic fluid or a gas, such as air or nitrogen. Test power supplied to electric actuators shall be in accordance with the electrical design requirements.

The following shall apply in the order shown below.

- a) Test for hydraulic and pneumatic actuator seal: The actuator seals shall be pressure-tested in two steps by applying pressures of no greater than 20 % and no less than 100 % of the supply pressure rating of the actuator. No visible leakage is allowed. The minimum test duration for each test pressure shall be 10 min at 20 % pressure and 5 min at 100 % pressure for pneumatic actuators and 3 min at each test pressure for hydraulic actuators. This test period shall not begin until the test pressure has been reached and has stabilized, and the pressure-monitoring device has been isolated from the pressure source. The test pressure reading and time at the beginning and at the end of each pressure-holding period shall be recorded.
- b) Operational test: The actuator shall be tested for proper operation by cycling the actuator, from the normal position to the fully stroked position, a minimum of three times. The actuator shall operate smoothly in both directions and without noticeable stick-slip or chattering behavior. The final assembly of actuator to valve or choke shall be tested in accordance with Section 11 for the appropriate PSL of the equipment. For BSDVs with actuators sized at differential pressures lower than the valve’s rated working pressure, an operational test shall be performed opening the valve against the sizing differential pressure agreed to between the manufacturer and purchaser after all other testing is completed in Section 11. The latching (hold open) mechanism power requirements for electric actuators shall be tested during the tests required by Section 11.
- c) Gas backseat test: If the bonnet and actuator are furnished as a unit for PSL 4 valves, a test shall be conducted in accordance with 11.3.

NOTE If the bonnet and actuator are furnished as a unit for PSL 3G valves, a test may be conducted in accordance with 11.3.

14.16.5 Marking

All actuators shall be marked as specified in Section 12 and Table 61. Bonnets attached to actuators shall be considered part of the valve for marking purposes.

Table 61—Marking for Actuators

Required Markings	Required Location(s)
API 6A or 6A Temperature class(es) or ratings Performance requirements (PR) ^a Date of manufacture Manufacturer’s name or mark Serial number (if applicable) Supply pressure rating	Nameplate and/or body
Hardness test values (if applicable) (see 12.8)	Adjacent to test location
FOOTNOTE ^a Allowable markings are PR1, PR2, or PR2F, as applicable.	

Marking for electric actuators may be on a separate nameplate on the actuator and shall include, but not be limited to, area classification, voltage, frequency, amperage (starting and running), and motor insulation requirements.

14.16.6 Storage and Shipping

Storage and shipping shall be per Section 13.

14.17 Safety Valves, Shutdown Valves, and Actuators

14.17.1 General

14.17.1.1 Valves

Safety valves shall conform to the applicable requirements of 14.11 for actuated valves or valves prepared for actuator.

NOTE The term "safety valve" can refer to surface safety valve (SSV), underwater safety valve (USV), or boarding shutdown valve (BSDV).

SSVs and USVs shall conform to the requirements for PSL 2 as a minimum.

BSDVs shall conform to the requirements for PSL 3 as a minimum.

Record requirements for SSVs/USVs/BSDVs shall be in accordance with Section 15.

14.17.1.2 Actuators

Actuators for SSVs, USVs, and BSDVs shall meet the requirements of 14.16.

NOTE The term "safety valve actuator" can refer to the actuator of a surface safety valve (SSV), underwater safety valve (USV), or boarding shutdown valve (BSDV).

14.17.2 Design

14.17.2.1 General

Safety valves shall be designed for and constructed of materials conforming to Section 6 and shall perform satisfactorily in the tests required by 14.17.2.3.3.

The safety valve shall be of a normally closed design. The safety valve shall be designed to operate, without damage to the safety valve or safety valve actuator, when the valve is actuated open or closed, pressurized or depressurized, under any internal valve body pressure within its pressure rating, and for USV, under any external pressure up to sea pressure at the maximum depth rating.

If grease or sealant is required in the safety valve body or stem area, provisions shall be made for injecting the grease or sealant without reducing the pressure in the safety valve.

Design criteria for USVs shall include maximum water depth.

Safety valves shall have end connectors conforming to 14.11, except that threaded end connectors shall not be used.

14.17.2.2 Performance Requirements

14.17.2.2.1 Valves

Safety valves shall be designed to satisfy the performance requirements specified in Table 62 and shall be validated as specified in 14.17.2.3.3.

Table 62—Summary of Validation Requirements for Safety Valves

Safety Valve Service Class	Performance Requirements		Testing Requirements	
	Operating Cycles	Thermal Cycles	Design Validation Testing	6AV1 Sand Slurry Testing
I	200	3	PR2F	Not required ^a
II	200	3	PR2F	API 6AV1 Class II
III	200	3	PR2F	API 6AV1 Class III
FOOTNOTE ^a Manufacturer may perform an API 6AV1 Class II test replacing the sand slurry with plain water as the test fluid.				

14.17.2.2.2 Actuators

Actuators for safety valves shall be designed to satisfy the PR2 level of 14.16.2 as a minimum.

14.17.2.3 Product-specific Design Requirements

14.17.2.3.1 SSV Design

NOTE An SSV valve may be a single loose valve or one valve in a multiple valve body.

Multiple and block valves shall be manufactured and supplied in accordance with all other applicable requirements of this specification. Single-unit SSV valves shall conform to the bore diameter, face-to-face length, and other applicable dimensions specified in 14.11.

14.17.2.3.2 USV and BSDV Design

NOTE A USV/BSDV valve may be a single loose valve or one valve in a multiple valve body.

USV and BSDV designs shall meet the requirements of 14.17.2.3.1 for SSV design, with the following exceptions.

- USV/BSDV may use end connectors as specified in API 17D as well as end connectors in this specification, except as noted in 14.17.2.1.
- USVs may be of nonstandard bores and/or face-to-face lengths. End connectors shall meet all other requirements of this specification.
- BSDVs may be of nonstandard bores and/or face-to-face lengths. End connectors shall meet all other requirements of this specification. Reduced-opening BSDV flow ports shall be sized in accordance with the inside diameters of piping upstream or downstream of the BSDV.

14.17.2.3.3 Valve Design Validation Testing

NOTE 1 See Table 62 for a summary of validation requirements.

Validation of a single-unit safety valve shall validate a multiple- or block-type valve for performance requirement PR2F and Class I, II, or III service, without additional validation testing, if it is of the same internal design as a safety valve within the manufacturer’s product line that has passed the required validation testing, and if all other scaling requirements are satisfied.

The following shall apply.

- a) Class I service: To validate a Class I safety valve, the PR2F procedures of Annex F shall be completed.
- b) Class II and III service: To validate a specific safety valve design for service Class II or III, the Class I requirements (PR2F) shall be satisfied. In addition, the valve shall pass the Class II or Class III testing in accordance with API 6AV1.
- c) Test requirements and scaling: For PR2F validation, the scaling provisions of F.1.14 shall apply.

NOTE 2 This includes scaling by temperature rating, pressure rating, and design family.

- 1) For API 6AV1 Class II or III validation, the scaling provisions of API 6AV1 shall apply.
- 2) For PR2F and 6AV1 validation: Validation of an SSV or USV or BSDV validates the other two types of safety valve with the same valve bore sealing mechanism and design family. The safety valve shall be tested with an actuator that meets the requirements of 6AV1.

NOTE 3 It is not required that a single valve be consecutively tested to 6A PR2F and 6AV1. The tests are not cumulative.

- d) Test agency: To validate a specific Class II or Class III safety valve design for sandy service, the manufacturer shall submit a safety valve of the same basic design and materials of construction to a test agency (3.1.95).

NOTE 4 An independent test agency is required for the testing specified in API 6AV1 to validate the performance of the valve bore sealing mechanism for Class II or Class III service. An independent test agency is not required for validation testing of Annex F PR2 (PR2F).

The test agency and test report number for Class II or Class III safety valves shall be identified in the shipping report (see 15.4.2).

14.17.2.3.4 Actuator Design

The actuator closing force shall be sufficient to close the SSV/USV/BSDV safety valve when it is at the most severe design-closing condition specified by the valve manufacturer.

Internal parts should be resistant to environmental corrosion, the operating medium, and the other fluids to which they can be exposed under operating conditions defined by the manufacturer and/or the purchaser.

Permanently attached lock-open features shall not be permitted on SSV or BSDV actuators.

14.17.2.3.5 Heat-sensitive Lock-open Devices (SSVs and BSDVs Only)

14.17.2.3.5.1 General

Heat-sensitive lock-open devices, when included, shall maintain the SSV or BSDV in the fully open position at atmospheric temperatures up to 65 °C (150 °F) with the valve body pressurized to its rated working pressure and the actuator supply pressure bled to atmospheric conditions. The lock-open device shall be designed such that any part released upon actuation of the device shall not create a potential hazard to personnel.

The following temperature actuation conditions shall be met.

- The lock-open device shall allow the valve to automatically close from actuator forces alone (i.e. no pressure in the valve body or energy supply to the actuator cylinder) within 6 min after being subjected to, and maintained in, a controlled environmental temperature of 540 °C ± 14 °C (1000 °F ± 25 °F).

- Eutectic materials used shall meet the manufacturer's design requirements for fusing within a temperature range of $\pm 10\%$ around the nominal melting point. The heat-sensitive device shall be designed to actuate at a maximum sustained temperature of 200 °C (400 °F).

14.17.2.3.5.2 Validation Testing of Heat-sensitive Lock-open Devices

Tests to confirm the design requirements of 14.17.2.3.5 shall be done in an air environment with air velocity past the SSV actuator due to natural air convection only. The manufacturer shall have data available to show that the device has been sufficiently tested to ensure that it can satisfy the design requirements.

14.17.3 Materials

14.17.3.1 Valves

Pressure-containing and pressure-controlling parts of safety valves shall be designed for and constructed of materials in conformance with Section 6.

14.17.3.2 Actuators

Materials for safety valve actuators shall meet the requirements of 14.16.3.

14.17.4 Quality Control/Testing

14.17.4.1 Drift Test

All assembled full-bore safety valves and safety valves prepared for actuators shall pass a drift test as described in 11.4. Safety valves prepared for actuators shall be drift tested with the valve bore sealing mechanism installed to verify the capability.

NOTE Drift testing of reduced-bore USVs or BSDVs is not required.

14.17.4.2 Acceptance Testing

All assembled safety valves or safety valves prepared for actuators with simulated bonnets shall pass all applicable tests required and described in Section 11, as a minimum. For BSDVs with actuators sized at differential pressures lower than the valve's rated working pressure, an operational test shall be performed opening the valve against the sizing differential pressure agreed to between the manufacturer and purchaser after all other testing of Section 11 is completed. All test data shall be recorded on a test data sheet (see 15.4.3).

14.17.5 Marking

Safety valves and safety valve actuators shall have nameplates affixed. Nameplates shall be made of material having corrosion resistance equivalent to or better than 18-8 austenitic stainless steel.

Safety valves shall be marked as specified in Section 12 and Table 63.

Table 63—Marking for Safety Valves

Required Markings	Required Location(s)
API 6A or 6A and valve type ^{a,b} Temperature class(es) or ratings Material class Product specification level (PSL) Product class ^c Date of manufacture Manufacturer's name or mark Serial number Nominal bore size (if applicable) End and outlet connector size	Nameplate and/or body
Rated working pressure Maximum valve differential pressure ^d	Nameplate and/or body and outside diameter of each connector
Ring groove type and number	Near each connector
Flow direction (unidirectional valves only)	Body
Hardness test values (if applicable) (see 12.8)	Adjacent to test location
FOOTNOTES ^a Additional allowable markings are SSV, USV, or BSDV. ^b For valves prepared for actuators, mark the letter "V" after "API 6A" or "6A." ^c Allowable markings are I, Class I, II, Class II, III, or Class III. ^d Maximum valve (flow bore sealing mechanism) differential pressure for BSDV only.	

14.17.6 Storage and Shipping

14.17.6.1 Valves

All safety valves shall be stored and shipped in accordance with Section 13.

14.17.6.2 Actuators

All safety valve actuators shall be stored and shipped in accordance with Section 13.

14.17.6.3 Assembled SSV/USV/BSDV

All assembled safety valves shall be stored and shipped in accordance with Section 13.

14.18 Tree Assemblies

14.18.1 General

NOTE Requirements for tree assemblies, including trees for single- and multiple-tubing string installations, and block trees for single- and multiple-tubing string installations, are covered in 14.18.

14.18.2 Design

NOTE See design requirements for equipment.

14.18.3 Materials

NOTE See material requirements for equipment.

14.18.4 Quality Control/Testing/Assembly

All parts and equipment shall conform to the requirements of this specification before being assembled into trees.

Trees shall successfully complete the hydrostatic body and drift tests required by and described in Section 11. For trees assembled with components having different PSLs, hold period requirements for the highest PSL shall apply.

14.18.5 Marking

Assembled trees shall be tagged with the information as specified in Table 64.

Table 64—Marking for Trees

Marking	Location
Date of final acceptance	Tag or nameplate
Name of manufacturer	Tag or nameplate
Location of manufacturer	Tag or nameplate

14.18.6 Storing and Shipping

Trees shall be stored and shipped in accordance with Section 13. Any disassembly, removal, or replacement of parts or equipment after testing shall be as agreed with the purchaser.

15 Records

15.1 General

15.1.1 NACE MR0175/ISO 15156 Record Requirements

Records required to substantiate conformance of material classes DD, EE, FF, and HH equipment to NACE MR0175/ISO 15156 requirements shall be in addition to those described in 15.2, unless the records required by this specification also satisfy the NACE MR0175/ISO 15156 requirements.

15.1.2 Record Control

Quality control records required by this specification shall be legible, identifiable, retrievable, and protected from damage, deterioration, or loss.

Quality control records required by this specification shall be retained by the manufacturer for a minimum of 10 years following the date of manufacture as marked on the equipment associated with the records.

All quality control records required by this specification shall be signed and dated.

NOTE Signatures may be digital.

15.2 Records Maintained by Manufacturer

15.2.1 Records of Pressure Tests

For PSL 3 and PSL 4, the following records shall be maintained.

- A pressure recording device shall be used on all hydrostatic tests. The record shall identify the recording device, shall be dated, and shall be signed.
- Records of gas testing shall document test parameters and acceptance.

NOTE 1 Pressure recording of gas testing is not required.

- If the pressure recording device is not qualified as a pressure-measuring device in accordance with 10.2.2, it shall be used in parallel with a calibrated pressure-measuring device, and the pressure-measuring device readings at the start and stop of each hold period shall be included as part of the record.

NOTE 2 Both the chart and the signature can be digital or analog.

NOTE 3 The pressure test requirements do not apply to PSL 1 and PSL 2.

15.2.2 Body, Bonnet, End and Outlet Connectors, Stem, Valve Bore Sealing Mechanism, Mandrel Tubing Hanger, Mandrel Casing Hanger, Slip Bowl, and Slip Segment Records

15.2.2.1 PSL 1 Equipment

For PSL 1, the following records shall be maintained for bodies, bonnets, end and outlet connectors, stem, valve bore sealing mechanisms, mandrel tubing hangers, mandrel casing hangers, slip bowls, and slip segments:

- 1) material test records:
 - chemical analysis,
 - tensile test,
 - impact test (if required),
 - hardness test;
- 2) welding process records:
 - weld procedure specification,
 - weld PQR,
 - welder qualification record;
- 3) NDE personnel qualification records, when NDE is required;
- 4) hardness test (if applicable).

15.2.2.2 PSL 2 Equipment

For PSL 2, the following records shall be maintained for bodies, bonnets, end and outlet connectors, stem, valve bore sealing mechanisms, mandrel tubing hangers, and mandrel casing hangers:

- 1) all records required for PSL 1 (see 15.2.2.1);
- 2) NDE records:
 - surface NDE records,
 - weld volumetric NDE records,
 - repair weld NDE records;
- 3) heat-treatment certification of compliance.

15.2.2.3 PSL 3 Equipment

For PSL 3, the following records shall be maintained for bodies, bonnets, end and outlet connectors, stem, valve bore sealing mechanisms, and mandrel tubing hangers, mandrel casing hangers:

- 1) all records required for PSL 2 (see 15.2.2.2);
- 2) all required records shall reference the specific part serial number;
- 3) volumetric NDE records (except valve bore sealing mechanisms);
- 4) heat-treatment record:
 - actual temperature,
 - actual times at temperature,
 - certification of compliance is not required;
- 5) hardness test record, actual hardness;
- 6) welding process records:
 - welder identification,
 - weld procedures,
 - filler material type,
 - post-weld heat-treatments;
- 7) records that dimensional inspection was performed (those activities required by 10.4.2.5).

15.2.2.4 PSL 4 Equipment

For PSL 4, the records maintained for bodies, bonnets, end and outlet connectors, stem, valve bore sealing mechanisms, mandrel tubing hangers, and mandrel casing hangers shall be the same as PSL 3 (15.2.2.3).

For bodies, bonnets, end and outlet connectors, stems, mandrel tubing and casing hangers shall require actual heat-treatment temperature charts showing times and temperatures.

The melting practice used (bodies, bonnets, and end and outlet connectors only) shall be identified.

15.2.3 Ring Gaskets and Nonintegral Metal Seals Records

NOTE No records are required.

15.2.4 Closure Bolting Records

If BSL 2 or BSL 3 is specified per Table 15, closure bolting records that are required by API 20E or API 20F to be submitted to the purchaser shall be maintained.

15.2.5 Nonmetallic Sealing Material Records

Nonmetallic sealing material records are required and shall be in accordance with 10.4.6.

15.2.6 Bullplugs, Valve-removal Plugs, and Back-pressure Valve Records

The following material test records shall be maintained:

- chemical analysis;
- tensile test;
- impact test (if testing is performed);
- hardness test.

15.2.7 Assembled Equipment Records

For PSL 1 assembled equipment, no records shall be required.

For PSL 2 assembled equipment, the following pressure test records shall be maintained:

- actual test pressure;
- holding period duration;
- additionally, for USVs, SSVs, and BSDVs, the requirements of 15.4 shall apply.

For PSL 3 assembled equipment, the following records shall be maintained:

- all records required for PSL 2;
- additionally, the following records shall be maintained:
 - a) assembly traceability records,
 - b) hydrostatic pressure test records;
- furthermore, the following gas-test records shall be maintained for equipment designated PSL 3G:
 - a) actual test pressures,
 - b) actual holding period durations.

For PSL 4 assembled equipment, the following records shall be maintained:

- all records required for PSL 3;
- additionally, the following gas-test records shall be maintained:
 - a) actual test pressures,
 - b) actual holding period durations.

15.2.8 Choke Trim Records

For PSL 1 and PSL 2 choke trim, no records shall be required.

For PSL 3 and PSL 4 choke trim, surface NDE records shall be maintained.

15.3 Records Furnished to Purchaser

15.3.1 General

These records shall be provided by the manufacturer to the original purchaser of equipment made to conform to this specification.

These records, if applicable, shall be identical to or contain the same information as those retained by the manufacturer.

These records provided by the manufacturer shall prominently reference part serial number(s) (PSL 3 and PSL 4).

15.3.2 Body, Bonnet, End and Outlet Connectors, Stem, Valve Bore Sealing Mechanism, Mandrel Tubing Hanger, Casing Hanger, and Back-pressure Valve Records

For PSL 1, PSL 2, and PSL 3, no records shall be required for bodies, bonnets, end and outlet connectors, stem, valve bore sealing mechanisms, mandrel tubing hangers, casing hangers, and back-pressure valves.

For PSL 4 bodies, bonnets, end and outlet connectors, stem, valve bore sealing mechanisms, mandrel tubing hangers, casing hangers, and back-pressure valves, the following records shall be furnished to the purchaser:

- NDE records;
- hardness test records;
- material test records;
- heat-treatment records.

15.3.3 Ring Gasket and Nonintegral Metal Seals Records

No records shall be required.

15.3.4 Closure Bolting Records

No records shall be required.

15.3.5 Nonmetallic Sealing Material Records

For PSL 1, PSL 2, and PSL 3, no nonmetallic sealing material records shall be required.

For PSL 4, a certificate of conformance stating that nonmetallic seals conform to PSL 4 of this specification shall be furnished to the purchaser.

15.3.6 Slip Hanger Records

A certificate of conformance stating that equipment meets the requirements of this specification, including the temperature class/rating and material class, shall be furnished to the purchaser.

15.3.7 Assembled Equipment Records

NOTE See 15.4 for additional record requirements of BSDVs, USVs, and SSVs.

For PSL 1 and PSL 2 assembled equipment, no records shall be required.

For PSL 3 assembled equipment, the following records shall be furnished to the purchaser:

- certificate of conformance stating that equipment meets the requirements of PSL 3 of this specification, and the temperature and material class;
- assembly traceability records;
- pressure test records (see 15.2.1).

For PSL 3G and PSL 4 assembled equipment, the following records shall be furnished to the purchaser:

- all records/certifications for PSL 3;
- gas-test records (see 15.2.1).

15.4 SSV, USV, and BSDV Records

15.4.1 General

Record requirements for SSV/USV/BSDV valves shall be in accordance with 15.2.7, 15.3.7, and the additional requirements given in 15.4.

15.4.2 Shipping Report

The test agency and test report number for Class II or Class III safety valves shall be identified in the shipping report, as shown in the example of Figure 18.

Safety Valve Assembly Shipping Report	
Safety valve data: (circle type) SSV USV BSDV Manufacturer _____	
Valve part no. or model _____	Serial no. _____
Size _____	Rated working pressure _____ PSL _____ Material class _____
Temperature class _____	or Temperature rating: Max. _____ Min. _____
Service class _____	Test agency _____ Test report no. _____
Valve differential pressure for actuator sizing (BSDVs only): _____	
Accepted by _____	Date of manufacture (month and year) _____
Actuator data: (circle type): Hydraulic Pneumatic Electric	
Manufacturer _____	Date of manufacture (month and year) _____
Part/model no. _____	Serial no. _____ Size _____
Max. supply pressure rating _____	Temperature rating _____
Accepted by _____	Date of manufacture (month and year) _____
Safety valve and actuator assembly: (circle type) SSV USV BSDV	
Assembler/manufacturer _____	
Assembly part no. or model _____	Serial no. _____
Accepted by _____	Date of manufacture (month and year) _____

Figure 18—Example of a Safety Valve Shipping Report

15.4.3 Test Data Sheet

All test data shall be recorded on a test data sheet. An example is shown in Figure 19; other formats to include applicable tests are acceptable, but they shall include the same information as a minimum.

15.4.4 Records Furnished to Purchaser

The following shall be furnished to the purchaser for each valve:

- completed functional test data sheet as specified in 14.17.4.2;
- shipping report in accordance with Figure 18;

NOTE An example is shown in Figure 18; other formats are acceptable, but they shall include the same information as a minimum.

- operating manual meeting the requirements of 15.4.5.4 shall be furnished to the purchaser;
- assembly traceability records.

Safety Valve Assembly Factory Acceptance Test Data Sheet

Safety valve data: (circle type) **SSV USV BSDV** / Manufacturer _____

Valve part no. or model _____ Serial no. _____

Size _____ Rated working pressure _____ Temperature class/rating _____

PSL _____ Service class _____ Test agency _____ Test report no. _____

Valve differential pressure for actuator sizing (BSDVs only): _____

Actuator data: (circle type): **Hydraulic Pneumatic Electric** / Manufacturer _____

Part/model no. _____ Serial no. _____ Size _____

Max. supply pressure _____ Temperature rating _____ PSL _____

Actuator seal test: Performed by _____ Date _____

At 20 % of supply pressure rating:

Start time _____ Pressure at start _____ End time _____ Pressure at end _____

At 100 % of supply pressure rating:

Start time _____ Pressure at start _____ End time _____ Pressure at end _____

Actuator operational test: Performed by _____ Date _____

Number of cycles completed _____ Comment (opt) _____

Valve shell test: Performed by _____ Date _____

Primary hold period:

Start time _____ Pressure at start _____ End time _____ Pressure at end _____

Secondary hold period:

Start time _____ Pressure at start _____ End time _____ Pressure at end _____

Valve seat test: Performed by _____ Date _____

Primary hold period (Side A):

Start time _____ Pressure at start _____ End time _____ Pressure at end _____

Secondary hold period (Side A):

Start time _____ Pressure at start _____ End time _____ Pressure at end _____

Tertiary hold period (Side A):

Start time _____ Pressure at start _____ End time _____ Pressure at end _____

Primary hold period (Side B):

Start time _____ Pressure at start _____ End time _____ Pressure at end _____

Secondary hold period (Side B):

Start time _____ Pressure at start _____ End time _____ Pressure at end _____

Tertiary hold period (Side B):

Start time _____ Pressure at start _____ End time _____ Pressure at end _____

Certified by _____ Title _____

Company _____ Date _____

Figure 19—Example of a Safety Valve Factory Acceptance Test Data Sheet

15.4.5 Minimum Contents of Manufacturer's Operating Manual

15.4.5.1 Design Information

The manufacturer's operating manual for safety valves shall include the following:

- type, model, and size for which the manual is applicable;
- performance requirements for which these types, model, and sizes are suitable;
- temperature and working pressure ranges for which the unit(s) is designed;
- drawings and illustrations giving dimensional data of unit(s), as required, for installation or operation;
- parts list.

15.4.5.2 Inspection and Testing

The following minimum inspection and testing information shall be included:

- checklist for visual inspection prior to hook-up;
- written and graphic instructions for field hook-ups;
- appropriate test procedures.

15.4.5.3 Installation

Proper installation methods shall be clearly written and illustrated as necessary. Any necessary preliminary lubrication or greasing shall be specified in detail. Warnings to indicate potential danger to personnel or cautions to indicate potential danger to equipment shall be clearly marked "Warning" or "Caution."

15.4.5.4 Operation and Maintenance

The following minimum operation and maintenance information shall be included in the manufacturer's operating manual:

- maintenance requirements, including recommended intervals of maintenance;
- proper operating techniques;
- disassembly and assembly instructions;
- assembly diagram showing individual parts in proper relationship to one another;
- repair instructions and precautions, including a chart listing symptom, probable cause(s) of the problem, and repairs necessary.

15.4.6 Failure Reporting

NOTE Failure reporting is an essential element of the US federal regulatory program covering gas and oil production in the Outer Continental Shelf.

After receiving a failure report from the operator, the manufacturer of the safety valve equipment shall respond within 6 weeks of receipt, describing progress in the failure analysis. The manufacturer shall also notify the operator in writing of the results of the analysis and the corrective action. If the failure analysis causes the equipment manufacturer to change the design, assembly, or operating procedures of a model of equipment, the manufacturer shall, within 30 days of such changes, report them in writing to all purchasers and known operators of equipment having potential problems.

Annex A (informative)

API Monogram Program **Use of the API Monogram by Licensees**

A.1 Scope

The API Monogram® is a registered certification mark owned by the American Petroleum Institute (API) and authorized for licensing by the API Board of Directors. Through the API Monogram Program, API licenses product manufacturers to apply the API Monogram to new products that comply with product specifications and have been manufactured under a quality management system that meets the requirements of API Q1. API maintains a complete, searchable list of all Monogram licensees on the API Composite List website (<http://compositelist.api.org>).

The application of the API Monogram and license number on products constitutes a representation and warranty by the licensee to API and to purchasers of the products that, as of the date indicated, the products were manufactured under a quality management system conforming to the requirements of API Q1 and that the product conforms in every detail with the applicable standard(s) or product specification(s). API Monogram Program licenses are issued only after onsite audits have verified that an organization has implemented and continually maintained a quality management system that meets the requirements of API Q1 and that the resulting products satisfy the requirements of the applicable API product specification(s) and/or standard(s). Although any manufacturer may claim that its products meet API product requirements without monogramming them, only manufacturers with a license from API can apply the API Monogram to their products.

Together with the requirements of the API Monogram license agreement, this annex establishes the requirements for those organizations who wish to voluntarily obtain an API license to provide API monogrammed products that satisfy the requirements of the applicable API product specification(s) and/or standard(s) and API Monogram Program requirements.

For information on becoming an API Monogram licensee, please contact API, Certification Programs, 1220 L Street, NW, Washington, DC 20005 at certification@api.org.

A.2 Normative References

For licensees under the Monogram Program, the latest version of this document shall be used. The requirements identified therein are mandatory.

A.3 Terms and Definitions

For purposes of this annex, the following terms and definitions apply.

A.3.1

API monogrammmable product

Product that has been newly manufactured by an API licensee utilizing a fully implemented API Q1 compliant quality management system and that meets all the API-specified requirements of the applicable API product specification(s) and/or standard(s).

A.3.2

API product specification

Prescribed set of rules, conditions, or requirements attributed to a specified product that address the definition of terms; classification of components; delineation of procedures; specified dimensions;

manufacturing criteria; material requirements, performance testing, design of activities; and the measurement of quality and quantity with respect to materials; products, processes, services, and/or practices.

A.3.3

API-specified requirements

Requirements, including performance and licensee-specified requirements, set forth in API Q1 and the applicable API product specification(s) and/or standard(s).

NOTE Licensee-specified requirements include those activities necessary to satisfy API-specified requirements.

A.3.4

design package

Records and documents required to provide evidence that the applicable product has been designed in accordance with API Q1 and the requirements of the applicable product specification(s) and/or standard(s).

A.3.5

licensee

Organization that has successfully completed the application and audit process and has been issued a license by API to use the API Monogram Mark.

A.4 Quality Management System Requirements

An organization applying the API Monogram to products shall develop, maintain, and operate at all times a quality management system conforming to API Q1.

A.5 Control of the Application and Removal of the API Monogram

Each licensee shall control the application and removal of the API Monogram in accordance with the following.

- a) Products that do not conform to API-specified requirements shall not bear the API Monogram.
- b) Each licensee shall develop and maintain an API Monogram marking procedure that documents the marking/monogramming requirements specified by this annex and any applicable API product specification(s) and/or standard(s). The marking procedure shall:
 - 1) define the authority responsible for application and removal of the API Monogram and license number;
 - 2) define the method(s) used to apply the Monogram and license number;
 - 3) identify the location on the product where the API Monogram and license number are to be applied;
 - 4) require the application of the date of manufacture of the product in conjunction with the use of the API Monogram and license number;
 - 5) require that the date of manufacture, at a minimum, be two digits representing the month and two digits representing the year (e.g. 05-12 for May 2012) unless otherwise stipulated in the applicable API product specification(s) or standard(s); and
 - 6) define the application of all other required API product specification(s) and/or standard(s) marking requirements.

- c) Only an API licensee shall apply the API Monogram and its designated license number to API monogramable products.
- d) The API Monogram and license number, when issued, are site-specific and subsequently the API Monogram shall only be applied at that site specific licensed facility location.
- e) The API Monogram may be applied at any time appropriate during the production process but shall be removed in accordance with the licensee's API Monogram marking procedure if the product is subsequently found to be out of conformance with any of the requirements of the applicable API product specification(s) and/or standard(s) and API Monogram Program.

For certain manufacturing processes or types of products, alternative API Monogram marking procedures may be acceptable. Requirements for alternative API Monogram marking are detailed in the API Alternative Marking Agreement (AMA), which is available on the API Monogram Program website at https://www.api.org/~media/Files/Certification/Monogram-APIQR/0_API-Monogram-APIQR/Resources/API-Monogram-Alt-Marking-Agreement_Rev-8_FM-011_Modified-20180601.pdf.

A.6 Design Package Requirements

Each licensee and/or applicant for licensing shall maintain a current design package for all of the applicable products that fall under the scope of each Monogram license. The design package information shall provide objective evidence that the product design meets the requirements of the applicable and most current API product specification(s) and/or standard(s). The design package(s) shall be made available during API audits of the facility.

In specific instances, the exclusion of design activities is allowed under the Monogram Program, as detailed in Advisory # 6, available on the API Monogram Program website at <https://www.api.org/products-and-services/api-monogram-and-apiqr/advisories-updates>.

A.7 Manufacturing Capability

The API Monogram Program is designed to identify facilities that have demonstrated the ability to manufacture equipment that conforms to API specifications and/or standards. API may refuse initial licensing or suspend current licensing based on a facility's level of manufacturing capability. If API determines that additional review is warranted, API may perform additional audits (at the organization's expense) of any primary subcontractors to ensure their compliance with applicable specifications.

Facilities with capabilities that are limited to the processes or activities defined below do not meet the manufacturing capability requirements to produce new products, and therefore, shall not be licensed or be the basis for licensing under the API Monogram Program:

- capabilities that are limited to performing final inspection and testing of the product, except for testing agencies as specified in API 14A and/or API 6AV1;
- buying, selling, and/or distributing finished products and materials;
- design and development activities;
- tearing-down and/or reassembling of products/components; and
- repairing or remanufacturing of existing, used, worn, or damaged products.

In all instances where requirements for manufacturing or manufacturing facilities are explicitly identified within the API product specification, those requirements shall take precedence over this advisory.

A.8 Product Marking Requirements

A.8.1 General

These marking requirements shall apply only to those API licensees wishing to mark applicable products in conjunction with the requirements of the API Monogram Program.

A.8.2 Product Specification Identification

Manufacturers shall mark products as specified by the applicable API specifications or standards. Marking shall include reference to the applicable API specification and/or standard. Unless otherwise specified, reference to the API specifications and/or standards shall be, as a minimum, "API [Document Number]" (e.g. API 6A, or API 600). Unless otherwise specified, when space allows, the marking may include use of "Spec" or "Std," as applicable (e.g. API Spec 6A or API Std 600).

A.8.3 Units

Products shall be marked with units as specified in the API specification and/or standard. If not specified, equipment shall be marked with USC units. Use of dual units [USC units and metric (SI) units] may be acceptable, if such units are allowed by the applicable product specification and/or standard.

A.8.4 Nameplates

Nameplates, when applicable, shall be made of a corrosion-resistant material unless otherwise specified by the API specification and/or standard. Nameplate shall be located as specified by the API specification and/or standard. If the location is not specified, then the licensee shall develop and maintain a procedure detailing the location to which the nameplate shall be applied. Nameplates may be attached at any time during the manufacturing process.

The API Monogram and license number shall be marked on the nameplate, in addition to the other product marking requirements specified by the applicable product specification and/or standard.

A.8.5 License Number

The API Monogram license number shall not be used unless it is marked in conjunction with the API Monogram. The license number shall be used in close proximity to the API Monogram.

A.9 API Monogram Program: Nonconformance Reporting

API solicits information on products that are found to be nonconforming to API-specified requirements, as well as field failures (or malfunctions), which are judged to be caused by either specification and/or standard deficiencies or nonconformities against API-specified requirements. Customers are requested to report to API all problems with API monogrammed products. A nonconformance may be reported using the API Nonconformance Reporting System available at <http://ncr.api.org/ncr.aspx>.

Annex B (informative)

Purchasing Guidelines

B.1 General

Annex B provides guidelines for enquiry and purchase of wellhead and tree equipment. These guidelines consist of data sheets for completion by the purchaser, a series of typical wellhead and tree configurations, and a decision tree for determining PSLs.

The data sheets are designed to perform two functions:

- a) assist the purchaser's decision-making process;
- b) assist the purchaser in communicating specific needs and requirements, as well as information on the well environment, to the manufacturer for use in designing and producing equipment.

To use this annex, a copy of the data sheets should be completed as accurately as possible. The typical configurations should be referred to, as needed, to select the required equipment. The decision tree, given in Figure B.15, together with its instructions, provides the recommended practice as to which PSL each piece of equipment should be manufactured. A copy of the data sheet should then be attached to the purchase order or request for proposal.

B.2 Data Sheets

The following pages contain questions and information that can be used to select wellhead equipment, including chokes and actuators. Figure B.1 contains general information that pertains to the entire well. Figure B.2 through Figure B.12 are designed for use with each type of equipment.

The effects of external loads (i.e. bending moments, tensions, etc.) on the assembly of parts are not explicitly addressed by this specification (see 4.3.1.3). The purchaser should specify any exceptional loading configuration.

The purchaser should identify applications that involve fatigue and take appropriate actions to mitigate risk via alternate design methods or other means that have been proven effective.

The purchaser should specify whether the design validation procedures in Annex F are applicable.

Wellhead Equipment Data Sheet—General						
Well name(s) and location(s): _____						
Maximum operating pressure: _____						
Anticipated wellhead shut-in pressure: _____						
Temperature ranges anticipated: _____						
Minimum ambient temperature: _____						
Maximum flowing fluid temperature at wellhead: _____						
Anticipated composition of produced fluids: CO ₂ _____ (mg) _____ Chlorides _____ (mg)						
_____ H ₂ S _____ (mg) _____ Other _____						
Water or brine pH: _____						
Does NACE MR0175/ISO 15156 apply? _____						
Anticipated production rates: _____ m ³ /d oil/condensate						
_____ m ³ /d gas						
_____ m ³ /d S&W ^a						
Will erosion be a concern? Cause: _____						
Will scale, paraffin, corrosion, or other types of inhibitors be used? _____						
Inhibitor type: _____ Inhibitor carrier: _____ Batch or continuous inhibition? _____						
Will acidification be performed? _____ Type of acid: _____						
External coating? Yes, type _____ No _____						
Internal coating? Yes, type _____ No _____						
Delivery requirements: _____						
Special shipping, packing, and storage instructions: _____						
Casing program						
		Top Joint in String				
	Size (OD)	kg/m (lb/ft)	Grade	Connection	Max./Min. Casing Load daN (lb)	Bit Size mm (in.)
Conductor	_____	_____	_____	_____	_____	_____
Surface casing	_____	_____	_____	_____	_____	_____
Protective casing	_____	_____	_____	_____	_____	_____
Production casing	_____	_____	_____	_____	_____	_____
Tubing	_____	_____	_____	_____	_____	_____
Type of completion: single or multiple _____						
FOOTNOTE						
^a Sand and water.						

Figure B.1—Wellhead Equipment Data Sheet—General

Wellhead Equipment Data Sheet—Casing-head Housing	
Casing-head housing	PSL: _____ PR: _____
Bottom connector:	Size: _____ Rated working pressure: _____ Type: _____
Top connector:	Size: _____ Rated working pressure: _____ Type: _____
Outlets:	Size: _____ Rated working pressure: _____ Type: _____ Number: _____
Equipment for outlets:	Valve-removal plug: _____ Valves (right): Qty _____ Typ _____ PSL _____ PR _____ Valves (left): Qty _____ Typ _____ PSL _____ PR _____ Companion flanges: Qty _____ Typ _____ PSL _____ Bullplugs: Qty _____ Nipples: Qty _____ Needle valves: Qty _____ Gauges: Qty _____
Lock screws? Yes _____ No _____	Lock screw function: _____
Baseplate requirements: _____	
Special material requirements: _____	
Casing hanger: Size:	Type: _____
	PSL: _____
	PR: _____
Temperature rating (Table 2): _____	
Material class (Table 3): _____	
Retained fluid corrosivity (Table B.1): _____	
Witness? Yes ^a _____ No _____	
External coating? No _____ Yes _____ If yes, type _____	
Internal coating? No _____ Yes _____ If yes, type _____	
Flange bolting requirements (Table 16)	Nonexposed _____ Exposed _____ Exposed (low strength) _____
Main run (studs): _____	(nuts): _____
Outlet inboard (studs): _____	(nuts): _____
Outlet other (studs): _____	(nuts): _____
Test and auxiliary equipment:	
Wear bushing: _____	
Running and retrieving tools: _____	
Test plug: _____	
Other requirements: _____	
FOOTNOTE	
^a If yes, specify what and by whom.	

Figure B.2—Wellhead Equipment Data Sheet—Casing-head Housing

Wellhead Equipment Data Sheet—Casing-head Spool	
Casing-head spool	PSL: _____ PR: _____
Bottom connector:	Size: _____ Rated working pressure: _____ Type: _____
Top connector:	Size: _____ Rated working pressure: _____ Type: _____
Outlets:	Size: _____ Rated working pressure: _____ Type: _____ Number: _____
Equipment for outlets:	Valve-removal plug: _____ Valves (right): Qty _____ Typ _____ PSL _____ PR _____ Valves (left): Qty _____ Typ _____ PSL _____ PR _____ Companion flanges: Qty _____ Typ _____ PSL _____ Bullplugs: Qty _____ Nipples: Qty _____ Needle valves: Qty _____ Gauges: Qty _____
Lock screws? Yes _____ No _____	Lock screw function: _____
Special material requirements:	_____
Bottom casing spool packoff size:	_____
	Type: _____ PR: _____
Casing hanger:	Size: _____ Type: _____ PSL: _____ PR: _____
Temperature rating (Table 2):	_____
Material class (Table 3):	_____
Retained fluid corrosivity (Table B.1):	_____
Witness? Yes ^a _____ No _____	
External coating? No _____ Yes _____	If yes, type _____
Internal coating? No _____ Yes _____	If yes, type _____
Flange bolting requirements (Table 16)	Exposed _____ Nonexposed _____
Outlet inboard (studs): _____	(nuts): _____
Outlet other (studs): _____	(nuts): _____
Test and auxiliary equipment:	
Wear bushing:	_____
Running and retrieving tools:	_____
Test plug:	_____
Other requirements:	_____
FOOTNOTE	
^a If yes, specify what and by whom.	

Figure B.3—Wellhead Equipment Data Sheet—Casing-head Spool

Wellhead Equipment Data Sheet—Tubing-head Spool	
Tubing-head spool	PSL: _____ PR: _____
Bottom connector:	Size: _____ Rated working pressure: _____ Type: _____
Top connector:	Size: _____ Rated working pressure: _____ Type: _____
Outlets:	Size: _____ Rated working pressure: _____ Type: _____ Number: _____
Equipment for outlets:	Valve-removal plug: _____ Valves (right): Qty _____ Typ ____ PSL ____ PR ____ Valves (left): Qty _____ Typ ____ PSL ____ PR ____ Companion flanges: Qty ____ Typ _____ PSL _____ Bullplugs: Qty _____ Nipples: Qty _____ Needle valves: Qty _____ Gauges: Qty _____
Lock screws? Yes _____ No _____	Lock screw function: _____
Material requirements: _____	
Bottom tubing spool packoff:	Size: _____ Type: _____ PR: _____
Tubing hanger:	Size: _____ Type: _____ PSL: _____ PR: _____ Back-pressure valve type: _____ Surface-controlled subsurface valve control lines: _____
Temperature rating (Table 2): _____	
Material class (Table 3): _____	
Retained fluid corrosivity (Table B.1): _____	
Witness? Yes ^a _____ No _____	
External coating? No _____ Yes _____ If yes, type _____	
Internal coating? No _____ Yes _____ If yes, type _____	
Flange bolting requirements (Table 16) Nonexposed _____ Exposed _____ Exposed (low strength) _____	
Main run (studs): _____ (nuts): _____	
Outlet inboard (studs): _____ (nuts): _____	
Outlet other (studs): _____ (nuts): _____	
Test and auxiliary equipment:	
Wear bushing: _____	
Running and retrieving tools: _____	
Test plug: _____	
Other requirements: _____	
FOOTNOTE	
^a If yes, specify what and by whom.	

Figure B.4—Wellhead Equipment Data Sheet—Tubing-head Spool

Wellhead Equipment Data Sheet—Crossover Flange	
Crossover flange	PSL: _____ PR: _____
Bottom connector:	Size: _____ Rated working pressure: _____ Type: _____
Top connector:	Size: _____ Rated working pressure: _____ Type: _____
Packoff type: _____	Size: _____
Temperature rating (Table 2): _____	
Material class (Table 3): _____	
Retained fluid corrosivity (Table B.1): _____	
Witness? Yes ^a _____ No _____	
External coating? No _____ Yes _____ If yes, type _____	
Internal coating? No _____ Yes _____ If yes, type _____	
Flange bolting requirement (Table 16) Nonexposed _____ Exposed _____ Exposed (low strength) _____	
Main run (studs): _____ (nuts): _____	
FOOTNOTE	
^a If yes, specify what and by whom.	

Figure B.5—Wellhead Equipment Data Sheet—Crossover Flange

Wellhead Equipment Data Sheet—Tubing-head Adapter	
Tubing-head adapter	PSL: _____ PR: _____
Bottom connector:	Size: _____ Rated working pressure: _____ Type: _____
Top connector:	Size: _____ Rated working pressure: _____ Type: _____
Surface-controlled subsurface safety valve outlets: _____	
Number: _____	
Size: _____	
Electrical feed-through connection? _____	
Special material requirements: _____	
Temperature rating (Table 2): _____	
Material class (Table 3): _____	
Retained fluid corrosivity (Table B.1): _____	
Witness? Yes ^a _____ No _____	
External coating? No _____ Yes _____ If yes, type _____	
Internal coating? No _____ Yes _____ If yes, type _____	
Flange bolting requirement (Table 16) Nonexposed _____ Exposed _____ Exposed (low strength) _____	
Main run (studs): _____ (nuts): _____	
FOOTNOTE	
^a If yes, specify what and by whom.	

Figure B.6—Wellhead Equipment Data Sheet—Tubing-head Adapter

Wellhead Equipment Data Sheet—Tree and Choke									
Tree	Single <input type="checkbox"/>	Dual <input type="checkbox"/>	Solid block <input type="checkbox"/>	Stacked <input type="checkbox"/>					
		Size	Material ^a	PSL	PR	Witness? ^b	External coating? If yes, state type	Flanged bolting requirements ^c Studs Nuts	Ring gasket type
Lower master valve: _____									
Upper master valve: _____									
Swab (crown) valve: _____									
Wing valve—inboard: _____									
Wing valve(s)—other: _____									
Tee/cross (circle one): _____									
Choke: _____									
End flange: _____									
Companion flanges: _____									
Instrument flanges: _____									
Tree cap/top conn.: _____									
Rated working pressure: _____									
Retained fluid corrosivity (Table B.1): _____									
Temperature rating (Table 2): _____									
Material class (Table 3): _____									
Upper master prepared for actuator:				Yes <input type="checkbox"/>	No <input type="checkbox"/>	If yes, specify Class I, II, or III below PR column			
Wing valve—inboard prepared for actuator:				Yes <input type="checkbox"/>	No <input type="checkbox"/>	If yes, specify Class I or II below PR column			
Wing valve—other prepared for actuator:				Yes <input type="checkbox"/>	No <input type="checkbox"/>	If yes, specify Class I or II below PR column			
Choke: adjustable or fixed: _____									
Orifice size: _____					Nominal size: _____				
Pressure drop: _____									
Flowline connector:		Size: _____							
		Type: _____							
Special material requirements: _____									
Other requirements:									
Upper master valve type actuator requirements:				Pneu./piston _____		Hydr./piston _____		Electric _____	
Supply pressure/power: _____				Pneu./diaphragm _____		Hydr./diaphragm _____		Electric _____	
Air _____ Gas _____									
Wing valve type actuator requirements:				Pneu./piston _____		Hydr./piston _____		Electric _____	
				Pneu./diaphragm _____		Hydr./diaphragm _____		Electric _____	
Supply pressure: _____									
Other: _____									

FOOTNOTES									
^a Define or specify material requirements and, if cladding or other corrosion-resistant materials are to be inlaid, state base material type/clad material type, e.g. 4130/625.									
^b If yes, specify what and by whom.									
^c Indicate required bolting for the applicable retained fluid and temperature class specified in Table 17.									

Figure B.7—Wellhead Equipment Data Sheet—Tree and Choke

Wellhead Equipment Data Sheet—Multistage Crossover Spool	
Multistage crossover spool	PSL: _____ PR: _____
Bottom connector:	Size: _____
	Rated working pressure: _____
	Type: _____
Outlets lower:	Size: _____
	Rated working pressure: _____
	Type: _____
	Number: _____
Equipment for lower outlets:	Valve-removal plug: _____
	Valves (right): Qty: _____ Typ: _____ PSL: _____ PR: _____
	Valves (left): Qty: _____ Typ: _____ PSL: _____ PR: _____
	Companion flanges: Qty _____ PSL: _____
	Bullplugs: Qty _____
	Nipples: Qty _____
	Needle valves: Qty _____
	Gauges: Qty _____
Outlets upper:	Size: _____
	Rated working pressure: _____
	Type: _____
	Number: _____
Equipment for upper outlets:	Valve-removal plug: _____
	Valves (right): Qty: _____ Typ: _____ PSL: _____ PR: _____
	Valves (left): Qty: _____ Typ: _____ PSL: _____ PR: _____
	Companion flanges: Qty _____ PSL: _____
	Bullplugs: Qty _____
	Nipples: Qty _____
	Needle valves: Qty _____
	Gauges: Qty _____
Top connector:	Size: _____
	Rated working pressure: _____
	Type: _____
Special material requirements:	_____
Temperature rating (Table 2):	_____
Material class (Table 3):	_____
Retained fluid corrosivity (Table B.1):	_____
Lock screws? Yes _____ No _____	Lock screw function: _____

Figure B.8—Wellhead Equipment Data Sheet—Multistage Crossover Spool

Wellhead Equipment Data Sheet—Multistage Crossover Spool (continued)	
Casing hanger (lower):	Size: _____
	Type: _____
	PR: _____
	PSL: _____
Restricted-area packoff (lower):	Size: _____
	Type: _____
Temperature rating (Table 2):	_____
Material class (Table 3):	_____
Retained fluid corrosivity (Table B.1):	_____
Casing hanger (upper):	Size: _____
	Type: _____
	PR: _____
	PSL: _____
Restricted-area packoff (upper)	Size: _____
	Type: _____
Temperature rating (Table 2):	_____
Material class (Table 3):	_____
Retained fluid corrosivity (Table B.1):	_____
Flange bolting requirements (Table 16)	Nonexposed _____ Exposed _____ Exposed (low strength) _____
Outlet lower (studs): _____	(nuts): _____
Outlet upper (studs): _____	(nuts): _____
Main run (studs): _____	(nuts): _____
Other requirements:	_____
Witness? No _____ Yes ^a _____	
External coating? No _____ Yes _____	If yes, type: _____
Internal coating? No _____ Yes _____	If yes, type: _____
Test and auxiliary equipment: (top and/or bottom)	_____
Wear bushings:	_____
Running and retrieving tools:	_____
Test plugs:	_____
Other requirements:	_____
FOOTNOTE	
^a If yes, specify what and by whom.	

Figure B.8—Wellhead Equipment Data Sheet—Multistage Crossover Spool (continued)

Wellhead Equipment Data Sheet—Wellhead Safety Valves	
Wellhead safety valves	
General	
Special environmental conditions _____	Unusual ambient or operating temperatures, or atmospheric conditions conducive to corrosion or underwater use
Coating _____	
Shipping instructions _____	
SSV/USV valve	
(Class I, II, or III SSV/USV) _____	
Manufacturer _____	Model and type _____
Size _____	
Rated working pressure _____	
Temperature range _____	
SSV/USV actuator	
Manufacturer _____	Model and type _____
Cylinder rated working pressure _____	
Operating pressure _____	Purchaser to specify available supply pressure, if applicable
Temperature range _____	
Lock-open device _____	
USV _____	Working water depth _____

Figure B.9—Wellhead Equipment Data Sheet—Wellhead Safety Valves

Equipment Data Sheet—Boarding Shutdown Valves	
General	
Special environmental conditions _____	Unusual ambient or operating temperatures, or atmospheric conditions conducive to corrosion, or use in the offshore splash zone
Coating _____	
Shipping instructions _____	
BSDV valve	
(Class I, II, or III BSDV) _____	
Manufacturer _____	Model and type _____
Size _____	
Rated working pressure _____	
Temperature range _____	
BSDV actuator	
Manufacturer _____	Model and type _____
Cylinder rated working pressure _____	
Operating pressure _____	Purchaser to specify available supply pressure, if applicable
Temperature range _____	

Figure B.10—Equipment Data Sheet—Boarding Shutdown Valves

Wellhead Equipment Data Sheet—Choke Sizing				
Application				
Fluid				
Quantity				
End connectors/A&B Dimensions ^a				
Pressure rating/inlet			Outlet	
Temperature rating				
Material class		Body	Trim	
PSL		PR		
Service conditions at		Max. flow (units)	Normal flow (units)	Min. flow (units)
Pressure	Inlet			
	Outlet or ΔP			
Temperature at inlet				
Oil	Flow rate			
	S.G. (if available)			
Gas	Flow rate			
	or G.O.R.			
	S.G. (if available)			
Liquid	Flow rate			
	S.G. (if available)			
Manual/actuated				
Actuator type/make/model				
Power source				
Manual override				
Position indication	Local		Remote/position transmitter	
Positioner				
Additional comments				
Adjustable or positive:				
Maximum orifice diameter:				
Type of flow bean:				
FOOTNOTE				
^a See Figure 16 and Figure 17.				

Figure B.11—Wellhead Equipment Data Sheet—Choke Sizing

Wellhead Equipment Data Sheet—Actuator and Bonnet					
Pneumatic Diaphragm _____ Single _____ Double _____ Piston _____ Single _____ Double _____	Quantity _____	Hydraulic Conventional _____ Rising stem _____ Nonrising stem _____ Wirecutter _____ Self-contained _____	Quantity _____	Electric _____ _____ Wire/cable size _____ Stand-alone power source _____	Quantity _____
Supply requirements/specifications					
Pneumatic Availability _____ MPa (psi) Max. _____ Min. _____ Clean air _____ Nitrogen _____ Other _____			Hydraulic Availability _____ MPa (psi) Max. _____ Min. _____ Self-contained _____ Other _____		
Electric Voltage _____ DC _____ AC _____ Phase _____ Frequency _____ Current available _____ Other _____					
Actuator requirements/specifications			Field data		
Actuator Temperature rating (Table 2) _____ Materials class (Table 3) _____ External coating? No _____ Yes _____ If yes, type _____			Customer _____ Field location _____ Platform _____ Well No. _____ Closed-in tubing-head pressure _____ MPa (psi)		
			Accessories Fusible hold-open device _____ Manual hold-open device _____ Quick exhaust valve _____ Position indication a) local _____ b) remote _____		
Bonnet requirements					
Size _____		Specification		PSL	
Model _____		SSV/USV/BSVDV _____		2 _____	
Rated working pressure _____ MPa (psi)		PR2 _____		3 _____	
				3G _____	
				4 _____	
Material class: _____			Temperature rating: _____		

Figure B.12—Wellhead Equipment Data Sheet—Actuator and Bonnet

B.3 Typical Wellhead and Tree Configurations

Examples of typical wellhead and tree configurations are shown in Figure B.13 and Figure B.14. Also included are examples of casing and bit programs that are consistent with the wellheads shown.

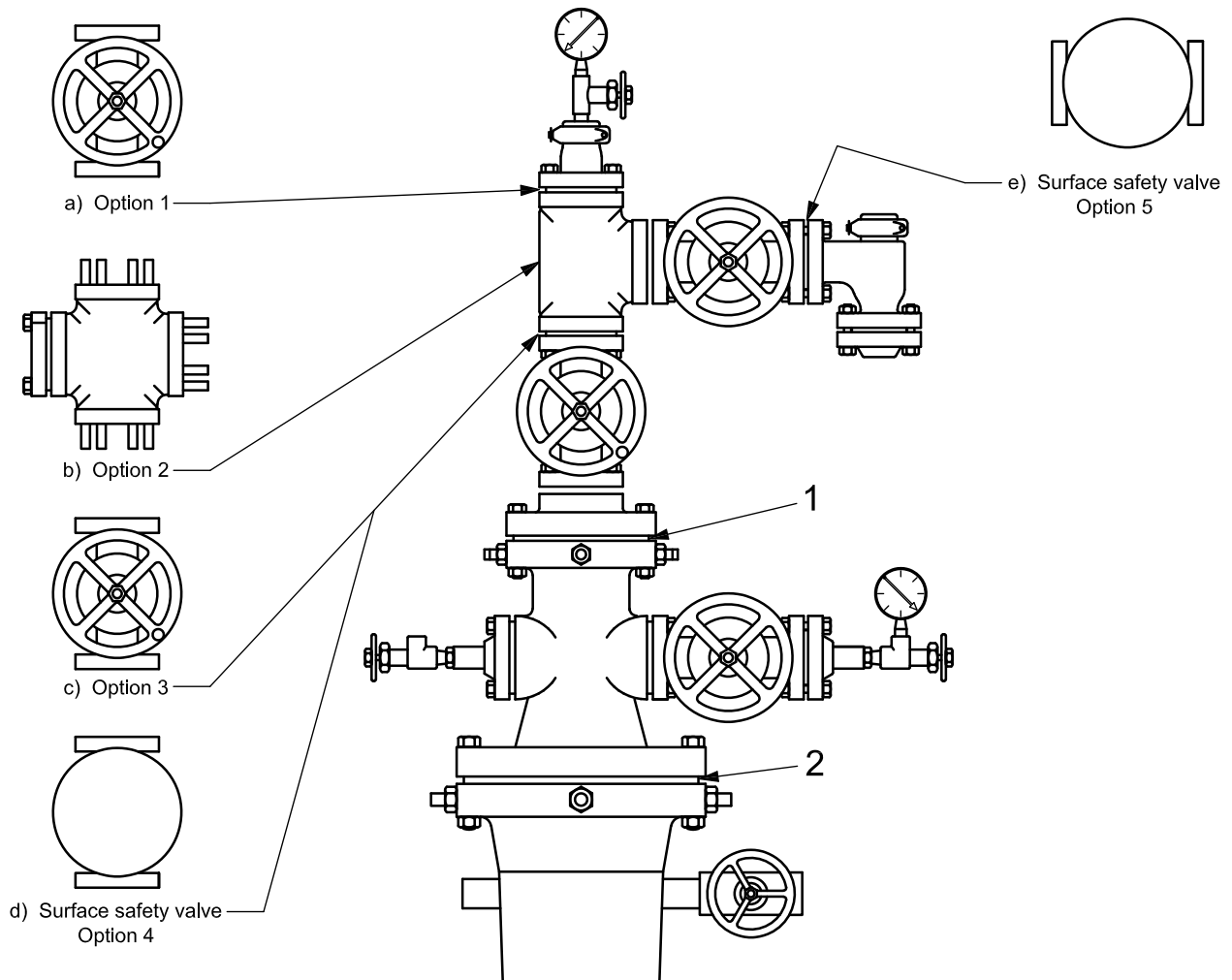

Key

- 1 tubing-head top flange 34.5 MPa (5000 psi)
- 2 casing-head top flange 20.7 MPa (3000 psi) or 34.5 MPa (5000 psi)

Typical Programs			
Casing Program mm (in.)	Bit Program mm (in.)	Casing-head Top Flange mm; MPa (in.; psi)	Tubing-head Top Flange mm; MPa (in.; psi)
219.1 (8 ⁵ / ₈) x 139.7 (5 ¹ / ₂)	200.0 (7 ⁷ / ₈)	279; 20.7 (11; 3000)	179; 34.5 (7 ¹ / ₁₆ ; 5000)
244.5 (9 ⁵ / ₈) x 177.8 (7)	215.9 (8 ¹ / ₂) or 222.2 (8 ³ / ₄)	or	
273.1 (10 ³ / ₄) x 193.7 (7 ⁵ / ₈)	250.8 (9 ⁷ / ₈)	279; 34.5 (11; 5000)	

Figure B.13—Typical Wellhead and Tree Configuration for a 34.5 MPa (5000 psi) Rated Working Pressure

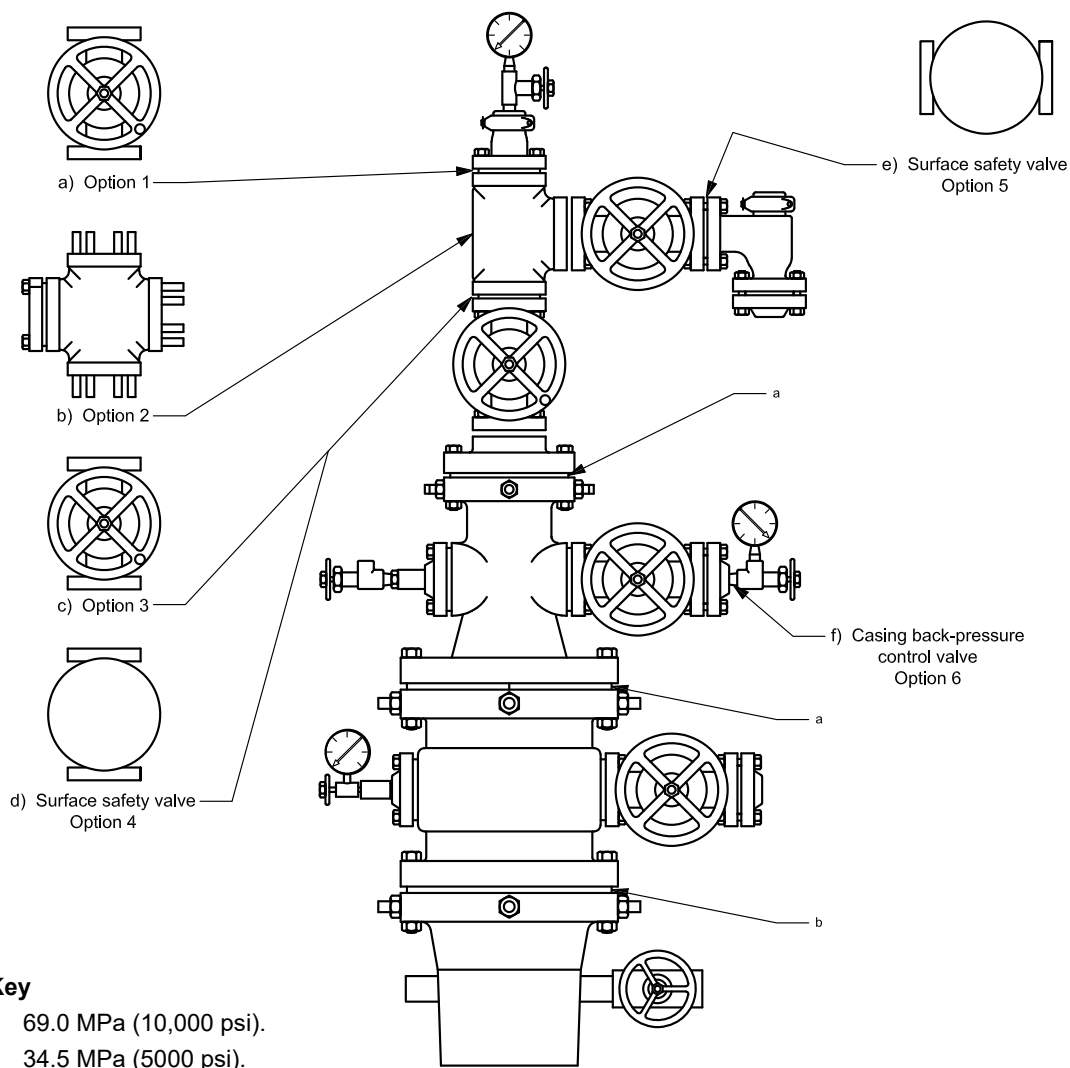

Typical Programs				
Casing Program mm (in.)	Bit Program mm (in.)	Casing-head Housing Top Flange mm; MPa (in., psi)	Casing-head Spool Top Flange mm; MPa (in., psi)	Tubing-head Top Flange mm; MPa (in., psi)
406.4 x 273.1 x 193.7 (16 x 10 ³ / ₄ x 7 ⁵ / ₈)	374.7 x 250.8 or 241.3 (14 ³ / ₄ x 9 ⁷ / ₈ or 9 ¹ / ₂)	425; 34.5 (16 ³ / ₄ ; 5000)	279; 69.0 (11; 10,000)	179; 69.0 (7 ¹ / ₁₆ ; 10,000)
406.4 x 298.5 x 244.5 x 177.8 liner (16 x 11 ³ / ₄ x 9 ⁵ / ₈ x 7) liner	374.7 x 269.9 x 215.9 (14 ³ / ₄ x 10 ⁵ / ₈ x 8 ¹ / ₂)	425; 34.5 (16 ³ / ₄ ; 5000)	346; 69.0 (13 ⁵ / ₈ ; 10,000) 279; 69.0 (11; 10,000)	179; 69.0 (7 ¹ / ₁₆ ; 10,000)
339.7 x 244.5 x 177.8 (13 ³ / ₈ x 9 ⁵ / ₈ x 7)	311.2 x 215.9 x 152.4 (12 ¹ / ₄ x 8 ¹ / ₂ x 6)	346; 34.5 (13 ⁵ / ₈ ; 5000)	279; 69.0 (11; 10,000)	179; 69.0 (7 ¹ / ₁₆ ; 10,000)
273.1 x 193.7 x 127.0 (10 ³ / ₄ x 7 ⁵ / ₈ x 5)	250.8 x 165.1 (9 ⁷ / ₈ x 6 ¹ / ₂)	279; 34.5 (11; 5000)	279; 69.0 (11; 10,000)	179; 69.0 (7 ¹ / ₁₆ ; 10,000)

Figure B.14—Typical Wellhead and Tree Configuration for a 69.0 MPa (10,000 psi) Rated Working Pressure

B.4 Product Specification Levels

B.4.1 General

This specification establishes requirements for four PSLs. These four PSLs are independent of verification and validation of a product and define different levels of manufacturing requirements. Equipment with a PSL has specific quality control, material, and testing requirements for equipment covered by this specification (see 4.3.4).

PSL 1 represents the set of basic or minimum requirements for quality, material, and testing. All products to which a PSL applies minimally satisfy PSL 1 requirements for conformance with this specification. Higher level PSLs may be applied to the equipment by the manufacturer or may be specified by the purchaser, based on intended use of the equipment. SSVs, USVs, and BSDVs cannot be PSL 1.

PSL 2 contains all the quality and testing requirements of PSL 1 but imposes additional requirements as detailed in this specification. BSDVs cannot be PSL 2. The additional requirements include limitations to variance between the material QTC and the production material. It includes requirements for Charpy testing for service temperature -20°F and below, volumetric inspection of welds, and magnetic particle inspection of accessible well wetted surfaces.

PSL 3 contains all the quality and testing requirements of PSL 2 but imposes additional requirements as detailed in this specification. The additional requirements include restricted tolerance of material chemistry, changes to the material QTC in relation to the section thickness of the equipment parts. It includes Charpy testing for all service temperatures; volumetric inspection of all material in body, bonnets, flanges, and stems; wet magnetic particle inspection of all accessible surfaces; and extended hydrostatic test times.

NOTE The designation “PSL 3G” contains the same quality and testing requirements of PSL 3 with the addition of gas testing; end connectors and hangers do not require gas testing, so PSL 3G does not apply.

PSL 4 contains the highest level of quality and testing requirements for any product within this specification. PSL 4 equipment meets all the requirements of PSL 3 and would apply to high-pressure equipment used in sour service.

Figure B.15 shows the recommended specification level for primary equipment. Primary equipment of a wellhead assembly includes the following, as a minimum:

- tubing head;
- tubing hanger;
- tubing-head adapter;
- lower master valve.

All other wellhead parts are classified as secondary. The specification level for secondary equipment may be different than the level for primary equipment.

The selection of a PSL should be based on a quantitative risk analysis, which is a formal and systematic approach to identifying potentially hazardous events and estimating the likelihood and consequences to people, environment, and resources, of accidents developing from these events.

The following comments apply to the basic questions asked in Figure B.15.

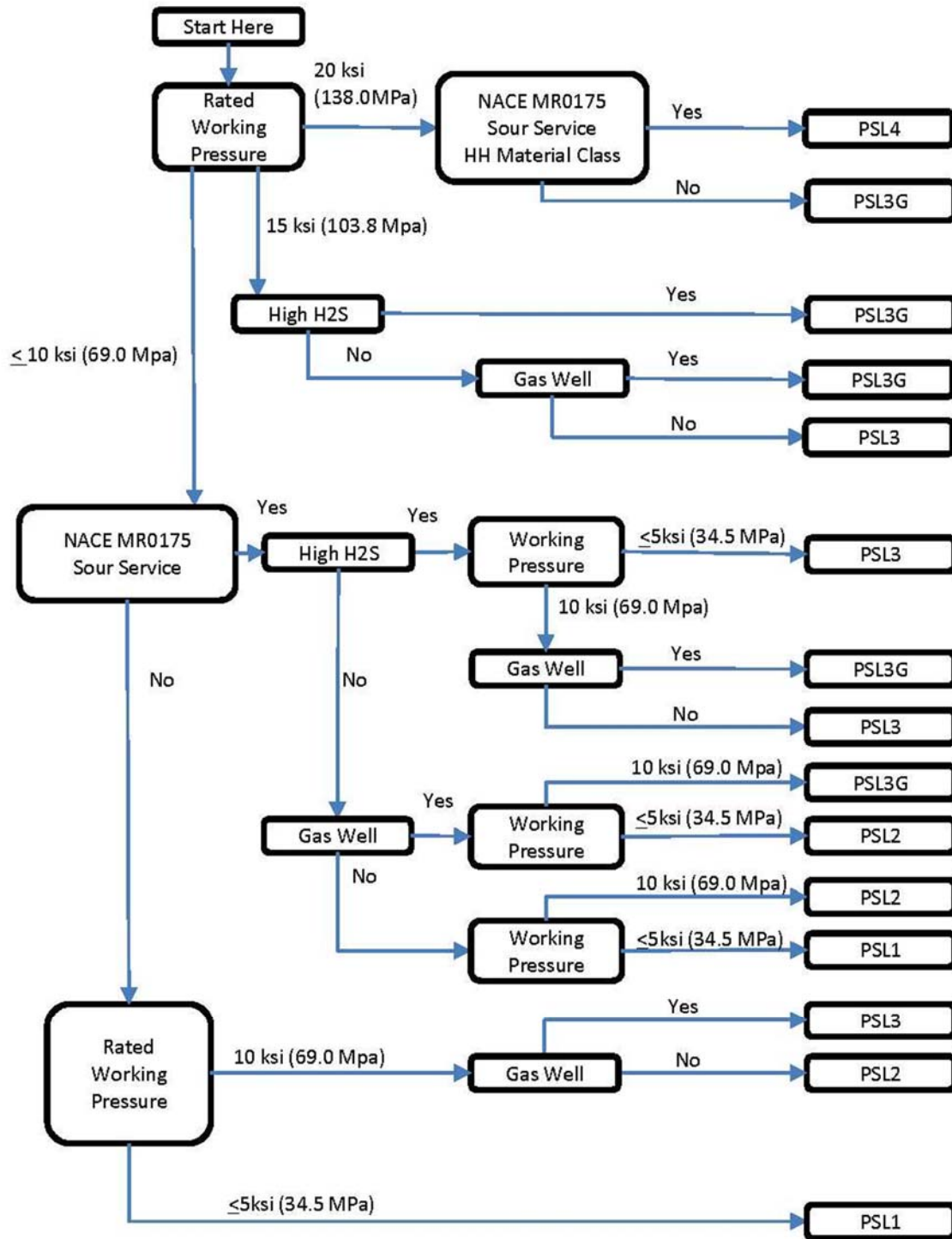

Figure B.15—Recommended Minimum PSL for Primary Parts

B.4.2 NACE MR0175/ISO 15156

This applies if the partial pressure of H₂S in the produced fluid equals or exceeds the minimum amount specified by NACE MR0175/ISO 15156 for sour service.

B.4.3 High H₂S Concentration

Use “Yes” if the H₂S concentration of the produced fluid is such that in air an H₂S concentration of 70 ml/m³ [70 ppm (parts per million)] can develop in case of a leak (human sense of smell cannot detect concentrations higher than 70 ml/m³).

Alternatively, use “Yes” if the radius of exposure (ROE) to 100 ml/m³ (100 ppm) H₂S is greater than 15 m (50 ft) from the wellhead. ROE is defined in Texas Administrative Code, Title 16, Part 1, Chapter 3, Rule 3.36, b) 3); see B.4.5. Other methods of calculating ROE may apply, depending on local regulations.

The above requires the knowledge of the adjusted open flow rate of offset wells. If this is not available, but if H₂S can be expected, a 100 ml/m³ (100 ppm) ROE equal to 1000 m (3000 ft) may be assumed.

B.4.4 Close Proximity

Users who are accustomed to the use of the close-proximity and radius-of-exposure concepts may substitute close-proximity for gas well in Figure B.15.

The potential impact of an uncontrolled emission of H₂S on life and the environment near the wellhead should be evaluated as part of the proximity assessment. The following list of items can be used for determining potential risk.

- a) 100 ml/m³ (100 ppm) ROE of H₂S is greater than 15 m (50 ft) from the wellhead and includes any part of a public area except a public road. ROE is defined in B.4.5. “Public area” means a dwelling, place of business, place of worship, school, hospital, school bus stop, government building, a public road, all or any portion of a park, city, town, village, or other similar area that one can expect to be populated. “Public road” means any street or road owned or maintained for public access or use.
- b) 500 ml/m³ (500 ppm) ROE of H₂S is greater than 15 m (50 ft) from the wellhead and includes any part of a public area as well as a public road.
- c) Well is located in any environmentally sensitive area, such as a park, wildlife preserve, city limits, etc.
- d) Well is located within 46 m (150 ft) of an open flame or fired equipment.
- e) Well is located within 15 m (50 ft) of a public road.
- f) Well is located in or near inland navigable waters.
- g) Well is located in or near surface domestic water supplies.
- h) Well is located within 107 m (350 ft) of any dwelling.

These conditions are recommended minimum considerations. Any local regulatory requirements should be met.

B.4.5 Radius of Exposure of H₂S

The following information is taken from Texas Railroad Commission Rule 36. SI metric-equivalent rules are not given, as the method of determining the ROE is used in the United States only. Other methods of calculating ROE may apply, depending on local regulations.

The location, X_{100} , of the 100 ml/m³ (100 ppm) ROE is determined as given in Equation (B.1):

$$X_{100} = [(1.589)(y_{H_2S})(q)]^{0.6258} \quad (B.1)$$

The location, X_{500} , of the 500 ml/m³ (500 ppm) ROE is determined as given in Equation (B.2):

$$X_{500} = [(0.4546)(y_{H_2S})(q)]^{0.6258} \quad (B.2)$$

where

y_{H_2S} is the mole fraction H₂S in the gaseous mixture available for escape;

X is ROE, expressed in feet;

q is the maximum volume flow rate determined to be available for escape, expressed in cubic feet per day.

The volume flow rate used as the escape rate in determining the ROE shall be that specified below, as applicable.

- a) For new wells in developed areas, the escape rate shall be determined by using the current-adjusted open flow rate of offset wells, or the field-average current-adjusted open flow rate, whichever is larger.
- b) The escape rate used in determining the ROE shall be corrected to standard conditions of 0.101 MPa (14.65 psia) and 16 °C (60 °F).

B.5 Corrosivity of Retained Fluid

To select the desired material class in Table 3, the purchaser should determine the corrosivity of the retained, produced, or injected fluid by considering the various environmental factors and production variables listed in Figure B.1. General corrosion, SCC, erosion-corrosion, and sulfide stress cracking (SSC) are all influenced by the interaction of the environmental factors and the production variables. Other factors and variables not listed in Figure B.1 may also influence fluid corrosivity.

The purchaser should determine whether materials shall meet NACE MR0175/ISO 15156 for sour service. NACE MR0175/ISO 15156 is concerned only with the metallic material requirements to prevent SSC and not with resistance to general corrosion. The impact of the partial pressure of carbon dioxide should be assessed, which generally relates to corrosivity in wells, as shown in Table B.1. This table is a guideline only.

Analysis of produced fluids might not predict the field performance of metallic or nonmetallic material.

The minimum partial pressure of carbon dioxide required to initiate corrosion and the relative effect of increasing partial pressures on the corrosion rate are strongly influenced by other environmental factors and production variables, such as:

- a) temperature;
- b) H₂S level;
- c) pH;
- d) chloride ion concentration;
- e) sand production;
- f) water production and composition;
- g) types and relative amounts of produced hydrocarbons.

Table B.1—Relative Corrosivity of Retained Fluids as Indicated by CO₂ Partial Pressure

Retained Fluids	Relative Corrosivity	Partial Pressure of CO ₂	
		MPa	psia
General service	Noncorrosive	< 0.05	< 7
General service	Slightly corrosive	0.05 to 0.21	7 to 30
General service	Moderately to highly corrosive	> 0.21	> 30
Sour service	Noncorrosive	< 0.05	< 7
Sour service	Slightly corrosive	0.05 to 0.21	7 to 30
Sour service	Moderately to highly corrosive	> 0.21	> 30

Finally, the purchaser should consider future service of the well when selecting a material class. Future servicing needs should include evaluation of anticipated changes in the acid-gas partial pressures for production or increased water production with or without increased chloride content. It also should include anticipated operations such as acidification or other well treatments.

B.6 Use of Castings

Purchaser should evaluate the use and requirements of cast, pressure-containing parts for an application. The manufacturing methods for forging (wrought) and castings may produce differences in performance, quality, grain structure, and corrosion resistance for the same PSL. However, castings may be beneficial for parts of large size or complex shape.

Castings inherently have more problems with porosity, cavities, and inclusions. The hot working practices of wrought parts close porosity and cavities. Additionally, grain structure is improved by hot work. Grain structure can affect corrosion and toughness of the part. Specifying PSL 2 or PSL 3 will enable application of standard surface and volumetric inspections of castings for intended service.

Purchasers may limit applications or increase the PSL for a cast part as deemed appropriate for the equipment's classification (primary/secondary) or service conditions. Table B.2 provides an application guide for pressure-containing parts based on equipment classification and service conditions.

B.7 Fire Testing

When fire resistance qualification of equipment in this specification is required, qualification in accordance with API 6FA (for gate, plug, and ball valves), API 6FB (for OECs) or API 6FD (for check valves) should be specified or as agreed to between the manufacturer and the purchaser.

Table B.2—Recommended Service Limits for Castings

Rated Working Pressure	Material Class		
	AA, BB, CC	DD, EE, FF	HH
13.8 MPa (2000 psi)	Wrought or cast	Wrought or cast	Wrought or cast
20.7 MPa (3000 psi)	Wrought or cast	Wrought or cast	Wrought or cast
34.5 MPa (5000 psi)	Wrought or cast	Wrought or cast	Wrought or cast
69.0 MPa (10,000 psi)	Wrought or cast	Wrought	Wrought
103.5 MPa (15,000 psi)	Wrought	Wrought	Wrought
138.0 MPa (20,000 psi)	Wrought	Wrought	Wrought
FOOTNOTE See Table 5 for minimum PSL and Figure B.15 for additional PSL guidance.			

Annex C (informative)

Conversion Procedures—Units of Measure

C.1 General Information

C.1.1 General

These conversion procedures are changed from previous editions. There are two significant conversion changes that affected many dimensions specified in millimeters.

- a) The inch dimensions with fractional origin are not converted from the exact decimal equivalent, but from the decimal-format value specified in this edition. For example, 2.56 in. are converted just as written: $2.56 \text{ in.} \times 25.4 = 65.0 \text{ mm}$, whereas previous editions converted as follows:

$$2.56 \text{ in.} \Rightarrow 2^{9/16} \text{ in.} = 2.5625 \text{ in.} = 2.5625 \text{ in.} \times 25.4 = 65.1 \text{ mm.}$$

- b) Rounding rules for SI dimensions were revised to reduce variations in geometry between equipment. For example, flange ODs are now rounded to 1 mm instead of 5 mm.

C.1.2 Conversion Rules

The dimensions in SI units were obtained by converting from dimensional tables of API 6A in accordance with the following procedures. The conversion is illustrated in the following example.

- a) Multiply the published decimal value or the decimal equivalent of a fractional-inch dimension by 25.4 mm/in. to obtain the exact millimeter dimension.

EXAMPLE $4.31 \text{ in.} \times 25.4 = 109.474 \text{ mm.}$

NOTE The period is always used as the decimal sign.

- b) Then, do the rounding indicated for the particular dimension. Rounding rules may vary for different dimensions, depending on the application of the dimension.

EXAMPLE

- If the above dimension were to be rounded to the nearest even 5 mm, the resulting dimension would be 110 mm.
- If the above dimension were to be rounded to the accuracy nearest to the inch dimension, that would be XXX.X mm, and the resulting dimension would be 109.5 mm.

C.2 6B and 6BX Flanges and Studded Outlets

C.2.1 Pressure Ratings

The selected ratings in megapascals have been converted from the dimensional tables of API 6A in such a way as to preserve the ratio of pressure ratings, expressed in pounds per square inch, while still using convenient simple numbers, as given in Table C.1.

Table C.1—Pressure Rating Conversion between SI and USC for API 6A Equipment

Megapascals (MPa)	Pounds per Square Inch (psi)
13.8	2000
20.7	3000
34.5	5000
69.0	10,000
103.5	15,000
138.0	20,000

C.2.2 Nominal Sizes

Nominal bore sizes for flanges and studded outlets in this specification are expressed in USC unit values only. The nominal size is for identification purposes and is not a manufacturing dimension.

C.2.3 Rounding Rules

The following rules were used to develop flange dimensions.

- a) For the maximum bore, round to the nearest 0.1 mm.

EXAMPLE 2.09 in. \Rightarrow 53.086 mm \Rightarrow 53.1 mm.

- b) For the flange OD, round to the nearest 1 mm.

NOTE This is not consistent with ANSI practice or previous editions of this specification.

EXAMPLE 8.12 in. \Rightarrow 206.248 mm \Rightarrow 206 mm.

- c) For the maximum chamfer, round to the nearest 1 mm.

EXAMPLE 0.12 in. \Rightarrow 3.048 mm \Rightarrow 3 mm;

0.25 in. \Rightarrow 6.350 mm \Rightarrow 6 mm.

- d) For the raised face diameter, round to the nearest 1 mm.
- e) For the thickness of flange, round up to the next 0.1 mm.
- f) For the hub dimensions J_1 , J_2 , J_3 , and X , round to the nearest 0.1 mm.
- g) For the radius at back face, convert as given in Table C.2.

Table C.2—Conversions for the Radius at Back Face

Millimeters	Inches
3	0.12
10	0.38
16	0.62
19	0.75
21	0.81
25	1.00

- h) For the tolerance for the bolt hole location ± 0.8 mm.
- i) For the bolt circle, round to the nearest 0.1 mm.
- j) For the bolt hole diameter, round up to the next 1 mm.

Table C.3—Rounding Values for Hole Sizes and Tolerances

Hole Size	Tolerance mm
< 42 mm	+2 −0.5
≥ 42 mm and ≤ 74 mm	+2.5 −0.5
> 74 mm	+3 −0.5

- k) For the stud lengths, round to the nearest 5 mm.
- l) Segmented flange dimensions are rounded as follows:
 - E dimension: Round to the nearest 0.1 mm;
 - F dimension: 0.12 in. becomes 3 mm;
 - K dimension: Round to the nearest 0.1 mm;
 - Q dimension: Round to the nearest 0.01 mm.
- m) For the ring gasket and groove dimensions, convert exactly to the nearest 0.01 mm except for the hole size D of the RX and BX ring joints.

C.3 Other Equipment Dimensions

C.3.1 Bore Dimensions

For the maximum or nominal bore diameter, round to the nearest 0.1 mm.

C.3.2 Valve Face-to-face Dimensions

For all valves, the dimension is rounded to the nearest 1 mm.

C.3.3 Cross and Tee Center-to-face Dimensions

These dimensions are rounded to the nearest 0.5 mm.

C.3.4 Multiple Completion Centerline Spacing

These dimensions are converted and expressed to two decimals. The resulting dimension and tolerance shall be selected so that the physical size is always within the tolerance range of ± 0.005 in. when a tolerance of ± 0.12 mm is applied.

EXAMPLE Dimension 1.390 in. from flange center, ± 0.005 in. Alternatives are as follows.

- Lower limit: 1.385 in. \Rightarrow 35.179 mm (35.18 or 35.19).
- Center: 1.390 in. \Rightarrow 35.306 mm (35.30 or 35.31).
- Upper limit: 1.395 in. \Rightarrow 35.433 mm (35.42 or 35.43).
- Choose the first center dimension 35.30 mm, since it is a round number.

C.4 Conversion Factors

C.4.1 Length

1 inch (in.) equals 25.4 millimeters (mm), exactly.

C.4.2 Pressure/Stress

1 pound-force per square inch (psi) = 0.006894757 megapascal (MPa).

1 megapascal (MPa) equals 1 newton per square millimeter (N/mm²).

NOTE 1 bar = 0.1 MPa.

C.4.3 Impact Energy

1 foot-pound (ft-lb) equals 1.355818 joule (J).

C.4.4 Torque

1 foot-pound (ft-lb) equals 1.355818 newton-meter (N-m).

C.4.5 Temperature

Degrees Celsius equals $\frac{5}{9}$ (degrees Fahrenheit minus 32).

C.4.6 Force

1 pound-force (lbf) equals 4.448222 newton (N).

C.4.7 Mass

1 pound-mass (lbm) equals 0.45359237 kilogram (kg) exactly.

Annex D (normative)

Dimensional Tables—SI Units

Table D.1—Type 6B Flanges for 13.8 MPa

Table D.2—Type 6B Flanges for 20.7 MPa

Table D.3—Type 6B Flanges for 34.5 MPa

Table D.4—Type 6BX Flanges for 69.0 MPa

Table D.5—Type 6BX Flanges for 103.5 MPa

Table D.6—Type 6BX Flanges for 138.0 MPa

Table D.7—Type 6BX Large-bore Flanges for 13.8 MPa, 20.7 MPa, and 34.5 MPa

Table D.8—Type R Ring Grooves

Table D.9—Type R Ring Gaskets

Table D.10—Type RX Ring Gaskets

Table D.11—Type BX Ring Grooves

Table D.12—Type BX Ring Gaskets

Table D.13—Flanged Crosses and Tees

Table D.14—Studded Crosses and Tees

Table D.15—Bullplugs

Table D.16—VR Plug Dimensions, 13.8 MPa, 20.7 MPa, 34.5 MPa, and 69.0 MPa

Table D.17—VR Preparation Dimensions, 13.8 MPa, 20.7 MPa, 34.5 MPa, and 69.0 MPa

Table D.18—VR Plug Thread Gauging Dimensions, 13.8 MPa, 20.7 MPa, 34.5 MPa, and 69.0 MPa

Table D.19—VR Preparation Thread Gauging Dimensions, 13.8 MPa, 20.7 MPa, 34.5 MPa, and 69.0 MPa

Table D.20—HPVR Plug Dimensions, 103.5 MPa and 138.0 MPa

Table D.21—HPVR Preparation Dimensions, 103.5 MPa and 138.0 MPa

Table D.22—Flanged Full-bore Gate Valves

Table D.23—Flanged Plug and Ball Valves

Table D.24—Flanged Swing and Lift Check Valves

Table D.25—Center Spacing of Conduit Bores for Dual Parallel Bore Valves for 13.8 MPa, 20.7 MPa, 34.5 MPa, and 69.0 MPa

Table D.26—Center Spacing of Conduit Bores for Triple, Quadruple, and Quintuple Parallel Bore Valves for 13.8 MPa, 20.7 MPa, 34.5 MPa, and 69.0 MPa

Table D.27—Maximum Hanger Outside Diameter for Wellheads

Table D.28—Minimum Vertical Full-opening Wellhead Body Bores and Maximum Casing Sizes

Table D.29—Pipe Thread Counterbore and Standoff Dimensions

Table D.30—Gauging of Casing and Tubing Threads

Table D.1—Type 6B Flanges for 13.8 MPa

Dimensions in millimeters unless noted otherwise

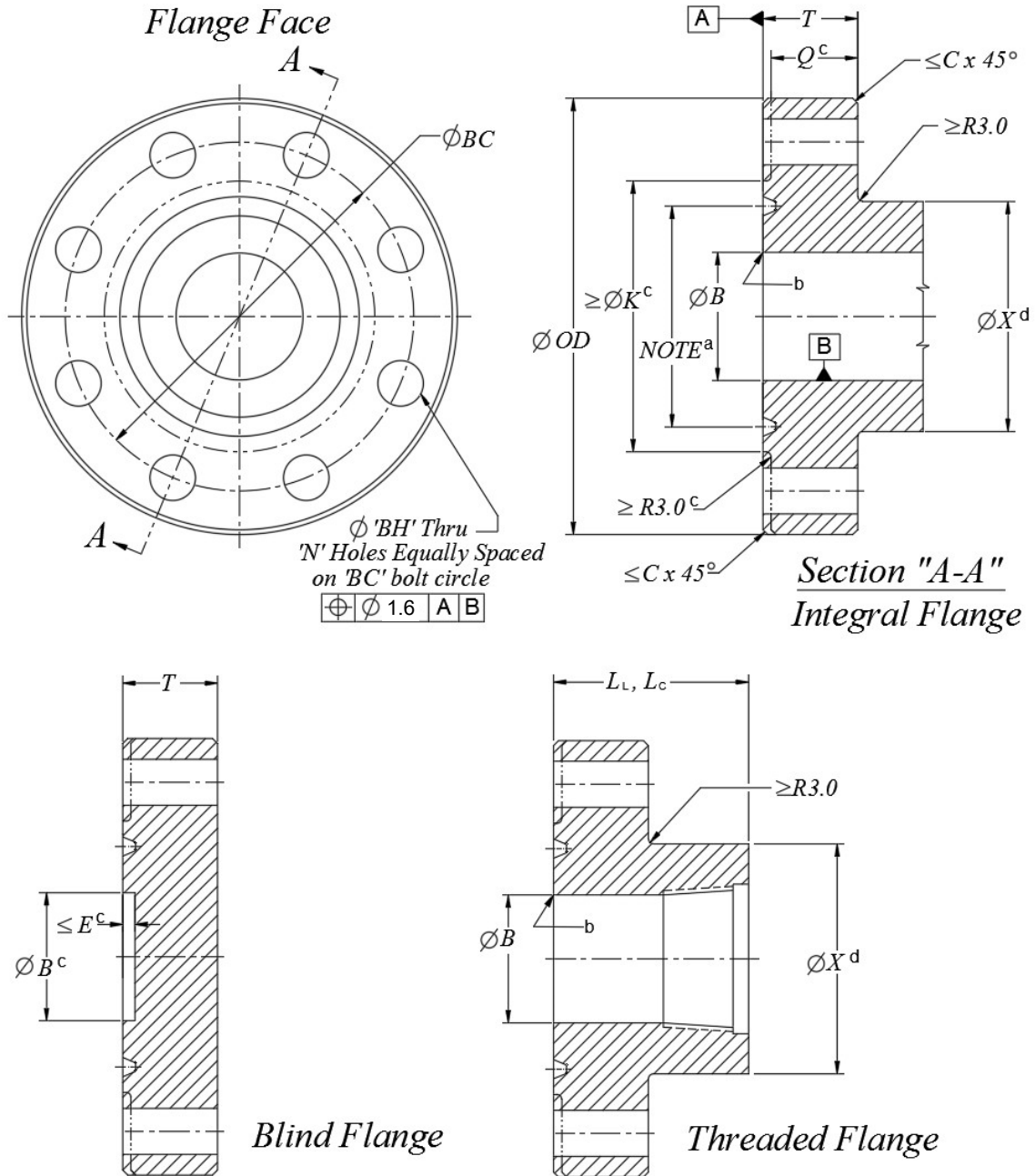

FOOTNOTES

- ^a Ring groove shall be concentric with bore B within 0.25 mm diametrical runout. See Table D.8 for ring groove dimensions.
- ^b Break sharp corner.
- ^c Raised face K and counterbore E are optional features.
- ^d Diameter X is a reference dimension.

Table D.1—Type 6B Flanges for 13.8 MPa (continued)

Dimensions in millimeters unless noted otherwise

Nominal Size of Flange ^a	Maximum Bore	Outside Diameter of Flange	Max. Chamfer	Diameter of Raised Face	Total Thickness of Flange	Basic Thickness of Flange	Diameter of Hub	Counter-bore Depth
in.	<i>B</i>	<i>OD</i>	<i>C</i>	<i>K</i>	<i>T</i>	<i>Q</i>	<i>X</i>	<i>E</i>
Tolerance>	max.	As noted	max.	min.	+3.0/-0	min.	Reference	+0.5/-0
2 ¹ / ₁₆	53.1	165 ±2	3	108	33.3	25.4	84.1	7.9
2 ⁹ / ₁₆	65.8	191 ±2	3	127	36.6	28.4	100.1	7.9
3 ¹ / ₈	81.8	210 ±2	3	146	39.6	31.8	117.2	7.9
4 ¹ / ₁₆	108.7	273 ±2	3	175	46.0	38.1	152.4	7.9
5 ¹ / ₈	131.1	330 ±2	3	210	52.3	44.5	189.0	7.9
7 ¹ / ₁₆	181.9	356 ±3	6	241	55.6	47.8	222.3	7.9
9	229.4	419 ±3	6	302	63.5	55.6	273.1	7.9
11	280.2	508 ±3	6	356	71.4	63.5	342.9	7.9
13 ⁵ / ₈	347.0	559 ±3	6	413	74.7	66.5	400.1	7.9
16 ³ / ₄	426.2	686 ±3	6	508	84.1	76.2	495.3	7.9
21 ¹ / ₄	540.5	813 ±3	6	635	98.6	88.9	609.6	9.7

FOOTNOTE

^a For flange sizes 26³/₄ in. and 30 in., see Table D.7.

Nominal Size of Flange ^a	Diameter of Bolt Circle	Number of Bolts	Bolt Size and TPI	Bolt Holes		Hub Length, Threaded Flange		Ring Groove Number
						Line Pipe Flange	Casing Flange	
in.	<i>BC</i>	<i>N</i>	in.	<i>BH</i>		<i>L_L</i>	<i>L_C</i>	
Tolerance>	See figure for GDT		(Ref.)	Diameter	Tolerance	min.	min.	
2 ¹ / ₁₆	127.0	8	5/8-11	20	+2/-0.5	44	—	R 23
2 ⁹ / ₁₆	149.4	8	3/4-10	23	+2/-0.5	49	—	R 26
3 ¹ / ₈	168.1	8	3/4-10	23	+2/-0.5	54	—	R 31
4 ¹ / ₁₆	215.9	8	7/8-9	26	+2/-0.5	62	89	R 37
5 ¹ / ₈	266.7	8	1-8	29	+2/-0.5	68	102	R 41
7 ¹ / ₁₆	292.1	12	1-8	29	+2/-0.5	75	114	R 45
9	349.3	12	1 1/8-8	32	+2/-0.5	84	127	R 49
11	431.8	16	1 1/4-8	35	+2/-0.5	94	133	R 53
13 ⁵ / ₈	489.0	20	1 1/4-8	35	+2/-0.5	100	100	R 57
16 ³ / ₄	603.2	20	1 1/2-8	42	+2.5/-0.5	114	114	R 65
21 ¹ / ₄	723.9	24	1 5/8-8	45	+2.5/-0.5	137	137	R 73

FOOTNOTE

^a For flange sizes 26³/₄ in. and 30 in., see Table D.7.

Table D.2—Type 6B Flanges for 20.7 MPa

Dimensions in millimeters unless noted otherwise

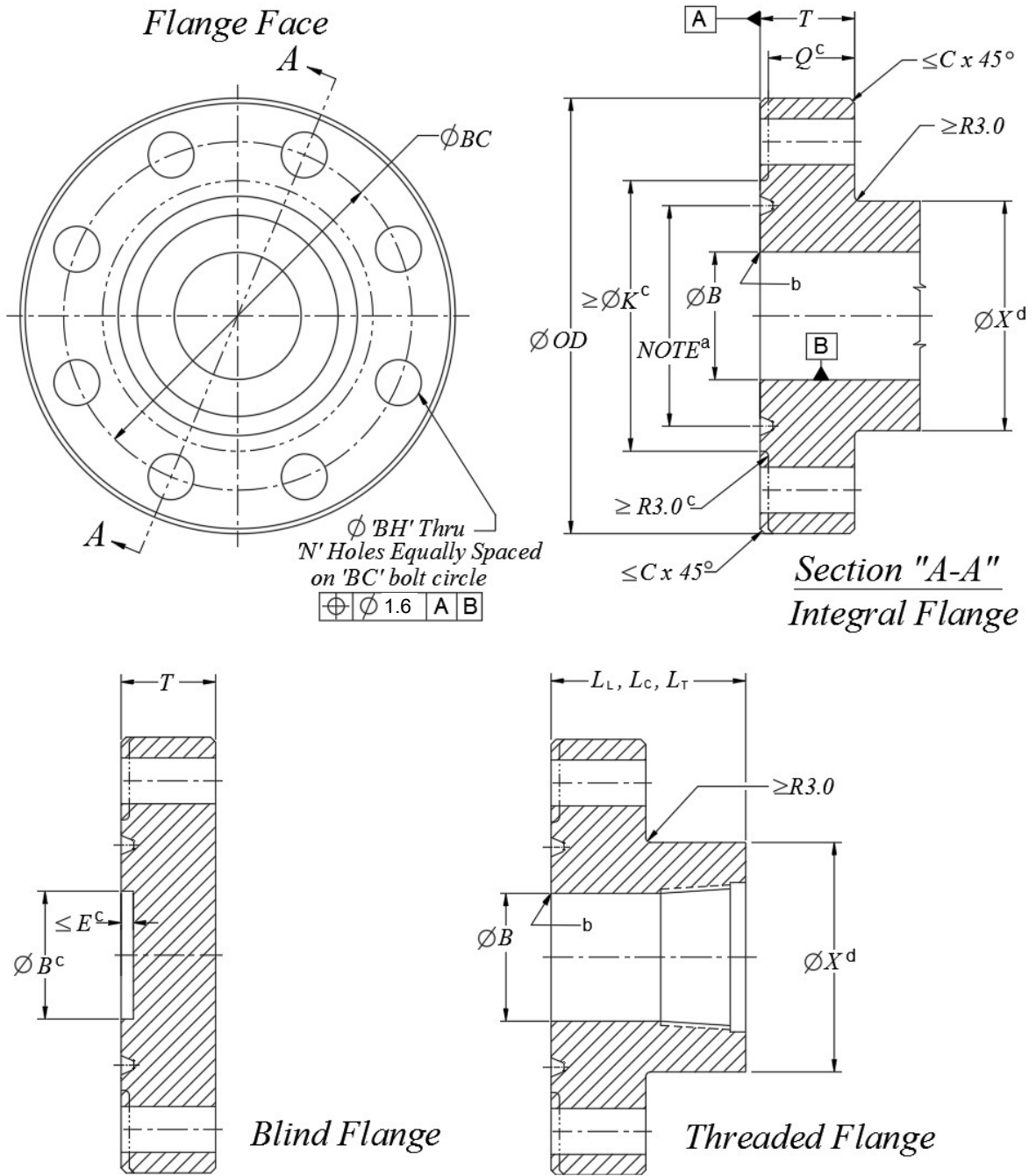

FOOTNOTES

- a Ring groove shall be concentric with bore B within 0.25 mm diametrical runout. See Table D.8 for ring groove dimensions.
- b Break sharp corner.
- c Raised face K and counterbore E are optional features.
- d Diameter X is a reference dimension.

Table D.2—Type 6B Flanges for 20.7 MPa (continued)

Dimensions in millimeters unless noted otherwise

Nominal Size of Flange ^a	Maximum Bore	Outside Diameter of Flange	Max. Chamfer	Diameter of Raised Face	Total Thickness of Flange	Basic Thickness of Flange	Diameter of Hub	Counter-bore Depth
in.	<i>B</i>	<i>OD</i>	<i>C</i>	<i>K</i>	<i>T</i>	<i>Q</i>	<i>X</i>	<i>E</i>
Tolerance>	max.	As noted	max.	min.	+3.0/-0	min.	Reference	+0.5/-0
2 ¹ / ₁₆	53.1	216 ±2	3	124	46.0	38.1	104.6	7.9
2 ⁹ / ₁₆	65.8	244 ±2	3	137	49.3	41.1	124.0	7.9
3 ¹ / ₈	81.8	241 ±2	3	155	46.0	38.1	127.0	7.9
4 ¹ / ₁₆	108.7	292 ±2	3	181	52.4	44.4	158.8	7.9
5 ¹ / ₈	131.1	349 ±2	3	216	58.7	50.8	190.5	7.9
7 ¹ / ₁₆	181.9	381 ±3	6	241	63.5	55.6	235.0	7.9
9	229.4	470 ±3	6	308	71.4	63.5	298.5	7.9
11	280.2	546 ±3	6	362	77.8	69.9	368.3	7.9
13 ⁵ / ₈	347.0	610 ±3	6	419	87.4	79.2	419.1	7.9
16 ³ / ₄	426.2	705 ±3	6	524	100.1	88.9	508.0	11.2
20 ³ / ₄	527.8	857 ±3	6	648	120.7	108.0	622.3	12.7

FOOTNOTE

^a For flange sizes 26³/₄ in. and 30 in., see Table D.7.

Nominal Size of Flange ^a	Diameter of Bolt Circle	Number of Bolts	Bolt Size and TPI	Bolt Holes		Hub Length, Threaded Flange			Ring Groove
						Line Pipe Flange	Casing Flange	Tubing Flange	
in.	<i>BC</i>	<i>N</i>	in.	<i>BH</i>		<i>L_L</i>	<i>L_C</i>	<i>L_T</i>	
Tolerance>	See figure for GDT		(Ref.)	Diameter	Tolerance	min.	min.	min.	
2 ¹ / ₁₆	165.1	8	7/8-9	26	+2/-0.5	65.0	—	65.0	R 24
2 ⁹ / ₁₆	190.5	8	1-8	29	+2/-0.5	71.4	—	71.4	R 27
3 ¹ / ₈	190.5	8	7/8-9	26	+2/-0.5	62.0	—	74.7	R 31
4 ¹ / ₁₆	235.0	8	1 ¹ / ₈ -8	32	+2/-0.5	77.7	88.9	88.9	R 37
5 ¹ / ₈	279.4	8	1 ¹ / ₄ -8	35	+2/-0.5	87.4	101.6	—	R 41
7 ¹ / ₁₆	317.5	12	1 ¹ / ₈ -8	32	+2/-0.5	93.7	114.3	—	R 45
9	393.7	12	1 ³ / ₈ -8	39	+2/-0.5	109.5	127.0	—	R 49
11	469.9	16	1 ³ / ₈ -8	39	+2/-0.5	115.8	133.4	—	R 53
13 ⁵ / ₈	533.4	20	1 ³ / ₈ -8	39	+2/-0.5	125.5	125.5	—	R 57
16 ³ / ₄	616.0	20	1 ⁵ / ₈ -8	45	+2.5/-0.5	128.5	144.5	—	R 66
20 ³ / ₄	749.3	20	2-8	54	+2.5/-0.5	171.5	171.5	—	R 74

FOOTNOTE

^a For flange sizes 26³/₄ in. and 30 in., see Table D.7.

Table D.3—Type 6B Flanges for 34.5 MPa

Dimensions in millimeters unless noted otherwise

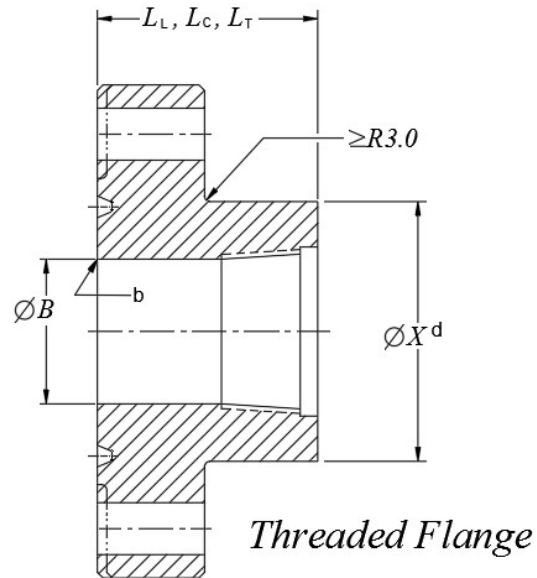
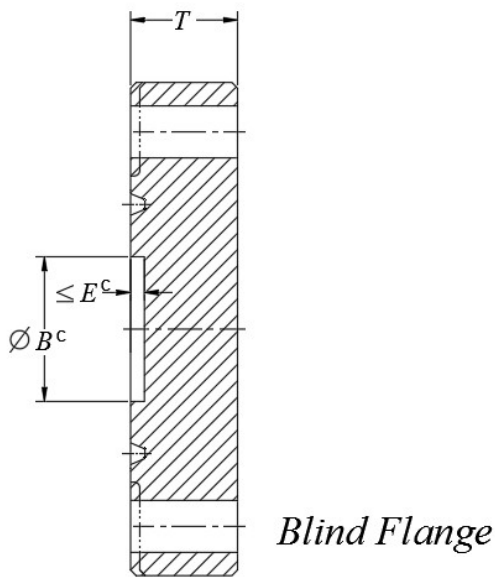
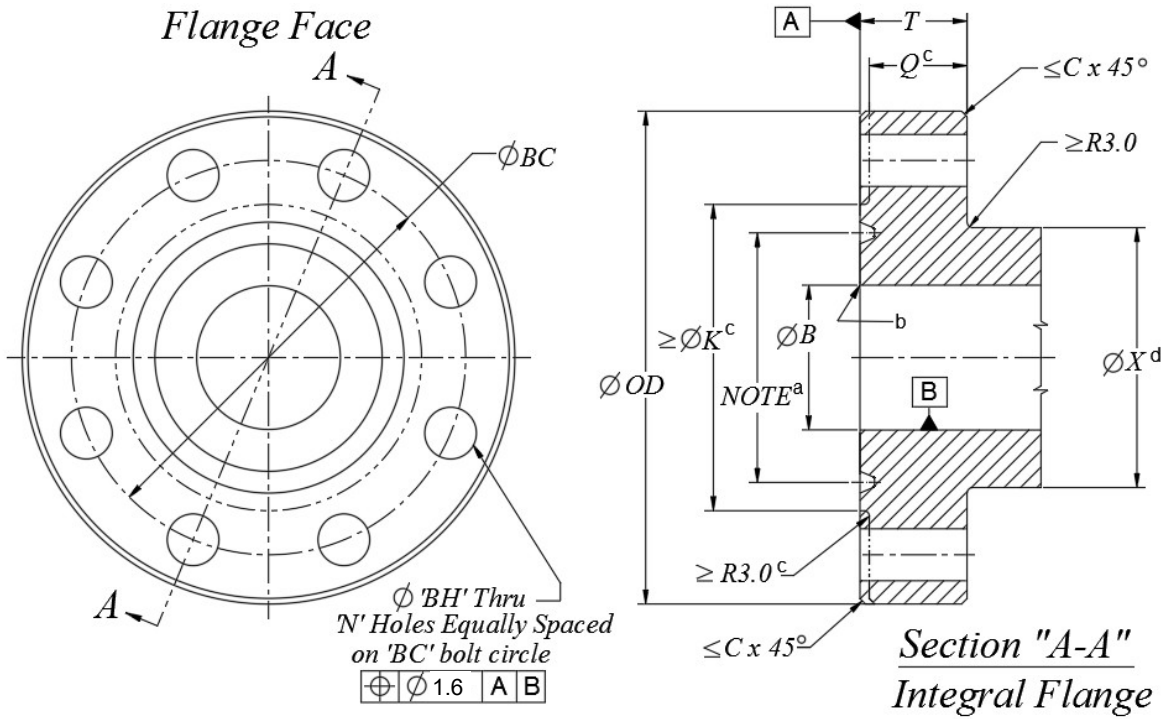

FOOTNOTES

- ^a Ring groove shall be concentric with bore *B* within 0.25 mm diametrical runout. See Table D.8 for ring groove dimensions.
- ^b Break sharp corner.
- ^c Raised face *K* and counterbore *E* are optional features.
- ^d Diameter *X* is a reference dimension.

Table D.3—Type 6B Flanges for 34.5 MPa (continued)

Dimensions in millimeters unless noted otherwise

Nominal Size of Flange ^a	Maximum Bore	Outside Diameter of Flange	Max. Chamfer	Diameter of Raised Face	Total Thickness of Flange	Basic Thickness of Flange	Diameter of Hub	Counter-bore Depth
in.	<i>B</i>	<i>OD</i>	<i>C</i>	<i>K</i>	<i>T</i>	<i>Q</i>	<i>X</i>	<i>E</i>
Tolerance>	max.	As noted	max.	min.	+3.0/-0	min.	Reference	+0.5/-0
2 ¹ / ₁₆	53.1	216 ±2	3	124	46.0	38.1	104.6	7.9
2 ⁹ / ₁₆	65.8	244 ±2	3	137	49.3	41.1	124.0	7.9
3 ¹ / ₈	81.8	267 ±2	3	168	55.7	47.8	133.3	7.9
4 ¹ / ₁₆	108.7	311 ±2	3	194	62.0	53.8	162.1	7.9
5 ¹ / ₈	131.1	375 ±2	3	229	81.0	73.2	196.8	7.9
7 ¹ / ₁₆	181.9	394 ±3	6	248	92.0	82.6	228.6	9.7
9	229.4	483 ±3	6	318	103.2	91.9	292.1	11.2
11	280.2	584 ±3	6	371	119.2	108.0	368.3	11.2

FOOTNOTE

^a For flange sizes 13⁵/₈ in., 16³/₄ in., 18³/₄ in., and 21¹/₄ in., see Table D.7.

Nominal Size of Flange ^a	Diameter of Bolt Circle	Number of Bolts	Bolt Size and TPI	Bolt Holes		Hub Length, Threaded Flange			Ring Groove
						Line Pipe Flange	Casing Flange	Tubing Flange	
in.	<i>BC</i>	<i>N</i>	in.	<i>BH</i>		<i>L_L</i>	<i>L_C</i>	<i>L_T</i>	
Tolerance>	See figure for GDT	(Ref.)	Diameter	Tolerance	min.	min.	min.		
2 ¹ / ₁₆	165.1	8	7/8-9	26	+2/-0.5	65.0	—	65.0	R 24
2 ⁹ / ₁₆	190.5	8	1-8	29	+2/-0.5	71.4	—	71.4	R 27
3 ¹ / ₈	203.2	8	1 ¹ / ₈ -8	32	+2/-0.5	81.0	—	81.0	R 35
4 ¹ / ₁₆	241.3	8	1 ¹ / ₄ -8	35	+2/-0.5	98.6	98.6	98.6	R 39
5 ¹ / ₈	292.1	8	1 ¹ / ₂ -8	42	+2.5/-0.5	112.8	112.8	—	R 44
7 ¹ / ₁₆	317.5	12	1 ³ / ₈ -8	39	+2/-0.5	128.5	128.5	—	R 46
9	393.7	12	1 ⁵ / ₈ -8	45	+2.5/-0.5	153.9	153.9	—	R 50
11	482.6	12	1 ⁷ / ₈ -8	51	+2.5/-0.5	169.9	169.9	—	R 54

FOOTNOTE

^a For flange sizes 13⁵/₈ in., 16³/₄ in., 18³/₄ in., and 21¹/₄ in., see Table D.7.

Table D.4—Type 6BX Flanges for 69.0 MPa

Dimensions in millimeters unless noted otherwise

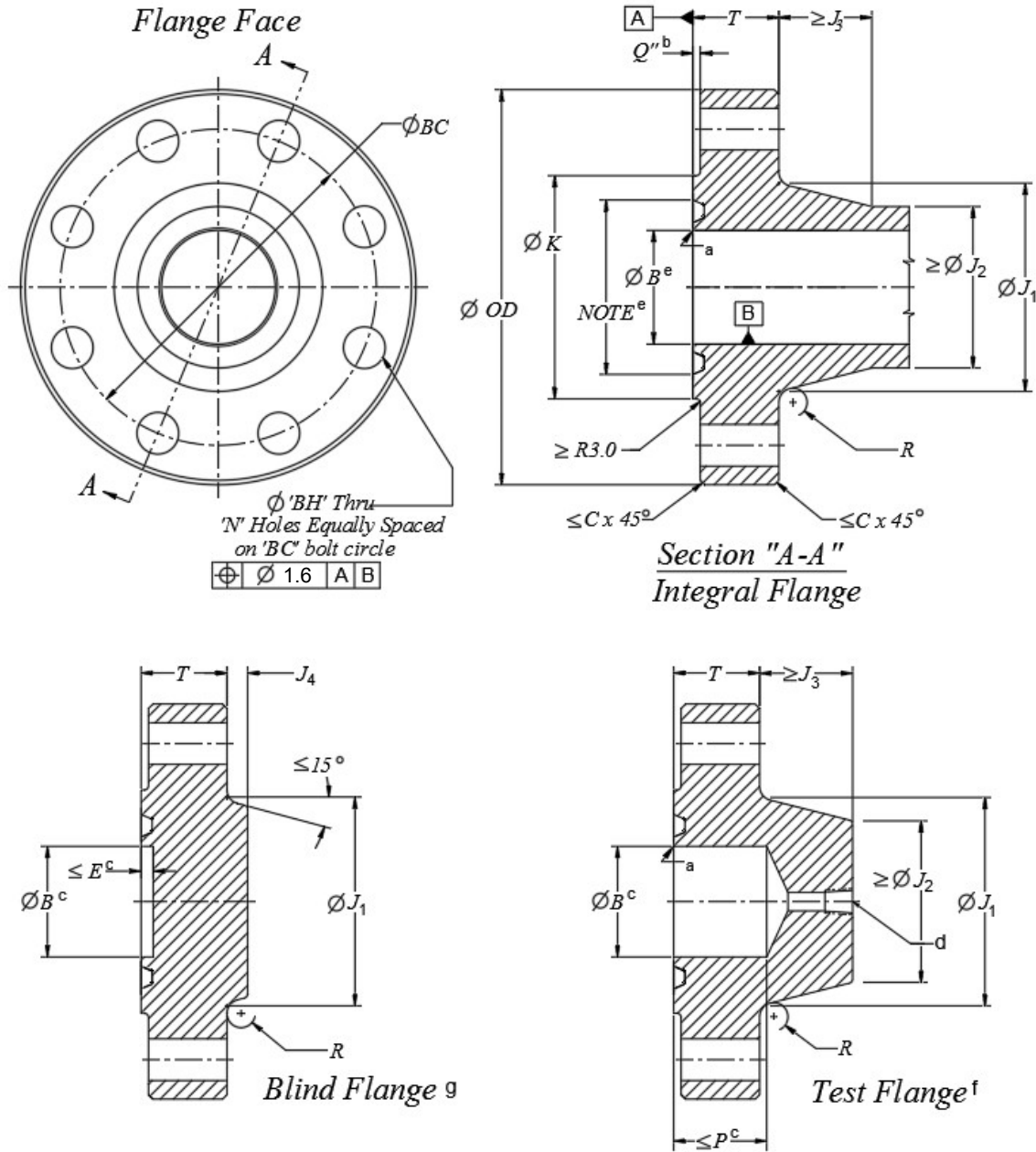

FOOTNOTES

- ^a Break sharp corner.
- ^b Q'' max. = E ; Q'' min. = 3 mm. See Table D.11 for value of E if not listed. Raised face ($\varnothing K$) may be omitted on studed connectors, but thickness T shall still apply.
- ^c Optional feature.
- ^d Test connection shall be $1/2$ in. NPT or per 9.3 (Figure 5).
- ^e Ring groove shall be concentric with bore B within 0.25 mm diametrical runout. See Table D.11 for ring groove dimensions.
- ^f Test flange style—applies to sizes $1^{13}/_{16}$ through $5^{1}/_8$ only.
- ^g Blind flange style—applies to sizes $5^{1}/_8$ through $21^{1}/_4$ only.
- ^h If the minimum value of J_3 is exceeded, the maximum depth P of the counterbore may be increased by the same amount or less.

Table D.4—Type 6BX Flanges for 69.0 MPa (continued)

Dimensions in millimeters unless noted otherwise

Nominal Size	Maximum Bore	Outside Diameter of Flange	Diameter of Raised Face	Total Thickness	Max. Chamfer	Large Hub Diameter	Small Hub Diameter	Length of Hub	Hub Height
in.	<i>B</i>	<i>OD</i>	<i>K</i>	<i>T</i>	<i>C</i>	<i>J₁</i>	<i>J₂</i>	<i>J₃</i>	<i>J₄</i>
Tolerance>	max.	As noted	± 1.5	+3.0/-0	max.	+0/-3.0	min.	min.	min.
1 ¹³ / ₁₆	46.7	187 ±2	105	42.2	3	88.9	65.0	48.5	—
2 ¹ / ₁₆	53.1	200 ±2	111	44.0	3	100.1	74.7	51.6	—
2 ⁹ / ₁₆	65.8	232 ±2	132	51.3	3	120.7	91.9	57.2	—
3 ¹ / ₁₆	78.5	270 ±2	152	58.5	3	142.0	110.2	63.5	—
4 ¹ / ₁₆	103.9	316 ±2	185	70.4	3	182.6	146.1	73.2	—
5 ¹ / ₈	131.1	357 ±2	221	79.3	3	223.8	182.6	81.0	6.4
7 ¹ / ₁₆	180.1	480 ±2.5	302	103.2	6	301.8	254.0	95.3	9.7
9	229.4	552 ±2.5	359	124.0	6	374.7	327.2	93.7	9.7
11	280.2	654 ±2.5	429	141.3	6	450.9	400.1	103.1	14.2
13 ⁵ / ₈	347.0	768 ±2.5	518	168.2	6	552.5	495.3	114.3	17.5
16 ³ / ₄	426.2	871 ±2.5	576	168.2	6	655.6	601.7	76.2	30.2
18 ³ / ₄	477.0	1040 ±2.5	697	223.0	6	752.3	674.6	155.4	25.4
21 ¹ / ₄	540.5	1143 ±2.5	781	241.3	6	847.9	762.0	165.1	31.8

Nominal Size	Radius of Hub	Bolt Circle	Number of Bolts	Bolt Size and TPI	Bolt Holes		Counterbore Depth		Ring Groove
					<i>BH</i>		<i>E</i>	<i>P^h</i>	
in.	<i>R</i>	<i>BC</i>	<i>N</i>	in.					
Tolerance>	± 1	See figure for GDT		(Ref.)	Diameter	Tolerance	max.	max. ^h	
1 ¹³ / ₁₆	10	146.1	8	3/4-10	23	+2/-0.5	6.1	48.0	BX 151
2 ¹ / ₁₆	10	158.8	8	3/4-10	23	+2/-0.5	6.4	51.3	BX 152
2 ⁹ / ₁₆	10	184.2	8	7/8-9	26	+2/-0.5	7.2	61.5	BX 153
3 ¹ / ₁₆	10	215.9	8	1-8	29	+2/-0.5	8.1	71.9	BX 154
4 ¹ / ₁₆	10	258.8	8	1 1/8-8	32	+2/-0.5	8.9	87.6	BX 155
5 ¹ / ₈	10	300.0	12	1 1/8-8	32	+2/-0.5	9.5	98.0	BX 169
7 ¹ / ₁₆	16	403.4	12	1 1/2-8	42	+2.5/-0.5	11.1	—	BX 156
9	16	476.3	16	1 1/2-8	42	+2.5/-0.5	12.7	—	BX 157
11	16	565.2	16	1 3/4-8	48	+2.5/-0.5	14.3	—	BX 158
13 ⁵ / ₈	16	673.1	20	1 7/8-8	51	+2.5/-0.5	15.9	—	BX 159
16 ³ / ₄	19	776.2	24	1 7/8-8	51	+2.5/-0.5	8.3	—	BX 162
18 ³ / ₄	16	925.6	24	2 1/4-8	61	+2.5/-0.5	18.3	—	BX 164
21 ¹ / ₄	21	1022.4	24	2 1/2-8	67	+2.5/-0.5	19.1	—	BX 166

Table D.5—Type 6BX Flanges for 103.5 MPa

Dimensions in millimeters unless noted otherwise

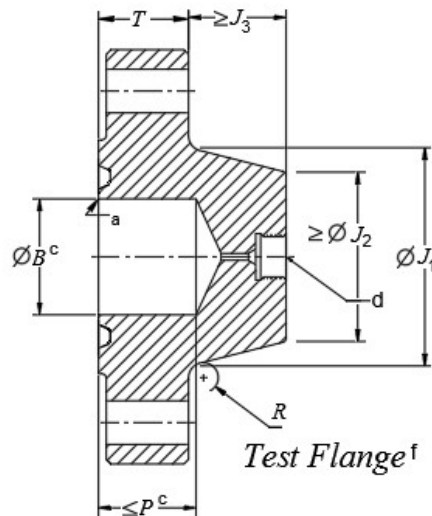
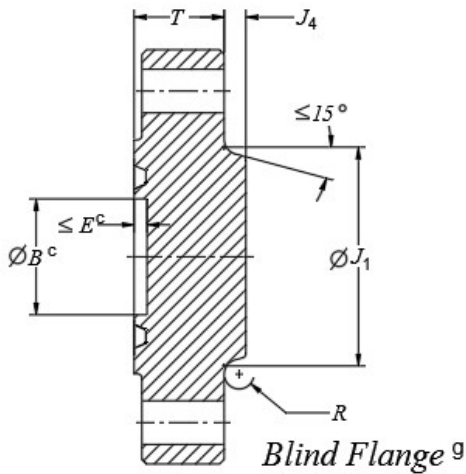
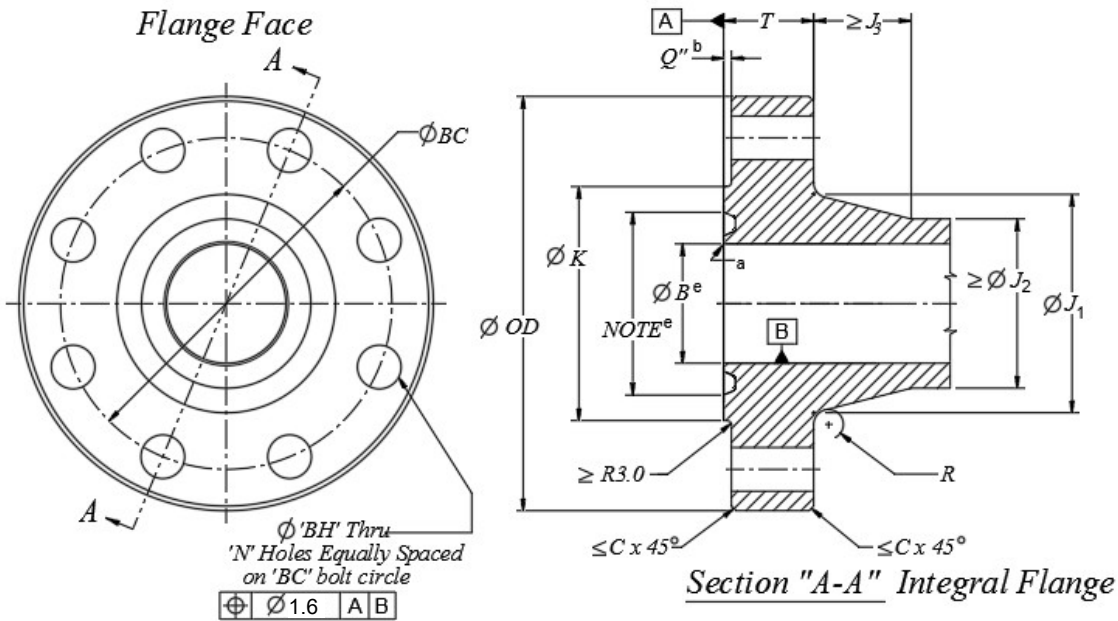

FOOTNOTES

- a Break sharp corner.
- b Q'' max. = E ; Q'' min. = 3 mm. See Table D.11 for value of E if not listed. Raised face (ϕK) may be omitted on studed connectors, but thickness T shall still apply.
- c Optional feature.
- d Test connection shall be per 9.3 (Figure 5).
- e Ring groove shall be concentric with bore B within 0.25 mm diametrical runout. See Table D.11 for ring groove dimensions.
- f Test flange style—applies to sizes $1^{13}/_{16}$ through $5^{1}/_{8}$ only.
- g Blind flange style—applies to sizes $5^{1}/_{8}$ through $18^{3}/_{4}$ only.
- h If the minimum value of J_3 is exceeded, the maximum depth P of the counterbore may be increased by the same amount or less.

Table D.5—Type 6BX Flanges for 103.5 MPa (continued)

Dimensions in millimeters unless noted otherwise

Nominal Size of Flange	Maximum Bore	Outside Diameter of Flange	Diameter of Raised Face	Total Thickness of Flange	Max. Chamfer	Large Hub Diameter	Small Hub Diameter	Hub Length	Test Flange C'bore Depth
in.	<i>B</i>	<i>OD</i>	<i>K</i>	<i>T</i>	<i>C</i>	<i>J₁</i>	<i>J₂</i>	<i>J₃</i>	<i>p^h</i>
Tolerance>	max.	As noted	± 1.5	+3.0/-0	max.	+0/-3.0	min.	min.	max. ^h
1 ¹³ / ₁₆	46.7	208 ±2	106	45.3	3	97.5	71.4	47.8	50.3
2 ¹ / ₁₆	53.1	222 ±2	114	50.8	3	111.3	82.5	53.8	60.5
2 ⁹ / ₁₆	65.8	254 ±2	133	57.2	3	128.5	100.1	57.2	67.3
3 ¹ / ₁₆	78.5	287 ±2	154	64.3	3	153.9	122.2	63.5	77.7
4 ¹ / ₁₆	103.9	360 ±2	194	78.5	3	195.3	158.7	73.2	95.8
5 ¹ / ₈	131.1	419 ±2	226	98.6	3	244.3	200.2	81.8	118.1
7 ¹ / ₁₆	180.1	505 ±3	305	119.1	6	325.4	276.4	91.9	—
9	229.4	648 ±3	381	146.1	6	431.8	349.3	124.0	—
11	280.2	813 ±3	454	187.5	6	584.2	427.0	235.7	—
13 ⁵ / ₈	347.0	886 ±3	541	204.7	6	595.4	528.6	114.3	—
18 ³ / ₄	477.0	1162 ±3	722	255.5	6	812.8	730.2	155.4	—

Nominal Size of Flange	Radius of Hub	Bolt Circle	Number of Bolts	Bolt Size and TPI	Bolt Holes		Blind Flange		Ring Groove
					<i>BH</i>		Counter-bore Depth	Hub Height	
in.	<i>R</i>	<i>BC</i>	<i>N</i>	in.	<i>BH</i>		<i>E</i>	<i>J₄</i>	
Tolerance>	± 1	See figure for GDT		(Ref.)	Diameter	Tolerance	max.	min.	
1 ¹³ / ₁₆	10	160.3	8	7/8-9	26	+2/-0.5	6.0	—	BX 151
2 ¹ / ₁₆	10	174.8	8	7/8-9	26	+2/-0.5	6.4	—	BX 152
2 ⁹ / ₁₆	10	200.2	8	1-8	29	+2/-0.5	7.2	—	BX 153
3 ¹ / ₁₆	10	230.1	8	1 ¹ / ₈ -8	32	+2/-0.5	8.0	—	BX 154
4 ¹ / ₁₆	10	290.6	8	1 ³ / ₈ -8	39	+2/-0.5	8.8	—	BX 155
5 ¹ / ₈	16	342.9	12	1 ¹ / ₂ -8	42	+2.5/-0.5	9.5	6.4	BX 169
7 ¹ / ₁₆	16	428.7	16	1 ¹ / ₂ -8	42	+2.5/-0.5	11.1	7.9	BX 156
9	16	552.4	16	1 ⁷ / ₈ -8	51	+2.5/-0.5	12.7	14.2	BX 157
11	16	711.2	20	2-8	54	+2.5/-0.5	14.3	12.7	BX 158
13 ⁵ / ₈	25	771.7	20	2 ¹ / ₄ -8	61	+2.5/-0.5	15.9	17.5	BX 159
18 ³ / ₄	25	1016.0	20	3-8	80	+3/-0.5	18.3	35.1	BX 164

Table D.6—Type 6BX Flanges for 138.0 MPa

Dimensions in millimeters unless noted otherwise

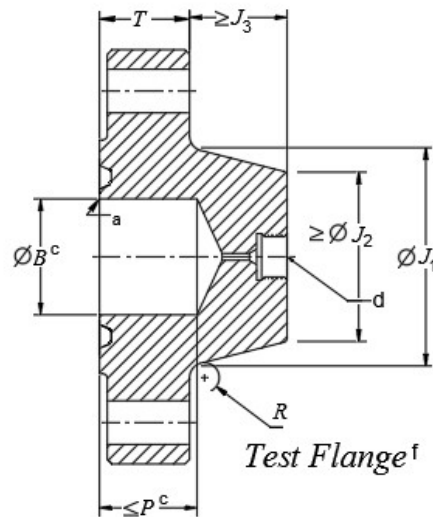
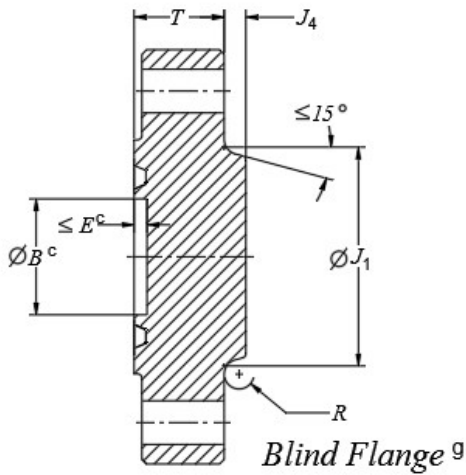
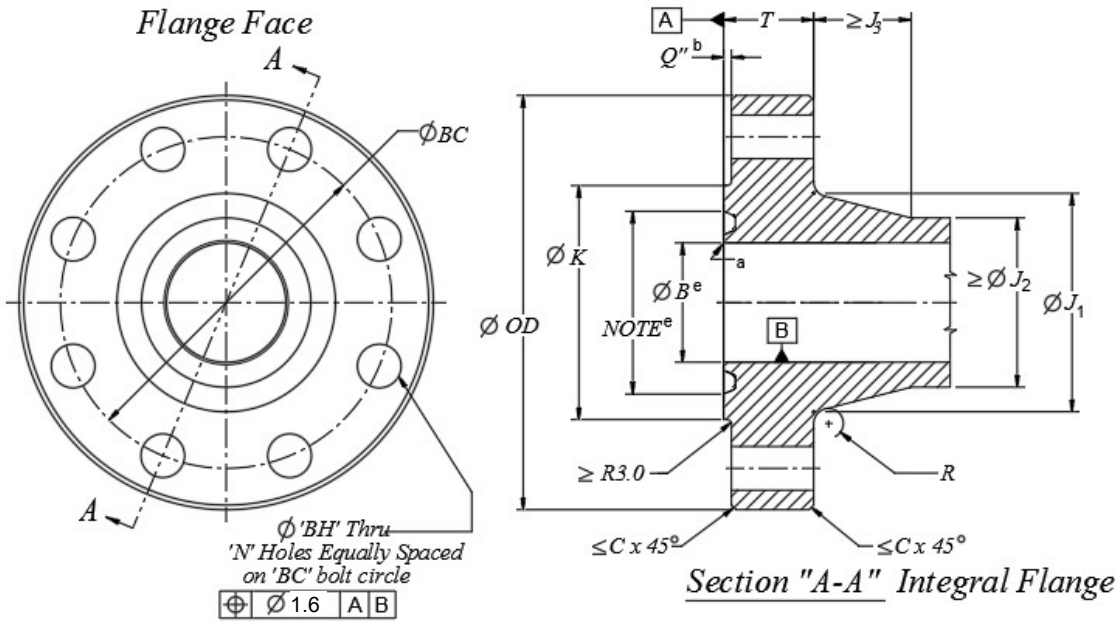

FOOTNOTES

- a Break sharp corner.
- b Q'' max. = E ; Q'' min. = 3 mm. See Table D.11 for value of E if not listed. Raised face (ϕK) may be omitted on studed connectors, but thickness T shall still apply.
- c Optional feature.
- d Test connection shall be per 9.3 (Figure 5).
- e Ring groove shall be concentric with bore B within 0.25 mm. diametrical runout. See Table D.11 for ring groove dimensions.
- f Test flange style—applies to sizes $1^{13}/_{16}$ through $4^{1}/_{16}$ only.
- g Blind flange style—applies to sizes $7^{1}/_{16}$ through $18^{3}/_{4}$ only.
- h If the minimum value of J_3 is exceeded, the maximum depth P of the counterbore may be increased by the same amount or less.

Table D.6—Type 6BX Flanges for 138.0 MPa (continued)

Dimensions in millimeters unless noted otherwise

Nominal Size of Flange	Maximum Bore	Outside Diameter of Flange	Diameter of Raised Face	Total Thickness of Flange	Max. Chamfer	Large Hub Diameter	Small Hub Diameter	Hub Length	Test Flange C'bore Depth
in.	<i>B</i>	<i>OD</i>	<i>K</i>	<i>T</i>	<i>C</i>	<i>J₁</i>	<i>J₂</i>	<i>J₃</i>	<i>P^h</i>
Tolerance>	max.	As noted	± 1.5	+3.0/−0	max.	+0/−3.0	min.	min.	max. ^h
1 ¹³ / ₁₆	46.7	257 ±2	117	63.5	3	133.4	109.5	49.3	63.5
2 ¹ / ₁₆	53.1	287 ±2	132	71.4	3	153.9	127.0	52.3	63.5
2 ⁹ / ₁₆	65.8	325 ±2	151	79.3	3	173.0	144.5	58.7	63.5
3 ¹ / ₁₆	78.5	357 ±2	171	85.9	3	192.0	160.3	63.5	63.5
4 ¹ / ₁₆	103.9	446 ±2	219	106.5	3	242.8	206.2	73.2	63.5
7 ¹ / ₁₆	180.1	656 ±3	353	165.1	6	385.8	338.1	96.8	—
9	229.4	805 ±3	441	204.8	6	481.1	428.8	107.9	—
11	280.2	883 ±3	505	223.8	6	566.7	508.0	103.1	—
13 ⁵ / ₈	347.0	1162 ±3	614	292.1	6	693.7	628.6	133.3	—

Nominal Size of Flange	Radius of Hub	Bolt Circle	Number of Bolts	Bolt Size and TPI	Bolt Holes		Blind Flange		Ring Groove
					<i>BH</i>		C'bore Depth	Hub Height	
in.	<i>R</i>	<i>BC</i>	<i>N</i>	in.	<i>BH</i>		<i>E</i>	<i>J₄</i>	
Tolerance>	± 1	See figure for GDT		(Ref.)	Diameter	Tolerance	max.	min.	
1 ¹³ / ₁₆	10	203.2	8	1-8	29	+2/−0.5	6.0	—	BX 151
2 ¹ / ₁₆	10	230.1	8	1 ¹ / ₈ -8	32	+2/−0.5	6.4	—	BX 152
2 ⁹ / ₁₆	10	261.9	8	1 ¹ / ₄ -8	35	+2/−0.5	7.2	—	BX 153
3 ¹ / ₁₆	10	287.3	8	1 ³ / ₈ -8	39	+2/−0.5	8.0	—	BX 154
4 ¹ / ₁₆	10	357.1	8	1 ³ / ₄ -8	48	+2.5/−0.5	8.8	—	BX 155
7 ¹ / ₁₆	16	554.0	16	2-8	54	+2.5/−0.5	11.1	7.9	BX 156
9	25	685.8	16	2 ¹ / ₂ -8	67	+2.5/−0.5	12.7	6.4	BX 157
11	25	749.3	16	2 ³ / ₄ -8	74	+2.5/−0.5	14.3	12.7	BX 158
13 ⁵ / ₈	25	1016.0	20	3-8	80	+3/−0.5	15.9	14.2	BX 159

Table D.7—Type 6BX Large-bore Flanges for 13.8 MPa, 20.7 MPa, and 34.5 MPa

Dimensions in millimeters unless noted otherwise

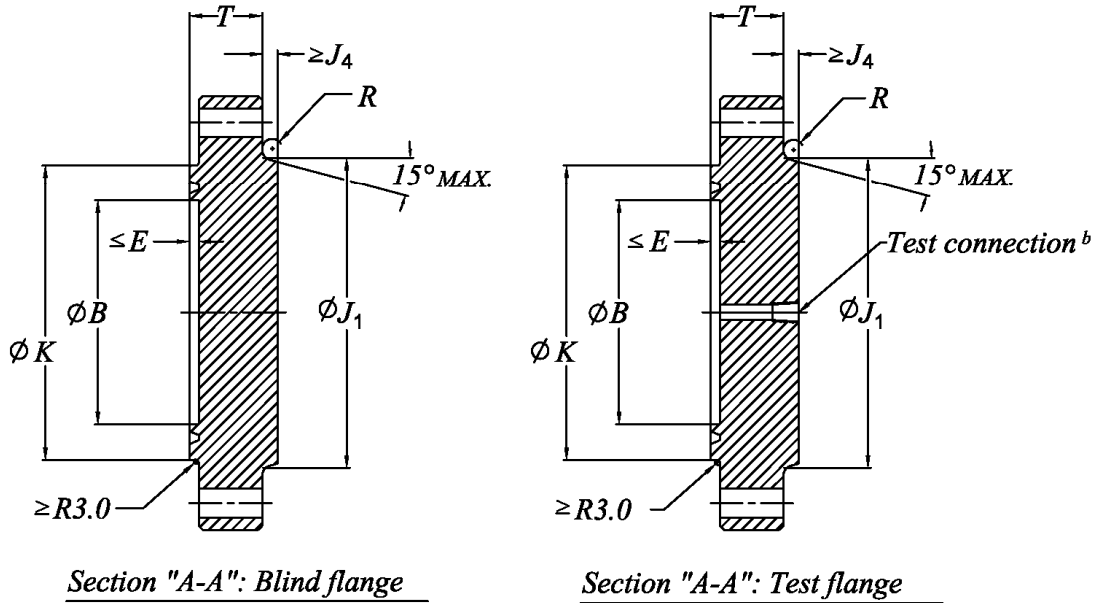
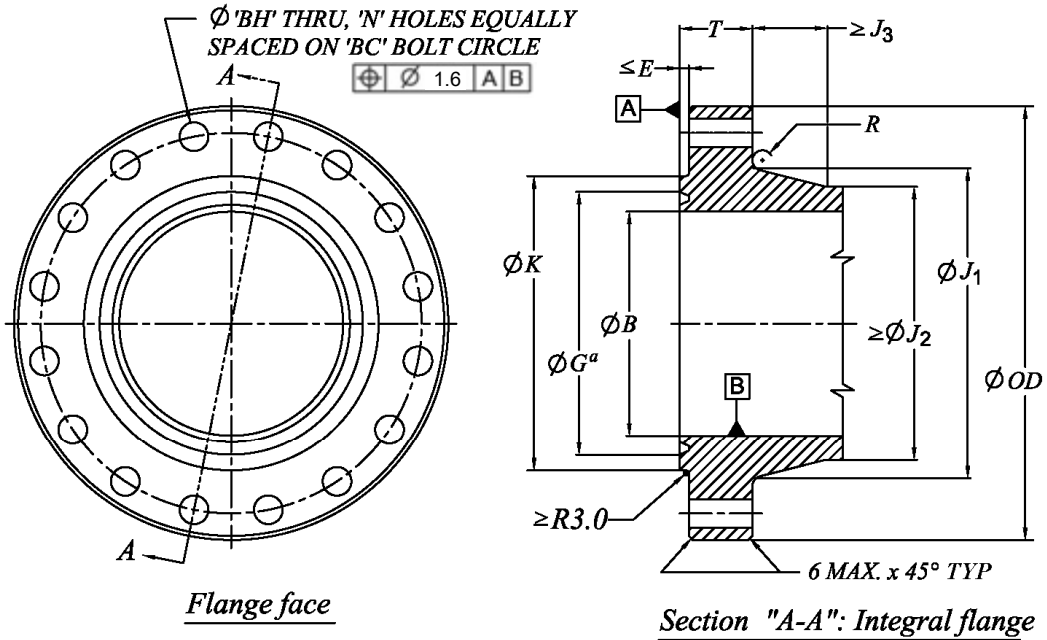

FOOTNOTES

- ^a Ring groove shall be concentric with bore *B* within 0.25 mm diametrical runout. See Table D.11 for ring groove dimensions.
- ^b Test connection shall be 1/2 in. NPT or per 9.3 (Figure 5).
- ^c *Q'* min. = 3 mm (may be omitted for studed flanges).
- ^d Counterbore *E* for blind and test flanges is optional.
- ^e Break sharp corner.

Table D.7—Type 6BX Large-bore Flanges for 13.8 MPa, 20.7 MPa, and 34.5 MPa (continued)

Dimensions in millimeters unless noted otherwise

Nominal Size	Maximum Bore	OD of Flange	Raised Face Depth	Raised Face Diameter	Total Thickness	Large Hub Diameter	Small Hub Diameter	Length of Hub
in.	<i>B</i>	<i>OD</i>	<i>Q</i> "	<i>K</i>	<i>T</i>	<i>J</i> ₁	<i>J</i> ₂	<i>J</i> ₃
Tolerance>	max.	As noted	max.	± 1.5	+3.0/−0	+0/−3.0	min.	min.
13.8 MPa								
26 ³ / ₄	680.2	1041 ±3	6.4	805	126.3	835.9	743.0	185.7
30	762.8	1122 ±3	6.4	908	134.2	931.9	833.1	196.9
20.7 MPa								
26 ³ / ₄	680.2	1102 ±3	6.4	832	161.1	870.0	776.2	185.7
30	762.8	1186 ±3	6.4	922	167.2	970.0	871.2	196.9
34.5 MPa								
13 ⁵ / ₈	347.0	673 ±3	6.4	457	112.8	481.1	423.9	114.3
16 ³ / ₄	426.2	772 ±3	6.4	535	130.1	555.8	527.1	76.2
18 ³ / ₄	477.0	905 ±3	6.4	627	165.9	674.6	598.4	152.4
21 ¹ / ₄	540.5	991 ±3	6.4	702	180.9	759.0	679.5	165.1

Nominal Size	Radius of Hub	Bolt Circle	Number of Bolts	Bolt Size and TPI	Bolt Hole Diameter	Blind Flange		Ring Groove
						Counter-bore Depth	Hub Height	
in.	<i>R</i>	<i>BC</i>	<i>N</i>	in.	<i>BH</i>	<i>E</i>	<i>J</i> ₄	
Tolerance>	± 1	See figure for GDT		(Ref.)	+2.5/−0.5	max.	min.	
13.8 MPa								
26 ³ / ₄	16	952.5	20	1 ³ / ₄ -8	48	21.4	9.7	BX 167
30	16	1039.9	32	1 ⁵ / ₈ -8	45	23.0	17.5	BX 303
20.7 MPa								
26 ³ / ₄	16	1000.3	24	2-8	54	21.4	NA	BX 168
30	16	1090.7	32	1 ⁷ / ₈ -8	51	23.0	12.7	BX 303
34.5 MPa								
13 ⁵ / ₈	16	590.6	16	1 ⁵ / ₈ -8	45	14.3	23.9	BX 160
16 ³ / ₄	19	676.1	16	1 ⁷ / ₈ -8	51	8.3	17.5	BX 162
18 ³ / ₄	16	803.1	20	2-8	54	18.3	19.1	BX 163
21 ¹ / ₄	18	886.0	24	2-8	54	19.1	22.4	BX 165

Table D.8—Type R Ring Grooves

Dimensions in millimeters unless noted otherwise; surface roughness in micrometers

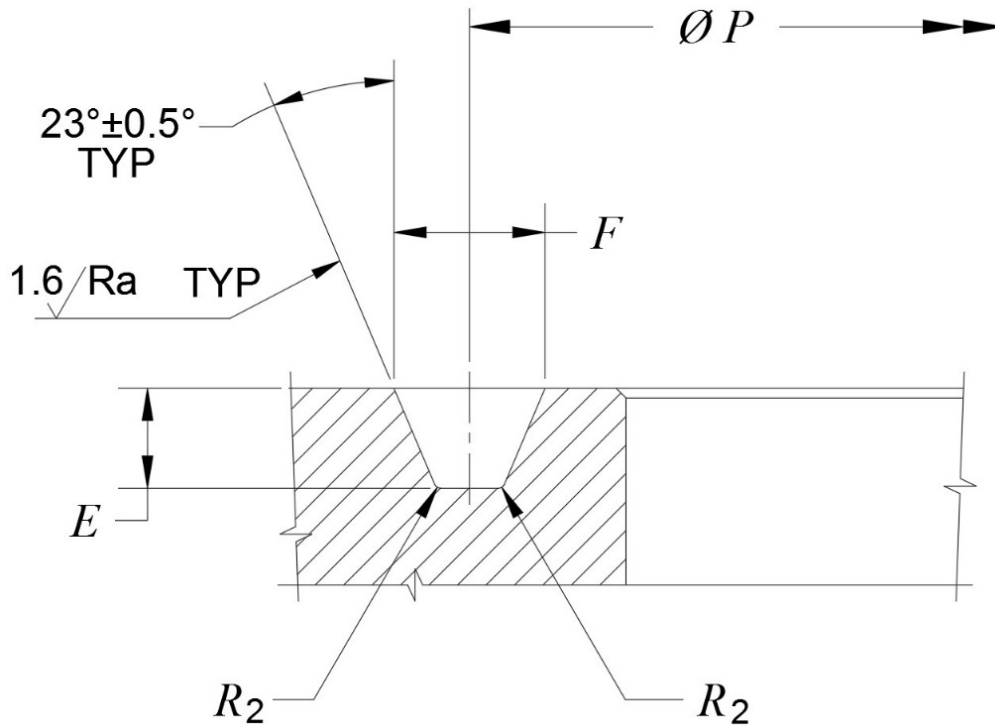

Table D.8—Type R Ring Grooves *(continued)*

Dimensions in millimeters unless noted otherwise

Groove Number	Nominal Size of Flange in.	Pitch Diameter <i>P</i>	Depth of Groove <i>E</i>	Width of Groove <i>F</i>	Radius in Groove <i>R</i> ₂
Tolerance>	(Ref.)	± 0.13	+0.5/-0	± 0.20	max.
R 23	2 ¹ / ₁₆	82.55	7.9	11.91	0.8
R 24	2 ¹ / ₁₆	95.25	7.9	11.91	0.8
R 26	2 ⁹ / ₁₆	101.60	7.9	11.91	0.8
R 27	2 ⁹ / ₁₆	107.95	7.9	11.91	0.8
R 31	3 ¹ / ₈	123.83	7.9	11.91	0.8
R 35	3 ¹ / ₈	136.53	7.9	11.91	0.8
R 37	4 ¹ / ₁₆	149.23	7.9	11.91	0.8
R 39	4 ¹ / ₁₆	161.93	7.9	11.91	0.8
R 41	5 ¹ / ₈	180.98	7.9	11.91	0.8
R 44	5 ¹ / ₈	193.68	7.9	11.91	0.8
R 45	7 ¹ / ₁₆	211.15	7.9	11.91	0.8
R 46	7 ¹ / ₁₆	211.15	9.7	13.49	1.5
R 49	9	269.88	7.9	11.91	0.8
R 50	9	269.88	11.2	16.66	1.5
R 53	11	323.85	7.9	11.91	0.8
R 54	11	323.85	11.2	16.66	1.5
R 57	13 ⁵ / ₈	381.00	7.9	11.91	0.8
R 65	16 ³ / ₄	469.90	7.9	11.91	0.8
R 66	16 ³ / ₄	469.90	11.2	16.66	1.5
R 73	21 ¹ / ₄	584.20	9.7	13.49	1.5
R 74	20 ³ / ₄	584.20	12.7	19.84	1.5

Table D.9—Type R Ring Gaskets

Dimensions in millimeters unless noted otherwise; surface roughness in micrometers

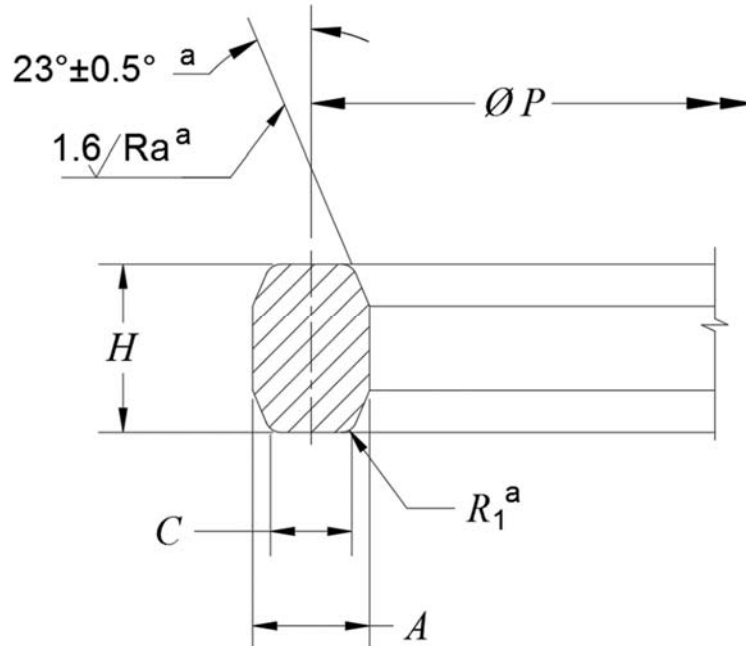
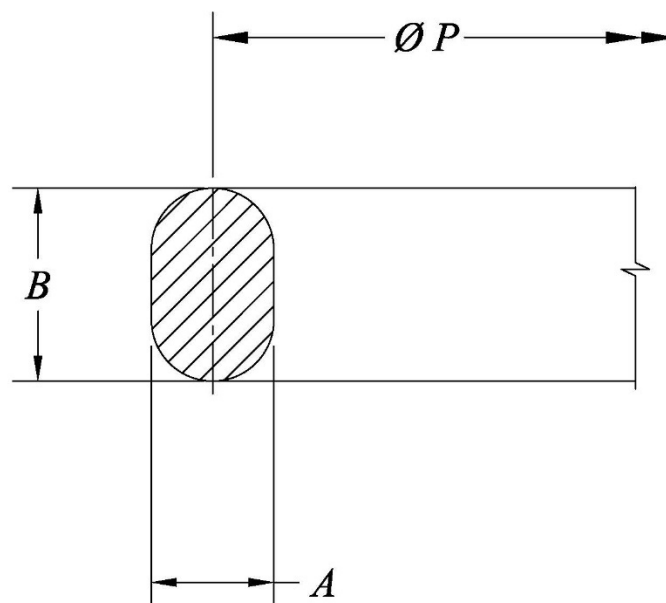
a) Octagonal gasket style**b) Oval gasket style**

FOOTNOTE

^a Typical four places.

Table D.9—Type R Ring Gaskets *(continued)*

Dimensions in millimeters unless noted otherwise

Gasket Number	Pitch Diameter	Width of Ring	Height of Oval Ring	Height of Octagonal Ring	Width of Flat on Octagonal Ring	Radius on Octagonal Ring	Distance between Flanges
	<i>P</i>	<i>A</i>	<i>B</i>	<i>H</i>	<i>C</i>	<i>R</i> ₁	<i>S</i>
Tolerance>	± 0.18	± 0.20	± 0.5	± 0.5	± 0.20	± 0.5	(Approx.)
R 23	82.55	11.13	17.5	15.9	7.75	1.5	4.8
R 24	95.25	11.13	17.5	15.9	7.75	1.5	4.8
R 26	101.6	11.13	17.5	15.9	7.75	1.5	4.8
R 27	107.95	11.13	17.5	15.9	7.75	1.5	4.8
R 31	123.83	11.13	17.5	15.9	7.75	1.5	4.8
R 35	136.53	11.13	17.5	15.9	7.75	1.5	4.8
R 37	149.23	11.13	17.5	15.9	7.75	1.5	4.8
R 39	161.93	11.13	17.5	15.9	7.75	1.5	4.8
R 41	180.98	11.13	17.5	15.9	7.75	1.5	4.8
R 44	193.68	11.13	17.5	15.9	7.75	1.5	4.8
R 45	211.15	11.13	17.5	15.9	7.75	1.5	4.8
R 46	211.15	12.70	19.1	17.5	8.66	1.5	4.8
R 49	269.88	11.13	17.5	15.9	7.75	1.5	4.8
R 50	269.88	15.88	22.4	20.6	10.49	1.5	4.1
R 53	323.85	11.13	17.5	15.9	7.75	1.5	4.8
R 54	323.85	15.88	22.4	20.6	10.49	1.5	4.1
R 57	381.00	11.13	17.5	15.9	7.75	1.5	4.8
R 65	469.90	11.13	17.5	15.9	7.75	1.5	4.8
R 66	469.90	15.88	22.4	20.6	10.49	1.5	4.1
R 73	584.20	12.70	19.1	17.5	8.66	1.5	3.3
R 74	584.20	19.05	25.4	23.9	12.32	1.5	4.8

Table D.10—Type RX Ring Gaskets

Dimensions in millimeters unless noted otherwise; surface roughness in micrometers

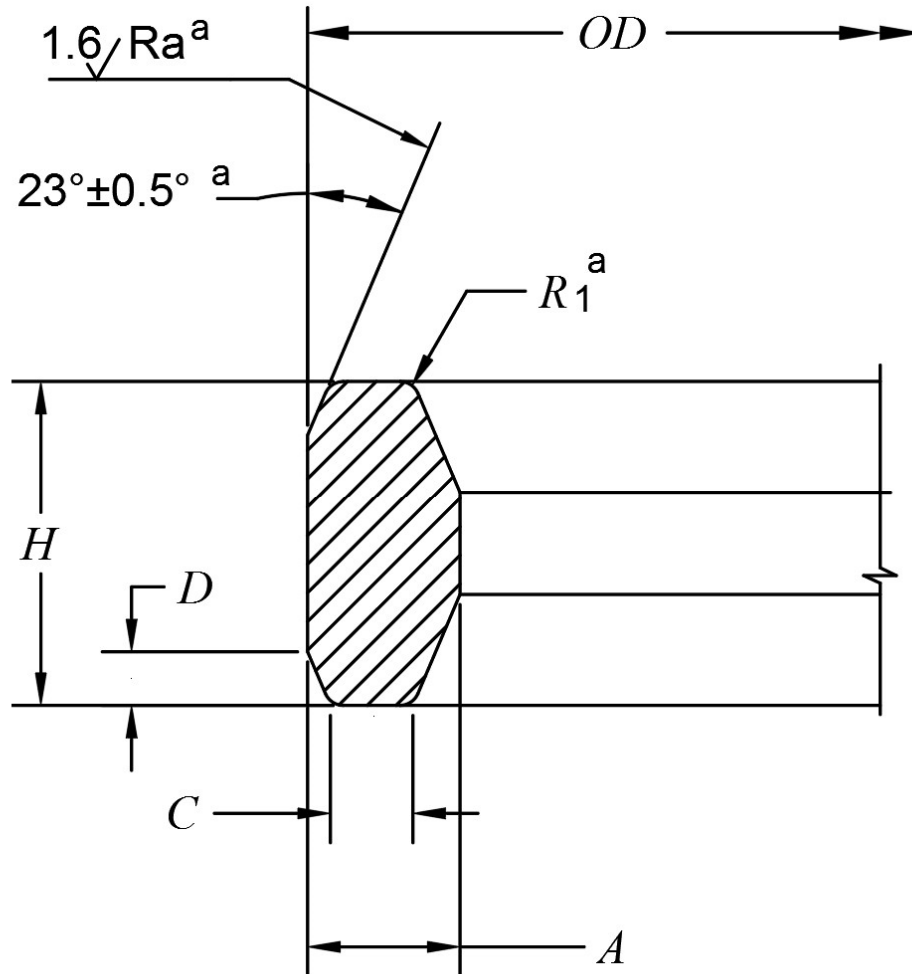

FOOTNOTE

^a Typical four places.

Table D.10—Type RX Ring Gaskets (continued)

Dimensions in millimeters unless noted otherwise

Gasket Number	Outside Diameter <i>OD</i>	Width of Ring <i>A</i> ^a	Width of Flat <i>C</i>	Height of Ring <i>H</i> ^a	Height of OD Bevel <i>D</i>	Radius on Ring <i>R</i> ₁	Distance between Flanges <i>S</i>
Tolerance>	+0.50/-0	+0.20/-0	+0.15/-0	+0.20/-0	+0/-0.80	± 0.5	(Approx.)
RX 23	93.27	11.91	6.45	25.40	4.24	1.5	11.9
RX 24	105.97	11.91	6.45	25.40	4.24	1.5	11.9
RX 26	111.91	11.91	6.45	25.40	4.24	1.5	11.9
RX 27	118.26	11.91	6.45	25.40	4.24	1.5	11.9
RX 31	134.54	11.91	6.45	25.40	4.24	1.5	11.9
RX 35	147.24	11.91	6.45	25.40	4.24	1.5	11.9
RX 37	159.94	11.91	6.45	25.40	4.24	1.5	11.9
RX 39	172.64	11.91	6.45	25.40	4.24	1.5	11.9
RX 41	191.69	11.91	6.45	25.40	4.24	1.5	11.9
RX 44	204.39	11.91	6.45	25.40	4.24	1.5	11.9
RX 45	221.84	11.91	6.45	25.40	4.24	1.5	11.9
RX 46	222.25	13.49	6.68	28.58	4.78	1.5	11.9
RX 49	280.59	11.91	6.45	25.40	4.24	1.5	11.9
RX 50	283.36	16.66	8.51	31.75	5.28	1.5	11.9
RX 53	334.57	11.91	6.45	25.40	4.24	1.5	11.9
RX 54	337.34	16.66	8.51	31.75	5.28	1.5	11.9
RX 57	391.72	11.91	6.45	25.40	4.24	1.5	11.9
RX 65	480.62	11.91	6.45	25.40	4.24	1.5	11.9
RX 66	483.39	16.66	8.51	31.75	5.28	1.5	11.9
RX 73	596.11	13.49	6.68	31.75	5.28	1.5	15.0
RX 74	600.86	19.84	10.34	41.28	6.88	2.3	18.3

FOOTNOTE

^a The variation in width *A* or height *H* of any ring shall not exceed 0.10 mm throughout its entire circumference.

Table D.11—Type BX Ring Grooves

Dimensions in millimeters; surface roughness in micrometers

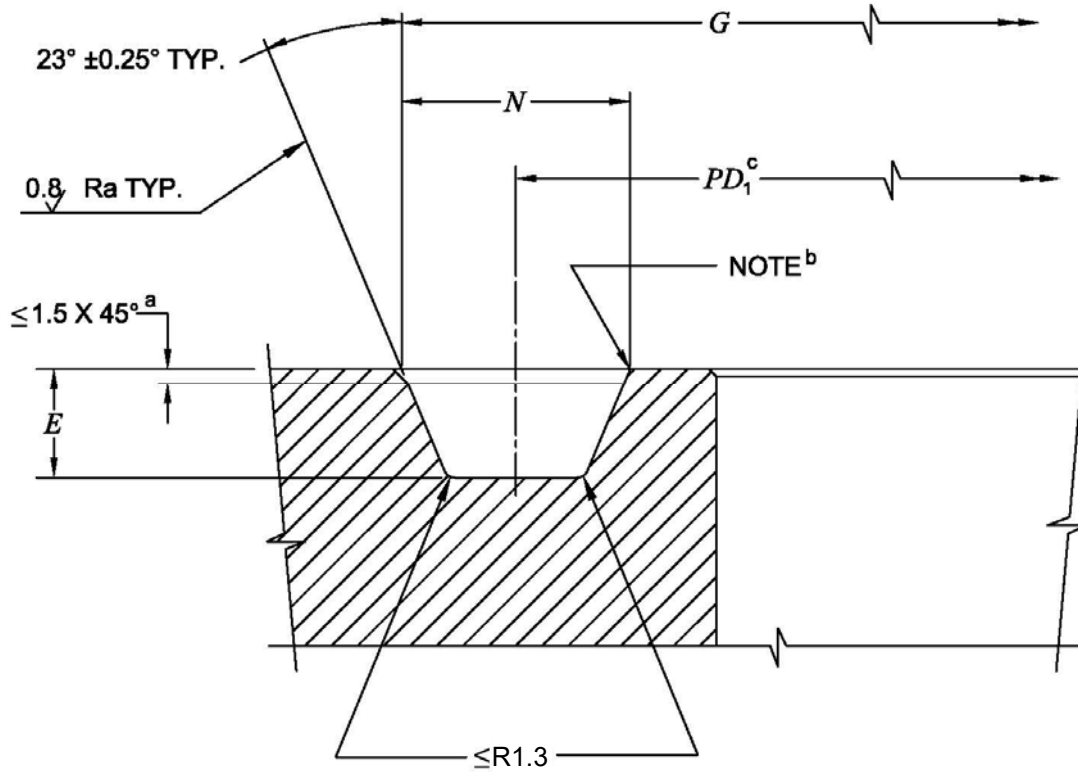

FOOTNOTES

- ^a The 1.5 x 45° chamfer is optional and only applies to the outside (OD) of the groove.
- ^b Break sharp corner 0.8 mm maximum at inside (ID) of the groove.
- ^c Reference dimension.

Table D.11—Type BX Ring Grooves (continued)

Dimensions in millimeters unless noted otherwise

Groove Number	Nominal Size of Flange	Outside Diameter of Groove	Depth of Groove	Width of Groove	Pitch Diameter of Groove	Pitch Diameter of Gasket ^a
	in.	<i>G</i>	<i>E</i>	<i>N</i>	<i>PD</i> ₁	<i>PD</i> ₂
Tolerance >	(Ref.)	+0.10/-0	+0.50/-0	+0.10/-0	(Ref.)	(Ref.)
BX 151	1 ¹³ / ₁₆	77.77	5.56	11.84	65.93	66.60
BX 152	2 ¹ / ₁₆	86.23	5.95	12.65	73.58	74.27
BX 153	2 ⁹ / ₁₆	102.77	6.75	14.07	88.70	89.39
BX 154	3 ¹ / ₁₆	119.00	7.54	15.39	103.61	104.27
BX 155	4 ¹ / ₁₆	150.62	8.33	17.73	132.89	133.57
BX 156	7 ¹ / ₁₆	241.83	11.11	23.39	218.44	219.13
BX 157	9	299.06	12.70	26.39	272.67	273.31
BX 158	11	357.23	14.29	29.18	328.05	328.73
BX 159	13 ⁵ / ₈	432.64	15.88	32.49	400.15	400.85
BX 160	13 ⁵ / ₈	408.00	14.29	19.96	388.04	388.68
BX 161	16 ³ / ₄	497.94	17.07	23.62	474.32	475.03
BX 162	16 ³ / ₄	478.33	8.33	17.91	460.42	461.10
BX 163	18 ³ / ₄	563.50	18.26	25.55	537.95	538.62
BX 164	18 ³ / ₄	577.90	18.26	32.77	545.13	545.80
BX 165	21 ¹ / ₄	632.56	19.05	27.20	605.36	606.05
BX 166	21 ¹ / ₄	647.88	19.05	34.87	613.01	613.72
BX 167	26 ³ / ₄	768.33	21.43	22.91	745.42	746.08
BX 168	26 ³ / ₄	774.22	21.43	25.86	748.36	749.03
BX 169	5 ¹ / ₈	176.66	9.53	16.92	159.74	160.41
BX 170	9	220.88	8.33	17.91	202.97	203.64
BX 171	11	270.28	8.33	17.91	252.37	253.05
BX 172	13 ⁵ / ₈	335.92	8.33	17.91	318.01	318.68
BX 303	30	862.30	22.62	27.38	834.92	835.61

FOOTNOTE
^a *PD*₂ of gaskets provided for comparison purposes. See Table E.12 for ring gasket dimensions.
Pitch diameter calculated using dimensions at middle of tolerance range.

Table D.12—Type BX Ring Gaskets

Dimensions in millimeters; surface roughness in micrometers

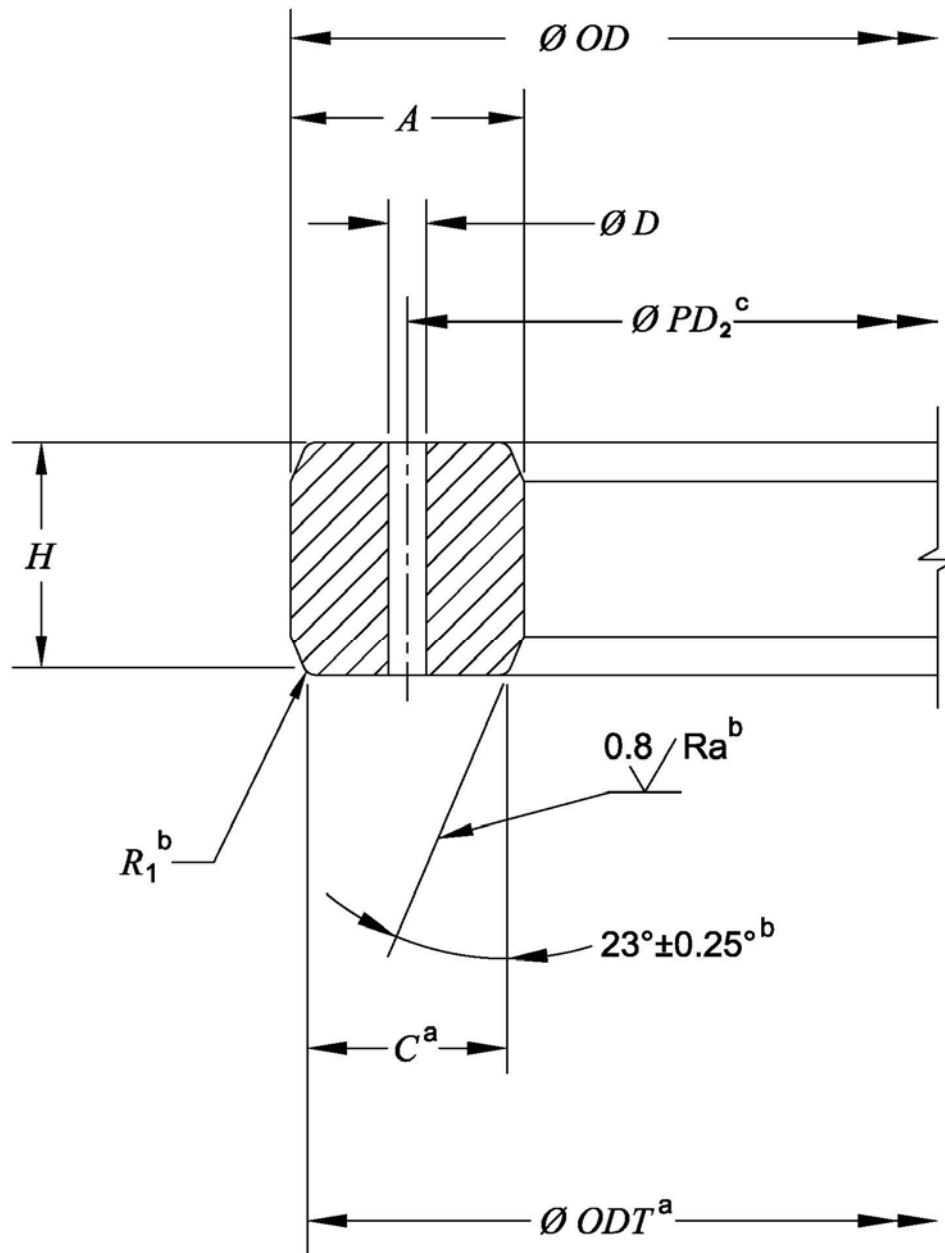

FOOTNOTES

- ^a Typical two places (top and bottom).
^b Typical four places (all corners).
^c Reference dimension (see Table D.11 for value).

Table D.12—Type BX Ring Gaskets (continued)

Dimensions in millimeters unless noted otherwise

Groove Number	Outside Diameter	Width of Ring ^a	Height of Ring ^a	Diameter of Flat	Width of Flat	Hole Size	Radius on Ring	
	<i>OD</i>	<i>A</i>	<i>H</i>	<i>ODT</i>	<i>C</i>	<i>D</i>	<i>R</i> ₁	
Tolerance>	+0/-0.15	+0.20/-0	+0.20/-0	± 0.05	+0.15/-0	± 0.5	min.	max.
BX 151	76.40	9.63	9.63	75.03	8.26	1.6	0.8	1.2
BX 152	84.68	10.24	10.24	83.24	8.79	1.6	0.8	1.2
BX 153	100.94	11.38	11.38	99.31	9.78	1.6	0.9	1.4
BX 154	116.84	12.40	12.40	115.09	10.64	1.6	1.0	1.5
BX 155	147.96	14.22	14.22	145.95	12.22	1.6	1.1	1.7
BX 156	237.92	18.62	18.62	235.28	15.98	3.2	1.5	2.2
BX 157	294.46	20.98	20.98	291.49	18.01	3.2	1.7	2.5
BX 158	352.04	23.14	23.14	348.77	19.86	3.2	1.9	2.8
BX 159	426.72	25.70	25.70	423.09	22.07	3.2	2.1	3.1
BX 160	402.59	13.74	23.83	399.21	10.36	3.2	1.9	2.9
BX 161	491.41	16.21	28.07	487.45	12.24	3.2	2.2	3.4
BX 162	475.49	14.22	14.22	473.48	12.22	1.6	1.1	1.7
BX 163	556.16	17.37	30.10	551.89	13.11	3.2	2.4	3.6
BX 164	570.56	24.59	30.10	566.29	20.32	3.2	2.4	3.6
BX 165	624.71	18.49	32.03	620.19	13.97	3.2	2.6	3.8
BX 166	640.03	26.14	32.03	635.51	21.62	3.2	2.6	3.8
BX 167	759.36	13.11	35.87	754.28	8.03	1.6	2.9	4.3
BX 168	765.25	16.05	35.87	760.17	10.97	1.6	2.9	4.3
BX 169	173.51	12.93	15.85	171.27	10.69	1.6	1.3	1.9
BX 170	218.03	14.22	14.22	216.03	12.22	1.6	1.1	1.7
BX 171	267.44	14.22	14.22	265.43	12.22	1.6	1.1	1.7
BX 172	333.07	14.22	14.22	331.06	12.22	1.6	1.1	1.7
BX 303	852.75	16.97	37.95	847.37	11.61	1.6	3.0	4.6

FOOTNOTE

^a The variation of width *A* or height *H* of any ring shall not exceed 0.10 mm throughout its entire circumference.

Table D.13—Flanged Crosses and Tees

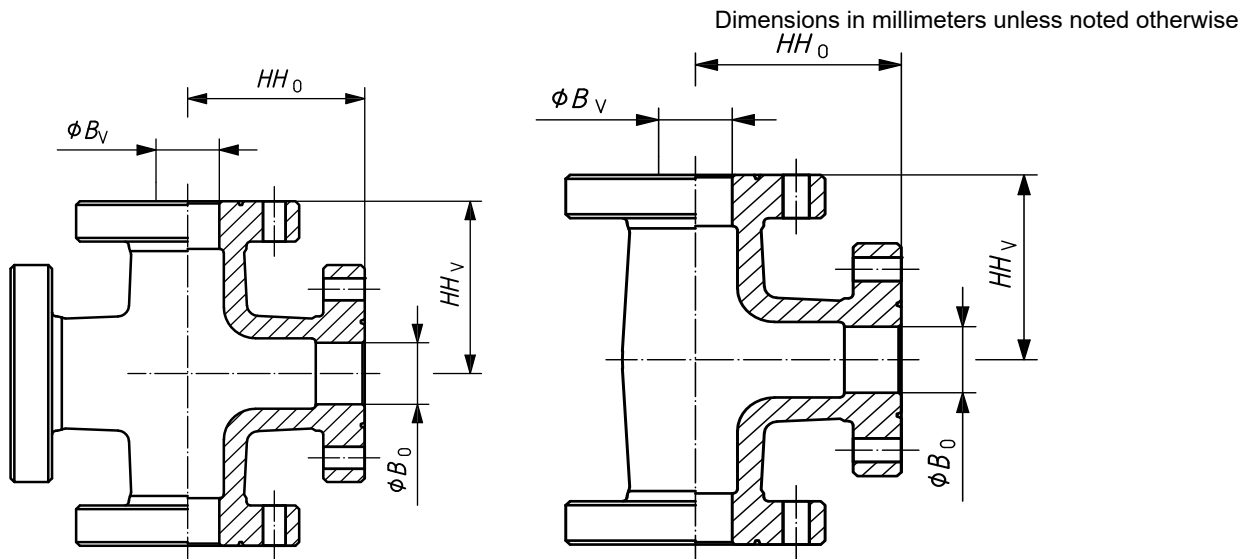

Nominal Sizes	Bore Diameter		Center-to-face Vertical Run HH_V	Center-to-face Horizontal Run HH_O
	Vertical Run B_V	Horizontal Run B_O		
Tolerance>	+0.8/-0	+0.8/-0	± 0.8	± 0.8
13.8 MPa				
$2^{1/16} \times 2^{1/16}$	52.3	52.3	147.5	147.5
$2^{9/16} \times 2^{1/16}$	65.0	52.3	151.0	160.5
$2^{9/16} \times 2^{9/16}$	65.0	65.0	166.5	166.5
$3^{1/8} \times 2^{1/16}$	79.3	52.3	154.0	170.0
$3^{1/8} \times 2^{9/16}$	79.3	65.0	166.5	173.0
$3^{1/8} \times 3^{1/8}$	79.3	79.3	179.5	179.5
$4^{1/16} \times 2^{1/16}$	103.1	52.3	160.5	201.5
$4^{1/16} \times 2^{9/16}$	103.1	65.0	173.0	205.0
$4^{1/16} \times 3^{1/8}$	103.1	79.3	182.5	208.0
$4^{1/16} \times 4^{1/16}$	103.1	103.1	217.5	217.5
20.7 MPa				
$2^{1/16} \times 2^{1/16}$	52.3	52.3	185.5	185.5
$2^{9/16} \times 2^{1/16}$	65.0	52.3	189.0	200.0
$2^{9/16} \times 2^{9/16}$	65.0	65.0	211.0	211.0
$3^{1/8} \times 2^{1/16}$	79.3	52.3	185.5	198.5
$3^{1/8} \times 2^{9/16}$	79.3	65.0	200.0	201.5
$3^{1/8} \times 3^{1/8}$	79.3	79.3	192.0	192.0
$4^{1/16} \times 2^{1/16}$	103.1	52.3	192.0	224.0
$4^{1/16} \times 2^{9/16}$	103.1	65.0	206.5	227.0
$4^{1/16} \times 3^{1/8}$	103.1	79.3	205.0	224.0
$4^{1/16} \times 4^{1/16}$	103.1	103.1	230.0	230.0

Table D.13—Flanged Crosses and Tees (continued)

Dimensions in millimeters unless noted otherwise

Nominal Sizes	Bore Diameter		Center-to-face Vertical Run HH_V	Center-to-face Horizontal Run HH_O
	Vertical Run B_V	Horizontal Run B_O		
Tolerance>	+0.8/-0	+0.8/-0	± 0.8	± 0.8
34.5 MPa				
2 ¹ / ₁₆ X 2 ¹ / ₁₆	52.3	52.3	185.5	185.5
2 ⁹ / ₁₆ X 2 ¹ / ₁₆	65.0	52.3	189.0	200.0
2 ⁹ / ₁₆ X 2 ⁹ / ₁₆	65.0	65.0	211.0	211.0
3 ¹ / ₈ X 2 ¹ / ₁₆	79.3	52.3	195.5	211.0
3 ¹ / ₈ X 2 ⁹ / ₁₆	79.3	65.0	209.5	214.5
3 ¹ / ₈ X 3 ¹ / ₈	79.3	79.3	236.5	236.5
4 ¹ / ₁₆ X 2 ¹ / ₁₆	103.1	52.3	201.5	233.5
4 ¹ / ₁₆ X 2 ⁹ / ₁₆	103.1	65.0	216.0	236.5
4 ¹ / ₁₆ X 3 ¹ / ₈	103.1	79.3	227.0	243.0
4 ¹ / ₁₆ X 4 ¹ / ₁₆	103.1	103.1	274.5	274.5
5 ¹ / ₈ X 2 ¹ / ₁₆	130.1 ^a	52.3	230.0	268.5
5 ¹ / ₈ X 2 ⁹ / ₁₆	130.1 ^a	65.0	244.5	271.5
5 ¹ / ₈ X 3 ¹ / ₈	130.1 ^a	79.3	255.5	278.0
5 ¹ / ₈ X 4 ¹ / ₁₆	130.1 ^a	103.1	278.0	284.0
5 ¹ / ₈ X 5 ¹ / ₈	130.1 ^a	130.1 ^a	309.5	309.5
69.0 MPa				
2 ¹ / ₁₆ X 1 ¹³ / ₁₆	52.3	46.0	169.5	174.0
2 ¹ / ₁₆ X 2 ¹ / ₁₆	52.3	52.3	176.0	176.0
2 ⁹ / ₁₆ X 1 ¹³ / ₁₆	65.0	46.0	176.5	189.5
2 ⁹ / ₁₆ X 2 ¹ / ₁₆	65.0	52.3	183.0	191.5
2 ⁹ / ₁₆ X 2 ⁹ / ₁₆	65.0	65.0	199.0	199.0
3 ¹ / ₁₆ X 1 ¹³ / ₁₆	77.7	46.0	183.5	209.0
3 ¹ / ₁₆ X 2 ¹ / ₁₆	77.7	52.3	190.0	210.5
3 ¹ / ₁₆ X 2 ⁹ / ₁₆	77.7	65.0	206.0	218.0
3 ¹ / ₁₆ X 3 ¹ / ₁₆	77.7	77.7	225.0	225.0
4 ¹ / ₁₆ X 1 ¹³ / ₁₆	103.1	46.0	198.5	235.0
4 ¹ / ₁₆ X 2 ¹ / ₁₆	103.1	52.3	205.0	237.0
4 ¹ / ₁₆ X 2 ⁹ / ₁₆	103.1	65.0	220.5	244.0
4 ¹ / ₁₆ X 3 ¹ / ₁₆	103.1	77.7	239.5	251.0
4 ¹ / ₁₆ X 4 ¹ / ₁₆	103.1	103.1	262.5	262.5
5 ¹ / ₈ X 1 ¹³ / ₁₆	130.1 ^a	46.0	208.0	255.5
5 ¹ / ₈ X 2 ¹ / ₁₆	130.1 ^a	52.3	214.5	257.0
5 ¹ / ₈ X 2 ⁹ / ₁₆	130.1 ^a	65.0	230.0	264.5
5 ¹ / ₈ X 3 ¹ / ₁₆	130.1 ^a	77.7	249.0	271.5
5 ¹ / ₈ X 4 ¹ / ₁₆	130.1 ^a	103.1	272.5	284.0
5 ¹ / ₈ X 5 ¹ / ₈	130.1 ^a	130.1 ^a	293.0	293.0
FOOTNOTE				
^a Tolerance on 5 ¹ / ₈ bore is +1.0/-0.				

Table D.13—Flanged Crosses and Tees (continued)

Dimensions in millimeters unless noted otherwise

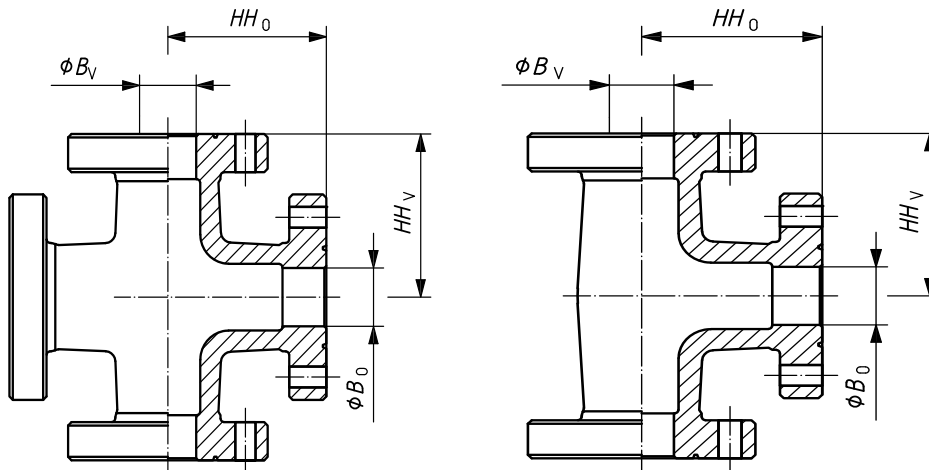

Nominal Sizes	Bore Diameter		Center-to-face Vertical Run HH_V	Center-to-face Horizontal Run HH_O
	Vertical Run B_V	Horizontal Run B_O		
Tolerance>	+0.8/-0	+0.8/-0	± 0.8	± 0.8
103.5 MPa				
$2^{1/16} \times 1^{13/16}$	52.3	46.0	186.5	188.0
$2^{1/16} \times 2^{1/16}$	52.3	52.3	193.5	193.5
$2^{9/16} \times 1^{13/16}$	65.0	46.0	193.0	204.0
$2^{9/16} \times 2^{1/16}$	65.0	52.3	200.0	209.5
$2^{9/16} \times 2^{9/16}$	65.0	65.0	216.0	216.0
$3^{1/16} \times 1^{13/16}$	77.7	46.0	199.5	220.5
$3^{1/16} \times 2^{1/16}$	77.7	52.3	207.0	226.0
$3^{1/16} \times 2^{9/16}$	77.7	65.0	223.0	232.5
$3^{1/16} \times 3^{1/16}$	77.7	77.7	239.5	239.5
$4^{1/16} \times 1^{13/16}$	103.1	46.0	220.5	260.5
$4^{1/16} \times 2^{1/16}$	103.1	52.3	228.0	266.0
$4^{1/16} \times 2^{9/16}$	103.1	65.0	243.5	272.5
$4^{1/16} \times 3^{1/16}$	103.1	77.7	260.5	279.5
$4^{1/16} \times 4^{1/16}$	103.1	103.1	297.0	297.0
$5^{1/8} \times 1^{13/16}$	130.1 ^a	46.0	238.0	290.5
$5^{1/8} \times 2^{1/16}$	130.1 ^a	52.3	244.5	295.5
$5^{1/8} \times 2^{9/16}$	130.1 ^a	65.0	260.5	301.5
$5^{1/8} \times 3^{1/16}$	130.1 ^a	77.7	278.0	309.5
$5^{1/8} \times 4^{1/16}$	130.1 ^a	103.1	314.5	324.0
$5^{1/8} \times 5^{1/8}$	130.1 ^a	130.1 ^a	343.0	343.0
FOOTNOTE				
^a Tolerance on $5^{1/8}$ bore is +1.0/-0.				

Table D.13—Flanged Crosses and Tees (continued)

Dimensions in millimeters unless noted otherwise

Nominal Sizes	Bore Diameter		Center-to-face Vertical Run HH_V	Center-to-face Horizontal Run HH_O
	Vertical Run B_V	Horizontal Run B_O		
Tolerance>	+0.8/-0	+0.8/-0	± 0.8	± 0.8
138.0 MPa				
$1^{13/16} \times 1^{13/16}$	46.0	46.0	227.0	227.0
$2^{1/16} \times 1^{13/16}$	52.3	46.0	235.0	242.0
$2^{1/16} \times 2^{1/16}$	52.3	52.3	250.0	250.0
$2^{9/16} \times 1^{13/16}$	65.0	46.0	243.0	261.0
$2^{9/16} \times 2^{1/16}$	65.0	52.3	258.0	269.0
$2^{9/16} \times 2^{9/16}$	65.0	65.0	277.0	277.0
$3^{1/16} \times 1^{13/16}$	77.7	46.0	252.5	277.0
$3^{1/16} \times 2^{1/16}$	77.7	52.3	267.5	259.5
$3^{1/16} \times 2^{9/16}$	77.7	65.0	286.5	293.0
$3^{1/16} \times 3^{1/16}$	77.7	77.7	302.5	302.5
$4^{1/16} \times 1^{13/16}$	103.1	46.0	282.5	321.5
$4^{1/16} \times 2^{1/16}$	103.1	52.3	297.5	321.5
$4^{1/16} \times 2^{9/16}$	103.1	65.0	316.5	337.5
$4^{1/16} \times 3^{1/16}$	103.1	77.7	332.5	347.0
$4^{1/16} \times 4^{1/16}$	103.1	103.1	377.0	377.0

Table D.14—Studded Crosses and Tees

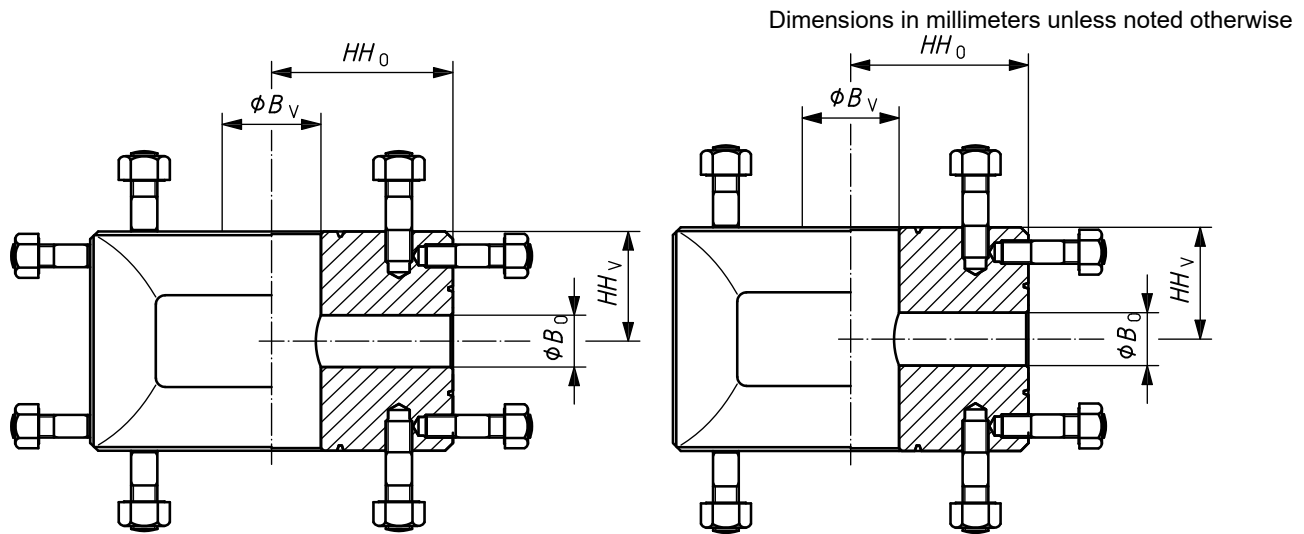

Nominal Sizes	Bore Diameter		Center-to-face Vertical Run HH_V	Center-to-face Horizontal Run HH_O
	Vertical Run B_V	Horizontal Run B_O		
Tolerance>	+0.8/-0	+0.8/-0	± 0.8	± 0.8
13.8 MPa				
$2^{1/16} \times 2^{1/16}$	52.3	52.3	89.0	89.0
$2^{9/16} \times 2^{1/16}$	65.0	52.3	89.0	101.5
$2^{9/16} \times 2^{9/16}$	65.0	65.0	114.5	114.5
$3^{1/8} \times 2^{1/16}$	79.3	52.3	89.0	114.5
$3^{1/8} \times 2^{9/16}$	79.3	65.0	114.5	114.5
$3^{1/8} \times 3^{1/8}$	79.3	79.3	114.5	114.5
$4^{1/16} \times 2^{1/16}$	103.1	52.3	114.5	139.5
$4^{1/16} \times 2^{9/16}$	103.1	65.0	114.5	139.5
$4^{1/16} \times 3^{1/8}$	103.1	79.3	114.5	139.5
$4^{1/16} \times 4^{1/16}$	103.1	103.1	139.5	139.5
20.7 MPa				
$2^{1/16} \times 2^{1/16}$	52.3	52.3	114.5	114.5
$2^{9/16} \times 2^{1/16}$	65.0	52.3	114.5	127.0
$2^{9/16} \times 2^{9/16}$	65.0	65.0	127.0	127.0
$3^{1/8} \times 2^{1/16}$	79.3	52.3	114.5	127.0
$3^{1/8} \times 2^{9/16}$	79.3	65.0	127.0	127.0
$3^{1/8} \times 3^{1/8}$	79.3	79.3	127.0	127.0
$4^{1/16} \times 2^{1/16}$	103.1	52.3	114.5	155.5
$4^{1/16} \times 2^{9/16}$	103.1	65.0	127.0	155.5
$4^{1/16} \times 3^{1/8}$	103.1	79.3	127.0	155.5
$4^{1/16} \times 4^{1/16}$	103.1	103.1	155.5	155.5

Table D.14—Studded Crosses and Tees (continued)

Dimensions in millimeters unless noted otherwise

Nominal Sizes	Bore Diameter		Center-to-face Vertical Run HH_V	Center-to-face Horizontal Run HH_O
	Vertical Run B_V	Horizontal Run B_O		
Tolerance>	+0.8/-0	+0.8/-0	± 0.8	± 0.8
34.5 MPa				
2 ¹ / ₁₆ x 2 ¹ / ₁₆	52.3	52.3	114.5	114.5
2 ⁹ / ₁₆ x 2 ¹ / ₁₆	65.0	52.3	114.5	127.0
2 ⁹ / ₁₆ x 2 ⁹ / ₁₆	65.0	65.0	127.0	127.0
3 ¹ / ₈ x 2 ¹ / ₁₆	79.3	52.3	114.5	139.5
3 ¹ / ₈ x 2 ⁹ / ₁₆	79.3	65.0	139.5	139.5
3 ¹ / ₈ x 3 ¹ / ₈	79.3	79.3	139.5	139.5
4 ¹ / ₁₆ x 2 ¹ / ₁₆	103.1	52.3	114.5	165.0
4 ¹ / ₁₆ x 2 ⁹ / ₁₆	103.1	65.0	127.0	165.0
4 ¹ / ₁₆ x 3 ¹ / ₈	103.1	79.3	139.5	165.0
4 ¹ / ₁₆ x 4 ¹ / ₁₆	103.1	103.1	165.0	165.0
5 ¹ / ₈ x 2 ¹ / ₁₆	130.1 ^a	52.3	155.5	193.5
5 ¹ / ₈ x 2 ⁹ / ₁₆	130.1 ^a	65	155.5	193.5
5 ¹ / ₈ x 3 ¹ / ₈	130.1 ^a	79.3	155.5	193.5
5 ¹ / ₈ x 4 ¹ / ₁₆	130.1 ^a	103.1	202.5	202.5
5 ¹ / ₈ x 5 ¹ / ₈	130.1 ^a	130.1 ^a	202.5	202.5
69.0 MPa				
1 ¹³ / ₁₆ x 1 ¹³ / ₁₆	46.0	46.0	111.0	111.0
2 ¹ / ₁₆ x 1 ¹³ / ₁₆	52.3	46.0	111.0	111.0
2 ¹ / ₁₆ x 2 ¹ / ₁₆	52.3	52.3	111.0	111.0
2 ⁹ / ₁₆ x 1 ¹³ / ₁₆	65.0	46.0	114.5	130.0
2 ⁹ / ₁₆ x 2 ¹ / ₁₆	65.0	52.3	114.5	130.0
2 ⁹ / ₁₆ x 2 ⁹ / ₁₆	65.0	65.0	130.0	130.0
3 ¹ / ₁₆ x 1 ¹³ / ₁₆	77.7	46.0	114.5	149.0
3 ¹ / ₁₆ x 2 ¹ / ₁₆	77.7	52.3	114.5	149.0
3 ¹ / ₁₆ x 2 ⁹ / ₁₆	77.7	65.0	130.0	149.0
3 ¹ / ₁₆ x 3 ¹ / ₁₆	77.7	77.7	149.0	149.0
4 ¹ / ₁₆ x 1 ¹³ / ₁₆	103.1	46.0	114.5	174.5
4 ¹ / ₁₆ x 2 ¹ / ₁₆	103.1	52.3	114.5	174.5
4 ¹ / ₁₆ x 2 ⁹ / ₁₆	103.1	65.0	130.0	174.5
4 ¹ / ₁₆ x 3 ¹ / ₁₆	103.1	77.7	149.0	174.5
4 ¹ / ₁₆ x 4 ¹ / ₁₆	103.1	103.1	174.5	174.5
5 ¹ / ₈ x 1 ¹³ / ₁₆	130.1 ^a	46.0	133.5	197.0
5 ¹ / ₈ x 2 ¹ / ₁₆	130.1 ^a	52.3	133.5	197.0
5 ¹ / ₈ x 2 ⁹ / ₁₆	130.1 ^a	65.0	133.5	197.0
5 ¹ / ₈ x 3 ¹ / ₁₆	130.1 ^a	77.7	171.5	197.0
5 ¹ / ₈ x 4 ¹ / ₁₆	130.1 ^a	103.1	171.5	197.0
5 ¹ / ₈ x 5 ¹ / ₈	130.1 ^a	130.1 ^a	197.0	197.0
FOOTNOTE				
^a Tolerance on 5 ¹ / ₈ bore is +1.0/-0.				

Table D.14—Studded Crosses and Tees (continued)

Dimensions in millimeters unless noted otherwise

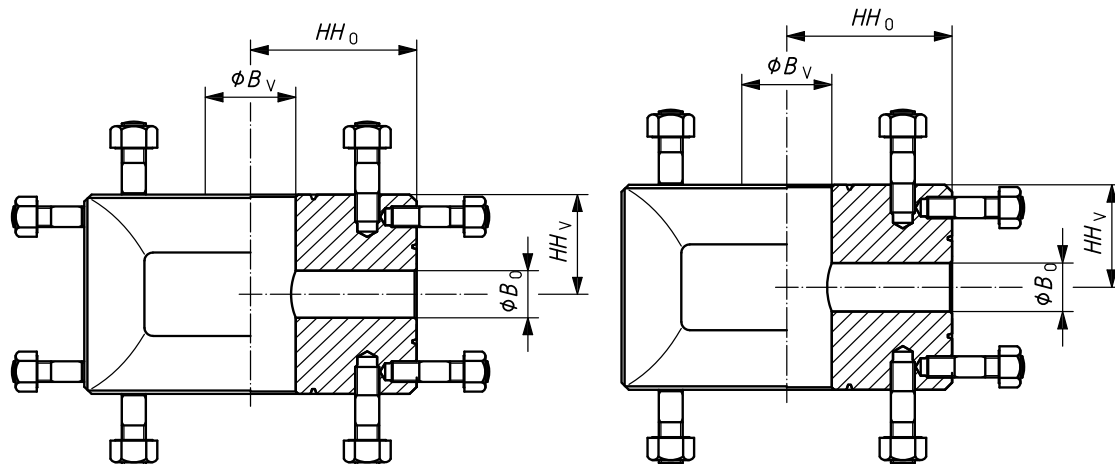

Nominal Sizes	Bore Diameter		Center-to-face Vertical Run HH_V	Center-to-face Horizontal Run HH_O
	Vertical Run B_V	Horizontal Run B_O		
Tolerance>	+0.8/-0	+0.8/-0	± 0.8	± 0.8
103.5 MPa				
$1^{13}/_{16} \times 1^{13}/_{16}$	46.0	46.0	127.0	127.0
$2^{1}/_{16} \times 1^{13}/_{16}$	52.3	46.0	127.0	127.0
$2^{1}/_{16} \times 2^{1}/_{16}$	52.3	52.3	127.0	127.0
$2^{9}/_{16} \times 1^{13}/_{16}$	65.0	46.0	139.5	139.5
$2^{9}/_{16} \times 2^{1}/_{16}$	65.0	52.3	139.5	139.5
$2^{9}/_{16} \times 2^{9}/_{16}$	65.0	65.0	139.5	139.5
$3^{1}/_{16} \times 1^{13}/_{16}$	77.7	46.0	160.5	160.5
$3^{1}/_{16} \times 2^{1}/_{16}$	77.7	52.3	160.5	160.5
$3^{1}/_{16} \times 2^{9}/_{16}$	77.7	65.0	160.5	160.5
$3^{1}/_{16} \times 3^{1}/_{16}$	77.7	77.7	160.5	160.5
$4^{1}/_{16} \times 1^{13}/_{16}$	103.1	46.0	193.5	193.5
$4^{1}/_{16} \times 2^{1}/_{16}$	103.1	52.3	193.5	193.5
$4^{1}/_{16} \times 2^{9}/_{16}$	103.1	65.0	193.5	193.5
$4^{1}/_{16} \times 3^{1}/_{16}$	103.1	77.7	193.5	193.5
$4^{1}/_{16} \times 4^{1}/_{16}$	103.1	103.1	193.5	193.5
$5^{1}/_{8} \times 1^{13}/_{16}$	130.1 ^a	46.0	168.0	222.0
$5^{1}/_{8} \times 2^{1}/_{16}$	130.1 ^a	52.3	168.0	222.0
$5^{1}/_{8} \times 2^{9}/_{16}$	130.1 ^a	65.0	168.0	222.0
$5^{1}/_{8} \times 3^{1}/_{16}$	130.1 ^a	77.7	168.0	222.0
$5^{1}/_{8} \times 4^{1}/_{16}$	130.1 ^a	103.1	235.0	235.0
$5^{1}/_{8} \times 5^{1}/_{8}$	130.1 ^a	130.1 ^a	235.0	235.0
FOOTNOTE				
^a Tolerance on $5^{1}/_{8}$ bore is +1.0/-0.				

Table D.14—Studded Crosses and Tees (continued)

Dimensions in millimeters unless noted otherwise

Nominal Sizes	Bore Diameter		Center-to-face Vertical Run HH_V	Center-to-face Horizontal Run HH_O
	Vertical Run B_V	Horizontal Run B_O		
Tolerance>	+0.8/-0	+0.8/-0	± 0.8	± 0.8
138.0 MPa				
1 ¹³ / ₁₆ X 1 ¹³ / ₁₆	46.0	46.0	164.5	164.5
2 ¹ / ₁₆ X 1 ¹³ / ₁₆	52.3	46.0	164.5	164.5
2 ¹ / ₁₆ X 2 ¹ / ₁₆	52.3	52.3	164.5	164.5
2 ⁹ / ₁₆ X 1 ¹³ / ₁₆	65.0	46.0	185.0	185.0
2 ⁹ / ₁₆ X 2 ¹ / ₁₆	65.0	52.3	185.0	185.0
2 ⁹ / ₁₆ X 2 ⁹ / ₁₆	65.0	65.0	185.0	185.0
3 ¹ / ₁₆ X 1 ¹³ / ₁₆	77.7	46.0	202.5	202.5
3 ¹ / ₁₆ X 2 ¹ / ₁₆	77.7	52.3	202.5	202.5
3 ¹ / ₁₆ X 2 ⁹ / ₁₆	77.7	65.0	202.5	202.5
3 ¹ / ₁₆ X 3 ¹ / ₁₆	77.7	77.7	202.5	202.5
4 ¹ / ₁₆ X 1 ¹³ / ₁₆	103.1	46.0	251.5	251.5
4 ¹ / ₁₆ X 2 ¹ / ₁₆	103.1	52.3	251.5	251.5
4 ¹ / ₁₆ X 2 ⁹ / ₁₆	103.1	65.0	251.5	251.5
4 ¹ / ₁₆ X 3 ¹ / ₁₆	103.1	77.7	251.5	251.5
4 ¹ / ₁₆ X 4 ¹ / ₁₆	103.1	103.1	251.5	251.5

Table D.15—Bullplugs

Dimensions in millimeters unless noted otherwise

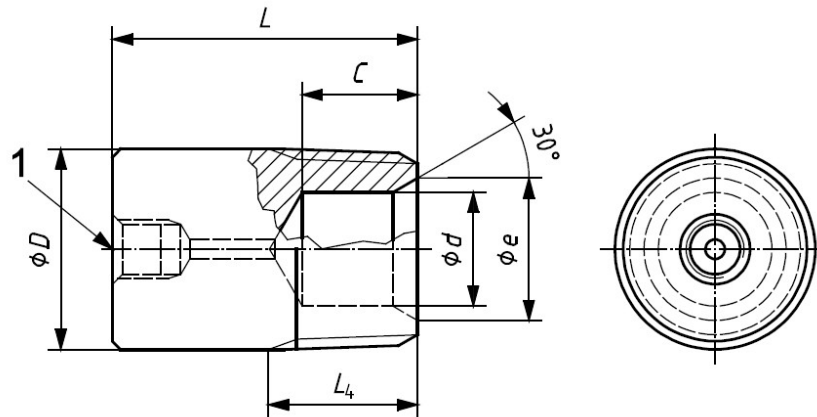
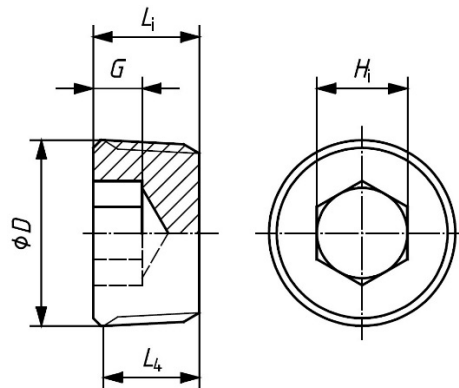
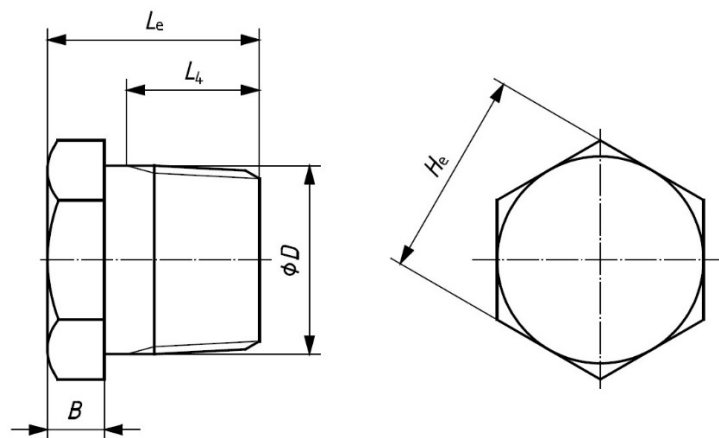
**a) Round plug****b) Plug with internal hex****c) Plug with external hex****Key**

1 test or gauge port (optional)

NOTE See API 5B for thread dimensions and tolerances.

Table D.15—Bullplugs (continued)

Dimensions in millimeters unless noted otherwise

		a), b), c) All Styles of Bullplugs					a) Round Plugs
Nominal Size	Outside Diameter		Minimum Length of Thread to Vanish Point	Depth of Counterbore	Diameter of Counterbore	Diameter of Chamfer	Overall Length
in.	<i>D</i>		<i>L₄</i>	<i>C</i>	<i>d</i>	<i>e</i>	<i>L</i>
Tolerance>	Value	Tolerance	min.	± 0.5	+1.0/-0	+0.5/-0	+1.0/-0
1/2	21.43	+0.20/-0	19.85	None	None	None	51.0
3/4	26.59	+0.20/-0	20.15	None	None	None	51.0
1	33.34	+0.25/-0	25.01	None	None	None	51.0
1 1/4	42.07	+0.25/-0	25.62	27.0	22.4	None	51.0
1 1/2	48.42	+0.25/-0	26.04	27.0	25.4	None	51.0
2	60.33	+0.25/-0	26.88	64.0	41.0	50.8	102.0
2 1/2	73.03	+0.25/-0	39.91	41.5	44.5	None	102.0
3	88.90	+0.25/-0	41.50	41.5	57.2	None	102.0
3 1/2	101.60	+0.25/-0	42.77	44.5	69.9	None	102.0
4	114.30	+0.25/-0	44.04	44.5	76.2	None	102.0

		b) Plugs with Internal Hex			c) Plugs with External Hex			
Nominal Size	Hex Size (Across Flats)		Depth of Hex	Overall Length	Hex Size (Across Flats)		Height of Hex	Overall Length
in.	<i>H_i</i>		<i>G</i>	<i>L_i</i>	<i>H_e</i>		<i>B</i>	<i>L_e</i>
Tolerance>	Value	Tolerance	+1.0/-0	+1.0/-0	Value	Tolerance	+1.0/-0	+1.0/-0
1/2	9.70	+0/-0.10	7.9	25.4	22.20	+0/-0.64	7.9	28.7
3/4	14.20	+0/-0.13	7.9	25.4	27.00	+0/-0.79	9.7	31.8
1	16.00	+0/-0.15	9.7	25.4	34.90	+0/-1.04	9.7	35.1

Table D.16—VR Plug Dimensions, 13.8 MPa, 20.7 MPa, 34.5 MPa, and 69.0 MPa (continued)

Dimensions in millimeters unless noted otherwise

Nominal Outlet Size in.	Nominal Thread OD in. A	Threads per Inch TPI	Thread Type	Diameter at Large End B	Diameter at Small End C	Length of Taper D	Length of Full Thread E	Overall Length of Plug F	Chamfer Diameter G	Counter-bore Diameter L	Counter-bore Depth M
Tolerance>		(Ref.)	NA	± 0.12	± 0.12	(Ref.)	(Ref.)	± 0.8	± 0.4	± 0.4	± 0.8
1 ¹³ / ₁₆	1.660	11 ¹ / ₂	Line pipe	42.16	41.15	16.26	25.62	72.1	37.8	22.4	26.9
2 ¹ / ₁₆	1.900	11 ¹ / ₂	Sharp vee	48.26	46.59	26.70	34.93	80.3	43.2	25.4	26.9
2 ⁹ / ₁₆	2 ³ / ₈	11 ¹ / ₂	Sharp vee	60.33	58.26	33.04	41.28	86.6	54.9	38.1	26.9
3 ¹ / ₈ ^a	2 ⁷ / ₈	11 ¹ / ₂	Sharp vee	73.03	70.26	44.18	52.39	97.5	66.9	44.5	41.4
4 ¹ / ₁₆	3 ¹ / ₂	11 ¹ / ₂	Sharp vee	88.90	85.74	50.52	58.74	103.9	82.4	69.9	44.5

FOOTNOTES

^a 3¹/₁₆ in. bore for 69.0 MPa RWP.

NOTE 1 Thread taper for all sizes shall be 1-in-16 (reference 1° 47' 24" with the centerline).

NOTE 2 Tolerances on angles, unless otherwise noted, shall be ± 0.5 degrees.

Table D.17—VR Preparation Dimensions, 13.8 MPa, 20.7 MPa, 34.5 MPa, and 69.0 MPa

Dimensions in millimeters unless noted otherwise; surface roughness in micrometers

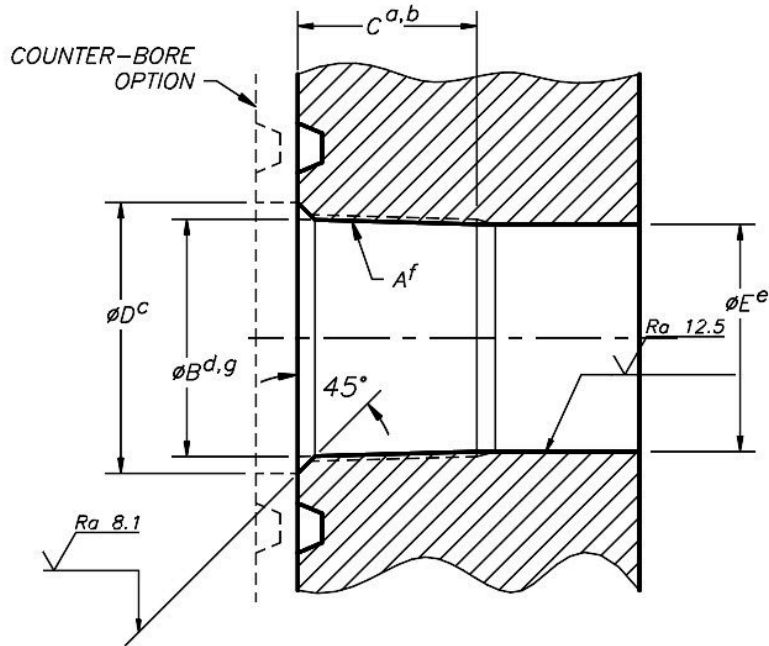

FOOTNOTES

- a Full thread.
- b Reference.
- c Diameter of counterbore or chamfer.
- d Thread bore.
- e Standard bore.
- f Thread.
- g Thread bore taken at face of flange, gauge thread from bottom of chamfer, counterbore is optional.

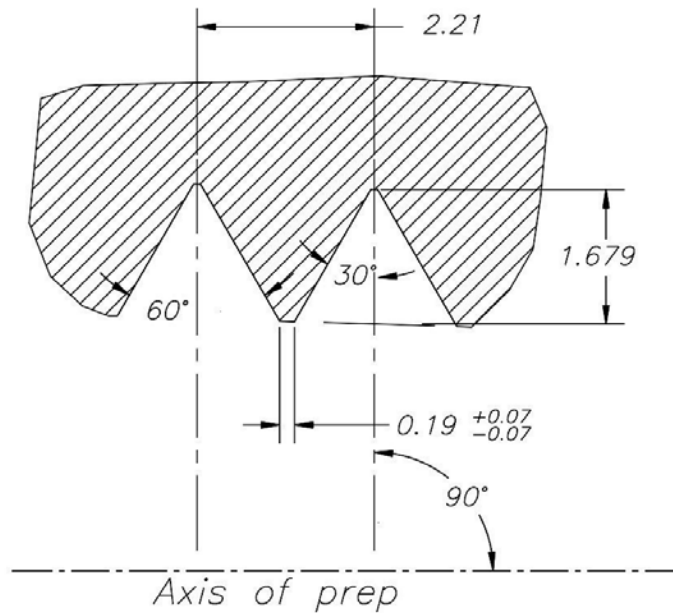

VR Preparation Thread Form Detail

Table D.17—VR Preparation Dimensions, 13.8 MPa, 20.7 MPa, 34.5 MPa, and 69.0 MPa (continued)

Dimensions in millimeters unless noted otherwise

Nominal Outlet Size	Nominal Thread OD <i>A</i>	Threads per Inch TPI	Thread Type	Thread Bore <i>B</i>	Full Thread Length <i>C</i>	Chamfer and Counterbore Diameter <i>D</i>	Straight Bore <i>E</i>
Tolerance>		(Ref.)	NA	± 0.13	(Ref.)	± 0.8	± 0.4
1 ¹³ / ₁₆	1.660	11 ¹ / ₂	Line pipe	38.96	27.4	49.3	36.8
2 ¹ / ₁₆	1.900	11 ¹ / ₂	Sharp vee	45.03	38.4	55.6	42.2
2 ⁹ / ₁₆	2 ³ / ₈	11 ¹ / ₂	Sharp vee	57.00	44.7	65.0	53.8
3 ¹ / ₈ ^a	2 ⁷ / ₈	11 ¹ / ₂	Sharp vee	69.65	55.9	77.7	65.7
4 ¹ / ₁₆	3 ¹ / ₂	11 ¹ / ₂	Sharp vee	85.83	62.2	103.1	81.5
FOOTNOTES ^a 3 ¹ / ₁₆ in. bore for 69.0 MPa RWP. NOTE Thread taper for all sizes shall be 1-in-16 (reference 1° 47' 24" with the centerline).							

Table D.18—VR Plug Thread Gauging Dimensions, 13.8 MPa, 20.7 MPa, 34.5 MPa, and 69.0 MPa

Dimensions in millimeters

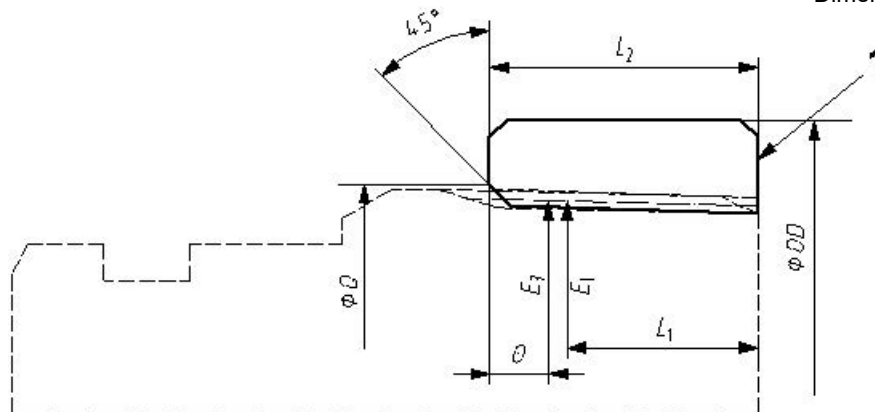
**Key**1 gauge standoff with end of VR plug: flush $\pm 1p$

NOTE "p" is defined as the distance from a point on a nominal thread form to a corresponding point on the next thread, measured parallel to the axis. This value can be calculated by dividing 1 mm by the number of threads per millimeter.

Nominal Size	Ring Gauge Outside Diameter <i>OD</i>	Ring Gauge Chamfer Diameter <i>Q</i>	Ring Gauge Length <i>L₂</i>	Face of Ring Gauge to Plane of Gauge Point <i>θ</i>
1 ¹³ / ₁₆	55.9	43.7	17.953	4.417
2 ¹ / ₁₆	63.5	49.8	28.918	5.037
2 ⁹ / ₁₆	77.7	62.0	35.268	5.037
3 ¹ / ₈ ^a	93.2	74.7	46.380	5.037
4 ¹ / ₁₆	114.3	90.4	52.730	5.037

FOOTNOTES

^a 3¹/₁₆ in. bore for 69.0 MPa RWP.

NOTE 1 See Table D.18 for location of dimensions.

NOTE 2 See Table D.19 for *E₇*, *E₁*, and *L₁*.

Table D.19—VR Preparation Thread Gauging Dimensions, 13.8 MPa, 20.7 MPa, 34.5 MPa, and 69.0 MPa

Dimensions in millimeters unless noted otherwise

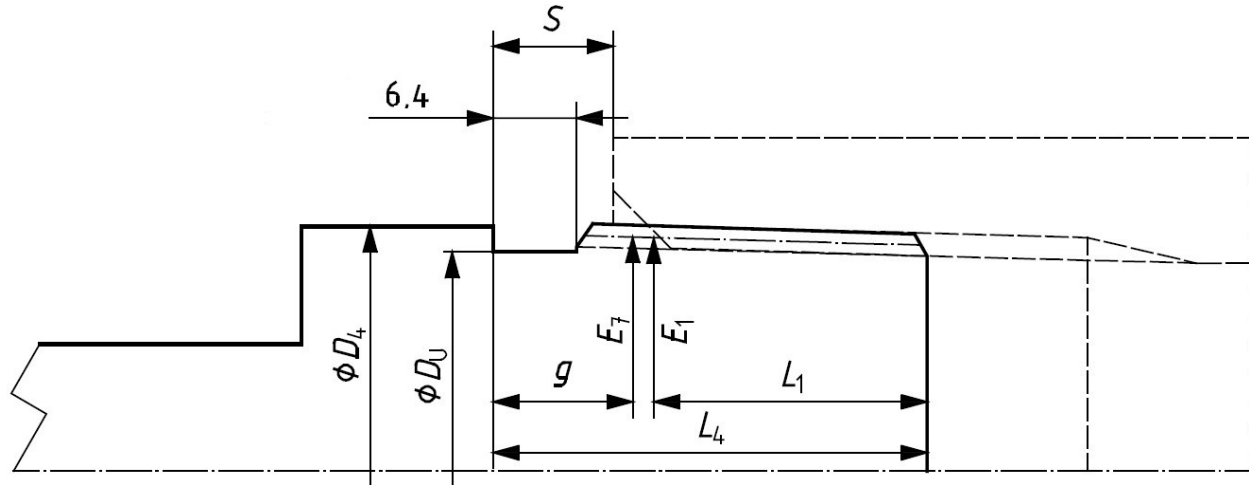

Nominal Outlet Size	Major Diameter	Diameter of Plug Gauge Groove	Threads per Inch	Length: End of Pipe to Hand-tight Plane	Pitch Diameter at Hand-tight Plane	Total Length: End of Pipe to Vanish Point	Length: Gauge Point to Vanish Point	Pitch Diameter at Gauge Point	Standoff
	D_4	D_U		L_1	E_1	L_4	g	E_7	S ± 2.21
1 ¹³ / ₁₆	42.2	37.1	11 ¹ / ₂	10.670	40.2179	25.616	12.080	39.0916	10.419
2 ¹ / ₁₆	48.3	43.1	11 ¹ / ₂	20.589	46.2874	34.925	11.044	46.4929	9.667
2 ⁹ / ₁₆	60.3	55.4	11 ¹ / ₂	26.507	58.3255	41.275	11.044	58.5579	11.417
3 ¹ / ₈ ^a	73.0	68.1	11 ¹ / ₂	36.927	70.9821	52.388	11.044	71.2579	12.090
4 ¹ / ₁₆	88.9	83.8	11 ¹ / ₂	43.277	86.8571	58.738	11.044	87.1329	7.328

FOOTNOTE

^a 3¹/₁₆ in. bore for 69.0 MPa RWP.

Table D.20—HPVR Plug Dimensions, 103.5 MPa and 138.0 MPa

Dimensions in millimeters unless noted otherwise; surface roughness in micrometers

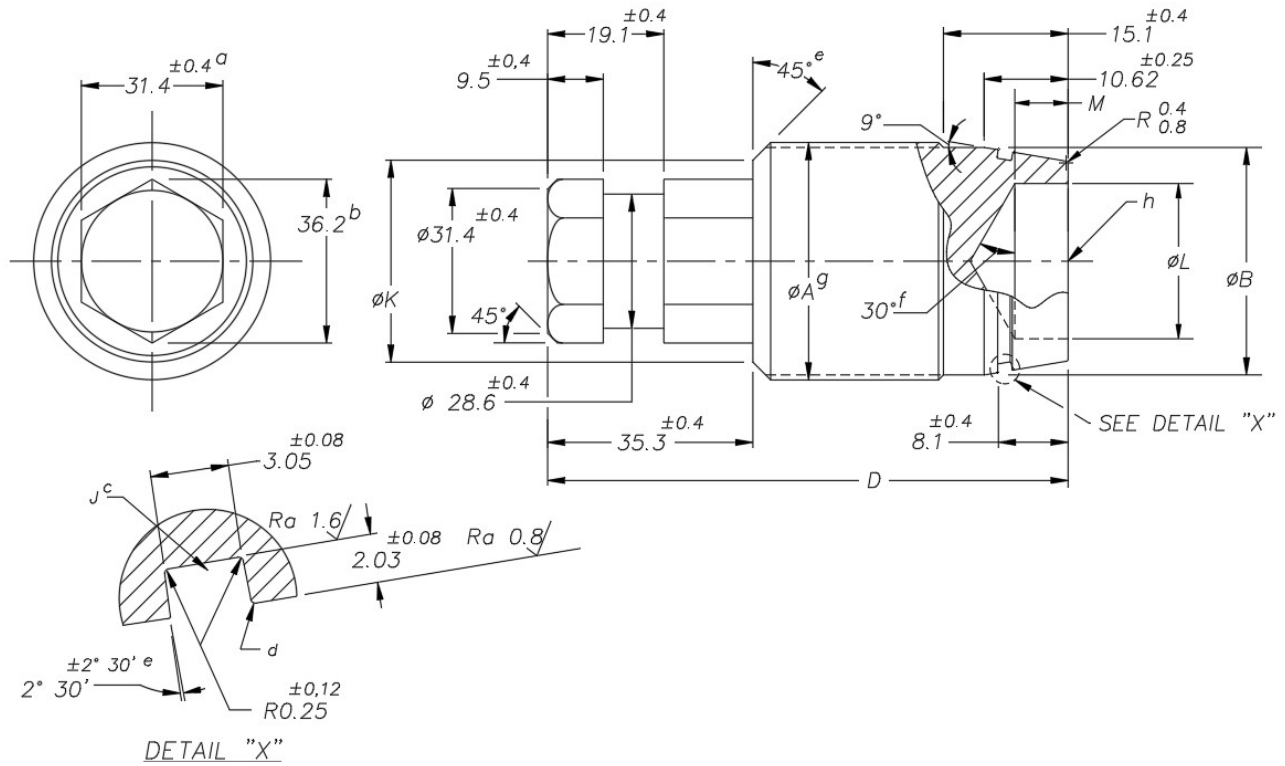

FOOTNOTES

- a Across flats.
- b Across corners.
- c Install (SAE AS568A O-ring size number).
- d Break corners approx. $R 0.12$.
- e Typical.
- f Optional.
- g Thread.
- h Drill L diameter, M deep.

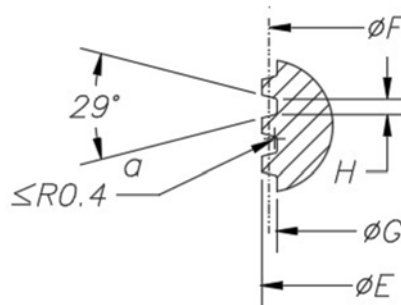

Thread Form Detail

FOOTNOTE

- a Typical for all full threads.

Table D.20—HPVR Plug Dimensions, 103.5 MPa and 138.0 MPa (continued)

Dimensions in millimeters unless noted otherwise

Nominal Outlet Size in.	Nominal Thread Size in.	Threads per Inch	Large Taper Diameter	Overall Length	SAE AS568A O-ring Size No.	Chamfer Diameter	Counterbore Diameter	Counterbore Depth
	<i>A</i>	TPI	<i>B</i>	<i>D</i>	<i>J</i>	<i>K</i>	<i>L</i>	<i>M</i>
Tolerance>		(Ref.)	± 0.25	± 0.8	NA	± 0.8	± 0.4	± 0.4
1 ¹³ / ₁₆	1 ³ / ₄	6	40.64	95.3	126	38.1	NA	NA
2 ¹ / ₁₆	2	6	46.99	95.3	130	44.5	NA	NA
2 ⁹ / ₁₆	2 ¹ / ₂	6	59.66	106.4	138	59.2	23.8	15.9
3 ¹ / ₁₆	3	6	72.36	106.4	146	72.1	28.6	15.9

Nominal Outlet Size in.	Nominal Thread Size in.	Threads per Inch	Stub Acme Class 2G Thread Form Dimensions			
			Thread Major Diameter	Thread Pitch Diameter	Thread Minor Diameter	Width of Thread at Root
	<i>A</i>	TPI	<i>E</i>	<i>F</i>	<i>G</i>	<i>H</i>
Tolerance>			± 0.10	± 0.3	± 0.3	(Ref.)
1 ¹³ / ₁₆	1 ³ / ₄	6	44.35	42.6	41.1	1.73
2 ¹ / ₁₆	2	6	50.70	49.0	47.5	1.73
2 ⁹ / ₁₆	2 ¹ / ₂	6	63.40	61.6	60.2	1.73
3 ¹ / ₁₆	3	6	76.10	74.3	72.9	1.73

Table D.21—HPVR Preparation Dimensions, 103.5 MPa and 138.0 MPa

Dimensions in millimeters unless noted otherwise; surface roughness in micrometers

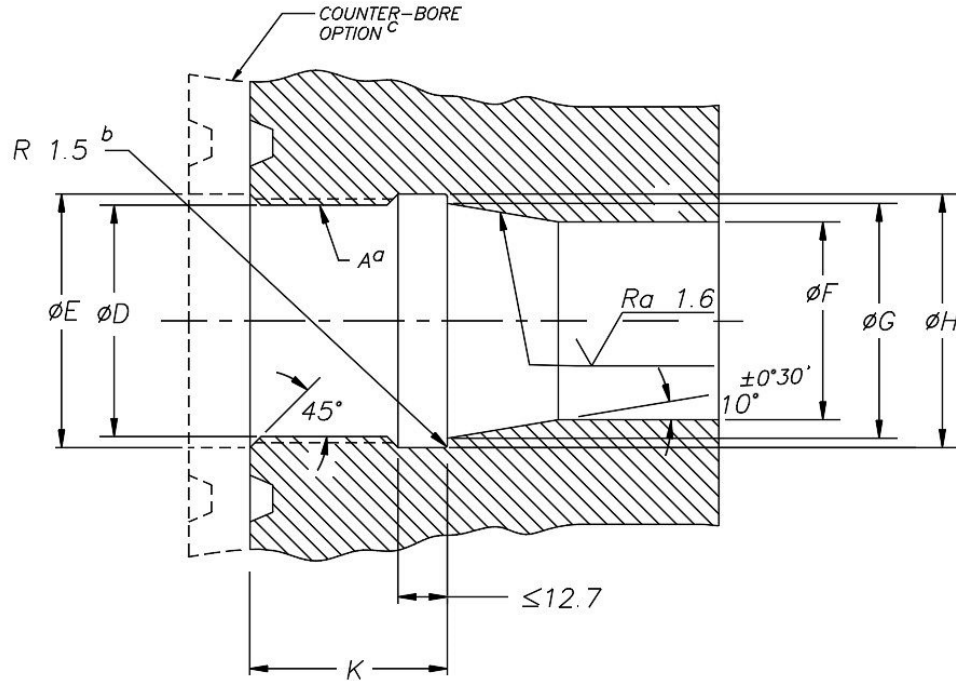

FOOTNOTES

- a Thread.
- b Typical two places.
- c Optional counterbore (12.7 mm deep max.).

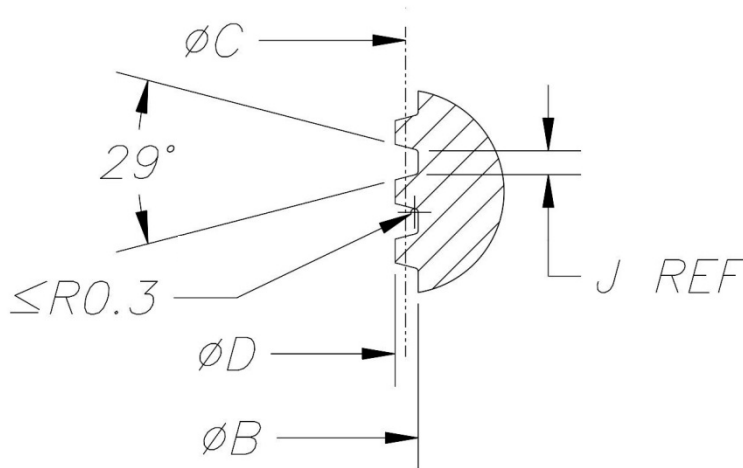

Thread Form Detail

- NOTE 1 Features and dimensions are typical for all full threads.
- NOTE 2 Tolerances on angles, unless otherwise noted, are ± 0.5 degrees.
- NOTE 3 All diameters are to be concentric within 0.13 mm (0.005 in.) total indicator reading.

Table D.21—HPVR Preparation Dimensions, 103.5 MPa and 138.0 MPa (continued)

Dimensions in millimeters unless noted otherwise

Nominal Outlet Size	Chamfer and Counterbore Diameter	Straight Through Bore	Large Diameter of Taper	Thread Relief Diameter	Depth to Taper
in.	<i>E</i>	<i>F</i>	<i>G</i>	<i>H</i>	<i>K</i>
Tolerance>	± 0.4	± 0.12	± 0.12	± 0.4	± 0.4
1 13/16	46.4	37.47	41.28	46.2	39.70
2 1/16	52.7	43.82	47.63	53.0	39.70
2 9/16	66.7	56.49	60.33	65.7	53.14
3 1/16	78.1	69.22	73.03	78.2	53.14

Nominal Outlet Size	Nominal Thread Size	Threads per Inch	Stub Acme Class 2G Thread Form Dimensions			
			Thread Major Diameter	Thread Pitch Diameter	Thread Minor Diameter	Width of Thread at Root
in.	in.		<i>B</i>	<i>C</i>	<i>D</i>	<i>J</i>
	<i>A</i>	TPI				
Tolerance>			± 0.25	± 0.25	± 0.10	(Ref.)
1 13/16	1 3/4	6	45.21	43.43	42.01	1.65
2 1/16	2	6	51.56	49.78	48.36	1.65
2 9/16	2 1/2	6	64.29	62.51	61.06	1.65
3 1/16	3	6	76.99	75.21	73.76	1.65

Table D.22—Flanged Full-bore Gate Valves

Dimensions in millimeters unless noted otherwise

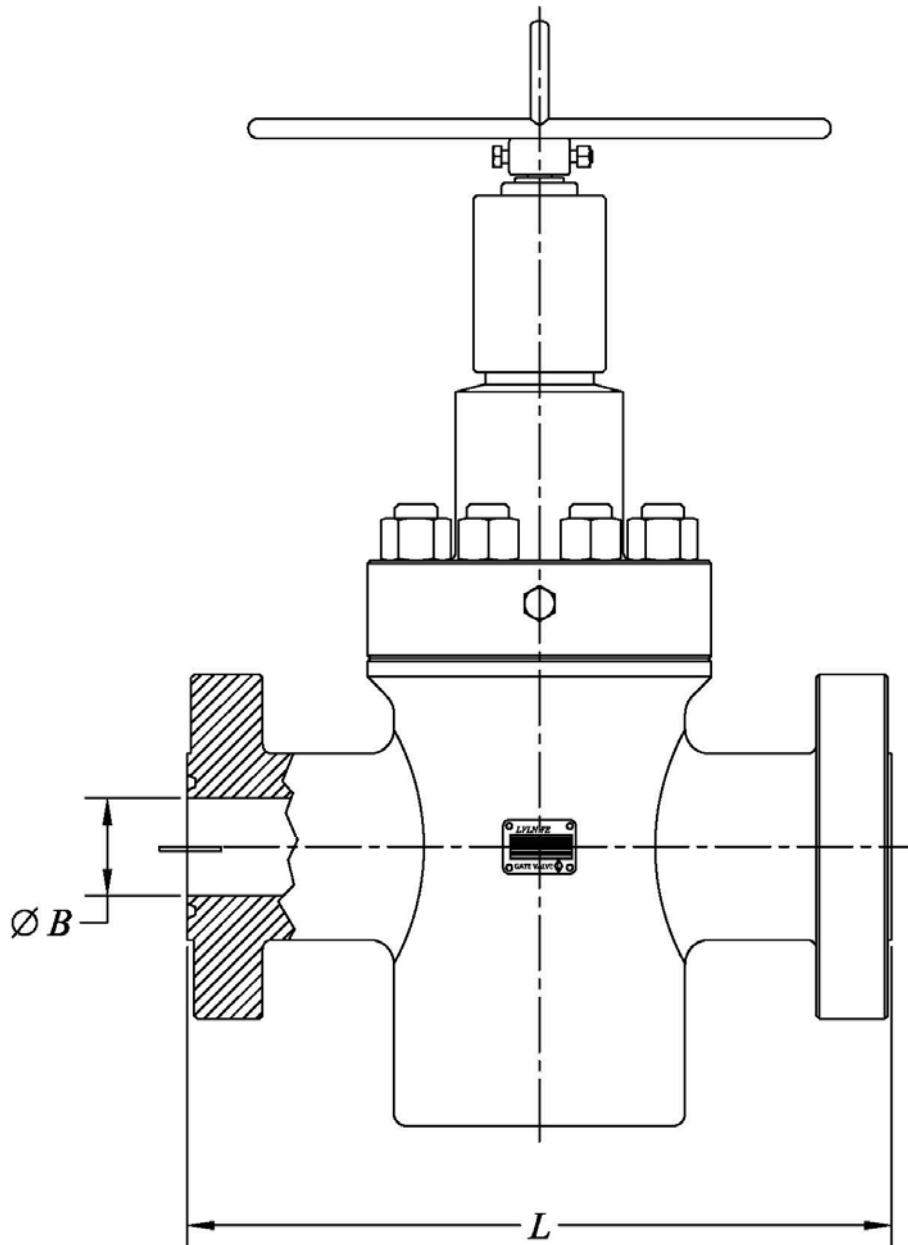

Table D.22—Flanged Full-bore Gate Valves (continued)

Dimensions in millimeters unless noted otherwise

Nominal size in.	Bore	<i>L</i> , Face-to-face Length, millimeters					
	<i>B</i>	13.8 MPa	20.7 MPa	34.5 MPa	69.0 MPa	103.5 MPa	138.0 MPa
Tolerance>	+ 0.8/-0	± 2	± 2	± 2	± 2	± 2	± 2
1 ¹³ / ₁₆	46.0	—	—	—	464	457	533
2 ¹ / ₁₆ X 1 ¹³ / ₁₆	46.0	295	371	371	—	—	—
2 ¹ / ₁₆	52.3	295	371	371	521	483	584
2 ⁹ / ₁₆	65.0	333	422	422	565	533	673
3 ¹ / ₁₆	77.7	—	—	—	619	598	775
3 ¹ / ₈	79.3	359	435	473	—	—	—
3 ¹ / ₈ X 3 ³ / ₁₆	81.0	359	435	473	—	—	—
4 ¹ / ₁₆	103.1	435	511	549	670	737	965
4 ¹ / ₁₆ X 4 ¹ / ₈	104.7	435	511	549	—	—	—
4 ¹ / ₁₆ X 4 ¹ / ₄	108.0	435	511	549	—	—	—
5 ¹ / ₈ ^a	130.1 ^a	562	613	727	737	889	—
7 ¹ / ₁₆ X 5 ¹ / ₈	130.1 ^a	—	—	737	—	—	—
7 ¹ / ₁₆ X 6	152.4	562	613	737	—	—	—
7 ¹ / ₁₆ X 6 ¹ / ₈	155.5	—	—	737	—	—	—
7 ¹ / ₁₆ X 6 ³ / ₈	162.1	562	613	737	889	1041	PMR
7 ¹ / ₁₆ X 6 ⁵ / ₈	168.2	562	613	737	—	—	—
7 ¹ / ₁₆	179.3	664	714	813	889	1041	PMR
7 ¹ / ₁₆ X 7 ¹ / ₈	180.9	664	714	813	—	—	—
9	228.6	—	—	1041	PMR	—	—
11	279.4	—	—	PMR	—	—	—

FOOTNOTE
^a Bore tolerance for 5¹/₈ in. size is +1.0/-0.

Table D.23—Flanged Plug and Ball Valves

Dimensions in millimeters unless noted otherwise

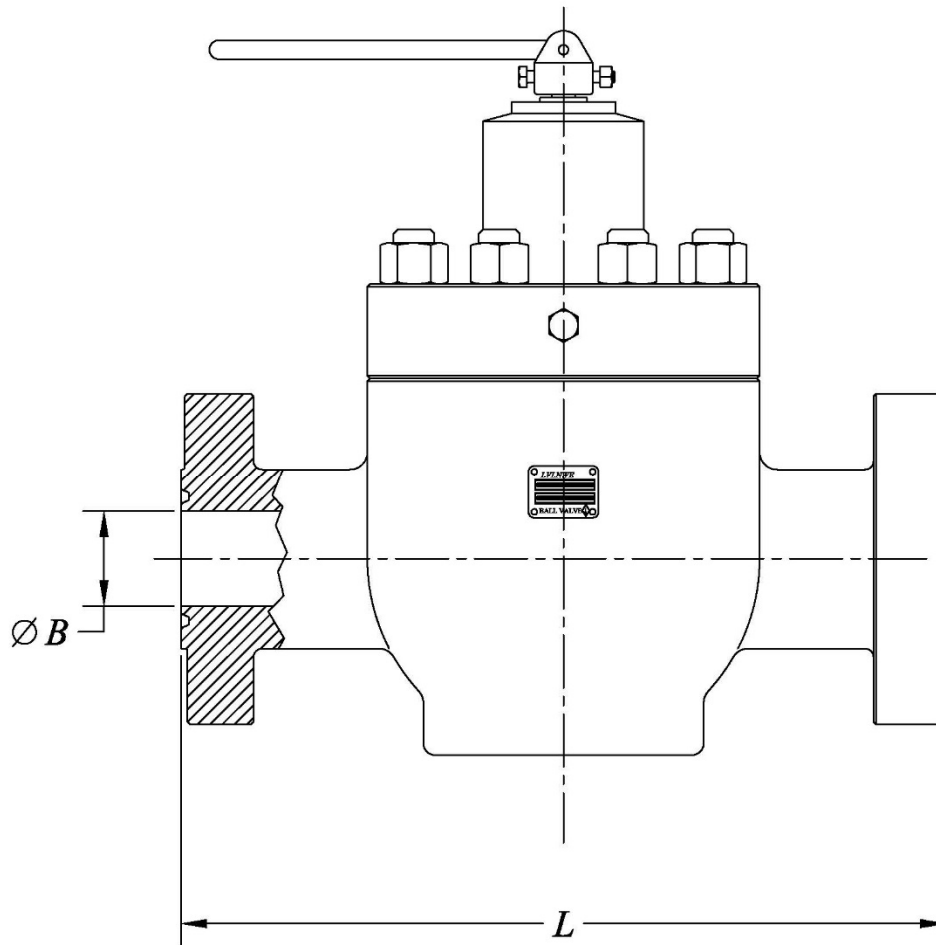

Table D.23—Flanged Plug and Ball Valves (continued)

Dimensions in millimeters unless noted otherwise

a) Flanged Full-bore Plug Valves							
Nominal Size in.	Bore	L, Face-to-face Length					
	B	13.8 MPa	20.7 MPa	34.5 MPa	69.0 MPa	103.5 MPa	138.0 MPa
Tolerance>	+0.8/-0	± 2	± 2	± 2	± 2	± 2	± 2
1 ¹³ / ₁₆	46.0	—	—	—	464	457	533
2 ¹ / ₁₆	52.3	333	384	394	521	483	584
2 ⁹ / ₁₆	65.0	384	435	457	565	533	673
3 ¹ / ₁₆	77.7	—	—	—	619	598	775
3 ¹ / ₈	79.3	448	473	527	—	—	—
3 ¹ / ₈ x 3 ³ / ₁₆	81.0	448	473	527	—	—	—
4 ¹ / ₁₆	103.1	511	562	629	670	737	—
4 ¹ / ₁₆ x 4 ¹ / ₈	104.7	511	562	629	—	—	—
4 ¹ / ₁₆ x 4 ¹ / ₄	108.0	511	562	629	—	—	—
5 ¹ / ₈	130.1 ^b	638	664	—	737	889	—
7 ¹ / ₁₆ x 6	152.4	727	765	—	—	—	—
7 ¹ / ₁₆ x 6 ³ / ₈	162.1	—	—	—	889	1041	PMR
7 ¹ / ₁₆	179.3	740	803	978	889	1041	PMR
7 ¹ / ₁₆ x 7 ¹ / ₈	180.9	740	803	978	—	—	—
9	228.6	—	—	—	PMR	1041	—
b) Flanged Full-bore and Reduced-opening Ball Valves							
Nominal Size in.	Bore	L, Face-to-face Length					
	B	13.8 MPa	20.7 MPa	34.5 MPa	69.0 MPa	103.5 MPa ^a	138.0 MPa ^a
Tolerance>	+0.8/-0	± 2	± 2	± 2	± 2	± 2	± 2
1 ¹³ / ₁₆	46.0	—	—	—	464	457	533
2 ¹ / ₁₆	52.3	295	371	371	521	483	584
2 ⁹ / ₁₆	65.0	333	422	473	565	533	673
3 ¹ / ₁₆	77.7	—	—	—	619	598	775
3 ¹ / ₈	79.3	359	384	473	—	—	—
4 ¹ / ₁₆	103.1	435	460	549	670	737	—
5 ¹ / ₈	130.1 ^b	—	—	—	737	889	—
7 ¹ / ₁₆ x 6	152.4	562	613	711	—	—	—
7 ¹ / ₁₆ x 6 ³ / ₈	162.1	—	—	—	889	1041	—
7 ¹ / ₁₆	179.3	—	—	—	889	1041	PMR
9	228.6	—	—	—	PMR	—	—
FOOTNOTE							
^a Applies to full bore only.							
^b Bore tolerance for 5 ¹ / ₈ in. size is +1.0/-0.							

Table D.24—Flanged Swing and Lift Check Valves

Dimensions in millimeters unless noted otherwise

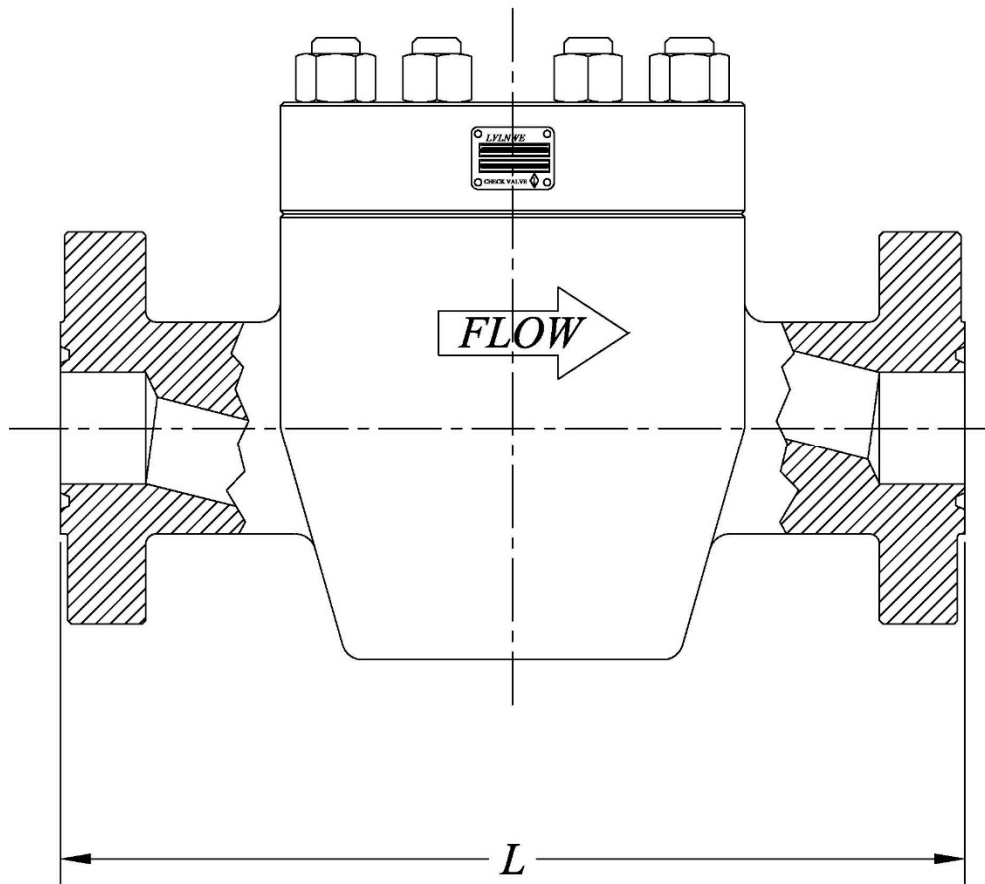

a) Minimum Bore Sizes for Full-opening Check Valves, 13.8 MPa, 20.7 MPa, and 34.5 MPa			
Nominal Size in.	Minimum Bore Size		
	13.8 MPa	20.7 MPa	34.5 MPa
Tolerance>	+1.6/-0	+1.6/-0	+1.6/-0
2 ¹ / ₁₆	52.5	49.3	42.9
2 ⁹ / ₁₆	62.7	59.0	54.0
3 ¹ / ₈	77.9	73.7	66.6
4 ¹ / ₁₆	102.3	97.2	87.3
7 ¹ / ₁₆	146.3	146.3	131.8
9	198.5	189.0	173.1
11	247.7	236.6	215.9

Table D.24—Flanged Swing and Lift Check Valves (continued)

b) Regular and Full-opening Flanged Swing and Lift Check Valves, 13.8 MPa, 20.7 MPa, and 34.5 MPa RWP					
Nominal Size in.	L, Short Pattern Face-to-face Length, mm			L, Long Pattern Face-to-face Length, mm	
	13.8 MPa	20.7 MPa	34.5 MPa	20.7 MPa	34.5 MPa
Tolerance>	± 2	± 2	± 2	± 2	± 2
2 ¹ / ₁₆	295	371	371	—	—
2 ⁹ / ₁₆	333	422	422	—	—
3 ¹ / ₈	359	384	473	435	—
4 ¹ / ₁₆	435	460	549	511	—
7 ¹ / ₁₆	562	613	711	—	737
9	664	740	841	—	—
11	790	841	1000	—	—

c) Regular and Full-opening Flanged Swing and Lift Check Valves, 69.0 MPa, 103.5 MPa, and 138.0 MPa RWP			
Nominal Size in.	L, Face-to-face Length, in.		
	69.0 MPa	103.5 MPa	138.0 MPa
Tolerance>	± 2	± 2	± 2
1 ¹³ / ₁₆	464	457	533
2 ¹ / ₁₆	521	483	584
2 ⁹ / ₁₆	565	533	673
3 ¹ / ₁₆	619	598	775
4 ¹ / ₁₆	670	737	—
5 ¹ / ₈	737	—	—
7 ¹ / ₁₆	889	—	—

**Table D.25—Center Spacing of Conduit Bores for Dual Parallel Bore Valves
for 13.8 MPa, 20.7 MPa, 34.5 MPa, and 69.0 MPa**

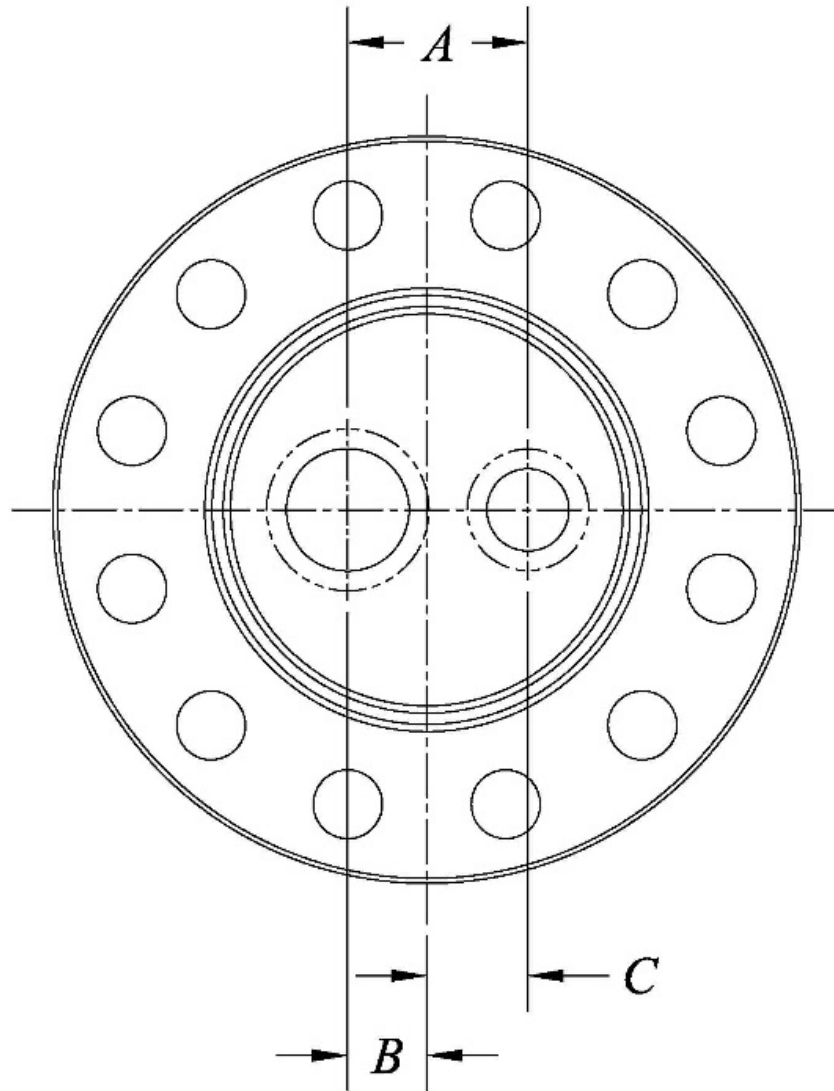

**Table D.25—Center Spacing of Conduit Bores for Dual Parallel Bore Valves
for 13.8 MPa, 20.7 MPa, 34.5 MPa, and 69.0 MPa (continued)**

Dimensions in millimeters unless noted otherwise

Maximum Nominal Valve Size in.	Bore Center to Bore Center	Large-bore to End- connector Center	Small-bore to End-Connector Center	Minimum End- connector Size	Basic Casing Size	
					OD	Lineic Mass kg/m
13.8 MPa, 20.7 MPa, and 34.5 MPa RWP						
1 ¹³ / ₁₆	70.64	35.32	35.32	7 ¹ / ₁₆	139.7	25
2 ¹ / ₁₆	90.09	45.05	45.05	7 ¹ / ₁₆	177.8	57
2 ⁹ / ₁₆ X 2 ¹ / ₁₆	90.09	41.91	48.18	7 ¹ / ₁₆	177.8	43
2 ⁹ / ₁₆ X 2 ¹ / ₁₆	101.60	47.63	53.98	9	193.7	58
2 ⁹ / ₁₆	101.60	50.80	50.80	9	193.7	44
2 ⁹ / ₁₆	114.30	57.15	57.15	9	219.1	73
3 ¹ / ₈ X 2 ¹ / ₁₆	116.28	51.00	65.28	9	219.1	73
3 ¹ / ₈ X 2 ⁹ / ₁₆	128.19	64.10	64.10	11	244.5	80
3 ¹ / ₈	128.19	64.10	64.10	11	244.5	80
69.0 MPa RWP						
1 ¹³ / ₁₆	70.64	35.32	35.32	7 ¹ / ₁₆	139.7	25
2 ¹ / ₁₆	90.09	45.05	45.05	7 ¹ / ₁₆	177.8	57
2 ⁹ / ₁₆ X 2 ¹ / ₁₆	90.09	41.91	48.18	7 ¹ / ₁₆	177.8	43
2 ⁹ / ₁₆ X 2 ¹ / ₁₆	101.60	47.63	53.98	9	193.7	58
2 ⁹ / ₁₆	101.60	50.80	50.80	9	193.7	44
2 ⁹ / ₁₆	114.30	57.15	57.15	9	219.1	73
3 ¹ / ₁₆	128.19	64.10	64.10	11	244.5	80
FOOTNOTE						
Nominal sizes for valves and end connectors are in inches.						

Table D.26—Center Spacing of Conduit Bores for Triple, Quadruple, and Quintuple Parallel Bore Valves for 13.8 MPa, 20.7 MPa, 34.5 MPa, and 69.0 MPa

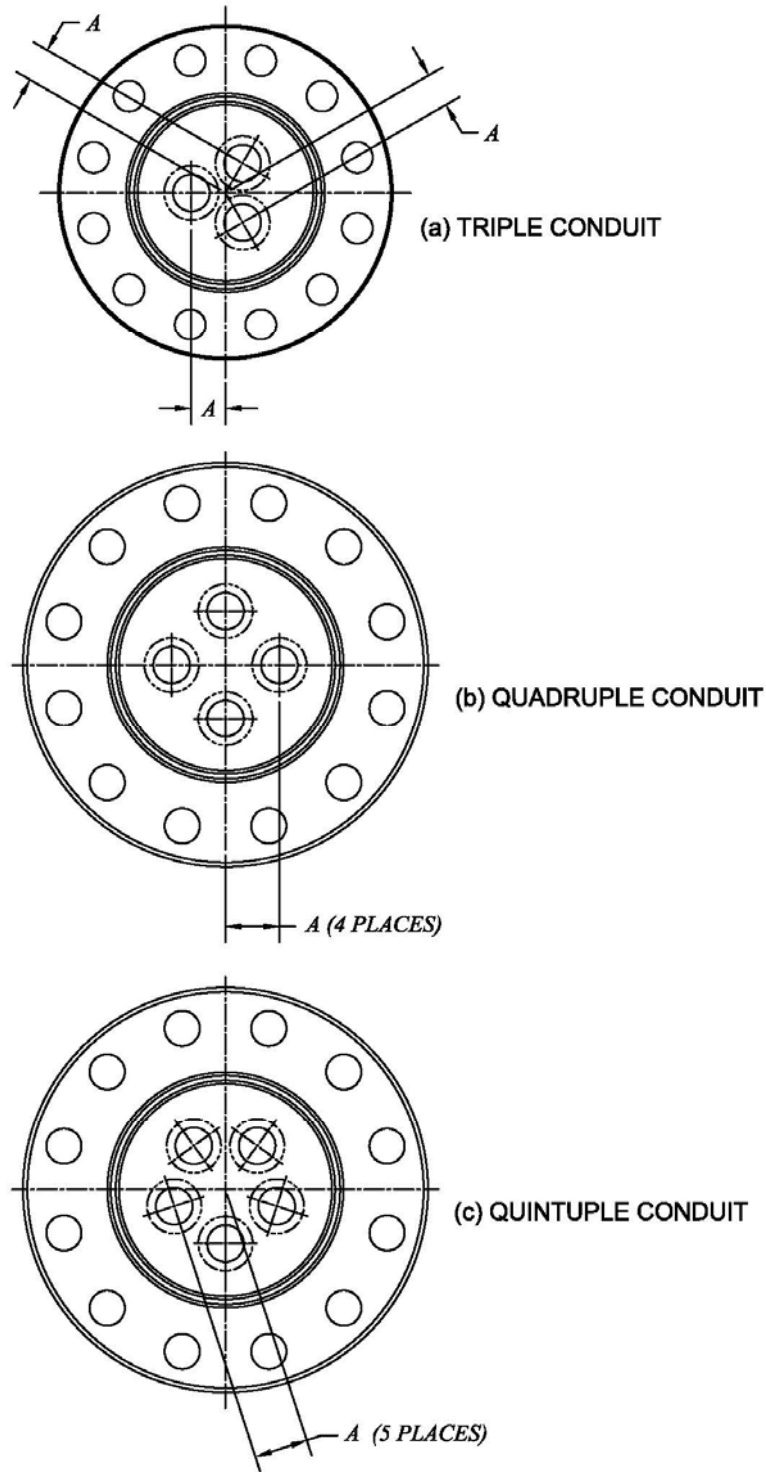

Table D.26—Center Spacing of Conduit Bores for Triple, Quadruple, and Quintuple Parallel Bore Valves for 13.8 MPa, 20.7 MPa, 34.5 MPa, and 69.0 MPa (continued)

Dimensions in millimeters unless noted otherwise

Maximum Valve Size in.	Flange Center to Bore Center <i>A</i>	Minimum End-connector Size in.	Basic Casing Size	
			<i>OD</i>	Lineic Mass kg/m
13.8 MPa; 20.7 MPa and 34.5 MPa RWP				
Triple-conduit Valve				
1 ¹³ / ₁₆	47.63	7 ¹ / ₁₆	168.3	35.7
2 ¹ / ₁₆	49.21	9	177.8	38.7
2 ¹ / ₁₆	53.98	9	193.7	58.0
2 ⁹ / ₁₆	71.44	11	244.5	79.6
Quadruple-conduit Valve				
1 ¹³ / ₁₆	73.03	11	219.1	53.6
1 ¹³ / ₁₆	77.79	11	244.5	All
2 ¹ / ₁₆	77.79	11	244.5	79.6
2 ⁹ / ₁₆	87.31	11	273.1	82.6
2 ⁹ / ₁₆	101.60	13 ⁵ / ₈	298.5	80.4
Quintuple-conduit Valve				
2 ¹ / ₁₆	77.79	11	244.5	79.6
69.0 MPa RWP				
Triple-conduit Valve				
1 ¹³ / ₁₆	47.63	7 ¹ / ₁₆	168.3	35.7
2 ¹ / ₁₆	49.21	9	177.8	38.7
2 ¹ / ₁₆	53.98	9	193.7	58.0
2 ⁹ / ₁₆	71.44	11	244.5	79.6
Quadruple-conduit Valve				
2 ⁹ / ₁₆	87.31	11	273.1	82.6
FOOTNOTE				
Nominal sizes for valves and end connectors are in inches.				

Table D.27—Maximum Hanger Outside Diameter for Wellheads

Dimensions in millimeters unless noted otherwise

Nominal Size ^a and Minimum Through-bore of Drill-through Equipment	Rated Working Pressure	Maximum Outside Diameter of Hanger
in.	MPa	mm
7 ¹ / ₁₆	13.8, 20.7, and 34.5	178.05
7 ¹ / ₁₆	69.0, 103.5, and 138.0	178.05
9	13.8, 20.7, and 34.5	226.90
9	69.0 and 103.5	226.90
11	13.8, 20.7, and 34.5	277.32
11	69.0 and 103.5	277.32
13 ⁵ / ₈	13.8 and 20.7	343.48
13 ⁵ / ₈	34.5 and 69.0	343.48
16 ³ / ₄	13.8 and 20.7	422.28
16 ³ / ₄	34.5 and 69.0	422.28
18 ³ / ₄	34.5 and 69.0	473.08
21 ¹ / ₄	13.8	536.58
20 ³ / ₄	20.7	523.88
21 ¹ / ₄	34.5 and 69.0	536.58

FOOTNOTE

^a Nominal size of upper end connector of wellhead body in which the hanger is used.

Table D.28—Minimum Vertical Full-opening Wellhead Body Bores and Maximum Casing Sizes

Dimensions in millimeters unless noted otherwise

Nominal Connector ^a		Casing Beneath Body			Minimum Vertical Full-opening Wellhead Body Bore mm
Nominal Size of Connector in.	Rated Working Pressure MPa	Label ^b <i>OD</i>	Nominal Lineic Mass ^b kg/m	Specified Drift Diameter mm	
7 ¹ / ₁₆	13.8	7	25.30	162.89	163.8
7 ¹ / ₁₆	20.7	7	29.76	160.81	161.5
7 ¹ / ₁₆	34.5	7	34.23	158.52	159.5
7 ¹ / ₁₆	69.0	7	43.16	153.90	154.7
7 ¹ / ₁₆	103.5	7	56.55	147.19	148.1
7 ¹ / ₁₆	138.0	7	56.55	147.19	148.1
9	13.8	8 ⁵ / ₈	35.72	202.49	203.2
9	20.7	8 ⁵ / ₈	47.62	198.02	198.9
9	34.5	8 ⁵ / ₈	53.57	195.58	196.3
9	69.0	8 ⁵ / ₈	59.53	193.04	193.5
9	103.5	8 ⁵ / ₈	72.92	187.60	188.2
11	13.8	10 ³ / ₄	60.27	251.31	252.0
11	20.7	10 ³ / ₄	60.27	251.31	252.0
11	34.5	10 ³ / ₄	75.90	246.23	247.1
11	69.0	9 ⁵ / ₈	79.62	212.83	213.6
11	103.5	9 ⁵ / ₈	79.62	212.83	213.6
13 ⁵ / ₈	13.8	13 ³ / ₈	81.10	316.46	317.5
13 ⁵ / ₈	20.7	13 ³ / ₈	90.78	313.92	314.7
13 ⁵ / ₈	34.5	13 ³ / ₈	107.15	309.65	310.4
13 ⁵ / ₈	69.0	11 ³ / ₄	89.29	269.65	270.8
16 ³ / ₄	13.8	16	96.73	382.58	383.3
16 ³ / ₄	20.7	16	125.01	376.48	377.4
16 ³ / ₄	34.5	16	125.01	376.48	377.4
16 ³ / ₄	69.0	16	125.01	376.48	377.4
18 ³ / ₄	34.5	18 ⁵ / ₈	130.21	446.20	446.8
18 ³ / ₄	69.0	18 ⁵ / ₈	130.21	446.20	446.8
20 ³ / ₄	20.7	20	139.89	480.97	481.8
21 ¹ / ₄	13.8	20	139.89	480.97	481.8
21 ¹ / ₄	34.5	20	139.89	480.97	481.8
21 ¹ / ₄	69.0	20	139.89	480.97	481.8

FOOTNOTES

^a Upper end connectors of wellhead body.

^b Maximum size and minimum mass of casing on which bore is based.

Table D.29—Pipe Thread Counterbore and Standoff Dimensions

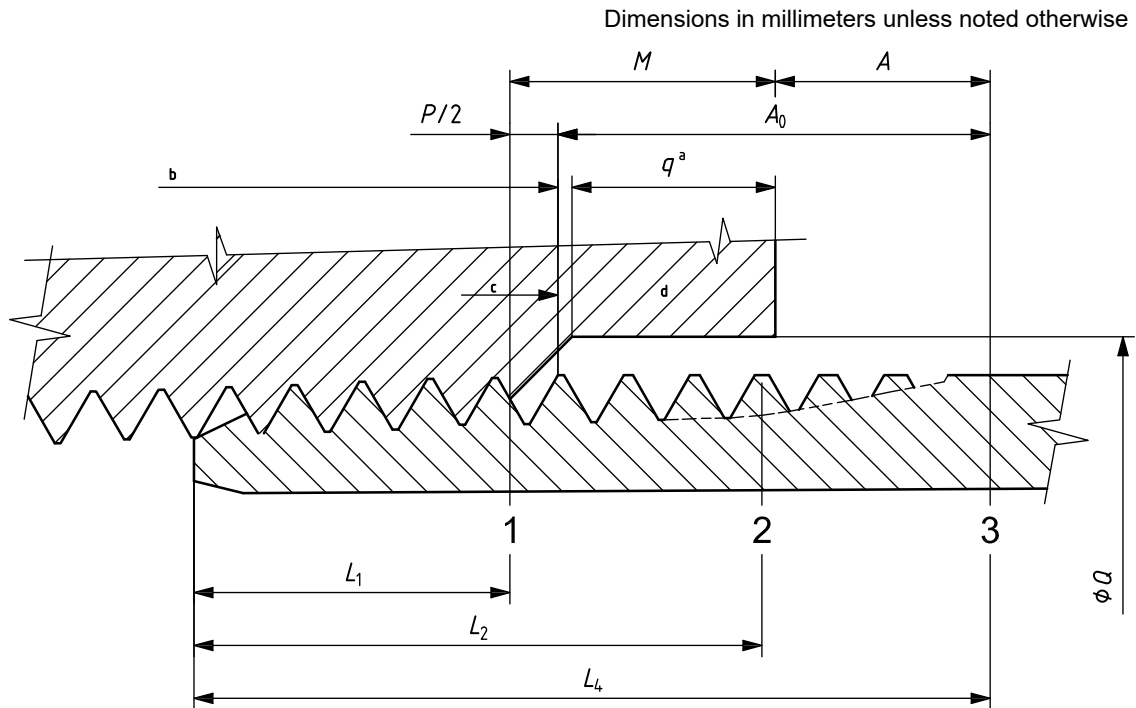
**Key**

- 1 plane of hand-tight engagement
- 2 plane of effective thread length
- 3 plane of vanish point
- a See 14.3.2.3.
- b Internal thread length.
- c Without counterbore.
- d With counterbore.

NOTE See API 5B for dimensions L_1 , L_2 , and L_4 .

Table D.29—Pipe Thread Counterbore and Standoff Dimensions (continued)

Dimensions in millimeters unless noted otherwise

(1)	(2)	(3)	(4)	(5)	(6)	(7)
Nominal Thread Size	Length: Plane of Vanish Point to Hand-tight Plane	Hand-tight Standoff		Length: Face of Counterbore to Hand-tight Plane	Counterbore	
		Thread without Counterbore	Thread with Shallow Counterbore		Diameter	Depth
in.	$A + M$	A_0	A	M	Q	q
Line Pipe Threads						
1/8	5.40	4.93	1.01	4.38	11.9	3.3
1/4	10.02	9.32	5.45	4.57	15.2	3.3
3/8	9.16	8.45	4.55	4.61	18.8	3.3
1/2	11.72	10.82	3.45	8.28	23.6	6.4
3/4	11.54	10.64	3.27	8.27	29.0	6.4
1	14.85	13.74	6.32	8.53	35.8	6.4
1 1/4	14.95	13.84	6.48	8.47	44.5	6.4
1 1/2	15.37	14.27	6.89	8.48	50.5	6.4
2	15.80	14.70	6.87	8.94	63.5	6.4
2 1/2	22.59	21.00	10.04	12.55	76.2	9.7
3	22.04	20.45	9.45	12.59	92.2	9.7
3 1/2	21.91	20.33	9.32	12.59	104.9	9.7
4	22.60	21.01	9.99	12.61	117.6	9.7
5	22.94	21.35	10.35	12.58	144.5	9.7
6	25.10	23.51	12.48	12.62	171.5	9.7
8	27.51	25.93	14.81	12.70	222.3	9.7
10	29.18	27.59	16.36	12.81	276.4	9.7
12	30.45	28.86	16.83	13.62	328.7	9.7
14D	28.49	26.90	14.94	13.56	360.4	9.7
16D	27.22	25.63	13.71	13.52	411.2	9.7
18D	27.53	25.94	14.00	13.53	462.0	9.7
20D	29.43	27.84	15.85	13.58	512.8	9.7

Table D.30—Gauging of Casing and Tubing Threads

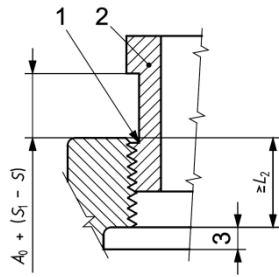

a) Internal recess without counterbore

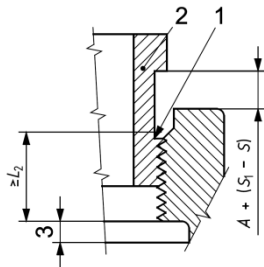

b) Internal recess with shallow counterbore

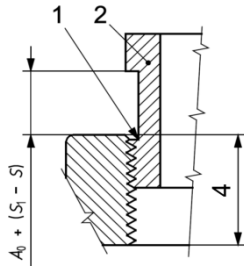

c) Thread clearance without counterbore

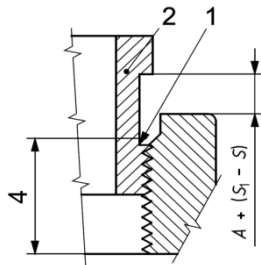

d) Thread clearance with shallow counterbore

Key

- 1 gauge notch, alignment—chamfer bottom, within tolerance
- 2 working plug gauge
- 3 recess clearance
- 4 L_2 (min.) plus thread clearance

Application of Working Plug Gauge

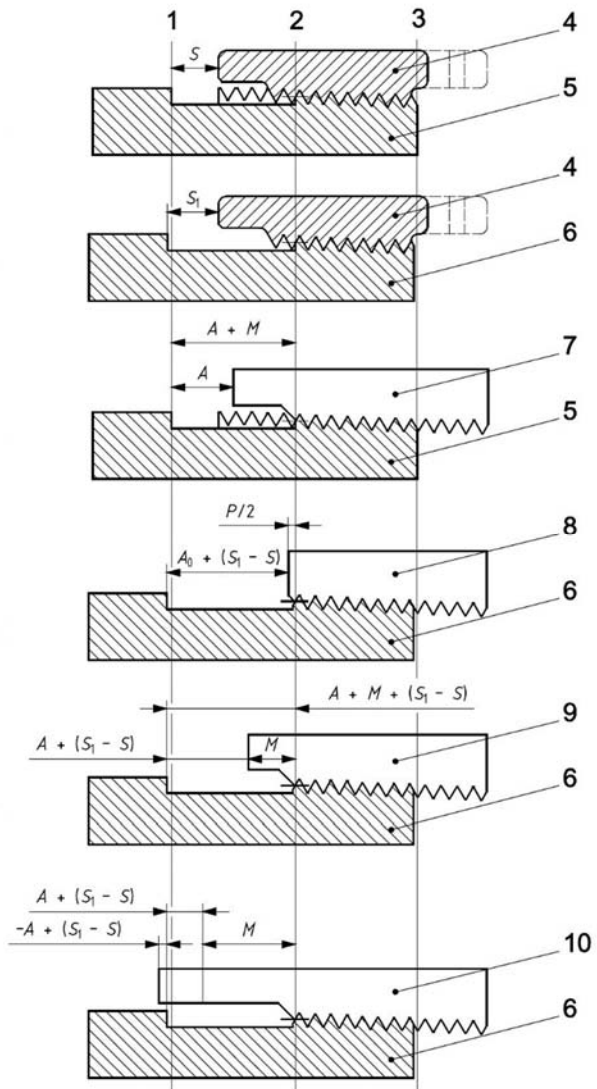

Key

- 1 plane of vanish point
- 2 plane of hand-tight engagement
- 3 plane of end of pipe
- 4 master ring gauge
- 5 master plug gauge
- 6 working plug gauge
- 7 product thread
- 8 product thread without counterbore
- 9 product thread with shallow counterbore
- 10 product thread with deep counterbore

NOTE See API 5B for dimensions of S and S_1 .

Gauging Line Pipe, Casing and Tubing Internal Threads, Hand-tight Assembly

Table D.30—Gauging of Casing and Tubing Threads (continued)

(1)	(2)	(3)	(4)	(5)	(6)	(7)
Nominal Thread Size	Length: Plane of Vanish Point to Hand-tight Plane	Hand-tight Standoff		Length: Face of Counterbore to Hand-tight Plane	Counterbore	
		Thread without Counterbore	Thread with Shallow Counterbore		Diameter	Depth
in.	$A + M$	A_0	A	M	Q	q
Long and Short Casing Threads Dimensions in millimeters except nominal size						
4 ¹ / ₂	27.41	25.82	15.00	12.40	117.6	9.7
5	27.41	25.82	15.00	12.40	130.3	9.7
5 ¹ / ₂	27.41	25.82	15.00	12.40	143.0	9.7
6 ⁵ / ₈	27.41	25.82	15.07	12.34	171.5	9.7
7	27.41	25.82	15.00	12.40	181.1	9.7
7 ⁵ / ₈	29.11	27.52	16.72	12.39	196.9	9.7
8 ⁵ / ₈	29.11	27.52	16.72	12.39	222.3	9.7
9 ⁵ / ₈	29.11	27.52	16.72	12.39	247.7	9.7
10 ³ / ₄ ^a	29.11	27.52	16.65	12.46	276.4	9.7
11 ³ / ₄ ^a	29.11	27.52	16.65	12.46	301.8	9.7
13 ³ / ₈ ^a	29.11	27.52	15.95	13.15	344.4	9.7
16 ^a	29.11	27.52	15.89	13.22	411.2	9.7
20 ^a	29.11	27.52	15.89	13.22	512.8	9.7
Nonupset Tubing Threads Dimensions in millimeters except nominal size						
1.050	16.41	15.14	8.13	8.28	29.0	6.4
1.315	16.41	15.14	8.07	8.34	35.8	6.4
1.660	16.41	15.14	8.13	8.28	44.5	6.4
1.900	16.41	15.14	8.13	8.28	50.5	6.4
2 ³ / ₈	16.41	15.14	7.69	8.72	63.5	6.4
2 ⁷ / ₈	16.41	15.14	4.51	11.90	76.2	9.7
3 ¹ / ₂	16.41	15.14	4.45	11.96	92.2	9.7
4	19.91	18.33	7.65	12.27	104.9	9.7
4 ¹ / ₂	19.91	18.33	7.65	12.27	117.6	9.7
External Upset Tubing Threads Dimensions in millimeters except nominal size						
1.050	16.41	15.14	8.07	8.34	35.8	6.4
1.315	16.41	15.14	7.99	8.42	39.9	6.4
1.660	16.41	15.14	8.04	8.37	48.5	6.4
1.900	16.41	15.14	8.05	8.36	55.6	6.4
2 ³ / ₈	19.91	18.33	10.87	9.04	69.1	6.4
2 ⁷ / ₈	19.91	18.33	7.69	12.22	81.8	9.7
3 ¹ / ₂	19.91	18.33	7.65	12.27	98.6	9.7
4	19.91	18.33	7.65	12.27	111.3	9.7
4 ¹ / ₂	19.91	18.33	7.65	12.27	124.0	9.7
FOOTNOTE						
^a Short casing threads only (long casing threads not covered).						

Annex E (normative)

Dimensional Tables—USC Units

Table E.1—Type 6B Flanges for 2000 psi

Table E.2—Type 6B Flanges for 3000 psi

Table E.3—Type 6B Flanges for 5000 psi

Table E.4—Type 6BX Flanges for 10,000 psi

Table E.5—Type 6BX Flanges for 15,000 psi

Table E.6—Type 6BX Flanges for 20,000 psi

Table E.7—Type 6BX Large-bore Flanges for 2000 psi, 3000 psi, and 5000 psi

Table E.8—Type R Ring Grooves

Table E.9—Type R Ring Gaskets

Table E.10—Type RX Ring Gaskets

Table E.11—Type BX Ring Grooves

Table E.12—Type BX Ring Gaskets

Table E.13—Flanged Crosses and Tees

Table E.14—Studded Crosses and Tees

Table E.15—Bullplugs

Table E.16—VR Plug Dimensions, 2000 psi, 3000 psi, 5000 psi, and 10,000 psi

Table E.17—VR Preparation Dimensions, 2000 psi, 3000 psi, 5000 psi, and 10,000 psi

Table E.18—VR Plug Thread Gauging Dimensions, 2000 psi, 3000 psi, 5000 psi, and 10,000 psi

Table E.19—VR Preparation Thread Gauging Dimensions, 2000 psi, 3000 psi, 5000 psi, and 10,000 psi

Table E.20—HPVR Plug Dimensions, 15,000 psi and 20,000 psi

Table E.21—HPVR Preparation Dimensions, 15,000 psi and 20,000 psi

Table E.22—Flanges Full-bore Gate Valves

Table E.23—Flanged Plug and Ball Valves

Table E.24—Flanged Swing and Lift Check Valves

Table E.25—Center Spacing of Conduit Bores for Dual Parallel Bore Valves, 2000 psi, 3000 psi, 5000 psi, and 10,000 psi

Table E.26—Center Spacing of Conduit Bores for Triple, Quadruple, and Quintuple Parallel Bore Valves, 2000 psi, 3000 psi, 5000 psi, and 10,000 psi

Table E.27—Maximum Hanger Outside Diameter for Wellheads

Table E.28—Minimum Vertical Full-opening Wellhead Body Bores and Maximum Casing Sizes

Table E.29—Pipe Thread Counterbore and Standoff Dimensions

Table E.30—Gauging of Casing and Tubing Threads

Table E.1—Type 6B Flanges for 2000 psi

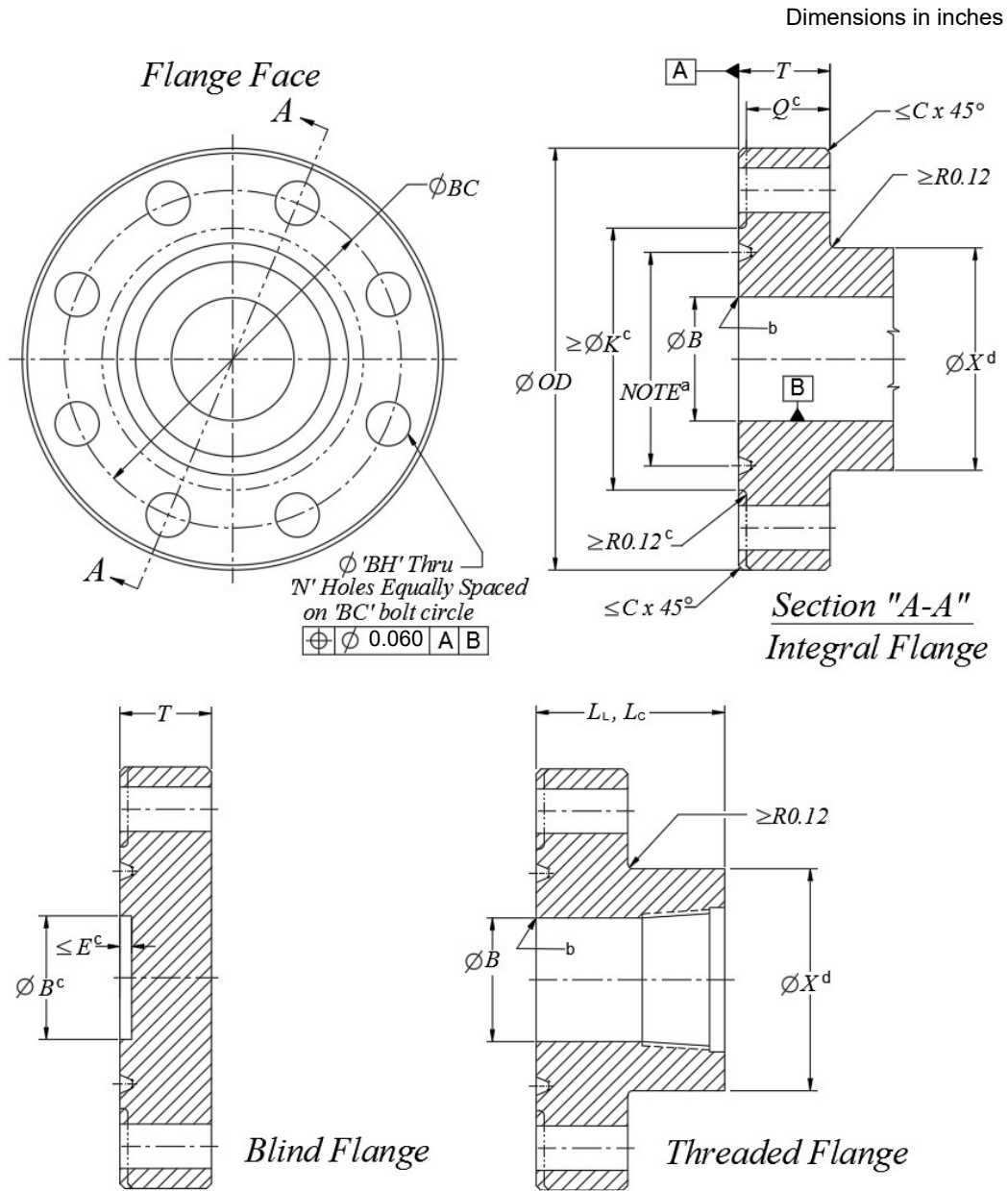

FOOTNOTES

- a Ring groove shall be concentric with bore B within 0.010 in. diametrical runout. See Table E.8 for ring groove dimensions.
- b Break sharp corner.
- c Raised face K and counterbore E are optional features.
- d Diameter X is a reference dimension.

Table E.1—Type 6B Flanges for 2000 psi (continued)

Dimensions in inches

Nominal Size of Flange ^a	Maximum Bore	Outside Diameter of Flange	Max. Chamfer	Diameter of Raised Face	Total Thickness of Flange	Basic Thickness of Flange	Diameter of Hub	Counter-bore Depth
	<i>B</i>	<i>OD</i>	<i>C</i>	<i>K</i>	<i>T</i>	<i>Q</i>	<i>X</i>	<i>E</i>
Tolerance	max.	As noted	max.	min.	+0.12/-0	min.	Reference	+0.02/-0
2 ¹ / ₁₆	2.09	6.50 ±0.06	0.12	4.25	1.31	1.00	3.31	0.31
2 ⁹ / ₁₆	2.59	7.50 ±0.06	0.12	5.00	1.44	1.12	3.94	0.31
3 ¹ / ₈	3.22	8.25 ±0.06	0.12	5.75	1.56	1.25	4.62	0.31
4 ¹ / ₁₆	4.28	10.75 ±0.06	0.12	6.88	1.81	1.50	6.00	0.31
5 ¹ / ₈	5.16	13.00 ±0.06	0.12	8.25	2.06	1.75	7.44	0.31
7 ¹ / ₁₆	7.16	14.00 ±0.12	0.25	9.50	2.19	1.88	8.75	0.31
9	9.03	16.50 ±0.12	0.25	11.88	2.50	2.19	10.75	0.31
11	11.03	20.00 ±0.12	0.25	14.00	2.81	2.50	13.50	0.31
13 ⁵ / ₈	13.66	22.00 ±0.12	0.25	16.25	2.94	2.62	15.75	0.31
16 ³ / ₄	16.78	27.00 ±0.12	0.25	20.00	3.31	3.00	19.50	0.31
21 ¹ / ₄	21.28	32.00 ±0.12	0.25	25.00	3.88	3.50	24.00	0.38

FOOTNOTE

^a For flange sizes 26³/₄ in. and 30 in., see Table E.7.

Nominal Size of Flange ^a	Diameter of Bolt Circle	Number of Bolts	Bolt Size and TPI	Bolt Holes		Hub Length, Threaded Flange		Ring Groove Number
						Line Pipe Flange	Casing Flange	
	<i>BC</i>	<i>N</i>		<i>BH</i>		<i>L_L</i>	<i>L_C</i>	
Tolerance >	See figure for GDT		(Ref.)	Diameter	Tolerance	min.	min.	
2 ¹ / ₁₆	5.00	8	5/8-11	0.75	+0.06/-0.02	1.75	—	R 23
2 ⁹ / ₁₆	5.88	8	3/4-10	0.88	+0.06/-0.02	1.94	—	R 26
3 ¹ / ₈	6.62	8	3/4-10	0.88	+0.06/-0.02	2.12	—	R 31
4 ¹ / ₁₆	8.50	8	7/8-9	1.00	+0.06/-0.02	2.44	3.50	R 37
5 ¹ / ₈	10.50	8	1-8	1.12	+0.06/-0.02	2.69	4.00	R 41
7 ¹ / ₁₆	11.50	12	1-8	1.12	+0.06/-0.02	2.94	4.50	R 45
9	13.75	12	1 ¹ / ₈ -8	1.25	+0.06/-0.02	3.31	5.00	R 49
11	17.00	16	1 ¹ / ₄ -8	1.38	+0.06/-0.02	3.69	5.25	R 53
13 ⁵ / ₈	19.25	20	1 ¹ / ₄ -8	1.38	+0.06/-0.02	3.94	3.94	R 57
16 ³ / ₄	23.75	20	1 ¹ / ₂ -8	1.62	+0.09/-0.02	4.50	4.50	R 65
21 ¹ / ₄	28.50	24	1 ⁵ / ₈ -8	1.75	+0.09/-0.02	5.38	5.38	R 73

FOOTNOTE

^a For flange sizes 26³/₄ in. and 30 in., see Table E.7.

Table E.2—Type 6B Flanges for 3000 psi

Dimensions in inches

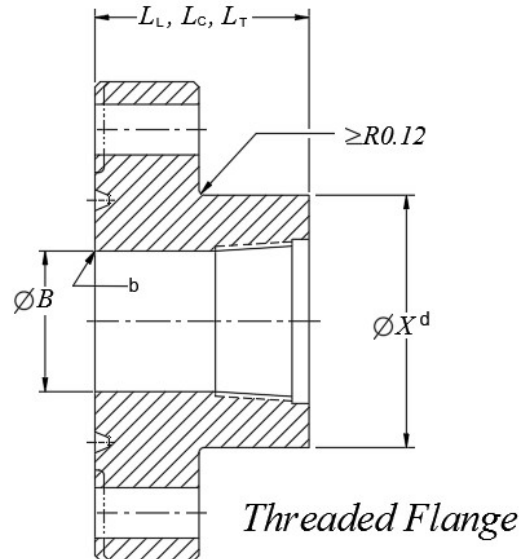
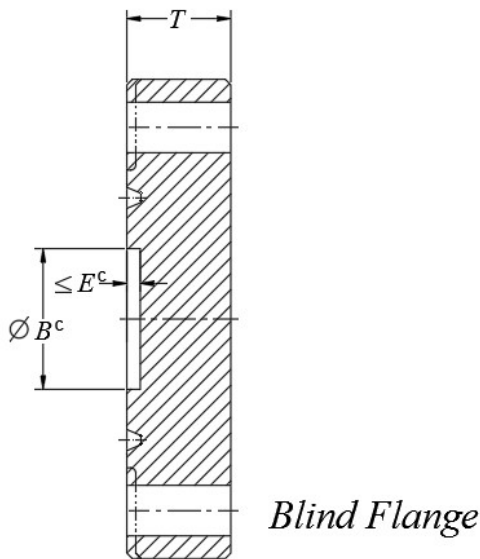
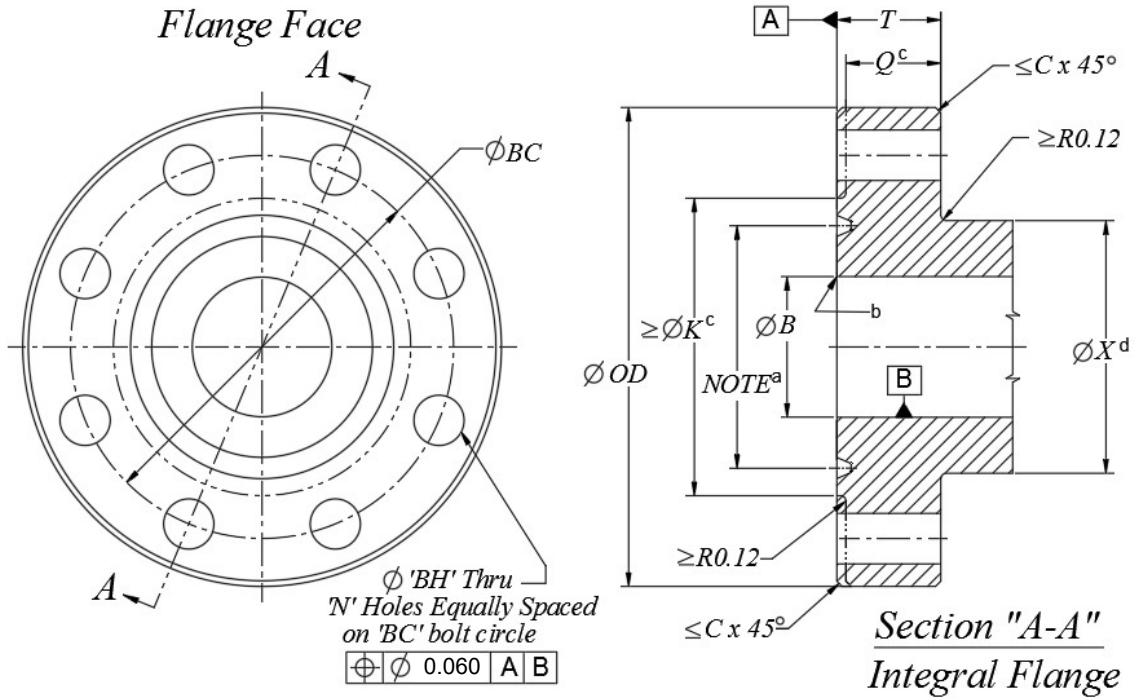

FOOTNOTES

- a Ring groove shall be concentric with bore B within 0.010 in. diametrical runout. See Table E.8 for ring groove dimensions.
- b Break sharp corner.
- c Raised face K and counterbore E are optional features.
- d Diameter X is a reference dimension.

Table E.2—Type 6B Flanges for 3000 psi (continued)

Dimensions in inches

Nominal Size of Flange ^a	Maximum Bore	Outside Diameter of Flange	Max. Chamfer	Diameter of Raised Face	Total Thickness of Flange	Basic Thickness of Flange	Diameter of Hub	Counter-bore Depth
	<i>B</i>	<i>OD</i>	<i>C</i>	<i>K</i>	<i>T</i>	<i>Q</i>	<i>X</i>	<i>E</i>
Tolerance	max.	As noted	max.	min.	+0.12/-0	min.	Reference	+0.02/-0
2 ¹ / ₁₆	2.09	8.50 ±0.06	0.12	4.88	1.81	1.50	4.12	0.31
2 ⁹ / ₁₆	2.59	9.62 ±0.06	0.12	5.38	1.94	1.62	4.88	0.31
3 ¹ / ₈	3.22	9.50 ±0.06	0.12	6.12	1.81	1.50	5.00	0.31
4 ¹ / ₁₆	4.28	11.50 ±0.06	0.12	7.12	2.06	1.75	6.25	0.31
5 ¹ / ₈	5.16	13.75 ±0.06	0.12	8.50	2.31	2.00	7.50	0.31
7 ¹ / ₁₆	7.16	15.00 ±0.12	0.25	9.50	2.50	2.19	9.25	0.31
9	9.03	18.50 ±0.12	0.25	12.12	2.81	2.50	11.75	0.31
11	11.03	21.50 ±0.12	0.25	14.25	3.06	2.75	14.50	0.31
13 ⁵ / ₈	13.66	24.00 ±0.12	0.25	16.50	3.44	3.12	16.50	0.31
16 ³ / ₄	16.78	27.75 ±0.12	0.25	20.62	3.94	3.50	20.00	0.44
20 ³ / ₄	20.78	33.75 ±0.12	0.25	25.50	4.75	4.25	24.50	0.50

FOOTNOTE

^a For flange sizes 26³/₄ in. and 30 in., see Table E.7.

Nominal Size of Flange ^a	Diameter of Bolt Circle	Number of Bolts	Bolt Size and TPI	Bolt Holes		Hub Length, Threaded Flange			Ring Groove
						Line Pipe Flange	Casing Flange	Tubing Flange	
	<i>BC</i>	<i>N</i>		<i>BH</i>		<i>L_L</i>	<i>L_C</i>	<i>L_T</i>	
Tolerance>	See figure for GDT		(Ref.)	Diameter	Tolerance	min.	min.	min.	
2 ¹ / ₁₆	6.50	8	7/8-9	1.00	+0.06/-0.02	2.56	—	2.56	R 24
2 ⁹ / ₁₆	7.50	8	1-8	1.12	+0.06/-0.02	2.81	—	2.81	R 27
3 ¹ / ₈	7.50	8	7/8-9	1.00	+0.06/-0.02	2.44	—	2.94	R 31
4 ¹ / ₁₆	9.25	8	1 ¹ / ₈ -8	1.25	+0.06/-0.02	3.06	3.50	3.50	R 37
5 ¹ / ₈	11.00	8	1 ¹ / ₄ -8	1.38	+0.06/-0.02	3.44	4.00	—	R 41
7 ¹ / ₁₆	12.50	12	1 ¹ / ₈ -8	1.25	+0.06/-0.02	3.69	4.50	—	R 45
9	15.50	12	1 ³ / ₈ -8	1.50	+0.06/-0.02	4.31	5.00	—	R 49
11	18.50	16	1 ³ / ₈ -8	1.50	+0.06/-0.02	4.56	5.25	—	R 53
13 ⁵ / ₈	21.00	20	1 ³ / ₈ -8	1.50	+0.06/-0.02	4.94	4.94	—	R 57
16 ³ / ₄	24.25	20	1 ⁵ / ₈ -8	1.75	+0.09/-0.02	5.06	5.69	—	R 66
20 ³ / ₄	29.50	20	2-8	2.12	+0.09/-0.02	6.75	6.75	—	R 74

FOOTNOTE

^a For flange sizes 26³/₄ in. and 30 in., see Table E.7.

Table E.3—Type 6B Flanges for 5000 psi

Dimensions in inches

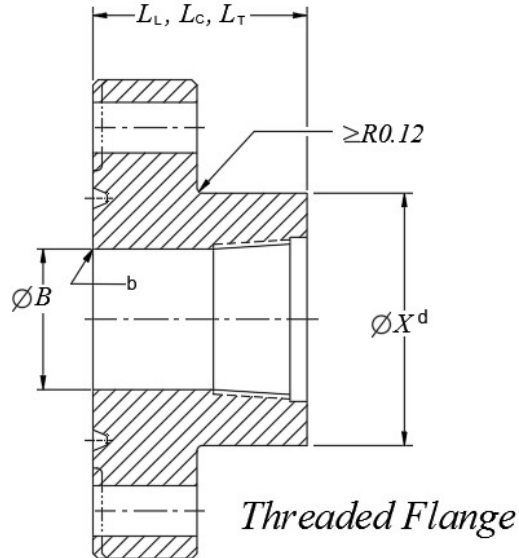
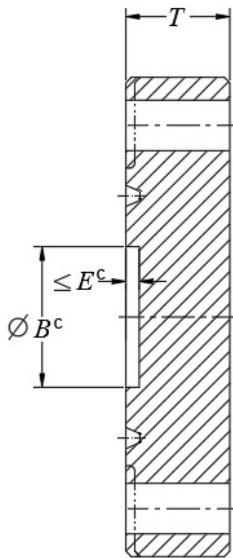
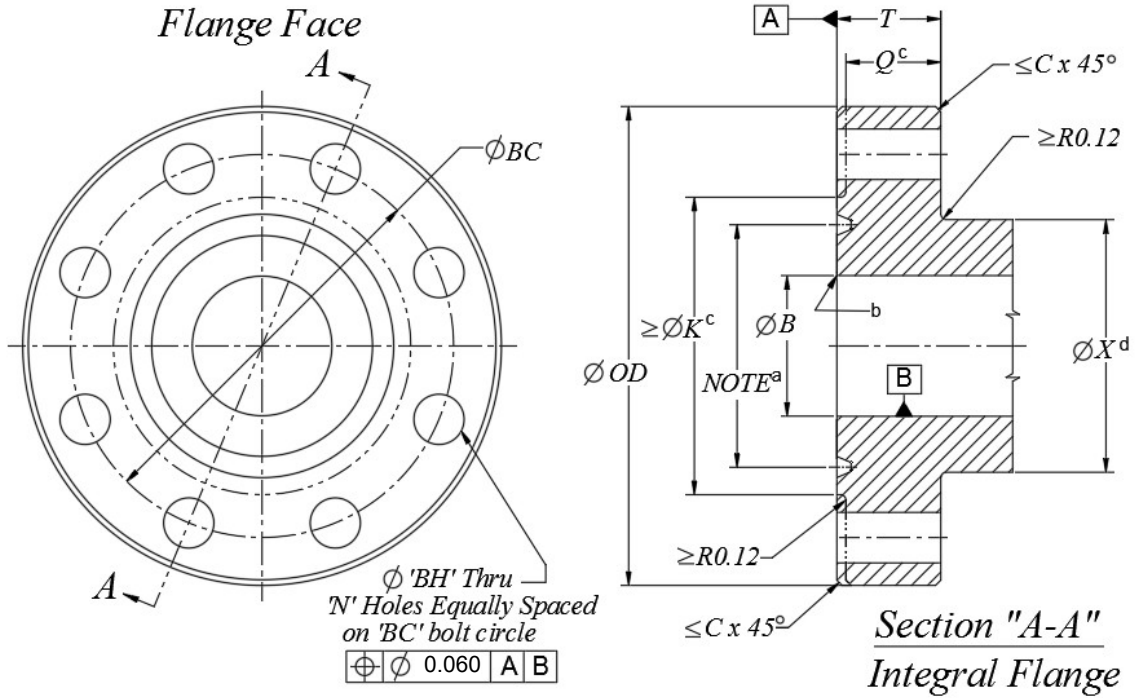

FOOTNOTES

- a Ring groove shall be concentric with bore B within 0.010 in. diametrical runout. See Table E.8 for ring groove dimensions.
- b Break sharp corner.
- c Raised face K and counterbore E are optional features.
- d Diameter X is a reference dimension.

Table E.3—Type 6B Flanges for 5000 psi (continued)

Dimensions in inches

Nominal Size of Flange ^a	Maximum Bore	Outside Diameter of Flange	Max. Chamfer	Diameter of Raised Face	Total Thickness of Flange	Basic Thickness of Flange	Diameter of Hub	Counter-bore Depth
	<i>B</i>	<i>OD</i>	<i>C</i>	<i>K</i>	<i>T</i>	<i>Q</i>	<i>X</i>	<i>E</i>
Tolerance	max.	As noted	max.	min.	+0.12/-0	min.	Reference	+0.02/-0
2 ¹ / ₁₆	2.09	8.50 ±0.06	0.12	4.88	1.81	1.50	4.12	0.31
2 ⁹ / ₁₆	2.59	9.62 ±0.06	0.12	5.38	1.94	1.62	4.88	0.31
3 ¹ / ₈	3.22	10.50 ±0.06	0.12	6.62	2.19	1.88	5.25	0.31
4 ¹ / ₁₆	4.28	12.25 ±0.06	0.12	7.62	2.44	2.12	6.38	0.31
5 ¹ / ₈	5.16	14.75 ±0.06	0.12	9.00	3.19	2.88	7.75	0.31
7 ¹ / ₁₆	7.16	15.50 ±0.12	0.25	9.75	3.62	3.25	9.00	0.38
9	9.03	19.00 ±0.12	0.25	12.50	4.06	3.62	11.50	0.44
11	11.03	23.00 ±0.12	0.25	14.63	4.69	4.25	14.50	0.44

FOOTNOTE

^a For flange sizes 13⁵/₈ in., 16³/₄ in., 18³/₄ in., and 21¹/₄ in., see Table E.7.

Nominal Size of Flange ^a	Diameter of Bolt Circle	Number of Bolts	Bolt Size and TPI	Bolt Holes		Hub Length, Threaded Flange			Ring Groove
						Line Pipe Flange	Casing Flange	Tubing Flange	
	<i>BC</i>	<i>N</i>		<i>BH</i>		<i>L_L</i>	<i>L_C</i>	<i>L_T</i>	
Tolerance>	See figure for GDT	(Ref.)		Diameter	Tolerance	min.	min.	min.	
2 ¹ / ₁₆	6.50	8	7/8-9	1.00	+0.06/-0.02	2.56	—	2.56	R 24
2 ⁹ / ₁₆	7.50	8	1-8	1.12	+0.06/-0.02	2.81	—	2.81	R 27
3 ¹ / ₈	8.00	8	1 ¹ / ₈ -8	1.25	+0.06/-0.02	3.19	—	3.19	R 35
4 ¹ / ₁₆	9.50	8	1 ¹ / ₄ -8	1.38	+0.06/-0.02	3.88	3.88	3.88	R 39
5 ¹ / ₈	11.50	8	1 ¹ / ₂ -8	1.62	+0.06/-0.02	4.44	4.44	—	R 44
7 ¹ / ₁₆	12.50	12	1 ³ / ₈ -8	1.50	+0.06/-0.02	5.06	5.06	—	R 46
9	15.50	12	1 ⁵ / ₈ -8	1.75	+0.09/-0.02	6.06	6.06	—	R 50
11	19.00	12	1 ⁷ / ₈ -8	2.00	+0.09/-0.02	6.69	6.69	—	R 54

FOOTNOTE

^a For flange sizes 13⁵/₈ in., 16³/₄ in., 18³/₄ in., and 21¹/₄ in., see Table E.7.

Table E.4—Type 6BX Flanges for 10,000 psi

Dimensions in inches

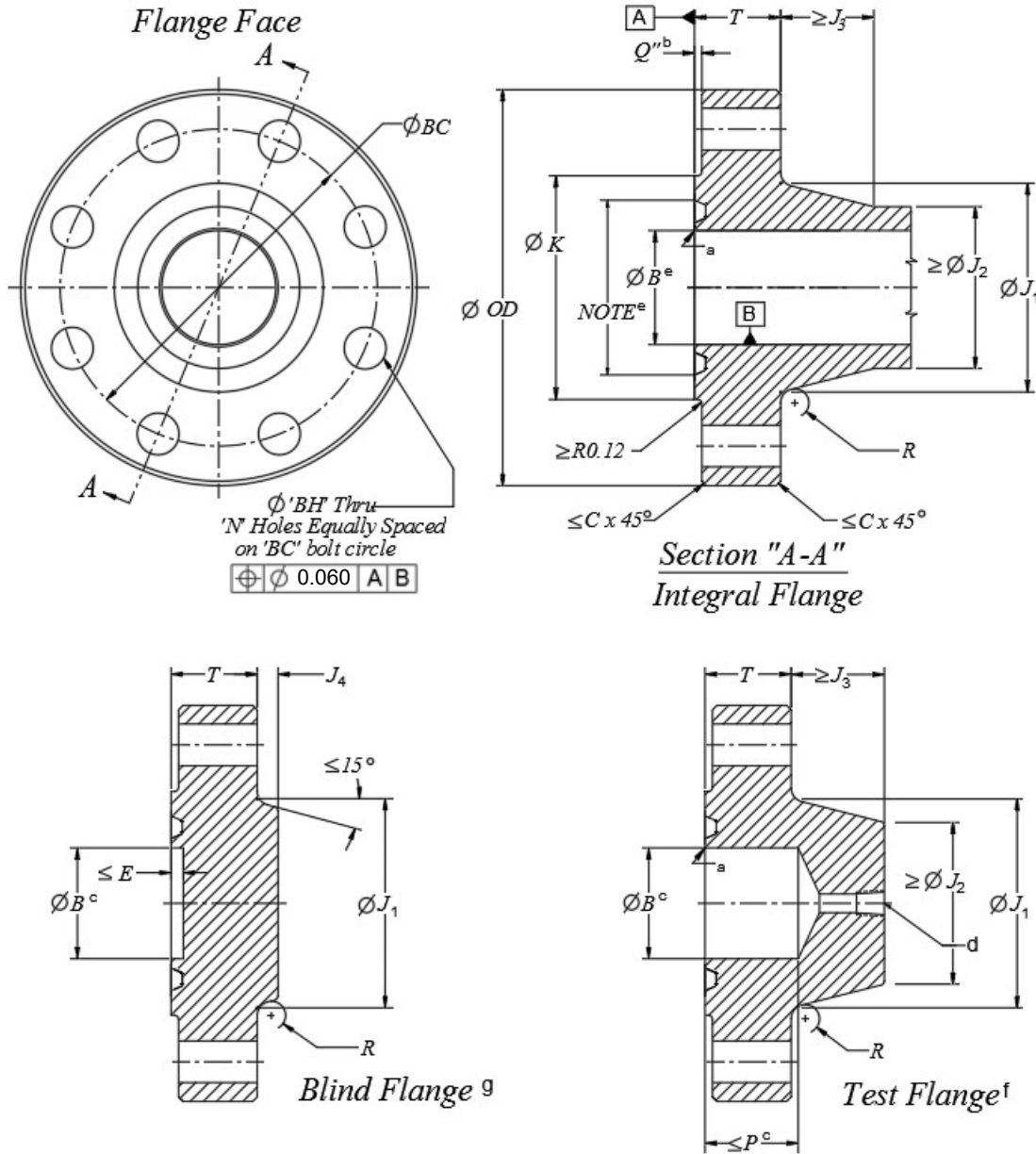

FOOTNOTES

- a Break sharp corner.
- b Q'' max. = E ; Q'' min. = 0.12 in. See Table E.11 for value of E if not listed. Raised face ($\varnothing K$) may be omitted on studed connectors, but thickness T shall still apply.
- c Optional feature.
- d Test connection shall be $1/2$ in. NPT or per 9.3 (Figure 5).
- e Ring groove shall be concentric with bore B within 0.010 in. diametrical runout. See Table E.11 for ring groove dimensions.
- f Test flange style—applies to sizes $1^{13}/16$ through $5^{1}/8$ only.
- g Blind flange style—applies to sizes $5^{1}/8$ through $21^{1}/4$ only.
- h If the minimum value of J_3 is exceeded, the maximum depth P of the counterbore may be increased by the same amount or less.

Table E.4—Type 6BX Flanges for 10,000 psi (continued)

Dimensions in inches

Nominal Size	Maximum Bore	Outside Diameter of Flange	Diameter of Raised Face	Total Thickness	Max. Chamfer	Large Hub Diameter	Small Hub Diameter	Length of Hub	Hub Height
	<i>B</i>	<i>OD</i>	<i>K</i>	<i>T</i>	<i>C</i>	<i>J₁</i>	<i>J₂</i>	<i>J₃</i>	<i>J₄</i>
Tolerance	max.	As noted	± 0.06	+0.12/-0	max.	+0/-0.12	min.	min.	min. ^h
1 ¹³ / ₁₆	1.84	7.38 ±0.06	4.12	1.66	0.12	3.50	2.56	1.91	—
2 ¹ / ₁₆	2.09	7.88 ±0.06	4.38	1.73	0.12	3.94	2.94	2.03	—
2 ⁹ / ₁₆	2.59	9.12 ±0.06	5.19	2.02	0.12	4.75	3.62	2.25	—
3 ¹ / ₁₆	3.09	10.62 ±0.06	6.00	2.30	0.12	5.59	4.34	2.50	—
4 ¹ / ₁₆	4.09	12.44 ±0.06	7.28	2.77	0.12	7.19	5.75	2.88	—
5 ¹ / ₈	5.16	14.06 ±0.06	8.69	3.12	0.12	8.81	7.19	3.19	0.25
7 ¹ / ₁₆	7.09	18.88 ±0.12	11.88	4.06	0.25	11.88	10.00	3.75	0.38
9	9.03	21.75 ±0.12	14.12	4.88	0.25	14.75	12.88	3.69	0.38
11	11.03	25.75 ±0.12	16.88	5.56	0.25	17.75	15.75	4.06	0.56
13 ⁵ / ₈	13.66	30.25 ±0.12	20.38	6.62	0.25	21.75	19.50	4.50	0.69
16 ³ / ₄	16.78	34.31 ±0.12	22.69	6.62	0.25	25.81	23.69	3.00	1.19
18 ³ / ₄	18.78	40.94 ±0.12	27.44	8.78	0.25	29.62	26.56	6.12	1.00
21 ¹ / ₄	21.28	45.00 ±0.12	30.75	9.50	0.25	33.38	30.00	6.50	1.25

Nominal Size	Radius of Hub	Bolt Circle	Number of Bolts	Bolt Size and TPI	Bolt Holes		Counterbore Depth		Ring Groove
					<i>BH</i>		<i>E</i>	<i>P^h</i>	
Tolerance	± 0.06	See figure for GDT		(Ref.)	Diameter	Tolerance	max.	max.	
1 ¹³ / ₁₆	0.38	5.75	8	3/4-10	0.88	+0.06/-0.02	0.240	1.89	BX 151
2 ¹ / ₁₆	0.38	6.25	8	3/4-10	0.88	+0.06/-0.02	0.250	2.02	BX 152
2 ⁹ / ₁₆	0.38	7.25	8	7/8-9	1.00	+0.06/-0.02	0.290	2.42	BX 153
3 ¹ / ₁₆	0.38	8.50	8	1-8	1.12	+0.06/-0.02	0.320	2.83	BX 154
4 ¹ / ₁₆	0.38	10.19	8	1 1/8-8	1.25	+0.06/-0.02	0.350	3.45	BX 155
5 ¹ / ₈	038	11.81	12	1 1/8-8	1.25	+0.06/-0.02	0.375	3.86	BX 169
7 ¹ / ₁₆	0.62	15.88	12	1 1/2-8	1.62	+0.09/-0.02	0.438	—	BX 156
9	0.62	18.75	16	1 1/2-8	1.62	+0.09/-0.02	0.500	—	BX 157
11	0.62	22.25	16	1 3/4-8	1.88	+0.09/-0.02	0.562	—	BX 158
13 ⁵ / ₈	0.62	26.50	20	1 7/8-8	2.00	+0.09/-0.02	0.625	—	BX 159
16 ³ / ₄	0.75	30.56	24	1 7/8-8	2.00	+0.09/-0.02	0.328	—	BX 162
18 ³ / ₄	0.62	36.44	24	2 1/4-8	2.38	+0.09/-0.02	0.719	—	BX 164
21 ¹ / ₄	0.81	40.25	24	2 1/2-8	2.62	+0.09/-0.02	0.750	—	BX 166

Table E.5—Type 6BX Flanges for 15,000 psi

Dimensions in inches

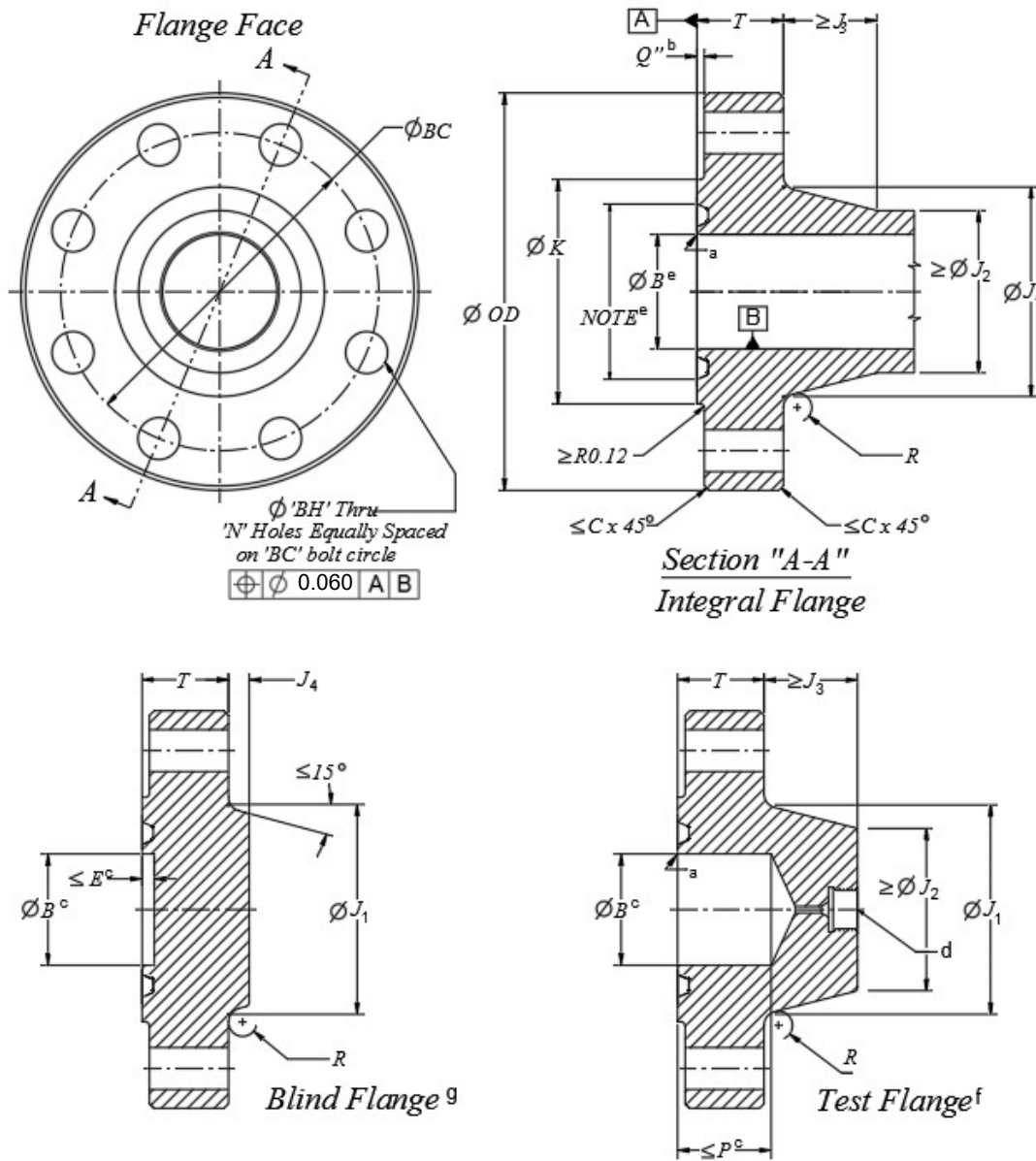

FOOTNOTES

- a Break-sharp corner.
- b Q'' max. = E ; Q'' min. = 0.12 in. See Table E.11 for value of E if not listed. Raised face (ϕK) may be omitted on studed connectors, but thickness T shall still apply.
- c Optional feature.
- d Test connection shall be per 9.3 (Figure 5).
- e Ring groove shall be concentric with bore B within 0.010 in. diametrical runout. See Table E.11 for ring groove dimensions.
- f Test flange style—applies to sizes $1^{13}/_{16}$ through $5^{1}/_8$ only.
- g Blind flange style—applies to sizes $5^{1}/_8$ through $18^{3}/_4$ only.
- h If the minimum value of J_3 is exceeded, the maximum depth P of the counterbore may be increased by the same amount or less.

Table E.5—Type 6BX Flanges for 15,000 psi (continued)

Dimensions in inches

Nominal Size of Flange	Maximum Bore <i>B</i>	Outside Diameter of Flange <i>OD</i>	Diameter of Raised Face <i>K</i>	Total Thickness of Flange <i>T</i>	Max. Chamfer <i>C</i>	Large Hub Diameter <i>J₁</i>	Small Hub Diameter <i>J₂</i>	Hub Length <i>J₃</i>	Test Flange C'bore Depth <i>p^h</i>
Tolerance	max.	As noted	± 0.06	+0.12/-0	max.	+0/-0.12	min.	min.	max. ^h
1 ¹³ / ₁₆	1.84	8.19 ±0.06	4.19	1.78	0.12	3.84	2.81	1.88	1.98
2 ¹ / ₁₆	2.09	8.75 ±0.06	4.50	2.00	0.12	4.38	3.25	2.12	2.38
2 ⁹ / ₁₆	2.59	10.00 ±0.06	5.25	2.25	0.12	5.06	3.94	2.25	2.65
3 ¹ / ₁₆	3.09	11.31 ±0.06	6.06	2.53	0.12	6.06	4.81	2.50	3.06
4 ¹ / ₁₆	4.09	14.19 ±0.06	7.62	3.09	0.12	7.69	6.25	2.88	3.77
5 ¹ / ₈	5.16	16.50 ±0.06	8.88	3.88	0.12	9.62	7.88	3.22	4.65
7 ¹ / ₁₆	7.09	19.88 ±0.12	12.00	4.69	0.25	12.81	10.88	3.62	—
9	9.03	25.50 ±0.12	15.00	5.75	0.25	17.00	13.75	4.88	—
11	11.03	32.00 ±0.12	17.88	7.38	0.25	23.00	16.81	9.28	—
13 ⁵ / ₈	13.66	34.88 ±0.12	21.31	8.06	0.25	23.44	20.81	4.50	—
18 ³ / ₄	18.78	45.75 ±0.12	28.44	10.06	0.25	32.00	28.75	6.12	—

Nominal Size of Flange	Radius of Hub <i>R</i>	Bolt Circle <i>BC</i>	Number of Bolts <i>N</i>	Bolt Size and TPI (Ref.)	Bolt Holes <i>BH</i>		Blind Flange		Ring Groove
					Diameter	Tolerance	Counter-bore Depth <i>E</i>	Hub Height <i>J₄</i>	
Tolerance	± 0.06	See figure for GDT			Diameter	Tolerance	max.	min.	
1 ¹³ / ₁₆	0.38	6.31	8	7/8-9	1.00	+0.06/-0.02	—	—	BX 151
2 ¹ / ₁₆	0.38	6.88	8	7/8-9	1.00	+0.06/-0.02	—	—	BX 152
2 ⁹ / ₁₆	0.38	7.88	8	1-8	1.12	+0.06/-0.02	—	—	BX 153
3 ¹ / ₁₆	0.38	9.06	8	1 ¹ / ₈ -8	1.25	+0.06/-0.02	—	—	BX 154
4 ¹ / ₁₆	0.38	11.44	8	1 ³ / ₈ -8	1.50	+0.06/-0.02	—	—	BX 155
5 ¹ / ₈	0.62	13.50	12	1 ¹ / ₂ -8	1.62	+0.09/-0.02	0.375	0.25	BX 169
7 ¹ / ₁₆	0.62	16.88	16	1 ¹ / ₂ -8	1.62	+0.09/-0.02	0.438	0.31	BX 156
9	0.62	21.75	16	1 ⁷ / ₈ -8	2.00	+0.09/-0.02	0.500	0.56	BX 157
11	0.62	28.00	20	2-8	2.12	+0.09/-0.02	0.562	0.50	BX 158
13 ⁵ / ₈	1.00	30.38	20	2 ¹ / ₄ -8	2.38	+0.09/-0.02	0.625	0.69	BX 159
18 ³ / ₄	1.00	40.00	20	3-8	3.12	+0.12/-0.02	0.719	1.38	BX 164

Table E.6—Type 6BX Flanges for 20,000 psi

Dimensions in inches

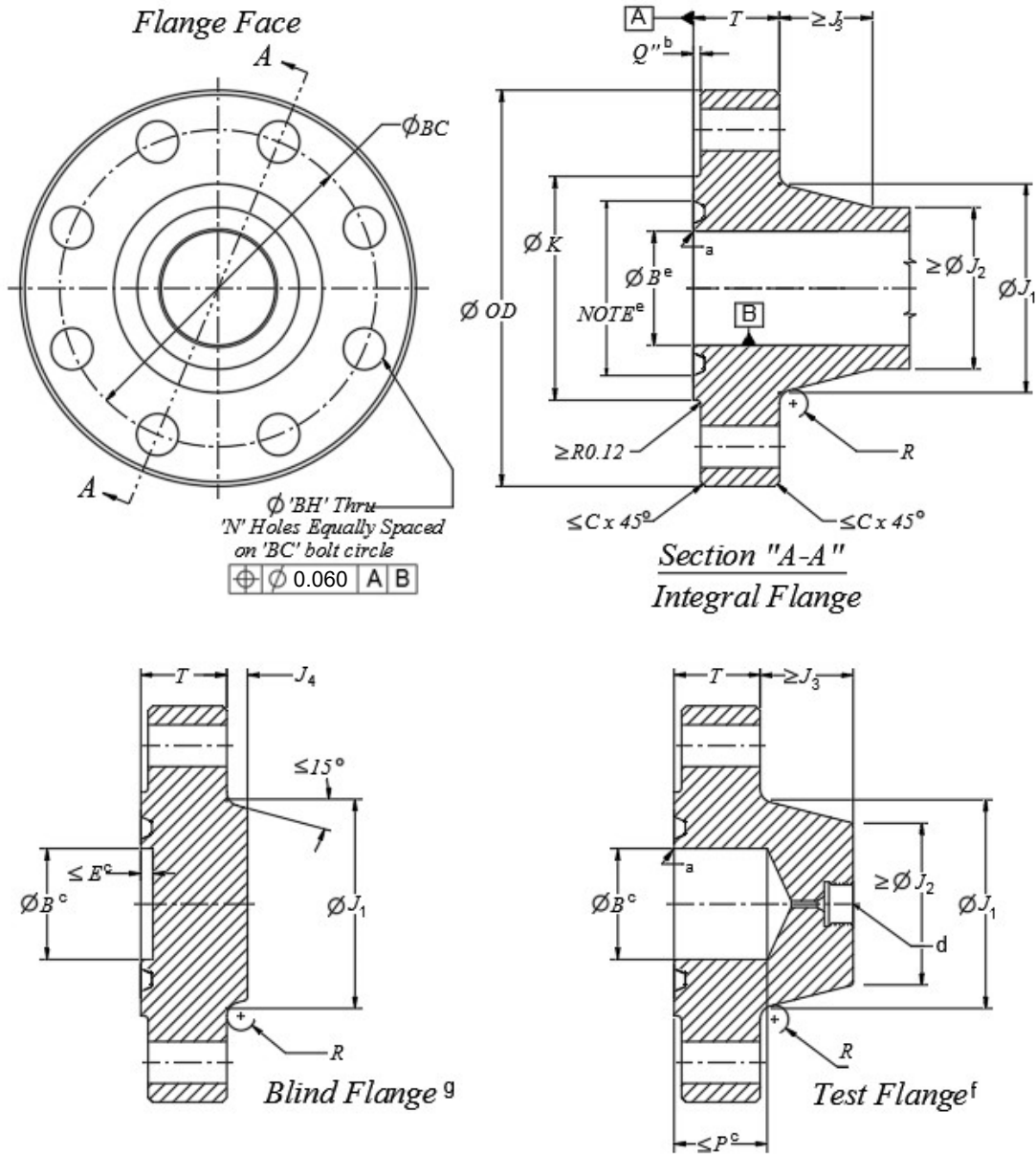

FOOTNOTES

- a Break sharp corner.
- b Q'' max. = E ; Q'' min. = 0.12 in. See Table E.11 for value of E if not listed. Raised face (ϕK) may be omitted on studded connectors, but thickness T shall still apply.
- c Optional feature.
- d Test connection shall be per 9.3 (Figure 5).
- e Ring groove shall be concentric with bore B within 0.010 in. diametrical runout. See Table E.11 for ring groove dimensions.
- f Test flange style—applies to sizes $1^{13}/_{16}$ through $4^{1}/_{16}$ only.
- g Blind flange style—applies to sizes $7^{1}/_{16}$ through $18^{3}/_{4}$ only.
- h If the minimum value of J_3 is exceeded, the maximum depth P of the counterbore may be increased by the same amount or less.

Table E.6—Type 6BX Flanges for 20,000 psi (continued)

Dimensions in inches

Nominal Size of Flange	Maximum Bore <i>B</i>	Outside Diameter of Flange <i>OD</i>	Diameter of Raised Face <i>K</i>	Total Thickness of Flange <i>T</i>	Max. Chamfer <i>C</i>	Large Hub Diameter <i>J₁</i>	Small Hub Diameter <i>J₂</i>	Hub Length <i>J₃</i>	Test Flange C'bore Depth <i>P^h</i>
Tolerance	max.	As noted	± 0.06	+0.12/−0	max.	+0/−0.12	min.	min.	max. ^h
1 ¹³ / ₁₆	1.84	10.12 ±0.06	4.62	2.50	0.12	5.25	4.31	1.94	2.50
2 ¹ / ₁₆	2.09	11.31 ±0.06	5.19	2.81	0.12	6.06	5.00	2.06	2.50
2 ⁹ / ₁₆	2.59	12.81 ±0.06	5.94	3.12	0.12	6.81	5.69	2.31	2.50
3 ¹ / ₁₆	3.09	14.06 ±0.06	6.75	3.38	0.12	7.56	6.31	2.50	2.50
4 ¹ / ₁₆	4.09	17.56 ±0.06	8.62	4.19	0.12	9.56	8.12	2.88	2.50
7 ¹ / ₁₆	7.09	25.81 ±0.12	13.88	6.50	0.25	15.19	13.31	3.81	—
9	9.03	31.69 ±0.12	17.38	8.06	0.25	18.94	16.88	4.25	—
11	11.03	34.75 ±0.12	19.88	8.81	0.25	22.31	20.00	4.06	—
13 ⁵ / ₈	13.66	45.75 ±0.12	24.19	11.50	0.25	27.31	24.75	5.25	—

Nominal Size of Flange	Radius of Hub <i>R</i>	Bolt Circle <i>BC</i>	Number of Bolts <i>N</i>	Bolt Size and TPI	Bolt Holes		Blind Flange		Ring Groove
					<i>BH</i>		C'bore Depth <i>E</i>	Hub Height <i>J₄</i>	
Tolerance	± 0.60	See figure for GDT		(Ref.)	Diameter	Tolerance	max.	min.	
1 ¹³ / ₁₆	0.38	8.00	8	1-8	1.12	+0.06/−0.02	—	—	BX 151
2 ¹ / ₁₆	0.38	9.06	8	1 ¹ / ₈ -8	1.25	+0.06/−0.02	—	—	BX 152
2 ⁹ / ₁₆	0.38	10.31	8	1 ¹ / ₄ -8	1.38	+0.06/−0.02	—	—	BX 153
3 ¹ / ₁₆	0.38	11.31	8	1 ³ / ₈ -8	1.50	+0.06/−0.02	—	—	BX 154
4 ¹ / ₁₆	0.38	14.06	8	1 ³ / ₄ -8	1.88	+0.09/−0.02	—	—	BX 155
7 ¹ / ₁₆	0.62	21.81	16	2-8	2.12	+0.09/−0.02	0.438	0.31	BX 156
9	1.00	27.00	16	2 ¹ / ₂ -8	2.62	+0.09/−0.02	0.500	0.25	BX 157
11	1.00	29.50	16	2 ³ / ₄ -8	2.88	+0.09/−0.02	0.562	0.50	BX 158
13 ⁵ / ₈	1.00	40.00	20	3-8	3.12	+0.12/−0.02	0.625	0.56	BX 159

Table E.7—Type 6BX Large-bore Flanges for 2000 psi, 3000 psi, and 5000 psi

Dimensions in inches

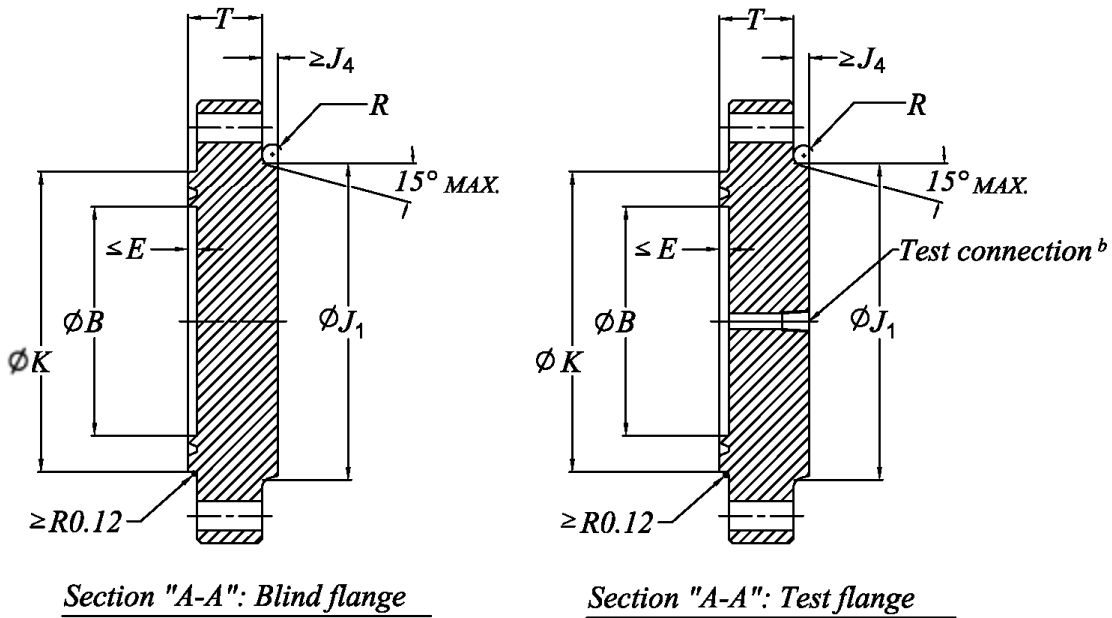
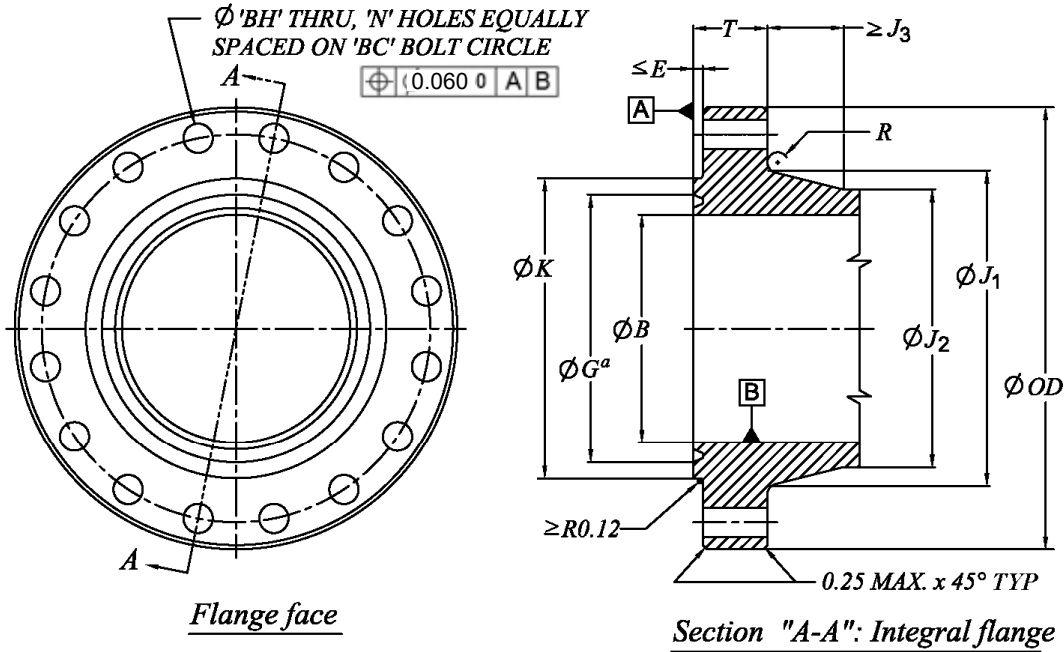

FOOTNOTES

- a Ring groove shall be concentric with bore *B* within 0.010 in. diametrical runout. See Table E.11 for ring groove dimensions.
- b Test connection shall be 1/2 in. NPT or per 9.3 (Figure 5).
- c *Q''* min. = 0.12 in. (may be omitted for studed flanges).
- d Counterbore *E* for blind and test flanges is optional.
- e Break sharp corner.

Table E.7—Type 6BX Large-bore Flanges for 2000 psi, 3000 psi, and 5000 psi (continued)

Dimensions in inches

Nominal Size	Maximum Bore <i>B</i>	Outside Diameter of Flange <i>OD</i>	Raised Face Depth <i>Q</i> "	Raised Face Diameter <i>K</i>	Total Thickness <i>T</i>	Large Hub Diameter <i>J</i> ₁	Small Hub Diameter <i>J</i> ₂	Length of Hub <i>J</i> ₃
Tolerance	max.	As noted	max.	± 0.06	+0.12/-0	+0/-0.12	min.	min.
2000 psi								
26 ³ / ₄	26.78	41.00 ±0.12	0.25	31.69	4.97	32.91	29.25	7.31
30	30.03	44.19 ±0.12	0.25	35.75	5.28	36.69	32.80	7.75
3000 psi								
26 ³ / ₄	26.78	43.38 ±0.12	0.25	32.75	6.34	34.25	30.56	7.31
30	30.03	46.68 ±0.12	0.25	36.31	6.58	38.19	34.30	7.75
5000 psi								
13 ⁵ / ₈	13.66	26.50 ±0.12	0.25	18.00	4.44	18.94	16.69	4.50
16 ³ / ₄	16.78	30.38 ±0.12	0.25	21.06	5.12	21.88	20.75	3.00
18 ³ / ₄	18.78	35.62 ±0.12	0.25	24.69	6.53	26.56	23.56	6.00
21 ¹ / ₄	21.28	39.00 ±0.12	0.25	27.62	7.12	29.88	26.75	6.50

Nominal Size	Radius of Hub <i>R</i>	Bolt Circle <i>BC</i>	Number of Bolts <i>N</i>	Bolt Size and TPI	Bolt Hole Diameter <i>BH</i>	Blind Flange		Ring Groove
						Counter-bore Depth <i>E</i>	Hub Height <i>J</i> ₄	
Tolerance	± 0.06	See figure for GDT		(Ref.)	+0.09/-0.02	max.	min.	
2000 psi								
26 ³ / ₄	0.62	37.50	20	1 ³ / ₄ -8	1.88	0.844	0.38	BX 167
30	0.62	40.94	32	1 ⁵ / ₈ -8	1.75	0.906	0.69	BX 303
3000 psi								
26 ³ / ₄	0.62	39.38	24	2-8	2.12	0.844	0.00	BX 168
30	0.62	42.94	32	1 ⁷ / ₈ -8	2.00	0.906	0.50	BX 303
5000 psi								
13 ⁵ / ₈	0.62	23.25	16	1 ⁵ / ₈ -8	1.75	0.562	0.94	BX 160
16 ³ / ₄	0.75	26.62	16	1 ⁷ / ₈ -8	2.00	0.328	0.69	BX 162
18 ³ / ₄	0.62	31.62	20	2-8	2.12	0.719	0.75	BX 163
21 ¹ / ₄	0.69	34.88	24	2-8	2.12	0.750	0.88	BX 165

Table E.8—Type R Ring Grooves

Dimensions in inches; surface roughness in microinches

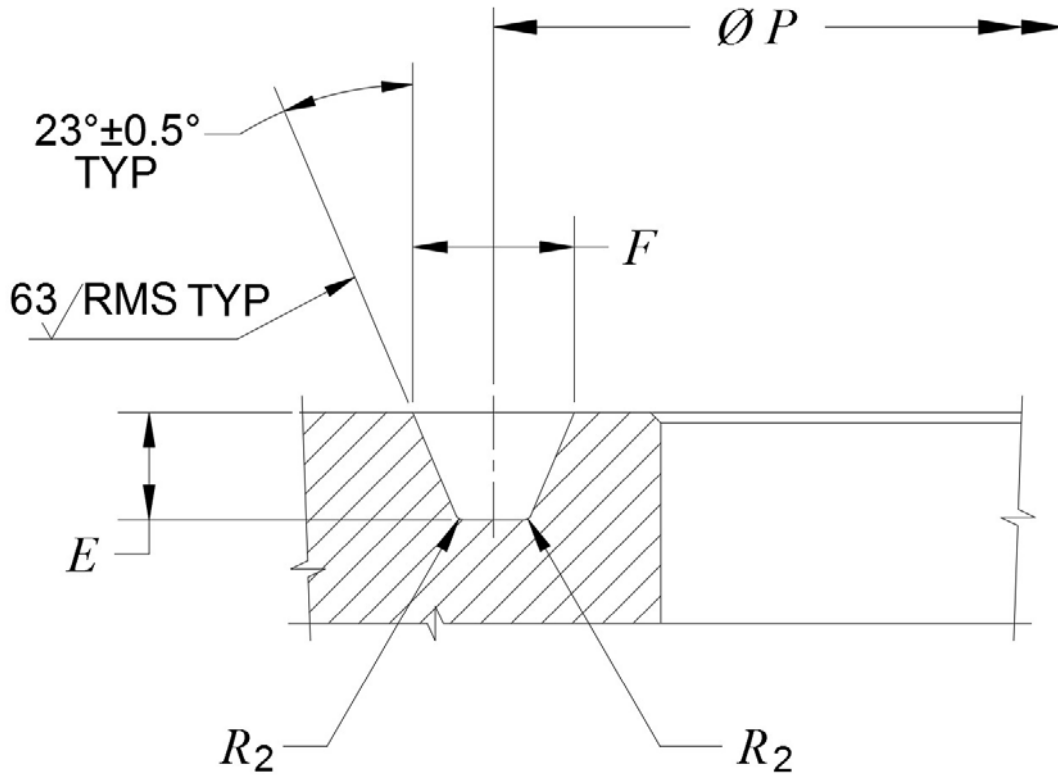

Table E.8—Type R Ring Grooves *(continued)*

Dimensions in inches

Groove Number	Nominal Size of Flange in.	Pitch Diameter <i>P</i>	Depth of Groove <i>E</i>	Width of Groove <i>F</i>	Radius in Groove <i>R</i> ₂
Tolerance>	(Ref.)	± 0.005	+0.02/-0	± 0.008	max.
R 23	2 ¹ / ₁₆	3.250	0.31	0.469	0.03
R 24	2 ¹ / ₁₆	3.750	0.31	0.469	0.03
R 26	2 ⁹ / ₁₆	4.000	0.31	0.469	0.03
R 27	2 ⁹ / ₁₆	4.250	0.31	0.469	0.03
R 31	3 ¹ / ₈	4.875	0.31	0.469	0.03
R 35	3 ¹ / ₈	5.375	0.31	0.469	0.03
R 37	4 ¹ / ₁₆	5.875	0.31	0.469	0.03
R 39	4 ¹ / ₁₆	6.375	0.31	0.469	0.03
R 41	5 ¹ / ₈	7.125	0.31	0.469	0.03
R 44	5 ¹ / ₈	7.625	0.31	0.469	0.03
R 45	7 ¹ / ₁₆	8.313	0.31	0.469	0.03
R 46	7 ¹ / ₁₆	8.313	0.38	0.531	0.06
R 49	9	10.625	0.31	0.469	0.03
R 50	9	10.625	0.44	0.656	0.06
R 53	11	12.750	0.31	0.469	0.03
R 54	11	12.750	0.44	0.656	0.06
R 57	13 ⁵ / ₈	15.000	0.31	0.469	0.03
R 65	16 ³ / ₄	18.500	0.31	0.469	0.03
R 66	16 ³ / ₄	18.500	0.44	0.656	0.06
R 73	21 ¹ / ₄	23.000	0.38	0.531	0.06
R 74	20 ³ / ₄	23.000	0.50	0.781	0.06

Table E.9—Type R Ring Gaskets

Dimensions in inches; surface roughness in microinches

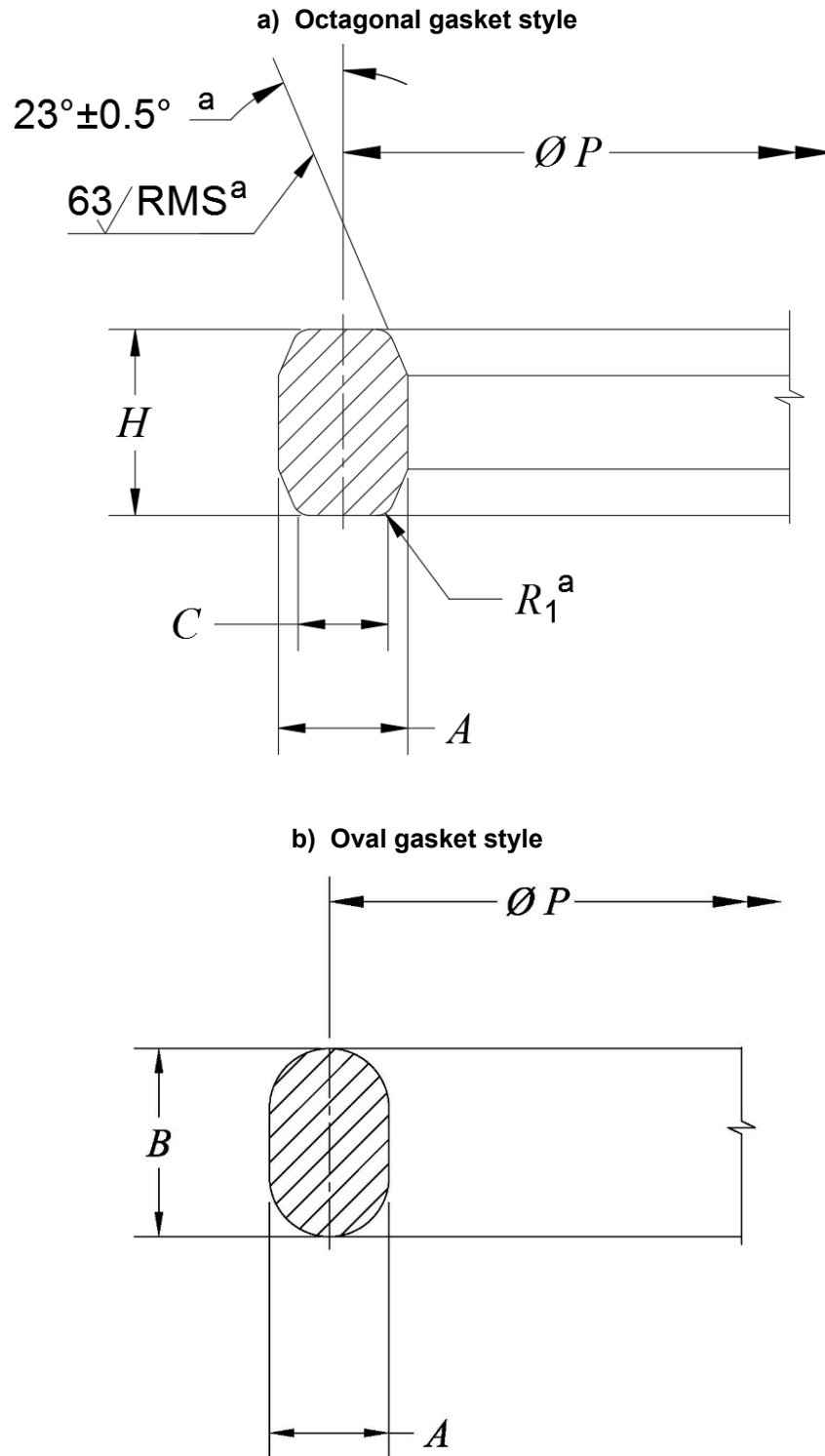

FOOTNOTE

^a Typical four places.

Table E.9—Type R Ring Gaskets *(continued)*

Dimensions in inches

Gasket Number	Pitch Diameter	Width of Ring	Height of Oval Ring	Height of Octagonal Ring	Width of Flat on Octagonal Ring	Radius on Octagonal Ring	Distance between Flanges
	<i>P</i>	<i>A</i>	<i>B</i>	<i>H</i>	<i>C</i>	<i>R</i> ₁	<i>S</i>
Tolerance>	± 0.007	± 0.008	± 0.02	± 0.02	± 0.008	± 0.02	(Approx.)
R 23	3.250	0.438	0.69	0.63	0.305	0.06	0.19
R 24	3.750	0.438	0.69	0.63	0.305	0.06	0.19
R 26	4.000	0.438	0.69	0.63	0.305	0.06	0.19
R 27	4.250	0.438	0.69	0.63	0.305	0.06	0.19
R 31	4.875	0.438	0.69	0.63	0.305	0.06	0.19
R 35	5.375	0.438	0.69	0.63	0.305	0.06	0.19
R 37	5.875	0.438	0.69	0.63	0.305	0.06	0.19
R 39	6.375	0.438	0.69	0.63	0.305	0.06	0.19
R 41	7.125	0.438	0.69	0.63	0.305	0.06	0.19
R 44	7.625	0.438	0.69	0.63	0.305	0.06	0.19
R 45	8.313	0.438	0.69	0.63	0.305	0.06	0.19
R 46	8.313	0.500	0.75	0.69	0.341	0.06	0.19
R 49	10.625	0.438	0.69	0.63	0.305	0.06	0.19
R 50	10.625	0.625	0.88	0.81	0.413	0.06	0.16
R 53	12.750	0.438	0.69	0.63	0.305	0.06	0.19
R 54	12.750	0.625	0.88	0.81	0.413	0.06	0.16
R 57	15.000	0.438	0.69	0.63	0.305	0.06	0.19
R 65	18.500	0.438	0.69	0.63	0.305	0.06	0.19
R 66	18.500	0.625	0.88	0.81	0.413	0.06	0.16
R 73	23.000	0.500	0.75	0.69	0.341	0.06	0.13
R 74	23.000	0.750	1.00	0.94	0.485	0.06	0.19

Table E.10—Type RX Ring Gaskets

Dimensions in inches; surface roughness in microinches

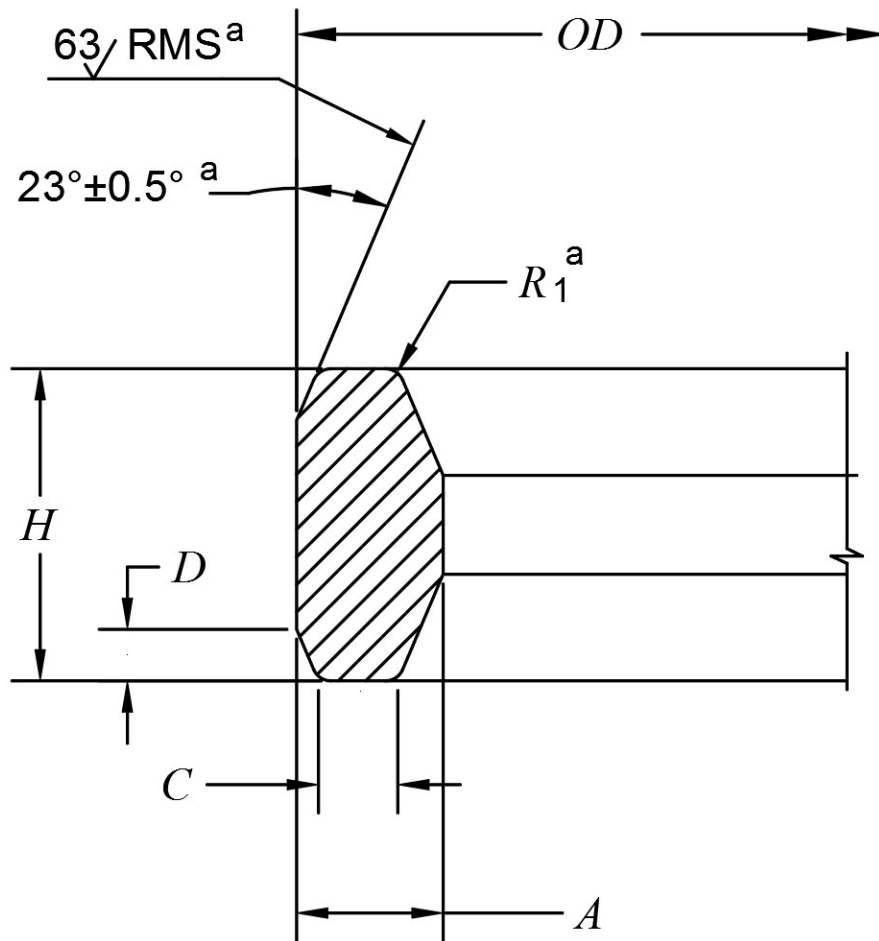

FOOTNOTE

^a Typical four places.

Table E.10—Type RX Ring Gaskets *(continued)*

Dimensions in inches

Groove Number	Outside Diameter	Width of Ring	Width of Flat	Height of Ring	Height of OD Bevel	Radius on Ring	Distance between Flanges
	<i>OD</i>	<i>A</i> ^a	<i>C</i>	<i>H</i> ^a	<i>D</i>	<i>R</i> ₁	<i>S</i>
Tolerance>	+0.020/-0	+0.008/-0	+0.006/-0	+0.008/-0	+0/-0.030	± 0.02	(Approx.)
RX 23	3.672	0.469	0.254	1.000	0.167	0.06	0.47
RX 24	4.172	0.469	0.254	1.000	0.167	0.06	0.47
RX 26	4.406	0.469	0.254	1.000	0.167	0.06	0.47
RX 27	4.656	0.469	0.254	1.000	0.167	0.06	0.47
RX 31	5.297	0.469	0.254	1.000	0.167	0.06	0.47
RX 35	5.797	0.469	0.254	1.000	0.167	0.06	0.47
RX 37	6.297	0.469	0.254	1.000	0.167	0.06	0.47
RX 39	6.797	0.469	0.254	1.000	0.167	0.06	0.47
RX 41	7.547	0.469	0.254	1.000	0.167	0.06	0.47
RX 44	8.047	0.469	0.254	1.000	0.167	0.06	0.47
RX 45	8.734	0.469	0.254	1.000	0.167	0.06	0.47
RX 46	8.750	0.531	0.263	1.125	0.188	0.06	0.47
RX 49	11.047	0.469	0.254	1.000	0.167	0.06	0.47
RX 50	11.156	0.656	0.335	1.250	0.208	0.06	0.47
RX 53	13.172	0.469	0.254	1.000	0.167	0.06	0.47
RX 54	13.281	0.656	0.335	1.250	0.208	0.06	0.47
RX 57	15.422	0.469	0.254	1.000	0.167	0.06	0.47
RX 65	18.922	0.469	0.254	1.000	0.167	0.06	0.47
RX 66	19.031	0.656	0.335	1.250	0.208	0.06	0.47
RX 73	23.469	0.531	0.263	1.250	0.208	0.06	0.59
RX 74	23.656	0.781	0.407	1.625	0.271	0.09	0.72

FOOTNOTE
^a The variation in width *A* or height *H* of any ring shall not exceed 0.004 in. throughout its entire circumference.

Table E.11—Type BX Ring Grooves

Dimensions in inches; surface roughness in microinches

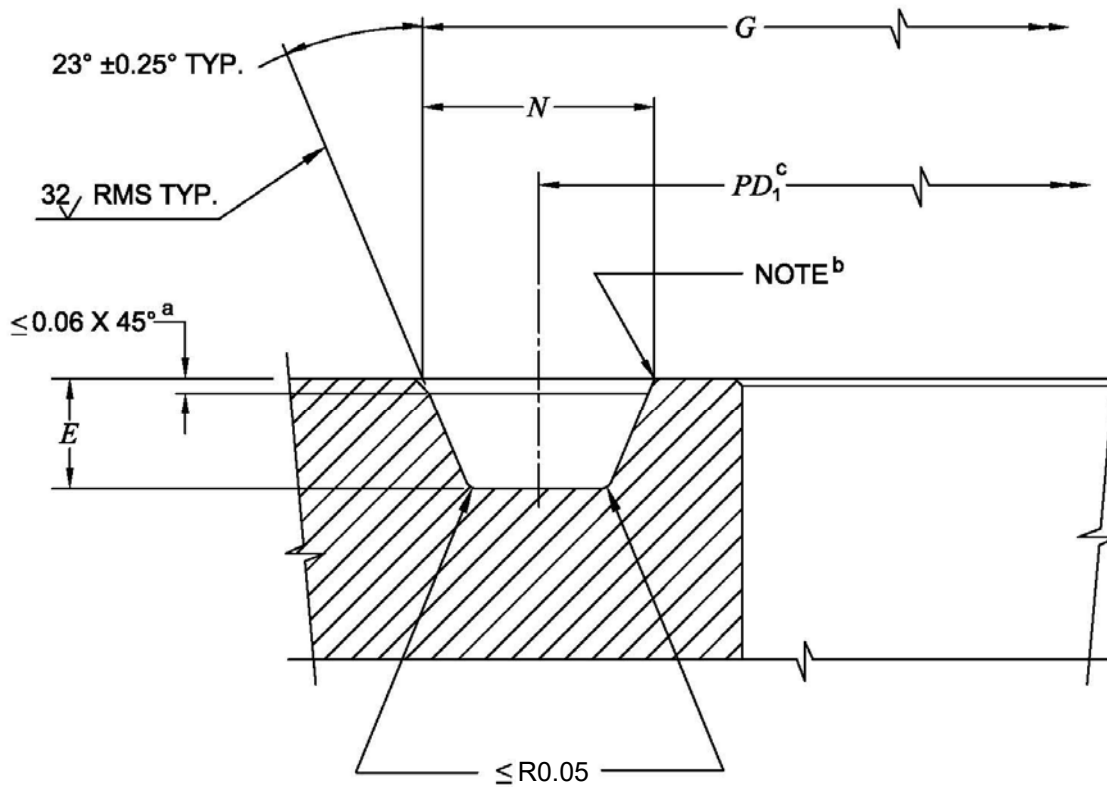

FOOTNOTES

- ^a The $0.06 \times 45^\circ$ chamfer is optional and only applies to the outside (OD) of the groove.
- ^b Break sharp corner 0.03 in. maximum at inside (ID) of the groove.
- ^c Reference dimension.

Table E.11—Type BX Ring Grooves (continued)

Dimensions in inches

Groove Number	Nominal Size of Flange	Outside Diameter	Depth of Groove	Width of Groove	Pitch Diameter of Groove	Pitch Diameter of Gasket ^a
	in.	<i>G</i>	<i>E</i>	<i>N</i>	<i>PD</i> ₁	<i>PD</i> ₂
Tolerance>	(Ref.)	+0.004/-0	+0.02/-0	+0.004/-0	(Ref.)	(Ref.)
BX 151	1 ¹³ / ₁₆	3.062	0.22	0.466	2.596	2.622
BX 152	2 ¹ / ₁₆	3.395	0.23	0.498	2.897	2.924
BX 153	2 ⁹ / ₁₆	4.046	0.27	0.554	3.492	3.519
BX 154	3 ¹ / ₁₆	4.685	0.30	0.606	4.079	4.105
BX 155	4 ¹ / ₁₆	5.930	0.33	0.698	5.232	5.253
BX 156	7 ¹ / ₁₆	9.521	0.44	0.921	8.600	8.627
BX 157	9	11.774	0.50	1.039	10.735	10.760
BX 158	11	14.064	0.56	1.149	12.915	12.942
BX 159	13 ⁵ / ₈	17.033	0.62	1.279	15.754	15.781
BX 160	13 ⁵ / ₈	16.063	0.56	0.786	15.277	15.302
BX 161	16 ³ / ₄	19.604	0.67	0.930	18.674	18.702
BX 162	16 ³ / ₄	18.832	0.33	0.705	18.127	18.153
BX 163	18 ³ / ₄	22.185	0.72	1.006	21.179	21.205
BX 164	18 ³ / ₄	22.752	0.72	1.290	21.462	21.488
BX 165	21 ¹ / ₄	24.904	0.75	1.071	23.833	23.860
BX 166	21 ¹ / ₄	25.507	0.75	1.373	24.134	24.162
BX 167	26 ³ / ₄	30.249	0.84	0.902	29.347	29.373
BX 168	26 ³ / ₄	30.481	0.84	1.018	29.463	29.489
BX 169	5 ¹ / ₈	6.955	0.38	0.666	6.289	6.315
BX 170	9	8.696	0.33	0.705	7.991	8.017
BX 171	11	10.641	0.33	0.705	9.936	9.962
BX 172	13 ⁵ / ₈	13.225	0.33	0.705	12.520	12.546
BX 303	30	33.949	0.89	1.078	32.871	32.898

FOOTNOTE
^a *PD*₂ of gaskets provided for comparison purposes. See Table E.12 for ring gasket dimensions.
Pitch diameter calculated using dimensions at middle of tolerance range.

Table E.12—Type BX Ring Gaskets

Dimensions in inches; surface roughness in microinches

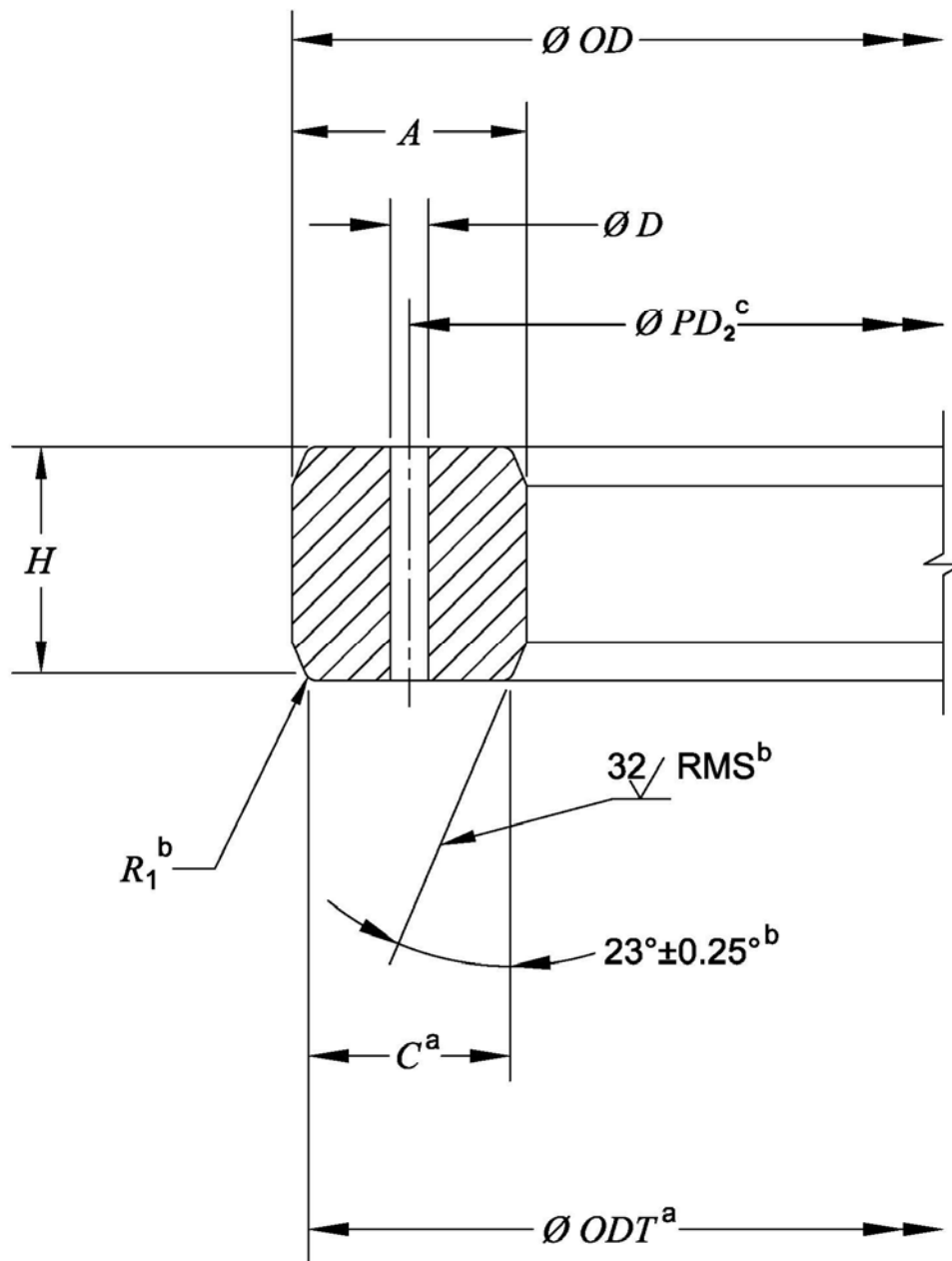

FOOTNOTES

- ^a Typical two places (top and bottom).
- ^b Typical four places (all corners).
- ^c Reference dimension (see Table E.11 for value).

Table E.12—Type BX Ring Gaskets (continued)

Dimensions in inches

Groove Number	Outside Diameter	Width of Ring ^a	Height of Ring ^a	Diameter of Flat	Width of Flat	Hole Size	Radius on Ring	
	<i>OD</i>	<i>A</i>	<i>H</i>	<i>ODT</i>	<i>C</i>	<i>D</i>	<i>R</i> ₁	
Tolerance>	+0 -0.006	+0.008 -0	+0.008 -0	± 0.002	+0.006 -0	± 0.02	min.	max.
BX 151	3.008	0.379	0.379	2.954	0.325	0.06	0.03	0.05
BX 152	3.334	0.403	0.403	3.277	0.346	0.06	0.03	0.05
BX 153	3.974	0.448	0.448	3.910	0.385	0.06	0.04	0.05
BX 154	4.600	0.488	0.488	4.531	0.419	0.06	0.04	0.06
BX 155	5.825	0.560	0.560	5.746	0.481	0.06	0.04	0.07
BX 156	9.367	0.733	0.733	9.263	0.629	0.12	0.06	0.09
BX 157	11.593	0.826	0.826	11.476	0.709	0.12	0.07	0.10
BX 158	13.860	0.911	0.911	13.731	0.782	0.12	0.07	0.11
BX 159	16.800	1.012	1.012	16.657	0.869	0.12	0.08	0.12
BX 160	15.850	0.541	0.938	15.717	0.408	0.12	0.08	0.11
BX 161	19.347	0.638	1.105	19.191	0.482	0.12	0.09	0.13
BX 162	18.720	0.560	0.560	18.641	0.481	0.06	0.04	0.07
BX 163	21.896	0.684	1.185	21.728	0.516	0.12	0.09	0.14
BX 164	22.463	0.968	1.185	22.295	0.800	0.12	0.09	0.14
BX 165	24.595	0.728	1.261	24.417	0.550	0.12	0.10	0.15
BX 166	25.198	1.029	1.261	25.020	0.851	0.12	0.10	0.15
BX 167	29.896	0.516	1.412	29.696	0.316	0.06	0.11	0.17
BX 168	30.128	0.632	1.412	29.928	0.432	0.06	0.11	0.17
BX 169	6.831	0.509	0.624	6.743	0.421	0.06	0.05	0.07
BX 170	8.584	0.560	0.560	8.505	0.481	0.06	0.04	0.07
BX 171	10.529	0.560	0.560	10.450	0.481	0.06	0.04	0.07
BX 172	13.113	0.560	0.560	13.034	0.481	0.06	0.04	0.07
BX 303	33.573	0.668	1.494	33.361	0.457	0.06	0.12	0.18

FOOTNOTE

^a The variation in width *A* or height *H* of any ring shall not exceed 0.004 in. throughout its entire circumference.

Table E.13—Flanged Crosses and Tees

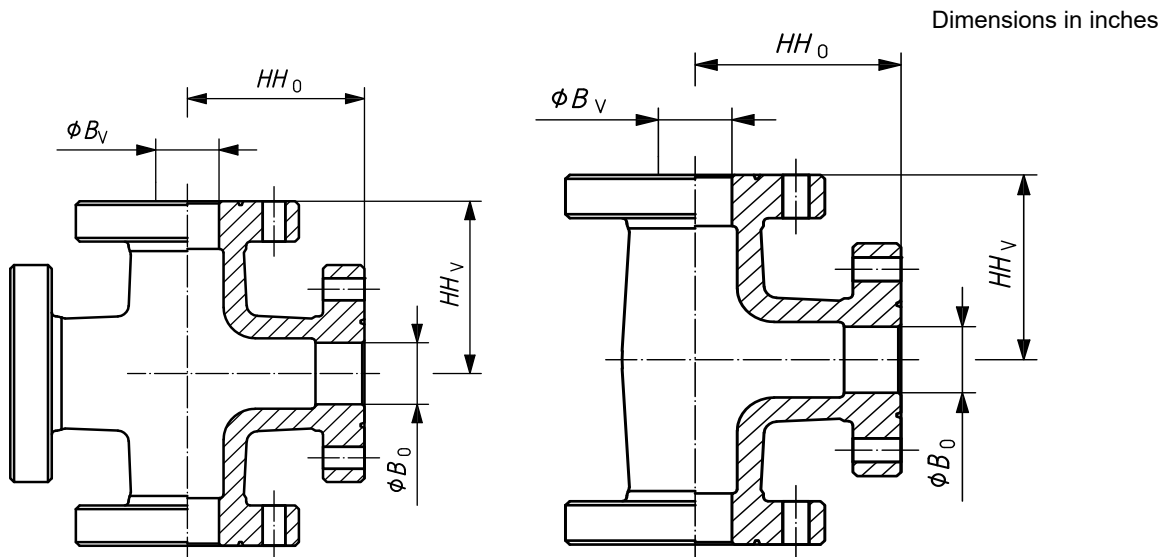

Nominal Sizes	Bore Diameter		Center-to-face Vertical Run HH_V	Center-to-face Horizontal Run HH_O
	Vertical Run B_V	Horizontal Run B_O		
Tolerance >	+0.03/-0.0	+0.03/-0.0	± 0.03	± 0.03
2000 psi				
$2^{1/16} \times 2^{1/16}$	2.06	2.06	5.81	5.81
$2^{9/16} \times 2^{1/16}$	2.56	2.06	5.94	6.31
$2^{9/16} \times 2^{9/16}$	2.56	2.56	6.56	6.56
$3^{1/8} \times 2^{1/16}$	3.12	2.06	6.06	6.69
$3^{1/8} \times 2^{9/16}$	3.12	2.56	6.56	6.81
$3^{1/8} \times 3^{1/8}$	3.12	3.12	7.06	7.06
$4^{1/16} \times 2^{1/16}$	4.06	2.06	6.31	7.94
$4^{1/16} \times 2^{9/16}$	4.06	2.56	6.81	8.06
$4^{1/16} \times 3^{1/8}$	4.06	3.12	7.19	8.19
$4^{1/16} \times 4^{1/16}$	4.06	4.06	8.56	8.56
3000 psi				
$2^{1/16} \times 2^{1/16}$	2.06	2.06	7.31	7.31
$2^{9/16} \times 2^{1/16}$	2.56	2.06	7.44	7.88
$2^{9/16} \times 2^{9/16}$	2.56	2.56	8.31	8.31
$3^{1/8} \times 2^{1/16}$	3.12	2.06	7.31	7.81
$3^{1/8} \times 2^{9/16}$	3.12	2.56	7.88	7.94
$3^{1/8} \times 3^{1/8}$	3.12	3.12	7.56	7.56
$4^{1/16} \times 2^{1/16}$	4.06	2.06	7.56	8.81
$4^{1/16} \times 2^{9/16}$	4.06	2.56	8.12	8.94
$4^{1/16} \times 3^{1/8}$	4.06	3.12	8.06	8.81
$4^{1/16} \times 4^{1/16}$	4.06	4.06	9.06	9.06

Table E.13—Flanged Crosses and Tees (continued)

Dimensions in inches

Nominal Sizes	Bore Diameter		Center-to-face Vertical Run HH_V	Center-to-face Horizontal Run HH_O
	Vertical Run B_V	Horizontal Run B_O		
Tolerance>	+0.03/-0.0	+0.03/-0.0	± 0.03	± 0.03
5000 psi				
2 ¹ / ₁₆ X 2 ¹ / ₁₆	2.06	2.06	7.31	7.31
2 ⁹ / ₁₆ X 2 ¹ / ₁₆	2.56	2.06	7.44	7.88
2 ⁹ / ₁₆ X 2 ⁹ / ₁₆	2.56	2.56	8.31	8.31
3 ¹ / ₈ X 2 ¹ / ₁₆	3.12	2.06	7.69	8.31
3 ¹ / ₈ X 2 ⁹ / ₁₆	3.12	2.56	8.25	8.44
3 ¹ / ₈ X 3 ¹ / ₈	3.12	3.12	9.31	9.31
4 ¹ / ₁₆ X 2 ¹ / ₁₆	4.06	2.06	7.94	9.19
4 ¹ / ₁₆ X 2 ⁹ / ₁₆	4.06	2.56	8.50	9.31
4 ¹ / ₁₆ X 3 ¹ / ₈	4.06	3.12	8.94	9.56
4 ¹ / ₁₆ X 4 ¹ / ₁₆	4.06	4.06	10.81	10.81
5 ¹ / ₈ X 2 ¹ / ₁₆	5.12 ^a	2.06	9.06	10.56
5 ¹ / ₈ X 2 ⁹ / ₁₆	5.12 ^a	2.56	9.62	10.69
5 ¹ / ₈ X 3 ¹ / ₈	5.12 ^a	3.12	10.06	10.94
5 ¹ / ₈ X 4 ¹ / ₁₆	5.12 ^a	4.06	10.93	11.19
5 ¹ / ₈ X 5 ¹ / ₈	5.12 ^a	5.12 ^a	12.19	12.19
10,000 psi				
2 ¹ / ₁₆ X 1 ¹³ / ₁₆	2.06	1.81	6.67	6.84
2 ¹ / ₁₆ X 2 ¹ / ₁₆	2.06	2.06	6.92	6.92
2 ⁹ / ₁₆ X 1 ¹³ / ₁₆	2.56	1.81	6.95	7.47
2 ⁹ / ₁₆ X 2 ¹ / ₁₆	2.56	2.06	7.20	7.55
2 ⁹ / ₁₆ X 2 ⁹ / ₁₆	2.56	2.56	7.83	7.83
3 ¹ / ₁₆ X 1 ¹³ / ₁₆	3.06	1.81	7.23	8.22
3 ¹ / ₁₆ X 2 ¹ / ₁₆	3.06	2.06	7.48	8.30
3 ¹ / ₁₆ X 2 ⁹ / ₁₆	3.06	2.56	8.11	8.58
3 ¹ / ₁₆ X 3 ¹ / ₁₆	3.06	3.06	8.86	8.86
4 ¹ / ₁₆ X 1 ¹³ / ₁₆	4.06	1.81	7.81	9.25
4 ¹ / ₁₆ X 2 ¹ / ₁₆	4.06	2.06	8.06	9.33
4 ¹ / ₁₆ X 2 ⁹ / ₁₆	4.06	2.56	8.69	9.61
4 ¹ / ₁₆ X 3 ¹ / ₁₆	4.06	3.06	9.44	9.89
4 ¹ / ₁₆ X 4 ¹ / ₁₆	4.06	4.06	10.34	10.34
5 ¹ / ₈ X 1 ¹³ / ₁₆	5.12 ^a	1.81	8.19	10.06
5 ¹ / ₈ X 2 ¹ / ₁₆	5.12 ^a	2.06	8.44	10.12
5 ¹ / ₈ X 2 ⁹ / ₁₆	5.12 ^a	2.56	9.06	10.42
5 ¹ / ₈ X 3 ¹ / ₁₆	5.12 ^a	3.06	9.81	10.69
5 ¹ / ₈ X 4 ¹ / ₁₆	5.12 ^a	4.06	10.72	11.19
5 ¹ / ₈ X 5 ¹ / ₈	5.12 ^a	5.12 ^a	11.53	11.53
FOOTNOTE				
^a Tolerance on 5 ¹ / ₈ bore is +0.04/-0.00.				

Table E.13—Flanged Crosses and Tees (continued)

Dimensions in inches

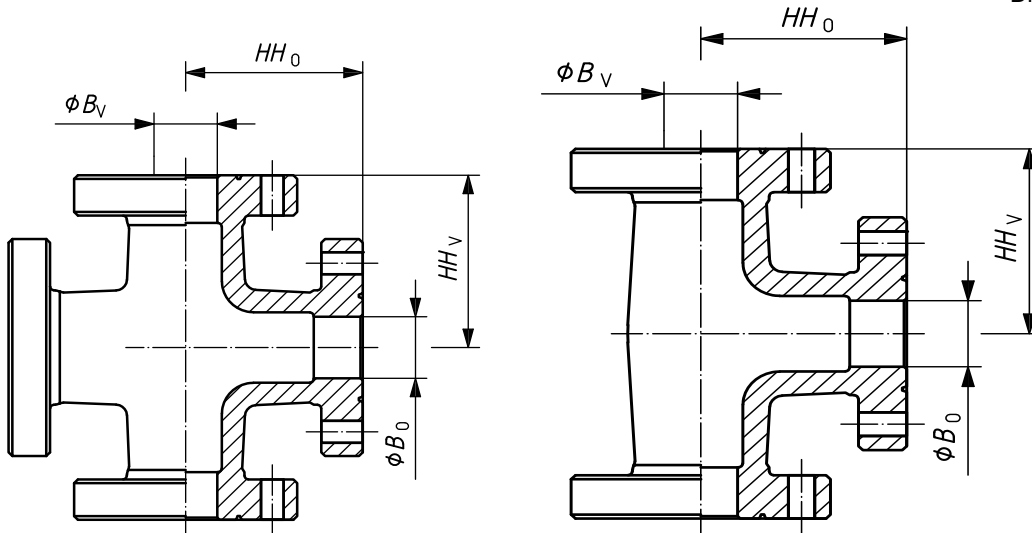

Nominal Sizes	Bore Diameter		Center-to-face Vertical Run HH_V	Center-to-face Horizontal Run HH_O
	Vertical Run B_V	Horizontal Run B_O		
Tolerance>	+0.03/-0.0	+0.03/-0.0	± 0.03	± 0.03
15,000 psi				
2 ¹ / ₁₆ X 1 ¹³ / ₁₆	2.06	1.81	7.34	7.41
2 ¹ / ₁₆ X 2 ¹ / ₁₆	2.06	2.06	7.62	7.62
2 ⁹ / ₁₆ X 1 ¹³ / ₁₆	2.56	1.81	7.59	8.03
2 ⁹ / ₁₆ X 2 ¹ / ₁₆	2.56	2.06	7.88	8.25
2 ⁹ / ₁₆ X 2 ⁹ / ₁₆	2.56	2.56	8.50	8.50
3 ¹ / ₁₆ X 1 ¹³ / ₁₆	3.06	1.81	7.86	8.69
3 ¹ / ₁₆ X 2 ¹ / ₁₆	3.06	2.06	8.16	8.91
3 ¹ / ₁₆ X 2 ⁹ / ₁₆	3.06	2.56	8.78	9.16
3 ¹ / ₁₆ X 3 ¹ / ₁₆	3.06	3.06	9.44	9.44
4 ¹ / ₁₆ X 1 ¹³ / ₁₆	4.06	1.81	8.69	10.25
4 ¹ / ₁₆ X 2 ¹ / ₁₆	4.06	2.06	8.97	10.47
4 ¹ / ₁₆ X 2 ⁹ / ₁₆	4.06	2.56	9.59	10.72
4 ¹ / ₁₆ X 3 ¹ / ₁₆	4.06	3.06	10.25	11.00
4 ¹ / ₁₆ X 4 ¹ / ₁₆	4.06	4.06	11.69	11.69
5 ¹ / ₈ X 1 ¹³ / ₁₆	5.12 ^a	1.81	9.38	11.44
5 ¹ / ₈ X 2 ¹ / ₁₆	5.12 ^a	2.06	9.63	11.63
5 ¹ / ₈ X 2 ⁹ / ₁₆	5.12 ^a	2.56	10.25	11.88
5 ¹ / ₈ X 3 ¹ / ₁₆	5.12 ^a	3.06	10.94	12.18
5 ¹ / ₈ X 4 ¹ / ₁₆	5.12 ^a	4.06	12.38	12.75
5 ¹ / ₈ X 5 ¹ / ₈	5.12 ^a	5.12 ^a	13.50	13.50
FOOTNOTE				
^a Tolerance on 5 ¹ / ₈ bore is +0.04/-0.00.				

Table E.13—Flanged Crosses and Tees (continued)

Dimensions in inches

Nominal Sizes	Bore Diameter		Center-to-face Vertical Run HH_V	Center-to-face Horizontal Run HH_O
	Vertical Run B_V	Horizontal Run B_O		
Tolerance>	+0.03/-0.0	+0.03/-0.0	± 0.03	± 0.03
20,000 psi				
$1^{13}/_{16} \times 1^{13}/_{16}$	1.81	1.81	8.94	8.94
$2^{1}/_{16} \times 1^{13}/_{16}$	2.06	1.81	9.25	9.53
$2^{1}/_{16} \times 2^{1}/_{16}$	2.06	2.06	9.84	9.84
$2^{9}/_{16} \times 1^{13}/_{16}$	2.56	1.81	9.56	10.28
$2^{9}/_{16} \times 2^{1}/_{16}$	2.56	2.06	10.16	10.59
$2^{9}/_{16} \times 2^{9}/_{16}$	2.56	2.56	10.91	10.91
$3^{1}/_{16} \times 1^{13}/_{16}$	3.06	1.81	9.94	10.91
$3^{1}/_{16} \times 2^{1}/_{16}$	3.06	2.06	10.53	10.22
$3^{1}/_{16} \times 2^{9}/_{16}$	3.06	2.56	11.28	11.53
$3^{1}/_{16} \times 3^{1}/_{16}$	3.06	3.06	11.91	11.91
$4^{1}/_{16} \times 1^{13}/_{16}$	4.06	1.81	11.12	12.66
$4^{1}/_{16} \times 2^{1}/_{16}$	4.06	2.06	11.72	12.66
$4^{1}/_{16} \times 2^{9}/_{16}$	4.06	2.56	12.47	13.28
$4^{1}/_{16} \times 3^{1}/_{16}$	4.06	3.06	13.09	13.66
$4^{1}/_{16} \times 4^{1}/_{16}$	4.06	4.06	14.84	14.84

Table E.14—Studded Crosses and Tees

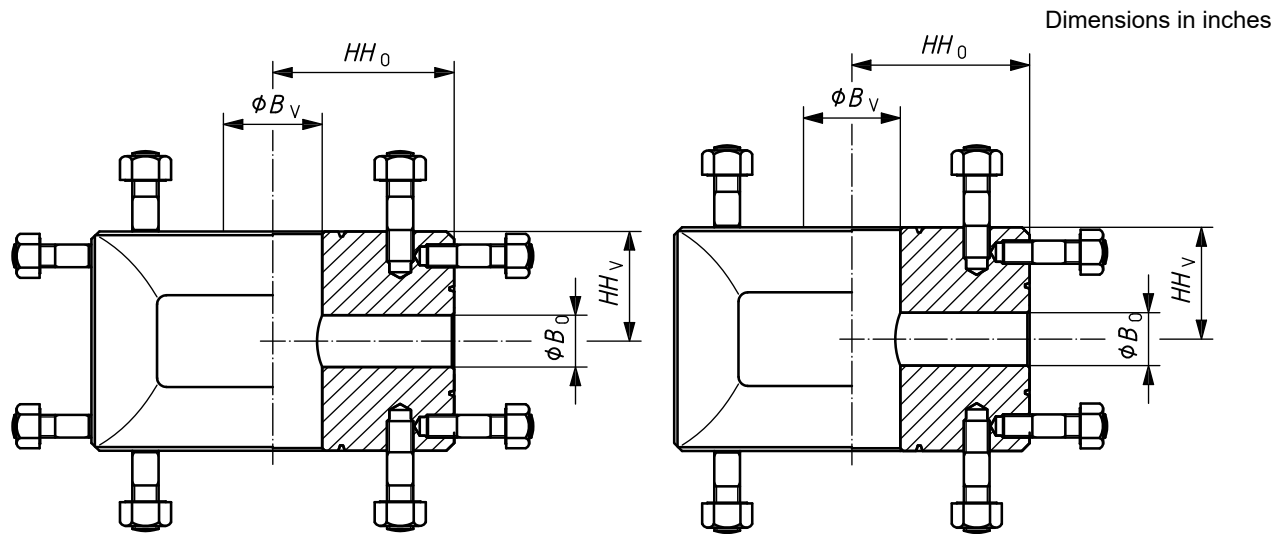

Nominal Sizes	Bore Diameter		Center-to-face Vertical Run HH_V	Center-to-face Horizontal Run HH_O
	Vertical Run B_V	Horizontal Run B_O		
Tolerance >	+0.03/-0.0	+0.03/-0.0	± 0.03	± 0.03
2000 psi				
$2^{1/16} \times 2^{1/16}$	2.06	2.06	3.50	3.50
$2^{9/16} \times 2^{1/16}$	2.56	2.06	3.50	4.00
$2^{9/16} \times 2^{9/16}$	2.56	2.56	4.50	4.50
$3^{1/8} \times 2^{1/16}$	3.12	2.06	3.50	4.50
$3^{1/8} \times 2^{9/16}$	3.12	2.56	4.50	4.50
$3^{1/8} \times 3^{1/8}$	3.12	3.12	4.50	4.50
$4^{1/16} \times 2^{1/16}$	4.06	2.06	4.50	5.50
$4^{1/16} \times 2^{9/16}$	4.06	2.56	4.50	5.50
$4^{1/16} \times 3^{1/8}$	4.06	3.12	4.50	5.50
$4^{1/16} \times 4^{1/16}$	4.06	4.06	5.50	5.50
3000 psi				
$2^{1/16} \times 2^{1/16}$	2.06	2.06	4.50	4.50
$2^{9/16} \times 2^{1/16}$	2.56	2.06	4.50	5.00
$2^{9/16} \times 2^{9/16}$	2.56	2.56	5.00	5.00
$3^{1/8} \times 2^{1/16}$	3.12	2.06	4.50	5.00
$3^{1/8} \times 2^{9/16}$	3.12	2.56	5.00	5.00
$3^{1/8} \times 3^{1/8}$	3.12	3.12	5.00	5.00
$4^{1/16} \times 2^{1/16}$	4.06	2.06	4.50	6.12
$4^{1/16} \times 2^{9/16}$	4.06	2.56	5.00	6.12
$4^{1/16} \times 3^{1/8}$	4.06	3.12	5.00	6.12
$4^{1/16} \times 4^{1/16}$	4.06	4.06	6.12	6.12

Table E.14—Studded Crosses and Tees (continued)

Dimensions in inches

Nominal Sizes	Bore Diameter		Center-to-face Vertical Run HH_V	Center-to-face Horizontal Run HH_O
	Vertical Run B_V	Horizontal Run B_O		
Tolerance>	+0.03/-0.0	+0.03/-0.0	± 0.03	± 0.03
5000 psi				
2 ¹ / ₁₆ X 2 ¹ / ₁₆	2.06	2.06	4.50	4.50
2 ⁹ / ₁₆ X 2 ¹ / ₁₆	2.56	2.06	4.50	5.00
2 ⁹ / ₁₆ X 2 ⁹ / ₁₆	2.56	2.56	5.00	5.00
3 ¹ / ₈ X 2 ¹ / ₁₆	3.12	2.06	4.50	5.50
3 ¹ / ₈ X 2 ⁹ / ₁₆	3.12	2.56	5.50	5.50
3 ¹ / ₈ X 3 ¹ / ₈	3.12	3.12	5.50	5.50
4 ¹ / ₁₆ X 2 ¹ / ₁₆	4.06	2.06	4.50	6.50
4 ¹ / ₁₆ X 2 ⁹ / ₁₆	4.06	2.56	5.00	6.50
4 ¹ / ₁₆ X 3 ¹ / ₈	4.06	3.12	5.50	6.50
4 ¹ / ₁₆ X 4 ¹ / ₁₆	4.06	4.06	6.50	6.50
5 ¹ / ₈ X 2 ¹ / ₁₆	5.12 ^a	2.06	6.12	7.62
5 ¹ / ₈ X 2 ⁹ / ₁₆	5.12 ^a	2.56	6.12	7.62
5 ¹ / ₈ X 3 ¹ / ₈	5.12 ^a	3.12	6.12	7.62
5 ¹ / ₈ X 4 ¹ / ₁₆	5.12 ^a	4.06	7.97	7.97
5 ¹ / ₈ X 5 ¹ / ₈	5.12 ^a	5.12 ^a	7.97	7.97
10,000 psi				
1 ¹³ / ₁₆ X 1 ¹³ / ₁₆	1.81	1.81	4.38	4.38
2 ¹ / ₁₆ X 1 ¹³ / ₁₆	2.06	1.81	4.38	4.38
2 ¹ / ₁₆ X 2 ¹ / ₁₆	2.06	2.06	4.38	4.38
2 ⁹ / ₁₆ X 1 ¹³ / ₁₆	2.56	1.81	4.50	5.12
2 ⁹ / ₁₆ X 2 ¹ / ₁₆	2.56	2.06	4.50	5.12
2 ⁹ / ₁₆ X 2 ⁹ / ₁₆	2.56	2.56	5.12	5.12
3 ¹ / ₁₆ X 1 ¹³ / ₁₆	3.06	1.81	4.50	5.88
3 ¹ / ₁₆ X 2 ¹ / ₁₆	3.06	2.06	4.50	5.88
3 ¹ / ₁₆ X 2 ⁹ / ₁₆	3.06	2.56	5.12	5.88
3 ¹ / ₁₆ X 3 ¹ / ₁₆	3.06	3.06	5.88	5.88
4 ¹ / ₁₆ X 1 ¹³ / ₁₆	4.06	1.81	4.50	6.88
4 ¹ / ₁₆ X 2 ¹ / ₁₆	4.06	2.06	4.50	6.88
4 ¹ / ₁₆ X 2 ⁹ / ₁₆	4.06	2.56	5.12	6.88
4 ¹ / ₁₆ X 3 ¹ / ₁₆	4.06	3.06	5.88	6.88
4 ¹ / ₁₆ X 4 ¹ / ₁₆	4.06	4.06	6.88	6.88
5 ¹ / ₈ X 1 ¹³ / ₁₆	5.12 ^a	1.81	5.25	7.75
5 ¹ / ₈ X 2 ¹ / ₁₆	5.12 ^a	2.06	5.25	7.75
5 ¹ / ₈ X 2 ⁹ / ₁₆	5.12 ^a	2.56	5.25	7.75
5 ¹ / ₈ X 3 ¹ / ₁₆	5.12 ^a	3.06	6.75	7.75
5 ¹ / ₈ X 4 ¹ / ₁₆	5.12 ^a	4.06	6.75	7.75
5 ¹ / ₈ X 5 ¹ / ₈	5.12 ^a	5.12 ^a	7.75	7.75
FOOTNOTE				
^a Tolerance on 5 ¹ / ₈ bore is +0.04/-0.00.				

Table E.14—Studded Crosses and Tees (continued)

Dimensions in inches

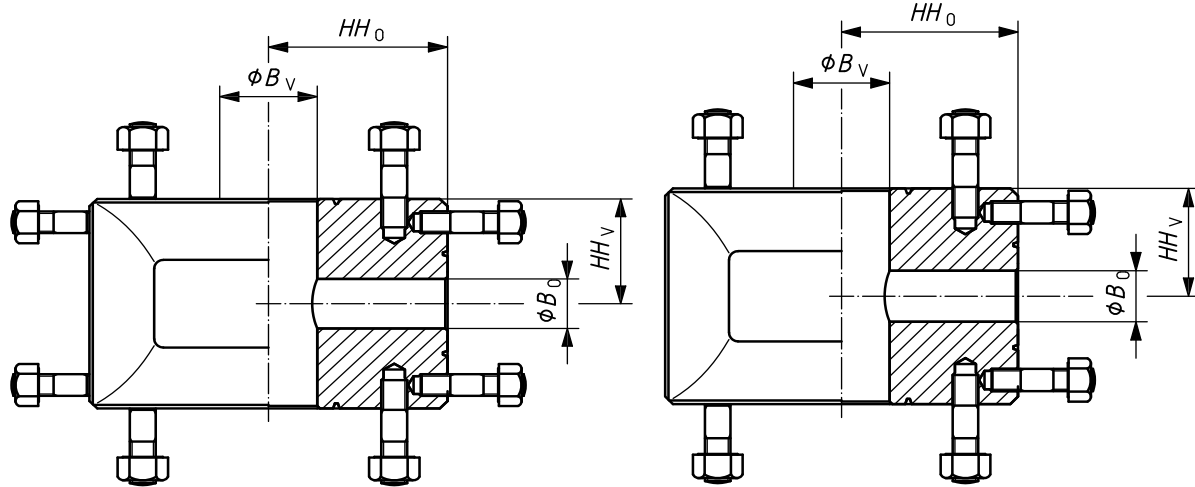

Nominal Sizes	Bore Diameter		Center-to-face Vertical Run HH_V	Center-to-face Horizontal Run HH_0
	Vertical Run B_V	Horizontal Run B_0		
Tolerance>	+0.03/-0.0	+0.03/-0.0	± 0.03	± 0.03
15,000 psi				
1 ¹³ / ₁₆ X 1 ¹³ / ₁₆	1.81	1.81	5.00	5.00
2 ¹ / ₁₆ X 1 ¹³ / ₁₆	2.06	1.81	5.00	5.00
2 ¹ / ₁₆ X 2 ¹ / ₁₆	2.06	2.06	5.00	5.00
2 ⁹ / ₁₆ X 1 ¹³ / ₁₆	2.56	1.81	5.50	5.50
2 ⁹ / ₁₆ X 2 ¹ / ₁₆	2.56	2.06	5.50	5.50
2 ⁹ / ₁₆ X 2 ⁹ / ₁₆	2.56	2.56	5.50	5.50
3 ¹ / ₁₆ X 1 ¹³ / ₁₆	3.06	1.81	6.31	6.31
3 ¹ / ₁₆ X 2 ¹ / ₁₆	3.06	2.06	6.31	6.31
3 ¹ / ₁₆ X 2 ⁹ / ₁₆	3.06	2.56	6.31	6.31
3 ¹ / ₁₆ X 3 ¹ / ₁₆	3.06	3.06	6.31	6.31
4 ¹ / ₁₆ X 1 ¹³ / ₁₆	4.06	1.81	7.62	7.62
4 ¹ / ₁₆ X 2 ¹ / ₁₆	4.06	2.06	7.62	7.62
4 ¹ / ₁₆ X 2 ⁹ / ₁₆	4.06	2.56	7.62	7.62
4 ¹ / ₁₆ X 3 ¹ / ₁₆	4.06	3.06	7.62	7.62
4 ¹ / ₁₆ X 4 ¹ / ₁₆	4.06	4.06	7.62	7.62
5 ¹ / ₈ X 1 ¹³ / ₁₆	5.12 ^a	1.81	6.62	8.75
5 ¹ / ₈ X 2 ¹ / ₁₆	5.12 ^a	2.06	6.62	8.75
5 ¹ / ₈ X 2 ⁹ / ₁₆	5.12 ^a	2.56	6.62	8.75
5 ¹ / ₈ X 3 ¹ / ₁₆	5.12 ^a	3.06	6.62	8.75
5 ¹ / ₈ X 4 ¹ / ₁₆	5.12 ^a	4.06	9.25	9.25
5 ¹ / ₈ X 5 ¹ / ₈	5.12 ^a	5.12 ^a	9.25	9.25
FOOTNOTE				
^a Tolerance on 5 ¹ / ₈ bore is +0.04/-0.00.				

Table E.14—Studded Crosses and Tees (continued)

Dimensions in inches

Nominal Sizes	Bore Diameter		Center-to-face Vertical Run HH_V	Center-to-face Horizontal Run HH_O
	Vertical Run B_V	Horizontal Run B_O		
Tolerance>	+0.03/-0.0	+0.03/-0.0	± 0.03	± 0.03
20,000 psi				
1 ¹³ / ₁₆ X 1 ¹³ / ₁₆	1.81	1.81	6.47	6.47
2 ¹ / ₁₆ X 1 ¹³ / ₁₆	2.06	1.81	6.47	6.47
2 ¹ / ₁₆ X 2 ¹ / ₁₆	2.06	2.06	6.47	6.47
2 ⁹ / ₁₆ X 1 ¹³ / ₁₆	2.56	1.81	7.28	7.28
2 ⁹ / ₁₆ X 2 ¹ / ₁₆	2.56	2.06	7.28	7.28
2 ⁹ / ₁₆ X 2 ⁹ / ₁₆	2.56	2.56	7.28	7.28
3 ¹ / ₁₆ X 1 ¹³ / ₁₆	3.06	1.81	7.97	7.97
3 ¹ / ₁₆ X 2 ¹ / ₁₆	3.06	2.06	7.97	7.97
3 ¹ / ₁₆ X 2 ⁹ / ₁₆	3.06	2.56	7.97	7.97
3 ¹ / ₁₆ X 3 ¹ / ₁₆	3.06	3.06	7.97	7.97
4 ¹ / ₁₆ X 1 ¹³ / ₁₆	4.06	1.81	9.91	9.91
4 ¹ / ₁₆ X 2 ¹ / ₁₆	4.06	2.06	9.91	9.91
4 ¹ / ₁₆ X 2 ⁹ / ₁₆	4.06	2.56	9.91	9.91
4 ¹ / ₁₆ X 3 ¹ / ₁₆	4.06	3.06	9.91	9.91
4 ¹ / ₁₆ X 4 ¹ / ₁₆	4.06	4.06	9.91	9.91

Table E.15—Bullplugs

Dimensions in inches

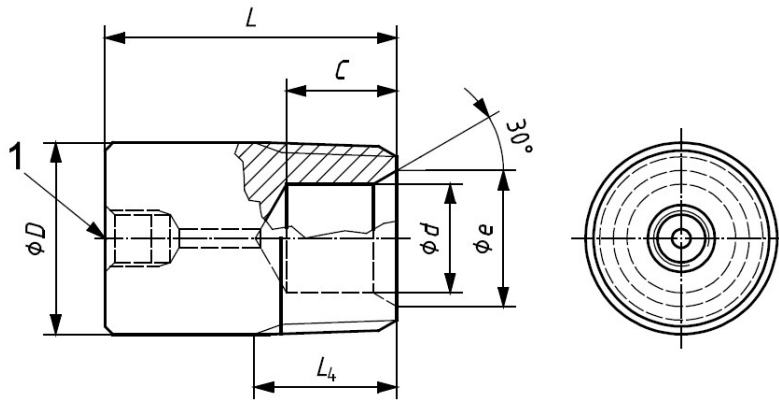

a) Round plug

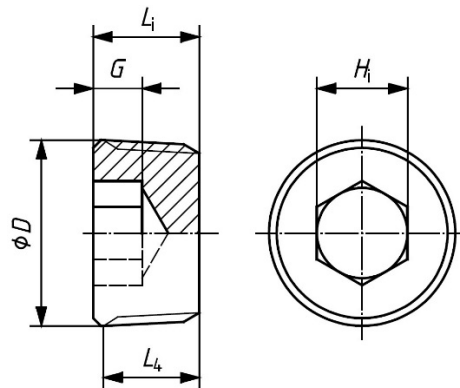

b) Plug with internal hex

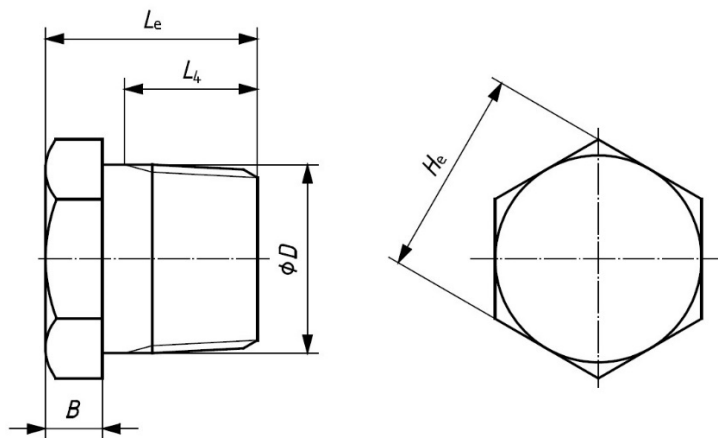

c) Plug with external hex

Key

1 test or gauge port (optional)

NOTE See API 5B for thread dimensions and tolerances.

Table E.15—Bullplugs (continued)

Dimensions in inches

		a), b), c) All Styles of Bullplugs					a) Round Plugs
Nominal Size	Outside Diameter		Minimum Length of Thread to Vanish Point	Depth of Counterbore	Diameter of Counterbore	Diameter of Chamfer	Overall Length
in.	<i>D</i>		<i>L₄</i>	<i>C</i>	<i>d</i>	<i>e</i>	<i>L</i>
Tolerance>	Value	Tolerance	Minimum	± 0.02	+0.04/-0	+0.02/-0	+0.04/-0
1/2	0.840	+0.008/-0	0.7815	None	None	None	2.00
3/4	1.050	+0.008/-0	0.7935	None	None	None	2.00
1	1.320	+0.010/-0	0.9845	None	None	None	2.00
1 1/4	1.660	+0.010/-0	1.0085	1.06	0.88	None	2.00
1 1/2	1.900	+0.010/-0	1.0252	1.06	1.00	None	2.00
2	2.380	+0.010/-0	1.0582	2.52	1.61	2.00	4.00
2 1/2	2.880	+0.010/-0	1.5712	1.63	1.75	None	4.00
3	3.500	+0.010/-0	1.6337	1.63	2.25	None	4.00
3 1/2	4.000	+0.010/-0	1.6837	1.75	2.75	None	4.00
4	4.500	+0.010/-0	1.7337	1.75	3.00	None	4.00

		b) Plugs with Internal Hex			c) Plugs with External Hex			
Nominal Size	Hex Size (Across Flats)		Depth of Hex	Overall Length	Hex Size (Across Flats)		Height of Hex	Overall Length
in.	<i>H_i</i>		<i>G</i>	<i>L_i</i>	<i>H_e</i>		<i>B</i>	<i>L_e</i>
Tolerance>	Value	Tolerance	+0.04/-0	+0.04/-0	Value	Tolerance	+0.04/-0	+0.04/-0
1/2	0.38	+0/-0.004	0.31	1.00	0.88	+0/-0.025	0.31	1.13
3/4	0.56	+0/-0.005	0.31	1.00	1.06	+0/-0.031	0.38	1.25
1	0.63	+0/-0.006	0.38	1.00	1.38	+0/-0.041	0.38	1.38

Table E.16—VR Plug Dimensions, 2000 psi, 3000 psi, 5000 psi, and 10,000 psi

Dimensions in inches; surface roughness in microinches

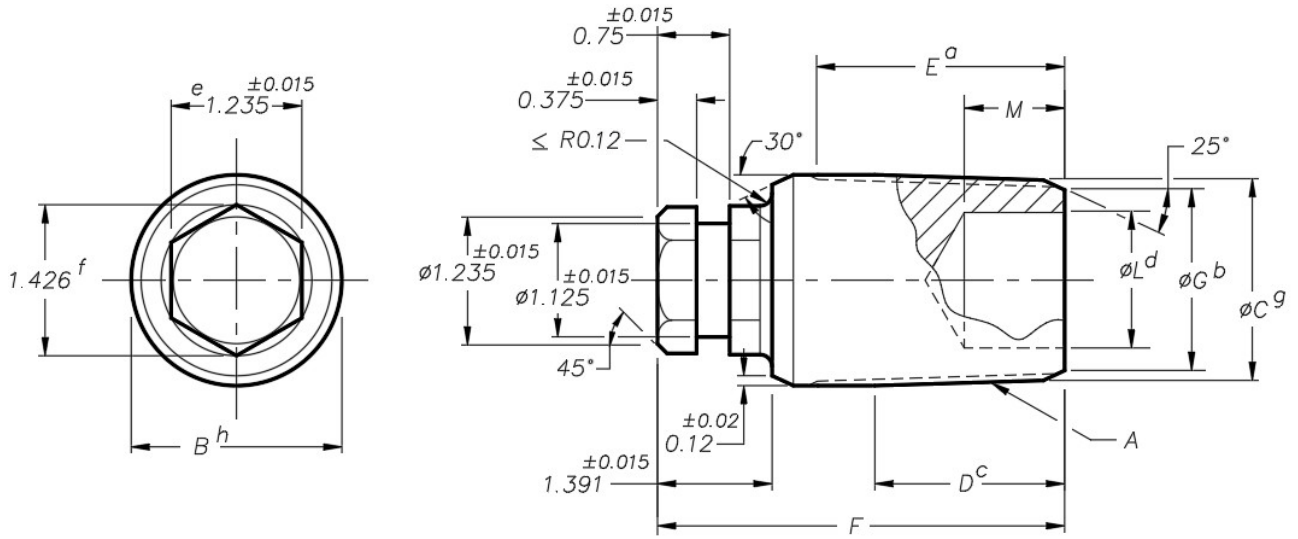

FOOTNOTES

- a Full thread.
- b Chamfer at end.
- c End of taper.
- d Drill L, M deep.
- e Across flats.
- f Across corners.
- g Diameter at face.
- h Equal to nominal diameter A.

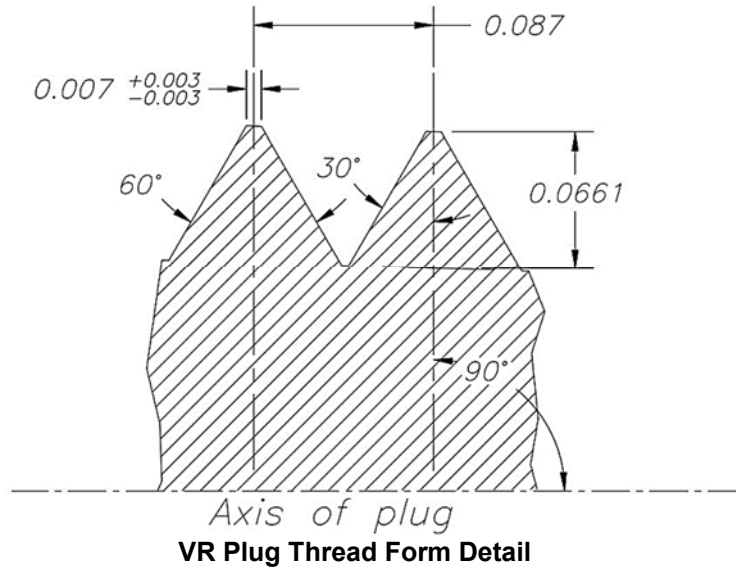

Table E.16—VR Plug Dimensions, 2000 psi, 3000 psi, 5000 psi, and 10,000 psi (continued)

Dimensions in inches

Nominal Outlet Size	Nominal Thread OD A	Threads per Inch TPI	Thread Type	Diameter at Large End B	Diameter at Small End C	Length of Taper D	Length of Full Thread E	Overall Length of Plug F	Chamfer Diameter G	Counter-bore Diameter L	Counter-bore Depth M
Tolerance>		(Ref.)	NA	± 0.005	± 0.005	(Ref.)	(Ref.)	± 0.03	± 0.015	± 0.015	± 0.03
1 ¹³ / ₁₆	1.660	11 ¹ / ₂	Line pipe	1.660	1.620	0.640	1.009	2.84	1.488	0.88	1.06
2 ¹ / ₁₆	1.900	11 ¹ / ₂	Sharp vee	1.900	1.834	1.051	1.375	3.16	1.702	1.00	1.06
2 ⁹ / ₁₆	2 ³ / ₈	11 ¹ / ₂	Sharp vee	2.375	2.294	1.301	1.625	3.41	2.162	1.50	1.06
3 ¹ / ₈	2 ⁷ / ₈	11 ¹ / ₂	Sharp vee	2.875	2.766	1.739	2.063	3.84	2.634	1.75	1.63
4 ¹ / ₁₆	3 ¹ / ₂	11 ¹ / ₂	Sharp vee	3.500	3.376	1.989	2.313	4.09	3.244	2.75	1.75
FOOTNOTES											
^a 3 ¹ / ₁₆ in. bore for 10,000 psi RWP. NOTE 1 Thread taper for all sizes shall be 1-in-16 (reference 1° 47' 24" with the centerline). NOTE 2 Tolerances on angles, unless otherwise noted, are ± 0.5 degrees.											

Table E.17—VR Preparation Dimensions, 2000 psi, 3000 psi, 5000 psi, and 10,000 psi

Dimensions in inches; surface roughness in microinches

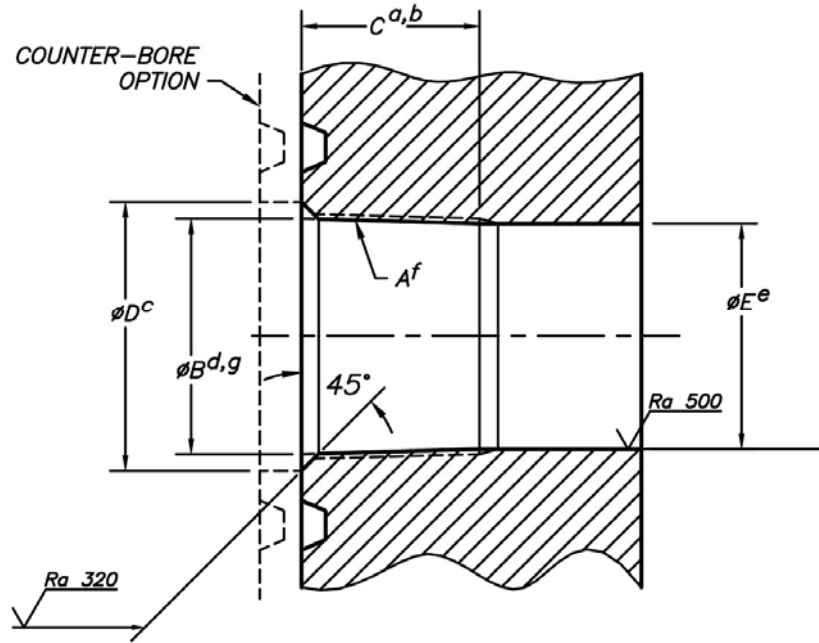

FOOTNOTES

- a Full thread.
- b Reference.
- c Diameter of counterbore or chamfer.
- d Thread bore.
- e Standard bore.
- f Thread.
- 9 Thread bore taken at face of flange, gauge thread from bottom of chamfer, counterbore is optional.

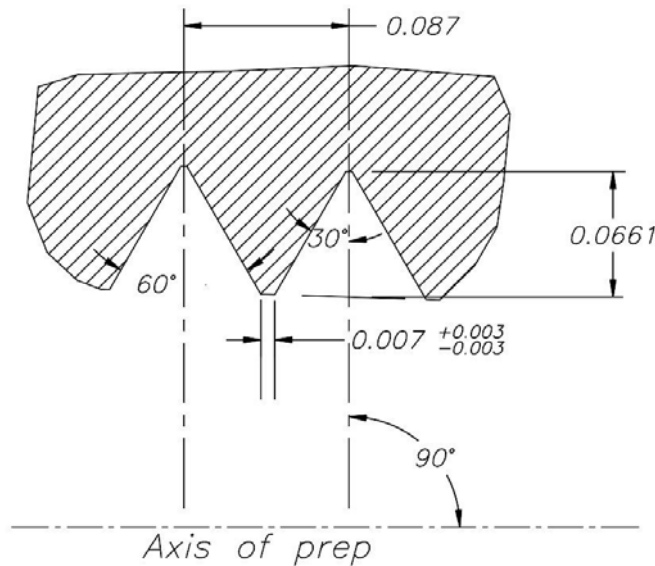

VR Preparation Thread Form Detail

Table E.17—VR Preparation Dimensions, 2000 psi, 3000 psi, 5000 psi, and 10,000 psi (continued)

Dimensions in inches

Nominal Outlet Size	Nominal Thread OD	Threads per Inch	Thread Type	Thread Bore	Full Thread Length	Chamfer and Counterbore Diameter	Straight Bore
	<i>A</i>	TPI		<i>B</i>	<i>C</i>	<i>D</i>	<i>E</i>
Tolerance>		(Ref.)	NA	± 0.005	(Ref.)	± 0.03	± 0.015
1 ¹³ / ₁₆	1.660	11 ¹ / ₂	Line pipe	1.532	1.08	1.94	1.449
2 ¹ / ₁₆	1.900	11 ¹ / ₂	Sharp vee	1.771	1.51	2.19	1.662
2 ⁹ / ₁₆	2 ³ / ₈	11 ¹ / ₂	Sharp vee	2.242	1.76	2.56	2.117
3 ¹ / ₈ ^a	2 ⁷ / ₈	11 ¹ / ₂	Sharp vee	2.740	2.20	3.06	2.588
4 ¹ / ₁₆	3 ¹ / ₂	11 ¹ / ₂	Sharp vee	3.377	2.45	4.06	3.209
FOOTNOTES ^a 3 ¹ / ₁₆ in. bore for 10,000 psi RWP. Thread taper for all sizes shall be 1-in-16 (reference 1° 47' 24" with the centerline).							

Table E.18—VR Plug Thread Gauging Dimensions, 2000 psi, 3000 psi, 5000 psi, and 10,000 psi

Dimensions in inches

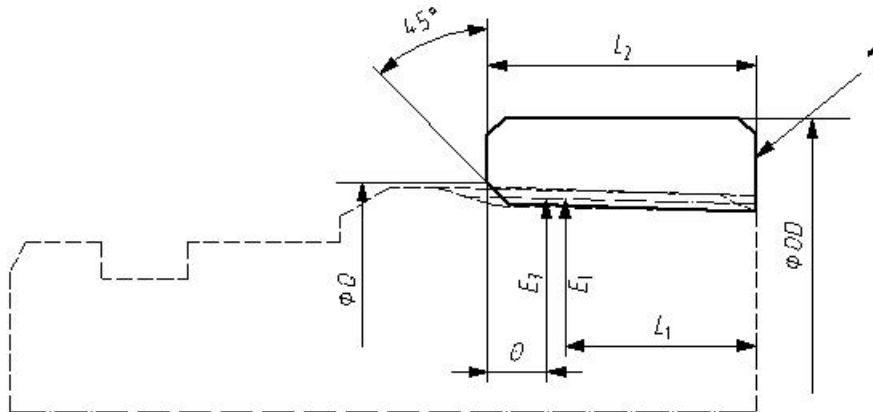
**Key**1 gauge standoff with end of VR plug: flush $\pm 1p$

NOTE "p" is defined as the distance from a point on a nominal thread form to a corresponding point on the next thread, measured parallel to the axis. This value can be calculated by dividing 1 mm by the number of threads per millimeter.

Nominal Size	Ring Gauge Outside Diameter <i>OD</i>	Ring Gauge Chamfer Diameter <i>Q</i>	Ring Gauge Length <i>L₂</i>	Face of Ring Gauge to Plane of Gauge Point <i>θ</i>
1 ¹³ / ₁₆	2.20	1.72	0.7068	0.1739
2 ¹ / ₁₆	2.50	1.96	1.1385	0.1983
2 ⁹ / ₁₆	3.06	2.44	1.3885	0.1983
3 ¹ / ₈ ^a	3.67	2.94	1.8260	0.1983
4 ¹ / ₁₆	4.50	3.56	2.0760	0.1983

FOOTNOTES

^a 3¹/₁₆ in. bore for 10,000 psi RWP.

NOTE 1 See Table E.18 for location of dimensions.

NOTE 2 See Table E.19 for *E₇*, *E₁*, and *L₁*.

Table E.19—VR Preparation Thread Gauging Dimensions, 2000 psi, 3000 psi, 5000 psi, and 10,000 psi

Dimensions in inches

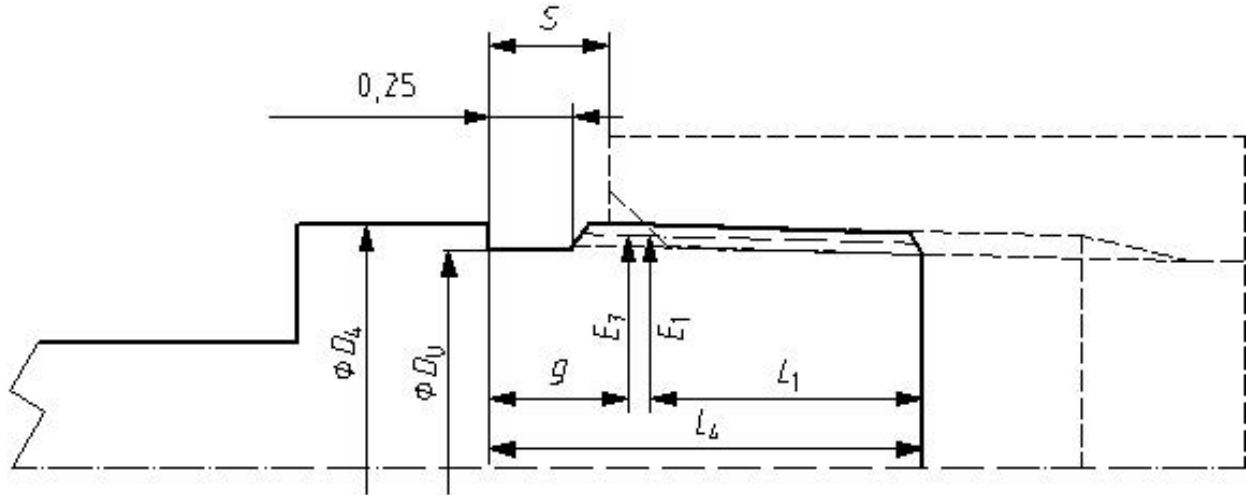

Nominal Outlet Size	Major Diameter	Diameter of Plug Gauge Groove	Threads per Inch	Length: End of Pipe to Hand-tight Plane	Pitch Diameter at Hand-tight Plane	Total Length: End of Pipe to Vanish Point	Length: Gauge Point to Vanish Point	Pitch Diameter at Gauge Point	Standoff
	D_4	D_0		L_1	E_1	L_4	g	E_7	S ± 0.087
1 ¹³ / ₁₆	1.660	1.46	11 ¹ / ₂	0.4200	1.58338	1.0085	0.4756	1.59043	0.4102
2 ¹ / ₁₆	1.900	1.70	11 ¹ / ₂	0.8106	1.82234	1.3750	0.4348	1.83043	0.3806
2 ⁹ / ₁₆	2.375	2.18	11 ¹ / ₂	1.0436	2.29628	1.6250	0.4348	2.30543	0.4495
3 ¹ / ₈ ^a	2.875	2.68	11 ¹ / ₂	1.4538	2.79457	2.0625	0.4348	2.80543	0.4760
4 ¹ / ₁₆	3.500	3.30	11 ¹ / ₂	1.7038	3.41957	2.3125	0.4348	3.43043	0.2885

FOOTNOTE

^a 3¹/₁₆ in. bore for 10,000 psi RWP.

Table E.20—HPVR Plug Dimensions, 15,000 psi and 20,000 psi

Dimensions in inches; surface roughness in microinches

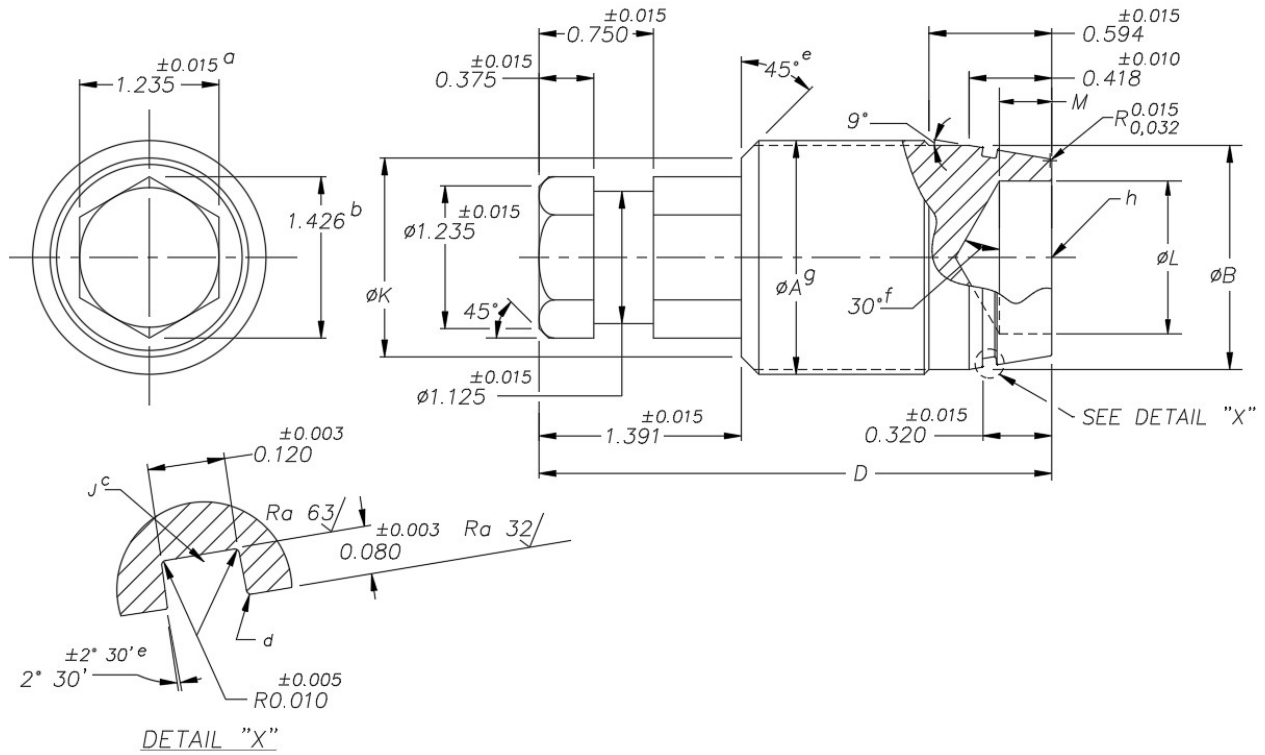

FOOTNOTES

- a Across flats.
- b Across corners.
- c Install (SAE AS568A O-ring size number).
- d Break corners approx. $R 0.005$.
- e Typical.
- f Optional.
- g Thread.
- h Drill L diameter, M deep.

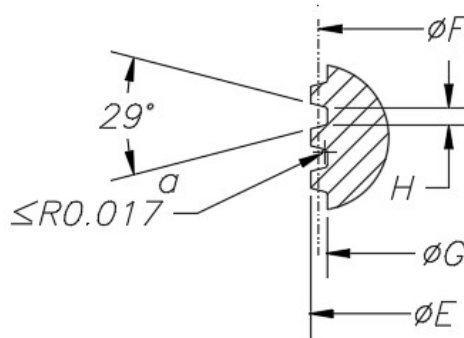

Thread Form Detail

FOOTNOTE

- a Typical for all full threads.

Table E.20—HPVR Plug Dimensions, 15,000 psi and 20,000 psi (continued)

Dimensions in inches

Nominal Outlet Size in.	Nominal Thread Size in.	Threads per Inch	Large Taper Diameter	Overall Length	SAE AS568A O-ring Size No.	Chamfer Diameter	Counterbore Diameter	Counterbore Depth
	<i>A</i>	TPI	<i>B</i>	<i>D</i>	<i>J</i>	<i>K</i>	<i>L</i>	<i>M</i>
Tolerance>		(Ref.)	± 0.010	± 0.03	NA	± 0.03	± 0.015	± 0.015
1 ¹³ / ₁₆	1 ³ / ₄	6	1.600	3.75	126	1.50	NA	NA
2 ¹ / ₁₆	2	6	1.850	3.75	130	1.75	NA	NA
2 ⁹ / ₁₆	2 ¹ / ₂	6	2.349	4.19	138	2.33	0.938	0.625
3 ¹ / ₁₆	3	6	2.849	4.19	146	2.84	1.125	0.625

Nominal Outlet Size in.	Nominal Thread Size in.	Threads per Inch	Thread Major Diameter	Thread Pitch Diameter	Thread Minor Diameter	Width of Thread at Root
	<i>A</i>	TPI	<i>E</i>	<i>F</i>	<i>G</i>	<i>H</i>
Tolerance>		(Ref.)	± 0.004	± 0.010	± 0.010	(Ref.)
1 ¹³ / ₁₆	1 ³ / ₄	6	1.746	1.679	1.620	0.068
2 ¹ / ₁₆	2	6	1.996	1.928	1.869	0.068
2 ⁹ / ₁₆	2 ¹ / ₂	6	2.496	2.427	2.369	0.068
3 ¹ / ₁₆	3	6	2.996	2.925	2.869	0.068

Table E.21—HPVR Preparation Dimensions, 15,000 psi and 20,000 psi

Dimensions in inches; surface roughness in inches

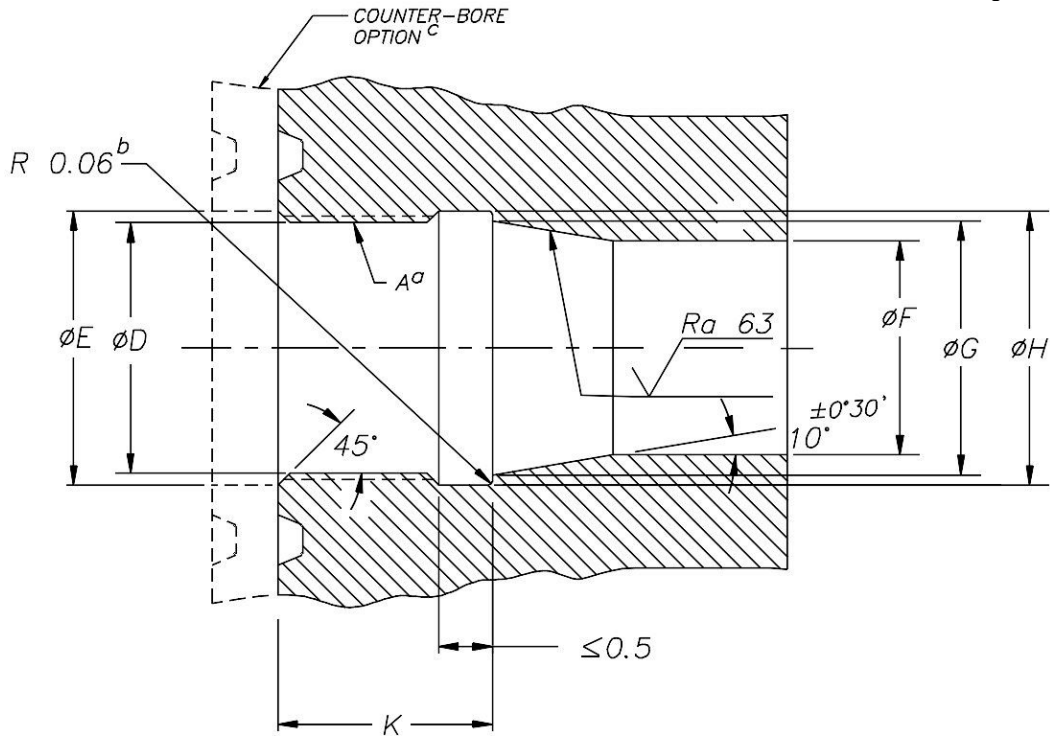

FOOTNOTES

- a Thread.
- b Typical two places.
- c Optional counterbore (0.50 in. deep) max.

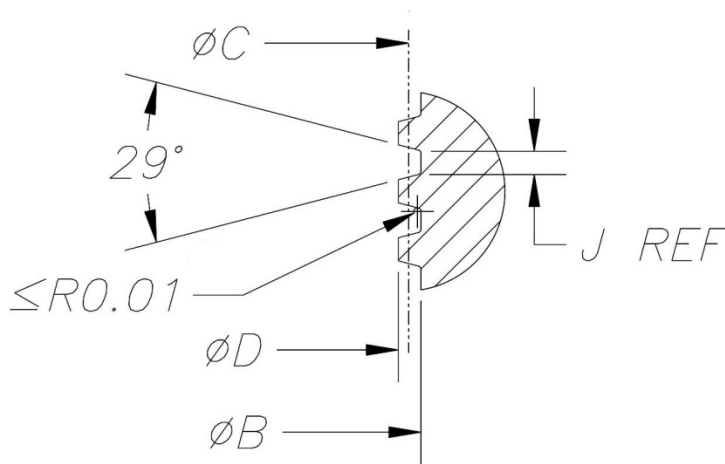

Thread Form Detail

- NOTE 1 Features and dimensions are typical for all full threads.
- NOTE 2 Tolerances on angles, unless otherwise noted, shall be ± 0.5 degrees.
- NOTE 3 All diameters shall be concentric within 0.005 in. total indicator reading.

Table E.21—HPVR Preparation Dimensions, 15,000 psi and 20,000 psi (continued)

Dimensions in inches

Nominal Outlet Size	Chamfer and Counterbore Diameter	Straight Through Bore	Large Diameter of Taper	Thread Relief Diameter	Depth to Taper
	<i>E</i>	<i>F</i>	<i>G</i>	<i>H</i>	<i>K</i>
Tolerance>	± 0.015	± 0.005	± 0.005	± 0.015	± 0.015
1 ¹³ / ₁₆	1.825	1.475	1.625	1.820	1.563
2 ¹ / ₁₆	2.075	1.725	1.875	2.086	1.563
2 ⁹ / ₁₆	2.625	2.224	2.375	2.585	2.092
3 ¹ / ₁₆	3.075	2.725	2.875	3.080	2.092

Nominal Outlet Size	Nominal Thread Size in. <i>A</i>	Threads per Inch TPI	Stub Acme Class 2G Thread Form Dimensions			
			Thread Major Diameter <i>B</i>	Thread Pitch Diameter <i>C</i>	Thread Minor Diameter <i>D</i>	Width of Thread at Root <i>J</i>
Tolerance>		(Ref.)	± 0.010	± 0.010	± 0.004	(Ref.)
1 ¹³ / ₁₆	1 ³ / ₄	6	1.780	1.710	1.654	0.065
2 ¹ / ₁₆	2	6	2.030	1.960	1.904	0.065
2 ⁹ / ₁₆	2 ¹ / ₂	6	2.531	2.461	2.404	0.065
3 ¹ / ₁₆	3	6	3.031	2.961	2.904	0.065

Table E.22—Flanged Full-bore Gate Valves

Dimensions in inches

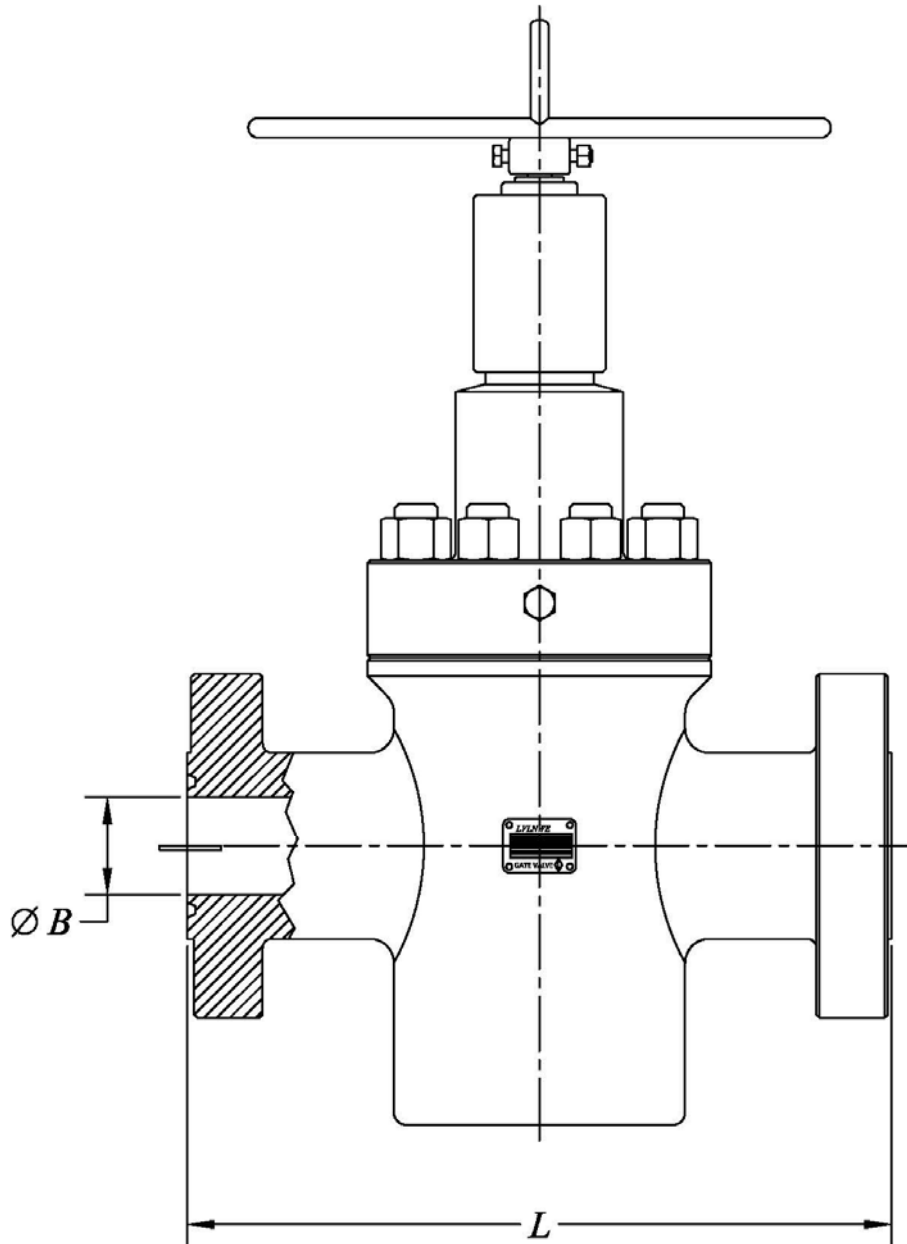

Table E.22—Flanged Full-bore Gate Valves (continued)

Dimensions in inches

Nominal Size in.	Bore	<i>L</i> , Face-to-face Length, in.					
	<i>B</i>	2000 psi	3000 psi	5000 psi	10,000 psi	15,000 psi	20,000 psi
Tolerance>	+0.03/-0	± 0.06	± 0.06	± 0.06	± 0.06	± 0.06	± 0.06
1 ¹³ / ₁₆	1.81	—	—	—	18.25	18.00	21.00
2 ¹ / ₁₆ X 1 ¹³ / ₁₆	1.81	11.62	14.62	14.62	—	—	—
2 ¹ / ₁₆	2.06	11.62	14.62	14.62	20.50	19.00	23.00
2 ⁹ / ₁₆	2.56	13.12	16.62	16.62	22.25	21.00	26.50
3 ¹ / ₁₆	3.06	—	—	—	24.38	23.56	30.50
3 ¹ / ₈	3.12	14.12	17.12	18.62	—	—	—
3 ¹ / ₈ X 3 ³ / ₁₆	3.19	14.12	17.12	18.62	—	—	—
4 ¹ / ₁₆	4.06	17.12	20.12	21.62	26.38	29.00	38.00
4 ¹ / ₁₆ X 4 ¹ / ₈	4.12	17.12	20.12	21.62	—	—	—
4 ¹ / ₁₆ X 4 ¹ / ₄	4.25	17.12	20.12	21.62	—	—	—
5 ¹ / ₈ ^a	5.12 ^a	22.12	24.12	28.62	29.00	35.00	—
7 ¹ / ₁₆ X 5 ¹ / ₈	5.12 ^a	—	—	29.00	—	—	—
7 ¹ / ₁₆ X 6	6.00	22.12	24.12	29.00	—	—	—
7 ¹ / ₁₆ X 6 ¹ / ₈	6.12	—	—	29.00	—	—	—
7 ¹ / ₁₆ X 6 ³ / ₈	6.38	22.12	24.12	29.00	35.00	41.00	PMR
7 ¹ / ₁₆ X 6 ⁵ / ₈	6.62	22.12	24.12	29.00	—	—	—
7 ¹ / ₁₆	7.06	26.12	28.12	32.00	35.00	41.00	PMR
7 ¹ / ₁₆ X 7 ¹ / ₈	7.12	26.12	28.12	32.00	—	—	—
9	9.00	—	—	41.00	PMR	—	—
11	11.00	—	—	PMR	—	—	—

FOOTNOTE

^a Bore tolerance for 5¹/₈ in. size is +0.04/-0.

Table E.23—Flanged Plug Valves and Ball Valves

Dimensions in inches

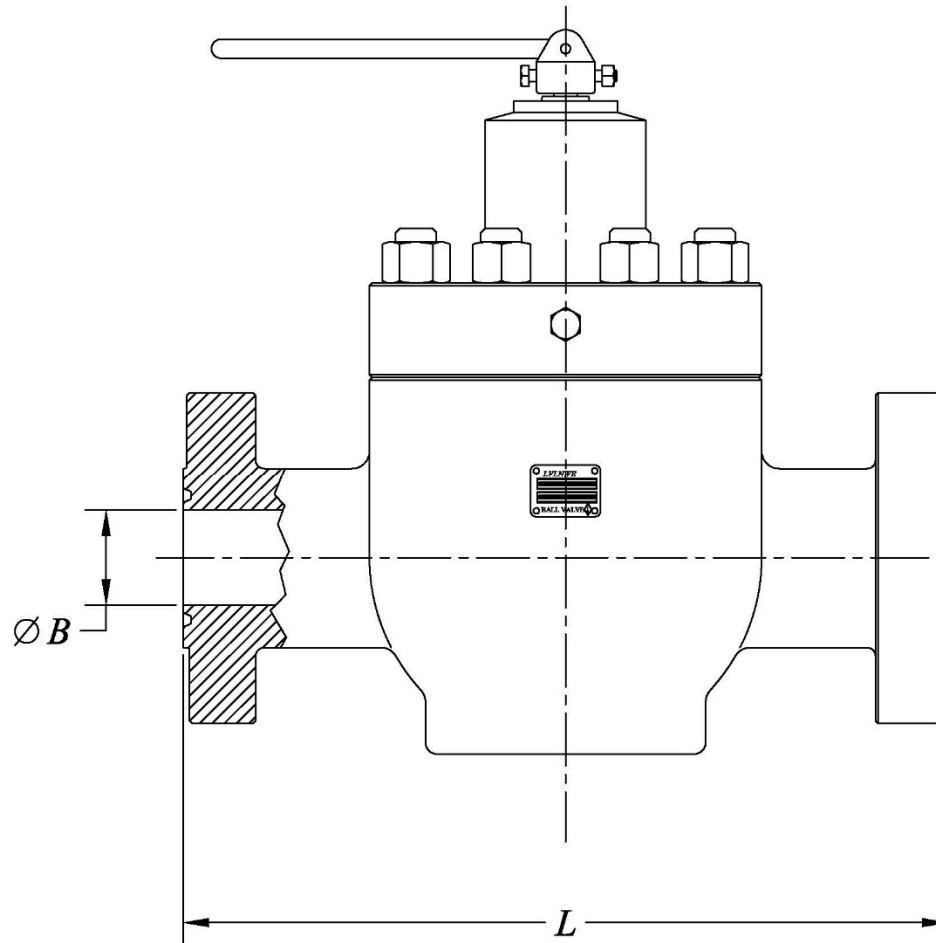

Table E.23—Flanged Plug Valves and Ball Valves (continued)

Dimensions in inches

a) Flanged Full-bore Plug Valves							
Nominal Size in.	Bore	L, Face-to-face Length					
	B	2000 psi	3000 psi	5000 psi	10,000 psi	15,000 psi	20,000 psi
Tolerance>	+0.03/-0	± 0.06	± 0.06	± 0.06	± 0.06	± 0.06	± 0.06
1 ¹³ / ₁₆	1.81	—	—	—	18.25	18.00	21.00
2 ¹ / ₁₆	2.06	13.12	15.12	15.50	20.50	19.00	23.00
2 ⁹ / ₁₆	2.56	15.12	17.12	18.00	22.25	21.00	26.50
3 ¹ / ₁₆	3.06	—	—	—	24.38	23.56	30.50
3 ¹ / ₈	3.12	17.62	18.62	20.75	—	—	—
3 ¹ / ₈ x 3 ³ / ₁₆	3.19	17.62	18.62	20.75	—	—	—
4 ¹ / ₁₆	4.06	20.12	22.12	24.75	26.38	29.00	38.00
4 ¹ / ₁₆ x 4 ¹ / ₈	4.12	20.12	22.12	24.75	—	—	—
4 ¹ / ₁₆ x 4 ¹ / ₄	4.25	20.12	22.12	24.75	—	—	—
5 ¹ / ₈	5.12 ^b	25.12	26.12	—	29.00	35.00	—
7 ¹ / ₁₆ x 6	6.00	28.62	30.12	—	—	—	—
7 ¹ / ₁₆ x 6 ³ / ₈	6.38	—	—	—	35.00	41.00	PMR
7 ¹ / ₁₆	7.06	29.12	31.62	38.50	35.00	41.00	PMR
7 ¹ / ₁₆ x 7 ¹ / ₈	7.12	29.12	31.62	38.50	—	—	—
9	—	—	—	—	PMR	—	—
b) Flanged Full-bore and Reduced-opening Ball Valves							
Nominal Size in.	Bore	L, Face-to-face Length					
	B	2000 psi	3000 psi	5000 psi	10,000 psi	15,000 psi ^a	20,000 psi ^a
Tolerance>	+0.03/-0	± 0.06	± 0.06	± 0.06	± 0.06	± 0.06	± 0.06
1 ¹³ / ₁₆	1.81	—	—	—	18.25	18.00	21.00
2 ¹ / ₁₆	2.06	11.62	14.62	14.62	20.50	19.00	23.00
2 ⁹ / ₁₆	2.56	13.12	16.62	18.62	22.25	21.00	26.50
3 ¹ / ₁₆	3.06	—	—	—	24.38	23.56	30.50
3 ¹ / ₈	3.12	14.12	15.12	18.62	—	—	—
4 ¹ / ₁₆	4.06	17.12	18.12	21.62	26.38	29.00	—
5 ¹ / ₈	5.12 ^b	—	—	—	29.00	35.00	—
7 ¹ / ₁₆ x 6	6.00	22.12	24.12	29.00	—	—	—
7 ¹ / ₁₆ x 6 ³ / ₈	6.38	—	—	—	35.00	41.00	—
7 ¹ / ₁₆	7.06	—	—	—	35.00	41.00	PMR
9	9.00	—	—	—	PMR	—	—
FOOTNOTE							
^a Applies to full bore only.							
^b Bore tolerance for 5 ¹ / ₈ in. size is +0.04/-0.							

Table E.24—Flanged Swing and Lift Check Valves

Dimensions in inches

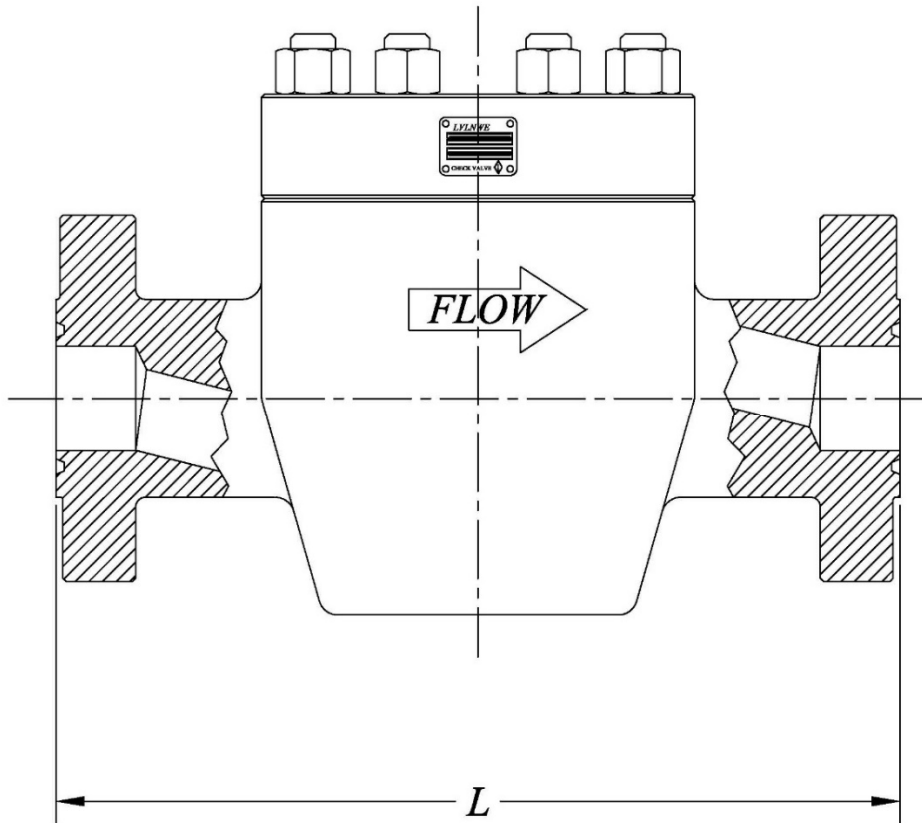

a) Minimum Bore Sizes for Full-opening Check Valves, 2000 psi, 3000 psi, and 5000 psi			
Nominal Size in.	Minimum Bore Size		
	2000 psi	3000 psi	5000 psi
Tolerance>	+0.06/-0	+0.06/-0	+0.06/-0
2 ¹ / ₁₆	2.067	1.939	1.689
2 ⁹ / ₁₆	2.469	2.323	2.125
3 ¹ / ₈	3.068	2.900	2.624
4 ¹ / ₁₆	4.026	3.826	3.438
7 ¹ / ₁₆	5.761	5.761	5.189
9	7.813	7.439	6.813
11	9.750	9.314	8.500

Table E.24—Flanged Swing and Lift Check Valves (continued)

b) Regular and Full-opening Flanged Swing and Lift Check Valves, 2000 psi, 3000 psi, and 5000 psi RWP					
Nominal Size in.	L, Short Pattern Face-to-face Length			L, Long Pattern Face-to-face Length	
	2000 psi	3000 psi	5000 psi	3000 psi	5000 psi
Tolerance>	± 0.06	± 0.06	± 0.06	± 0.06	± 0.06
2 ¹ / ₁₆	11.62	14.62	14.62	—	—
2 ⁹ / ₁₆	13.12	16.62	16.62	—	—
3 ¹ / ₈	14.12	15.12	18.62	17.12	—
4 ¹ / ₁₆	17.12	18.12	21.62	20.12	—
7 ¹ / ₁₆	22.12	24.12	28.00	—	29.00
9	26.12	29.12	33.12	—	—
11	31.12	33.12	39.36	—	—

c) Regular and Full-opening Flanged Swing and Lift Check Valves, 10,000 psi, 15,000 psi, and 20,000 psi RWP			
Nominal Size in.	L, Face-to-face Length, in.		
	10,000 psi	15,000 psi	20,000 psi
Tolerance>	± 0.06	± 0.06	± 0.06
1 ¹³ / ₁₆	18.25	18.00	21.00
2 ¹ / ₁₆	20.50	19.00	23.00
2 ⁹ / ₁₆	22.25	21.00	26.50
3 ¹ / ₁₆	24.38	23.56	30.50
4 ¹ / ₁₆	26.38	29.00	—
5 ¹ / ₈	29.00	—	—
7 ¹ / ₁₆	35.00	—	—

**Table E.25—Center Spacing of Conduit Bores for Dual Parallel Bore Valves
for 2000 psi, 3000 psi, 5000 psi, and 10,000 psi**

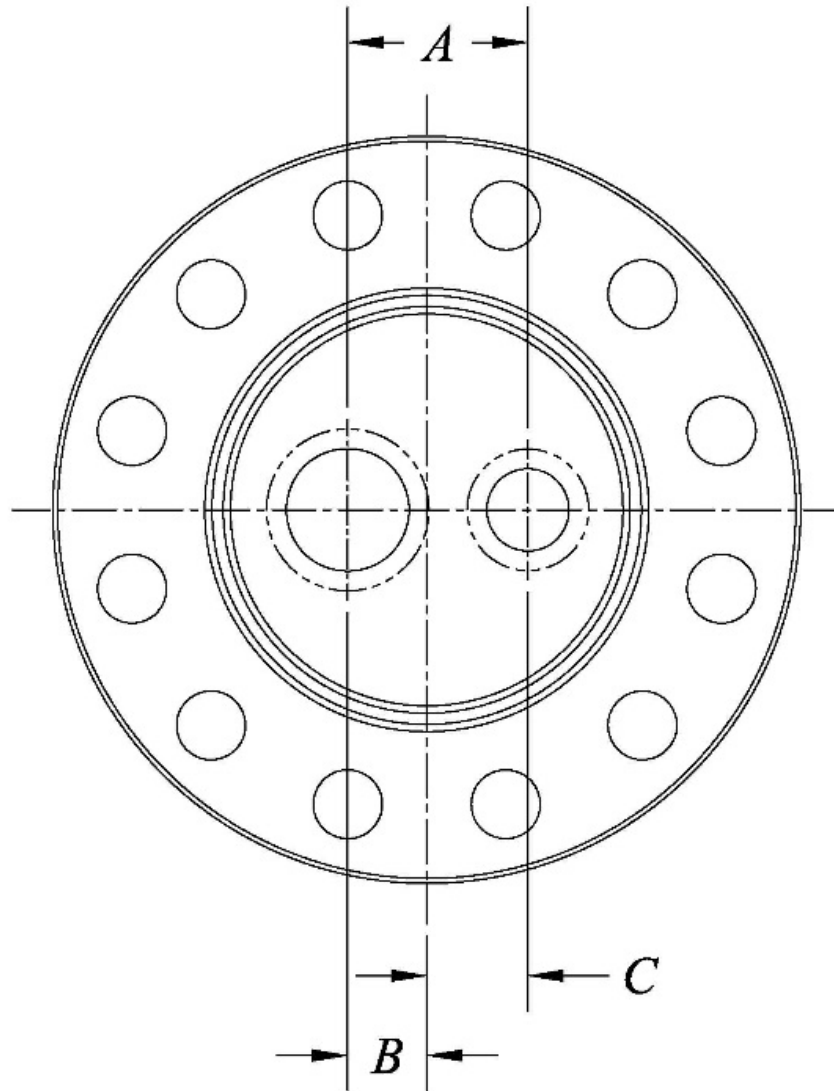

**Table E.25—Center Spacing of Conduit Bores for Dual Parallel Bore Valves
for 2000 psi, 3000 psi, 5000 psi, and 10,000 psi (continued)**

Dimensions in inches

Maximum Nominal Valve Size	Bore Center to Bore Center	Large-bore to End-connector Center	Small-bore to End-connector Center	Minimum End-connector Size	Basic Casing Size	
					OD	Lineic Mass lb/ft
2000 psi, 3000 psi, and 5000 psi						
1 ¹³ / ₁₆	2.781	1.390	1.390	7 ¹ / ₁₆	5 ¹ / ₂	17
2 ¹ / ₁₆	3.547	1.774	1.774	7 ¹ / ₁₆	7	38
2 ⁹ / ₁₆ X 2 ¹ / ₁₆	3.547	1.650	1.897	7 ¹ / ₁₆	7	29
2 ⁹ / ₁₆ X 2 ¹ / ₁₆	4.000	1.875	2.125	9	7 ⁵ / ₈	39
2 ⁹ / ₁₆	4.000	2.000	2.000	9	7 ⁵ / ₈	29.7
2 ⁹ / ₁₆	4.500	2.250	2.250	9	8 ⁵ / ₈	49
3 ¹ / ₈ X 2 ¹ / ₁₆	4.578	2.008	2.570	9	8 ⁵ / ₈	49
3 ¹ / ₈ X 2 ⁹ / ₁₆	5.047	2.524	2.524	11	9 ⁵ / ₈	53.5
3 ¹ / ₈	5.047	2.524	2.524	11	9 ⁵ / ₈	53.5
10,000 psi						
1 ¹³ / ₁₆	2.781	1.390	1.390	7 ¹ / ₁₆	5 ¹ / ₂	17
2 ¹ / ₁₆	3.547	1.774	1.774	7 ¹ / ₁₆	7	38
2 ⁹ / ₁₆ X 2 ¹ / ₁₆	3.547	1.650	1.897	7 ¹ / ₁₆	7	29
2 ⁹ / ₁₆ X 2 ¹ / ₁₆	4.000	1.875	2.125	9	7 ⁵ / ₈	39
2 ⁹ / ₁₆	4.000	2.000	2.000	9	7 ⁵ / ₈	29.7
2 ⁹ / ₁₆	4.500	2.250	2.250	9	8 ⁵ / ₈	49
3 ¹ / ₁₆	5.047	2.524	2.524	11	9 ⁵ / ₈	53.5

Table E.26—Center Spacing of Conduit Bores for Triple, Quadruple, and Quintuple Parallel Bore Valves for 2000 psi, 3000 psi, 5000 psi, and 10,000 psi

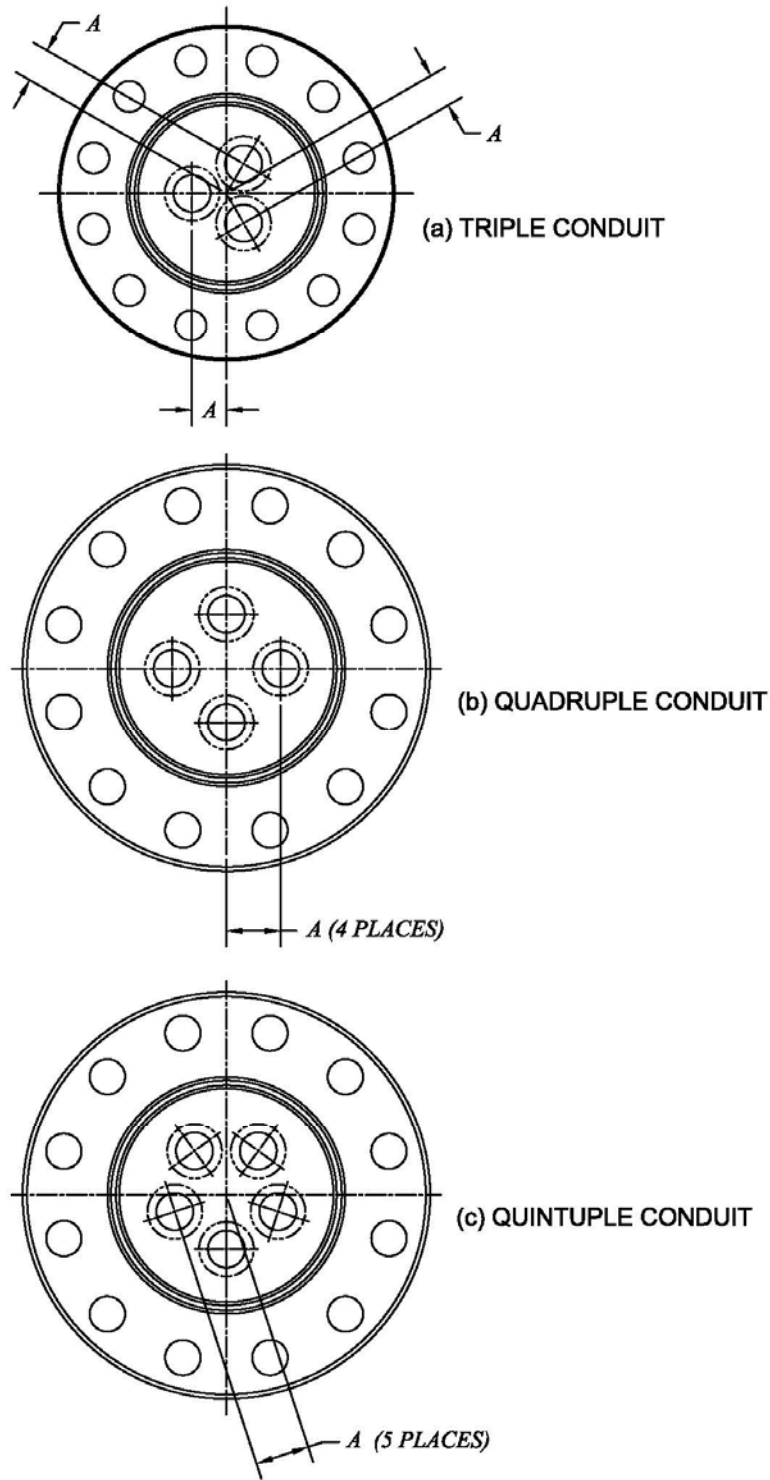

Table E.26—Center Spacing of Conduit Bores for Triple, Quadruple, and Quintuple Parallel Bore Valves for 2000 psi, 3000 psi, 5000 psi, and 10,000 psi (continued)

Dimensions in inches

Maximum Valve Size	Flange Center to Bore Center <i>A</i>	Minimum End-connector Size	Basic Casing Size	
			<i>OD</i>	Lineic Mass lb/ft
2000 psi; 3000 psi and 5000 psi RWP				
Triple-conduit Valve				
1 ¹³ / ₁₆	1.875	7 ¹ / ₁₆	6 ⁵ / ₈	24
2 ¹ / ₁₆	1.938	9	7	26
2 ¹ / ₁₆	2.125	9	7 ⁵ / ₈	39
2 ⁹ / ₁₆	2.812	11	9 ⁵ / ₈	53.5
Quadruple-conduit Valve				
1 ¹³ / ₁₆	2.875	11	8 ⁵ / ₈	36
1 ¹³ / ₁₆	3.062	11	9 ⁵ / ₈	All
2 ¹ / ₁₆	3.062	11	9 ⁵ / ₈	53.5
2 ⁹ / ₁₆	3.438	11	10 ³ / ₄	55.5
2 ⁹ / ₁₆	4.000	13 ⁵ / ₈	11 ³ / ₄	54
Quintuple-conduit Valve				
2 ¹ / ₁₆	3.062	11	9 ⁵ / ₈	53.5
10,000 psi RWP				
Triple-conduit Valve				
1 ¹³ / ₁₆	1.875	7 ¹ / ₁₆	6 ⁵ / ₈	24
2 ¹ / ₁₆	1.938	9	7	26
2 ¹ / ₁₆	2.125	9	7 ⁵ / ₈	39
2 ⁹ / ₁₆	2.812	11	9 ⁵ / ₈	53.5
Quadruple-conduit Valve				
2 ⁹ / ₁₆	3.438	11	10 ³ / ₄	55.5

Table E.27—Maximum Hanger Outside Diameter for Wellheads

Dimensions in inches

Nominal Size ^a and Minimum Through-bore of Drill-through Equipment in.	Rated Working Pressure psi	Maximum Outside Diameter of Hanger in.
7 ¹ / ₁₆	2000, 3000, and 5000	7.010
7 ¹ / ₁₆	10,000, 15,000, and 20,000	7.010
9	2000, 3000, and 5000	8.933
9	10,000 and 15,000	8.933
11	2000, 3000, and 5000	10.918
11	10,000 and 15,000	10.918
13 ⁵ / ₈	2000 and 3000	13.523
13 ⁵ / ₈	5000 and 10,000	13.523
16 ³ / ₄	2000 and 3000	16.625
16 ³ / ₄	5000 and 10,000	16.625
18 ³ / ₄	5000 and 10,000	18.625
21 ¹ / ₄	2000	21.125
20 ³ / ₄	3000	20.625
21 ¹ / ₄	5000 and 10,000	21.125

FOOTNOTE

^a Nominal size of upper end connector of wellhead body in which the hanger is used.

Table E.28—Minimum Vertical Full-opening Wellhead Body Bores and Maximum Casing Sizes

Dimensions in inches unless noted otherwise

Nominal Connector ^a		Casing Beneath Body			Minimum Vertical Full-opening Wellhead Body Bore
Nominal Size of Connector	Rated Working Pressure	Label ^b	Nominal Lineic Mass ^b	Specified Drift Diameter	
in.	psi	OD	lb/ft	in.	in.
7 ¹ / ₁₆	2000	7	17	6.413	6.45
7 ¹ / ₁₆	3000	7	20	6.331	6.36
7 ¹ / ₁₆	5000	7	23	6.241	6.28
7 ¹ / ₁₆	10,000	7	29	6.059	6.09
7 ¹ / ₁₆	15,000	7	38	5.795	5.83
7 ¹ / ₁₆	20,000	7	38	5.795	5.83
9	2000	8 ⁵ / ₈	24	7.972	8.00
9	3000	8 ⁵ / ₈	32	7.796	7.83
9	5000	8 ⁵ / ₈	36	7.700	7.73
9	10,000	8 ⁵ / ₈	40	7.600	7.62
9	15,000	8 ⁵ / ₈	49	7.386	7.41
11	2000	10 ³ / ₄	40.5	9.894	9.92
11	3000	10 ³ / ₄	40.5	9.894	9.92
11	5000	10 ³ / ₄	51.0	9.694	9.73
11	10,000	9 ⁵ / ₈	53.5	8.379	8.41
11	15,000	9 ⁵ / ₈	53.5	8.379	8.41
13 ⁵ / ₈	2000	13 ³ / ₈	54.5	12.459	12.50
13 ⁵ / ₈	3000	13 ³ / ₈	61.0	12.359	12.39
13 ⁵ / ₈	5000	13 ³ / ₈	72.0	12.191	12.22
13 ⁵ / ₈	10,000	11 ³ / ₄	60.0	10.616	10.66
16 ³ / ₄	2000	16	65	15.062	15.09
16 ³ / ₄	3000	16	84	14.822	14.86
16 ³ / ₄	5000	16	84	14.822	14.86
16 ³ / ₄	10,000	16	84	14.822	14.86
18 ³ / ₄	5000	18 ⁵ / ₈	87.5	17.567	17.59
18 ³ / ₄	10,000	18 ⁵ / ₈	87.5	17.567	17.59
20 ³ / ₄	3000	20	94	18.936	18.97
21 ¹ / ₄	2000	20	94	18.936	18.97
21 ¹ / ₄	5000	20	94	18.936	18.97
21 ¹ / ₄	10,000	20	94	18.936	18.97

FOOTNOTES

^a Upper end connectors of wellhead body.

^b Maximum size and minimum mass of casing on which bore is based.

Table E.29—Pipe Thread Counterbore and Standoff Dimensions

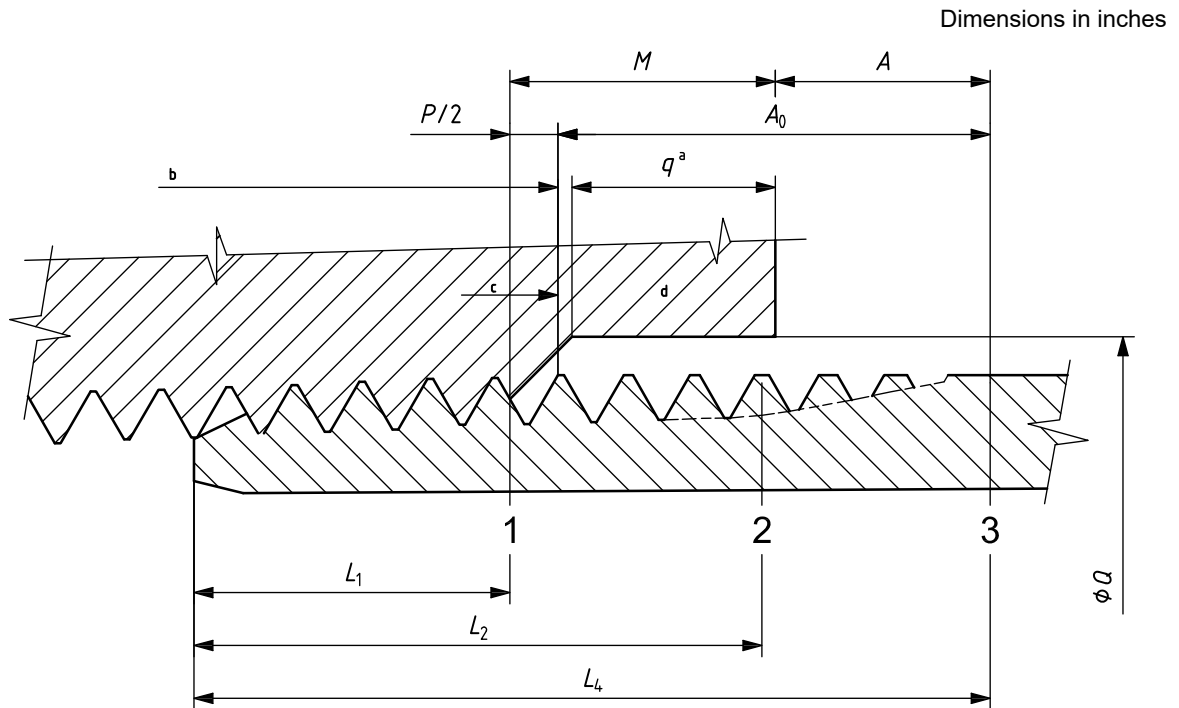
**Key**

- 1 plane of hand-tight engagement
- 2 plane of effective thread length
- 3 plane of vanish point
- a See 14.3.2.3.
- b Internal thread length.
- c Without counterbore.
- d With counterbore.

NOTE See API 5B for dimensions L_1 , L_2 , and L_4 .

Table E.29—Pipe Thread Counterbore and Standoff Dimensions (*continued*)

Dimensions in inches

Nominal Thread Size	Length: Plane of Vanish Point to Hand-tight Plane $A + M$	Hand-tight Standoff		Length: Face of Counterbore to Hand-tight Plane M	Counterbore	
		Thread without Counterbore A_0	Thread with Shallow Counterbore A		Diameter Q	Depth q
Line Pipe Threads						
1/8	0.2124	0.1939	0.0398	0.1726	0.47	0.13
1/4	0.3946	0.3668	0.2145	0.1801	0.60	0.13
3/8	0.3606	0.3328	0.1791	0.1815	0.74	0.13
1/2	0.4615	0.4258	0.1357	0.3258	0.93	0.25
3/4	0.4545	0.4188	0.1289	0.3256	1.14	0.25
1	0.5845	0.5410	0.2488	0.3357	1.41	0.25
1 1/4	0.5885	0.5450	0.2552	0.3333	1.75	0.25
1 1/2	0.6052	0.5617	0.2714	0.3338	1.99	0.25
2	0.6222	0.5787	0.2703	0.3519	2.50	0.25
2 1/2	0.8892	0.8267	0.3953	0.4939	3.00	0.38
3	0.8677	0.8052	0.3719	0.4958	3.63	0.38
3 1/2	0.8627	0.8002	0.3671	0.4956	4.13	0.38
4	0.8897	0.8272	0.3933	0.4964	4.63	0.38
5	0.9030	0.8405	0.4076	0.4954	5.69	0.38
6	0.9882	0.9257	0.4912	0.4970	6.75	0.38
8	1.0832	1.0207	0.5832	0.5000	8.75	0.38
10	1.1487	1.0862	0.6442	0.5045	10.88	0.38
12	1.1987	1.1362	0.6626	0.5361	12.94	0.38
14D	1.1217	1.0592	0.5880	0.5337	14.19	0.38
16D	1.0717	1.0092	0.5396	0.5321	16.19	0.38
18D	1.0837	1.0212	0.5512	0.5325	18.19	0.38
20D	1.1587	1.0962	0.6239	0.5348	20.19	0.38

Table E.30—Gauging of Casing and Tubing Threads

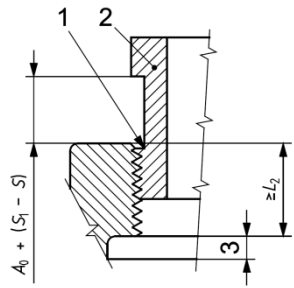

a) Internal recess without counterbore

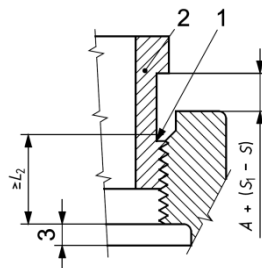

b) Internal recess with shallow counterbore

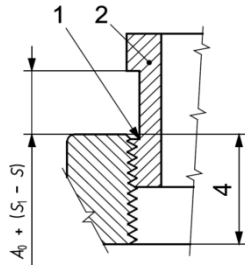

c) Thread clearance without counterbore

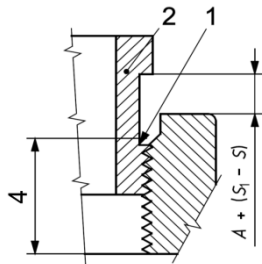

d) Thread Clearance with Shallow Counterbore

Key

- 1 gauge notch, alignment—chamfer bottom, within tolerance
- 2 working plug gauge
- 3 recess clearance
- 4 L_2 (min.) plus thread clearance

Application of Working Plug Gauge

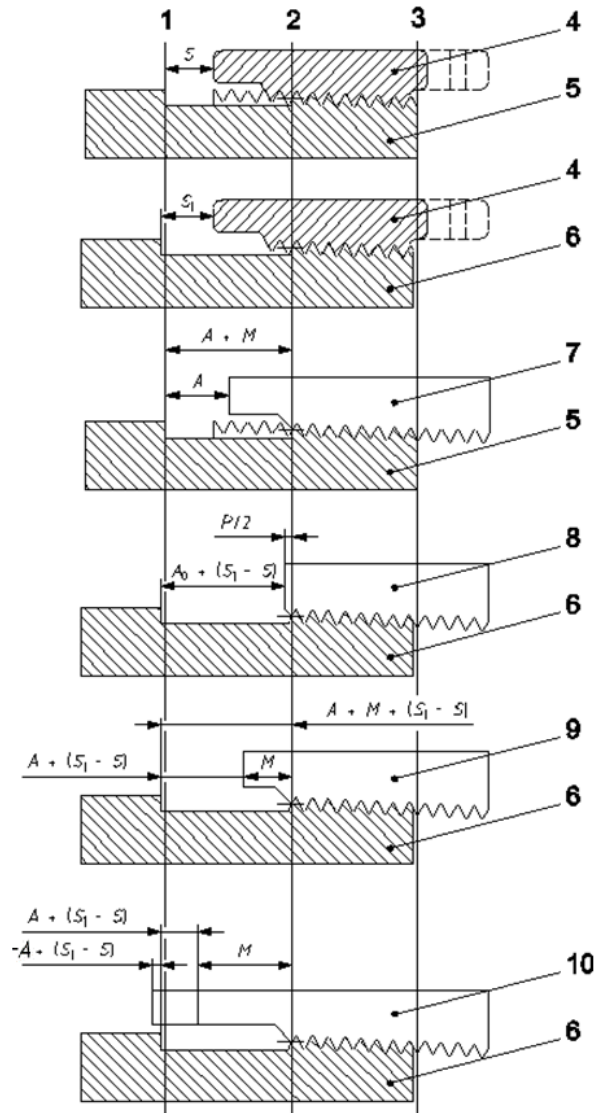

Key

- 1 plane of vanish point
- 2 plane of hand-tight engagement
- 3 plane of end of pipe
- 4 master ring gauge
- 5 master plug gauge
- 6 working plug gauge
- 7 product thread
- 8 product thread without counterbore
- 9 product thread with shallow counterbore
- 10 product thread with deep counterbore

NOTE See API 5B for dimensions of S and S_1 .

Gauging Line Pipe, Casing and Tubing Internal Threads, Hand-tight Assembly

Table E.30—Gauging of Casing and Tubing Threads (continued)

(1)	(2)	(3)	(4)	(5)	(6)	(7)
Nominal Thread Size	Length: Plane of Vanish Point to Hand-tight Plane <i>A + M</i>	Hand-tight Standoff		Length: Face of Counterbore to Hand-tight Plane <i>M</i>	Counterbore	
		Thread without Counterbore <i>A₀</i>	Thread with Shallow Counterbore <i>A</i>		Diameter <i>Q</i>	Depth <i>q</i>
Long and Short Casing Threads Dimensions in inches						
4 ¹ / ₂	1.079	1.0165	0.5907	0.4883	4.63	0.38
5	1.079	1.0165	0.5907	0.4883	5.13	0.38
5 ¹ / ₂	1.079	1.0165	0.5907	0.4883	5.63	0.38
6 ⁵ / ₈	1.079	1.0165	0.5932	0.4858	6.75	0.38
7	1.079	1.0165	0.5907	0.4883	7.13	0.38
7 ⁵ / ₈	1.146	1.0835	0.6581	0.4879	7.75	0.38
8 ⁵ / ₈	1.146	1.0835	0.6581	0.4879	8.75	0.38
9 ⁵ / ₈	1.146	1.0835	0.6581	0.4879	9.75	0.38
10 ³ / ₄ ^a	1.146	1.0835	0.6556	0.4904	10.88	0.38
11 ³ / ₄ ^a	1.146	1.0835	0.6556	0.4904	11.88	0.38
13 ³ / ₈ ^a	1.146	1.0835	0.6281	0.5179	13.56	0.38
16 ^a	1.146	1.0835	0.6256	0.5204	16.19	0.38
20 ^a	1.146	1.0835	0.6256	0.5204	20.19	0.38
Nonupset Tubing Threads Dimensions in inches						
1.050	0.646	0.5960	0.3201	0.3259	1.14	0.25
1.315	0.646	0.5960	0.3176	0.3284	1.41	0.25
1.660	0.646	0.5960	0.3201	0.3259	1.75	0.25
1.900	0.646	0.5960	0.3201	0.3259	1.99	0.25
2 ³ / ₈	0.646	0.5960	0.3026	0.3434	2.50	0.25
2 ⁷ / ₈	0.646	0.5960	0.1776	0.4684	3.00	0.38
3 ¹ / ₂	0.646	0.5960	0.1751	0.4709	3.63	0.38
4	0.784	0.7215	0.3010	0.4830	4.13	0.38
4 ¹ / ₂	0.784	0.7215	0.3010	0.4830	4.63	0.38
External Upset Tubing Threads Dimensions in inches						
1.050	0.646	0.5960	0.3176	0.3284	1.41	0.25
1.315	0.646	0.5960	0.3145	0.3315	1.57	0.25
1.660	0.646	0.5960	0.3164	0.3296	1.91	0.25
1.900	0.646	0.5960	0.3170	0.3290	2.19	0.25
2 ³ / ₈	0.784	0.7215	0.4279	0.3561	2.72	0.25
2 ⁷ / ₈	0.784	0.7215	0.3029	0.4811	3.22	0.38
3 ¹ / ₂	0.784	0.7215	0.3010	0.4830	3.88	0.38
4	0.784	0.7215	0.3010	0.4830	4.38	0.38
4 ¹ / ₂	0.784	0.7215	0.3010	0.4830	4.88	0.38
FOOTNOTE						
^a Short casing threads only (long casing threads not covered).						

Annex F (informative)

Design Validation Procedures for PR2 (PR2F Level)

F.1 Design Validation—General Requirements

F.1.1 Application

F.1.1.1 General

This annex provides design validation procedures for qualification of equipment specified by this specification, which shall be applied if specified by the manufacturer or purchaser.

NOTE 1 PR2F is to designate a product validated to PR2 level according to this annex.

The performance requirements shall apply to all products being manufactured and delivered for service (see 4.2). If this annex is applied, the design validation procedures in this annex shall be applied to designs of products, including design changes. It is intended that the validation specified in this annex shall be performed on prototypes or production models (see also 5.5).

NOTE 2 Design validation testing is not required for specified designs or features that are completely specified (dimensions and material strength) in this specification.

F.1.1.2 Alternative Procedures

NOTE Other procedures may be used, provided the test requirements of this annex are met or exceeded.

F.1.2 General

F.1.2.1 Previous Validation Conformance

NOTE Validation tests that have been completed in accordance with PR2 validation requirements of Appendix/Annex F of previous editions of API 6A during their validity are in conformance with the requirements of PR2F.

F.1.2.2 Effect of Changes in Product

F.1.2.2.1 Design Changes

A design that undergoes a substantive change shall become a new design requiring design validation. A substantive change shall be a change identified by the manufacturer that affects the performance of the product in the intended service condition.

NOTE This may include changes in fit, form, function, or material.

Fit, when defined as the geometric relationship between parts, shall include the tolerance criteria used during the design of a part and its mating parts. Fit, when defined as the state of being adjusted to or shaped for, shall include the tolerance criteria used during the design of a seal and its mating parts.

F.1.2.2.2 Metallic Materials

NOTE A change in metallic materials might not require new design validation if the suitability of the new material can be substantiated by other means.

F.1.2.2.3 Nonmetallic Seals

Substantive changes in the original, documented design configuration of nonmetallic seals resulting in a new design, shall require design validation in accordance with F.1.13.

NOTE A change in nonmetallic materials might not require new design validation if the suitability of the new material can be substantiated by other means.

F.1.3 Conformance

All products evaluated in design validation tests shall conform to the applicable design requirements of this specification. As a minimum, test articles shall be hydrostatically tested to PSL 1 prior to validation.

F.1.4 Products for Design Validation

F.1.4.1 General

Design validation, if applicable, shall be performed on prototypes or production models of equipment made in accordance with this specification to confirm that the performance requirements specified for pressure, temperature, load, mechanical cycles, and standard test fluids are met in the design of the product.

F.1.4.2 Testing Product

Design validation shall be conducted on full-size products or fixtures that represent the specified dimensions for the relevant parts of the end product being validated, unless otherwise specified in this annex.

F.1.4.3 Product Dimensions

The actual dimensions of equipment subjected to validation shall be within the allowable tolerance range for dimensions specified for normal production equipment. Worst-case conditions for dimensional tolerances should be addressed by the manufacturer, including impacts on sealing and mechanical functioning.

F.1.4.4 External Paint or Coatings

The product used in any pressure test shall be free of paint or other coatings that can impede leak detection and/or leak observation.

F.1.4.5 Maintenance Procedures

Maintenance shall be limited to the manufacturer's published maintenance procedures. Maintenance should not be performed during pressure hold periods. Maintenance procedures under this clause shall not include repairs.

NOTE Maintenance procedures may include lubrication of bearings and greasing of valves.

F.1.5 Safety

Due consideration shall be given to the safety of personnel and equipment.

F.1.6 Acceptance Criteria

F.1.6.1 Structural Integrity

The product tested shall not permanently deform to the extent that any other performance requirement cannot be met. Products that support tubulars shall be capable of supporting the rated load without collapsing the tubulars below the drift diameter.

F.1.6.2 Pressure Integrity

F.1.6.2.1 Hydrostatic Test at Ambient Temperature

The hydrostatic test at a temperature between 4 °C and 50 °C (between 40 °F and 120 °F) shall be identified as passed if no visible leakage occurs during the specified pressure hold periods of the test. The pressure change observed on the pressure-measuring device during the hold period shall be less than 5 % of the test pressure or 3.45 MPa (500 psi), whichever is less.

F.1.6.2.2 Gas Test at Ambient Temperature

The gas test at a temperature between 4 °C and 50 °C (between 40 °F and 120 °F) shall be acceptable if no sustained bubbles are observed. If leakage is observed, the rate shall be less than the rates shown in Table F.1, measured at atmospheric pressure, during specified pressure-hold periods.

Table F.1—Ambient Temperature Gas Leakage Acceptance Criteria

Equipment	Seal Type	Allowable Leakage
Valves, gate, ball, and plug	Through-bore	30 cm ³ /h/25.4 mm of nominal bore size
	Stem seal	60 cm ³ /h
	Static (bonnet seal, end connectors)	20 cm ³ /h
Valves, check	Through-bore	5 cm ³ /min/25.4 mm of nominal bore size
	Stem seal	60 cm ³ /h
	Static (bonnet seal, end connectors)	20 cm ³ /h
Chokes	Dynamic (stem seal)	60 cm ³ /h
	Static (bonnet seal, end connectors)	20 cm ³ /h
Actuators	All actuator fluid retaining seals	60 cm ³ /h
Hangers	Annular packoff or bottom casing/tubing packoff	10 cm ³ /h/25.4 mm of tubing/casing size
Tubing-head adapter, other end connectors, closures according to this specification	External closure	20 cm ³ /h

F.1.6.2.3 Minimum/Maximum Temperature Tests

The hydrostatic or gas test at high or low temperature shall be acceptable if the pressure change observed on the pressure-measuring device is less than 5 % of the test pressure or 3.45 MPa (500 psi), whichever is less.

F.1.6.3 Fluid Compatibility of Nonmetallic Seals

The acceptance criteria for the standard test fluid compatibility of nonmetallic seals shall be as specified in F.1.13.5.4.

F.1.6.4 Post-test Examination

The tested prototype shall be disassembled and inspected. All relevant items should be photographed. The examination shall include a written statement that neither the final product nor part design contains defects to the extent that any performance requirement is not met.

F.1.7 Hydrostatic Testing

F.1.7.1 Test Medium

The test medium shall be a fluid suitable for the testing temperatures. Water with or without additives, gas, hydraulic fluid, or other mixtures of fluids may be used as the test medium. The test medium shall be a fluid that remains in the liquid or gaseous state throughout the test.

F.1.7.2 Substitution of Gas

The manufacturer may substitute gas for liquid if hydrostatic testing is specified, provided the testing method and acceptance criteria for gas testing are used.

F.1.8 Gas Testing

F.1.8.1 Test Medium

NOTE Air, nitrogen, methane, or other gases or mixtures of gases may be used.

F.1.8.2 Equipment for 69.0 MPa (10,000 psi) and Above

Equipment with rated working pressures of 69.0 MPa (10,000 psi) and higher shall be gas tested.

F.1.8.3 Leak Detection

Gas testing at a temperature between 4 °C and 50 °C (between 40 °F and 120 °F) shall be conducted with a method for leak detection.

NOTE For gas testing, the product may be completely submerged in a liquid, or the product may be flooded in the seal areas being validated, such that all possible leak paths are covered. The product may be assembled with one end of a tube connected to a blind connector enclosing all possible leak paths being validated.

The other end of the tube shall be immersed in a liquid or attached to a leakage measurement device. Other methods that can detect leakage accurately are acceptable.

F.1.9 Temperature Testing

F.1.9.1 Location of Temperature Measurement

The temperature shall be measured in contact with the equipment being tested and within 13 mm ($1/2$ in.) of the through-bore, where applicable, and within 13 mm ($1/2$ in.) of the surface wetted by the retained fluid on other equipment.

NOTE As an alternative for maximum-temperature measurement, the temperature of the fluid used for heating may be employed, as long as the part is not artificially cooled.

Ambient conditions shall be at a temperature between 4 °C and 50 °C (between 40 °F and 120 °F).

F.1.9.2 Application of Heating for Maximum Temperature Testing

NOTE The heating for maximum-temperature testing may be applied internally in the through-bore or externally.

The heating shall be applied such that the entire through-bore or equivalent wetted surface is at or above the maximum temperature, or such that all fluid used for heating contained within the test articles is at or above the maximum temperature.

F.1.9.3 Application of Cooling for Minimum Temperature Testing

The cooling for minimum temperature testing shall be applied to the entire external surface of the equipment.

F.1.10 Hold Periods

F.1.10.1 Start of Hold Periods

Hold periods shall start after pressure and temperature stabilization has occurred and the equipment with a pressure-monitoring device has been isolated from the pressure source. The time specified for hold times shall be a minimum.

F.1.10.2 Pressure Stabilization

Pressure shall be considered stabilized when the rate of change is no more than 5 % of the test pressure per hour or 3.45 MPa (500 psi), whichever is less. Pressure shall remain within 5 % of the test pressure or within 3.45 MPa (500 psi), whichever is less, during the hold period.

F.1.10.3 Temperature Stabilization

Temperature shall be considered stabilized when the rate of change is less than 0.5 °C/min (1 °F/min). The temperature shall remain at or beyond the extreme during the hold period but should not go beyond the upper and lower temperatures by more than 11 °C (20 °F).

F.1.11 Pressure and Temperature Cycles

F.1.11.1 Pressure/Temperature Cycles

Pressure/temperature cycles shall be performed as specified in F.1.11.3, unless otherwise specified in F.2 for the specific product being tested.

F.1.11.2 Test Pressure and Temperature

The test pressure and temperature extremes shall be as specified in 4.3.

F.1.11.3 Test Procedure

Pressure shall be monitored and controlled during temperature change. The following procedure shall be followed.

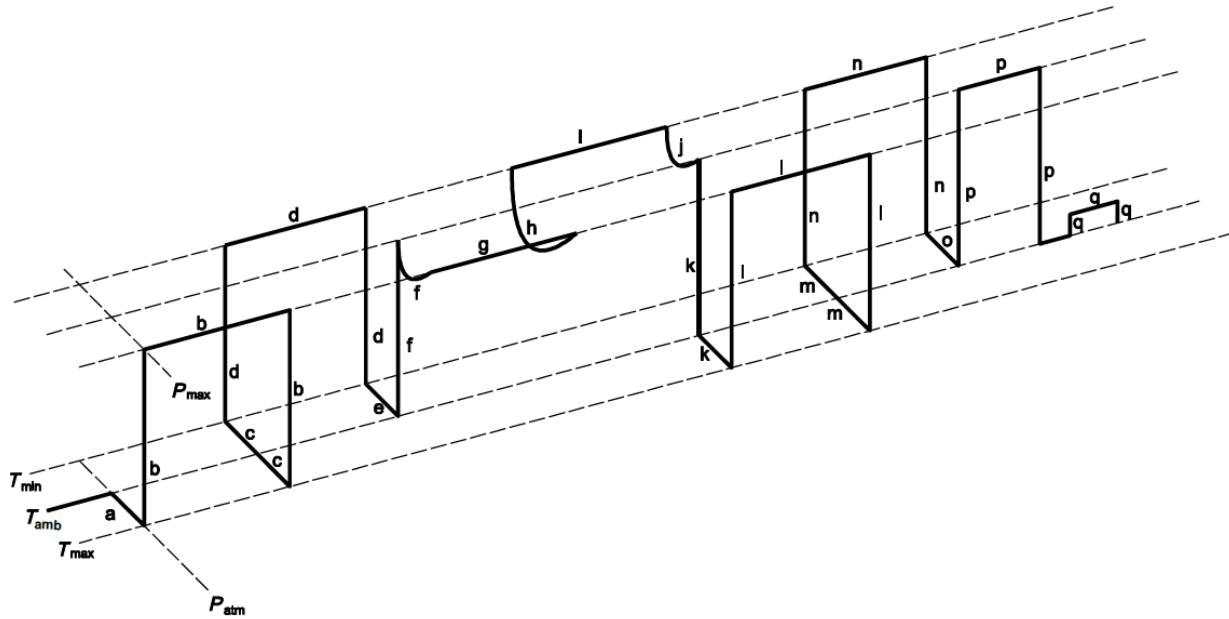

Figure F.1—Test Procedure

NOTE Letters correspond to the steps in the following list. There are three thermal cycles identified in the procedure of F.1.11.3: 1st thermal cycle is steps a) through e); 2nd thermal cycle is steps f) through j); and 3rd thermal cycle is steps k) through o).

- a) Start at a temperature between 4 °C and 50 °C (between 40 °F and 120 °F) with atmospheric pressure and raise temperature to the maximum.
- b) Apply the test pressure, hold for a minimum period of 1 h, and then release the pressure.
- c) Lower temperature to the minimum.
- d) Apply the test pressure, hold for a minimum period of 1 h, and then release the pressure.
- e) Raise the temperature to a temperature between 4 °C and 50 °C (between 40 °F and 120 °F).
- f) Apply the test pressure at a temperature between 4 °C and 50 °C (between 40 °F and 120 °F) and maintain at 50 % to 100 % of test pressure while raising temperature to the maximum.
- g) Hold for a minimum period of 1 h at test pressure.
- h) Reduce the temperature to the minimum while maintaining 50 % to 100 % of test pressure.
- i) Hold for a minimum period of 1 h at test pressure.
- j) Raise the temperature to a temperature between 4 °C and 50 °C (between 40 °F and 120 °F) while maintaining 50 % to 100 % of test pressure.
- k) Release the pressure, then raise the temperature to the maximum.
- l) Apply the test pressure, hold for a minimum period of 1 h, and then release the pressure.
- m) Reduce the temperature to the minimum.
- n) Apply the test pressure, hold for a minimum period of 1 h, and then release the pressure.
- o) Raise the temperature to a temperature between 4 °C and 50 °C (between 40 °F and 120 °F).
- p) Apply the test pressure, hold for a minimum period of 1 h, and then release the pressure.
- q) Apply 5 % to 10 % of the test pressure, hold for a minimum period of 1 h, and then release the pressure.

F.1.12 Load and Mechanical Cycles

Load testing and mechanical cycles shall be performed as specified in F.2 for the specific product being tested.

F.1.13 Testing of Nonmetallic Seals

F.1.13.1 Nonmetallic Seals

Nonmetallic seals that are exposed to retained fluids shall undergo the design validation procedure described in F.1.13.

F.1.13.2 Intent of Procedure

The intent of this procedure is to validate the performance of the seal for the standard test fluid rating as specified in F.1.13.4, not the performance of products containing the seal. The full-size seals shall be tested as specified in F.1 or F.2 to determine temperature and pressure performances.

F.1.13.3 Temperature of Record

The temperature of record shall be the stabilized temperature measured in contact with the fixture as specified in F.1.9.

F.1.13.4 Test Medium

The test medium shall be the standard test fluid specified in Table F.2 for the material's class rating.

F.1.13.5 Thermochemical Performance of Seal Materials

F.1.13.5.1 General

The fluid compatibility of the seal materials for the intended service shall be validated by a test demonstrating the response of the seal material to exposure to the standard test fluid, at or above the maximum rated temperature of the seal.

F.1.13.5.2 Immersion Testing

F.1.13.5.2.1 General

A sample immersion test, comparing physical and mechanical properties prior to and after exposure to the standard test fluids, temperature, and pressure as stated below, shall be performed. This test shall be in addition to the full-scale pressure and temperature testing of F.1 or F.2, as specified.

F.1.13.5.2.2 Test Fluid

The standard test fluids for the material classes are listed in Table F.2. The nonmetallic material being evaluated shall be totally immersed in the hydrocarbon liquid. A hydrocarbon liquid quantity equal to 60 % of the test vessel volume shall be charged in the test vessel. Water equal to 5 % of the test vessel volume shall also be charged in the test vessel. The hydrocarbon liquid shall be overpressurized with the appropriate gas or gas mixture for the standard test fluid.

Table F.2—Standard Test Fluids for Nonmetallic Seals

Material Class	Hydrocarbon Liquid Phase ^a	Gas Phase
AA/BB	b	5 % vol. fraction CO ₂ /95 % vol. fraction CH ₄
CC	b	80 % vol. fraction CO ₂ /20 % vol. fraction CH ₄
DD/EE	b	10 % vol. fraction H ₂ S/5 % vol. fraction CO ₂ /85 % vol. fraction CH ₄
FF/HH	b	10 % vol. fraction H ₂ S/80 % vol. fraction CO ₂ /10 % vol. fraction CH ₄
FOOTNOTES		
^a Water shall be added to the liquid phase.		
^b Hydrocarbon liquid phase selected at the manufacturer's discretion may include, but is not limited to, jet fuel, diesel, kerosene, etc.		

F.1.13.5.2.3 Temperature

The test temperature shall be either the maximum specified temperature rating for the temperature class being tested or the maximum temperature at the seal location (see F.1.9) for the equipment at the maximum test temperature class of the test product, as established by product testing and/or design analysis.

During the exposure period, the rate of temperature change shall be less than 0.5 °C (1 °F) per minute and shall not exceed the extreme by more than 11 °C (20 °F).

F.1.13.5.2.4 Pressure

The test pressure, after heating to the test temperature, shall be maintained at 6.9 MPa ± 0.7 MPa (1000 psi ± 100 psi), with adjustments made as necessary.

F.1.13.5.2.5 Exposure Period

The test exposure period shall be a minimum of 160 h (see F.1.10).

F.1.13.5.3 Fixture Testing**F.1.13.5.3.1 General**

NOTE Alternatively, the standard test fluid tests may be run at or above the maximum rated temperature and pressure with a reduced or full-size seal in fixtures or products that represent the nominal specified clearances and extrusion gaps specified on the manufactured part.

F.1.13.5.3.2 Exposure Test Conditions

The following shall apply.

- a) Test fluid: The standard test fluids for the material classes are listed in Table F.2. The fixture shall be positioned so the seal is partially exposed to both the liquid and gas phases. A hydrocarbon liquid quantity equal to 60 % of the test fixture volume shall be charged in the test fixture. Water equal to 5 % of the test fixture volume shall also be charged in the test fixture. The hydrocarbon liquid shall be overpressurized with the appropriate gas or gas mixture for the material class being tested.
- b) Temperature: The test temperature shall be either the maximum specified temperature rating for the temperature class being tested (see F.1.9) or the maximum temperature at the seal location for the equipment at the maximum test temperature class of the test product, as established by product testing and/or design analysis.

The temperature shall remain at or beyond the extreme during the exposure period, but shall not exceed the extreme by more than 11 °C (20 °F) with a rate of change less than 0.5 °C (1 °F) per minute.

- c) Pressure: The test pressure, after heating to the test temperature, shall be the rated working pressure of the seal.
- d) Time period: The test exposure period shall be a minimum of 160 h.

F.1.13.5.3.3 Exposure Test Requirements

The following shall apply.

- a) High-temperature pressure test: After the completion of a minimum of 160 h of exposure, monitor for leakage for a minimum of 1 h.
- b) Room-temperature pressure test: At the completion of the high-temperature pressure test, cool the test fixture and release the pressure. At a temperature of 25 ± 5 °C (75 ± 10 °F) and no pressure in the test fixture, pressurize the test fixture using air, nitrogen, methane, or other gases or mixture of gases to the rated working pressure of the seal. Hold for a minimum of 1 h (see F.1.10). At the end of the hold period, reduce the pressure to zero.
- c) Low-temperature pressure test: Lower the temperature of the test fixture to the minimum specified temperature rating for the temperature class being tested (see F.1.9). Pressurize the test fixture using air, nitrogen, methane, or other gases or mixture of gases to the rated working pressure of the seal. Hold for a minimum of 1 h (see F.1.10). At the end of the hold period, reduce the pressure to zero and let the test fixture temperature return to a temperature between 4 °C and 50 °C (between 40 °F and 120 °F).

F.1.13.5.4 Acceptance Criteria—Thermochemical Performance

F.1.13.5.4.1 Acceptance Criteria

The acceptance criteria for the standard test fluid compatibility of nonmetallic seals exposed to sample immersion testing of F.1.13.5.2 shall be documented. The acceptance criteria for the nonmetallic seals exposed to the fixture testing of F.1.13.5.3 shall be as follows.

F.1.13.5.4.2 160-hour Exposure Period

The pressure change recorded on the pressure-measuring device during the exposure period shall be less than 5 % of the test pressure or 3.45 MPa (500 psi), whichever is less.

F.1.13.5.4.3 High-temperature Pressure Test

The pressure change recorded on a pressure-measuring device during the high-temperature hold period shall be less than 5 % of the test pressure or 3.45 MPa (500 psi), whichever is less. Fluid displacement for fixture leak detector (bubble-type indicator) shall be less than 100 cm³. Sustained leakage of bubbles shall not exceed 20 cm³/h.

F.1.13.5.4.4 Room-temperature Pressure Test

The pressure change recorded on the pressure-measuring device during the hold period shall be less than 5 % of the test pressure or 3.45 MPa (500 psi), whichever is less. Fluid displacement for fixture leak detector (bubble-type indicator) shall be less than 20 cm³. Sustained leakage of bubbles shall not exceed 20 cm³/h.

F.1.13.5.4.5 Low-temperature Pressure Test

The pressure change recorded on the pressure-measuring device during the hold period shall be less than 5 % of the test pressure or 3.45 MPa (500 psi), whichever is less. Fluid displacement for fixture leak detector (bubble type indicator) shall be less than 20 cm³. Sustained leakage of bubbles shall not exceed 20 cm³/h.

F.1.13.5.4.6 Alternative Testing Acceptance

A material that passes the immersion testing of F.1.13.5.2 shall be acceptable without running the fixture testing of F.1.13.5.3.

A material that passes the fixture testing of F.1.13.5.3 shall be acceptable even if it fails the immersion testing of F.1.13.5.2.

A material that fails the fixture testing of F.1.13.5.3 shall not be acceptable.

F.1.14 Scaling

F.1.14.1 Scaling

NOTE Scaling may be used to validate the members of a product family in accordance with the requirements and limitations described in F.1.14.

F.1.14.2 Product Family

A product family shall meet the following design requirements.

- a) Configuration: The design principles of physical configuration and functional operation are the same.
- b) Design stress levels: The design stress levels in relation to material mechanical properties are based on the same criteria.

F.1.14.3 Limitations of Scaling

F.1.14.3.1 Design Validation by Pressure Rating

NOTE The test product may be used to validate products of the same family having equal or lower-pressure ratings.

F.1.14.3.2 Design Validation by Size

F.1.14.3.2.1 General

Testing of one size of a product family shall validate products one nominal size larger and one nominal size smaller than the tested size.

NOTE Testing of two sizes also validates all nominal sizes between the two sizes tested.

F.1.14.3.2.2 Determination of Choke Nominal Size

The choke nominal size shall be defined as the size of the maximum orifice that can be used in that choke (orifice sizes smaller than the nominal size do not require testing). Choke nominal sizes are in 25 mm (1 in.) increments.

F.1.14.3.2.3 Determination of Valve Nominal Size

The valve nominal size shall be defined as the nominal size of the end connectors, as defined in F.1.14.3.2.6.

NOTE For valves of the same product family (as defined in F.1.14.2), where entries in Table F.3 group two sizes together, such as "1¹³/₁₆ in. or 2¹/₁₆ in.," the size groupings may be considered as one size for scaling purposes.

F.1.14.3.2.4 Determination of Other End-connector Nominal Sizes

The nominal sizes of OECs shall be defined as the nominal size of the end connector, as defined in F.1.14.3.2.6 1).

F.1.14.3.2.5 Determination of Hanger and Packoff Nominal Sizes

The nominal size of hangers and packoffs that are sized by pipe ODs and wellhead IDs shall be defined by either the wellhead connector or the pipe. The manufacturer shall choose whether the size is determined by the connector or the pipe. The manufacturer shall be consistent in the practice of choosing sizes.

F.1.14.3.2.6 Nominal Sizes

The following shall apply.

- 1) Nominal connector sizes shall be as given in Table F.3.

Table F.3—Nominal End Connector Sizes

Inches
1 ¹³ / ₁₆ or 2 ¹ / ₁₆
2 ⁹ / ₁₆
3 ¹ / ₁₆ or 3 ¹ / ₈
4 ¹ / ₁₆ or 4 ¹ / ₈
5 ¹ / ₈
7 ¹ / ₁₆
9
11
13 ⁵ / ₈
16 ³ / ₄
18 ³ / ₄
20 ³ / ₄ or 21 ¹ / ₄
26 ³ / ₄
30

- 2) Nominal pipe sizes shall be as given in Table F.4.

Table F.4—Nominal Pipe Sizes

Inches
2 ¹ / ₁₆
2 ³ / ₈
2 ⁷ / ₈
3 ¹ / ₂
4
4 ¹ / ₂
5
5 ¹ / ₂
6 ⁵ / ₈
7
7 ⁵ / ₈
8 ⁵ / ₈
9 ⁵ / ₈
10 ³ / ₄
11 ³ / ₄
13 ³ / ₈
16
18 ⁵ / ₈
20

F.1.14.3.2.7 Determination of Actuator Nominal Size

Sizes shall be determined by the manufacturer.

F.1.14.3.3 Design Validation by Temperature Rating

The temperature range validated by the test product shall validate all temperature classes that fall entirely within that range.

F.1.14.3.4 Design Validation by Standard Test Fluid Rating for Nonmetallic Seals

The standard test fluid rating validated by the test product shall validate all products of the same product family and material properties as the test product (see Table F.5).

Table F.5—Scaling for Nonmetallic Seals

Material of Products Tested	Classes of Products Validated
AA/BB	AA, BB
CC	AA, BB, CC
DD/EE	AA, BB, DD, EE
FF/HH	AA through HH

F.1.14.3.5 Design Validation by PSL

Validation of equipment shall be independent of the PSL of the production equipment.

F.1.15 Documentation**F.1.15.1 Design Validation Files**

The manufacturer shall maintain a file on each design validation.

F.1.15.2 Contents of Validation Files

Validation files shall contain or reference the following information, if applicable:

- a) test number and revision level, or test procedure;
- b) complete identification of the product being tested, including identification of product family, if applicable;
- c) date of test completion;
- d) test results and post-test examination conclusions (see F.1.6.4);
- e) maintenance performed on tested equipment.

NOTE This may include a record that identifies the test phase in which the maintenance was performed.

EXAMPLE Examples include quantity/type of lubricant, plastic packing, applied maintenance torque, lubrication of fittings, or pressure boundary penetrations.

- f) model numbers and other pertinent identifying data on all other sizes, rated working pressures, temperature ranges, and standard test fluid ratings of products of the same product family that are qualified by the validation of this particular product;
- g) class of seal designs (static, dynamic);
- h) all detailed dimensional drawings and material specifications applicable to the tested product, including seals and nonextrusion devices;
- i) sketch of test fixture, product and seal or sample; temperature and pressure measurement locations should be shown;
- j) actual sealing-surface dimensions;
- k) all test data specified in this annex, including actual test conditions (pressure, temperature, etc.) and observed leakages or other acceptance parameters;
- l) identification of testing media used;
- m) test equipment identification and calibration status;
- n) certification of manufacturer report, including the supplier of test seals, molding dates, compound identifications, and batch numbers for nonmetallic materials;
- o) certificate of conformance that the tested equipment is in accordance with the design requirements of this specification.

F.1.16 Test Equipment Calibration Requirements

F.1.16.1 General

NOTE The calibration requirements for equipment necessary to conduct the design validation tests described in this annex are described in F.1.16.

Test equipment for pressure-measuring, load-measuring, temperature-measuring, torque-measuring, elastomer physical and mechanical-property-measurement, and any other equipment used to measure, or record test conditions and results shall be calibrated.

Except for specific requirements in F.1.16.2, the manufacturer's instructions shall provide all the requirements for the identification, control, calibration, adjustment, intervals between calibrations and accuracy of all the testing equipment to which this specification is applicable.

F.1.16.2 Measuring and Testing Equipment

Equipment for measuring dimensions shall be controlled and calibrated by the methods specified in this specification to maintain the accuracy required by the manufacturer's specification. Equipment for measuring dimensions for which this specification is not applicable shall be controlled and calibrated by the manufacturer's written specifications to maintain the accuracies required by this annex. Test pressure-measuring devices shall conform to the requirements of 10.2.

F.1.16.3 Status

When used for validation, equipment shall be calibrated in accordance with the requirements of the manufacturer and this specification.

F.2 Product-specific Design Validation

F.2.1 General

F.2.1.1 Design Validation

NOTE Procedures that are specific and unique to the product being tested are contained in F.2.

The procedures shall be in addition to the procedures of F.1, unless otherwise specified in Annex F.

F.2.1.2 Acceptance Criteria

Unless noted otherwise, acceptance criteria for specific steps in F.2 shall be in accordance with F.1.

F.2.1.3 Re-energization

Any seal requiring re-energization during the test, except as specified in the product operating procedures, shall be retested.

F.2.1.4 Actuated Valves, Chokes, or Other Actuated Products

Valves, chokes, or other products designed for actuators shall have the same design validation as the manually actuated products.

Design validation of a manual valve or choke shall validate an actuated valve or choke and design validation of actuated valve or choke shall validate a manual valve or choke, provided that the basic design is the same, and functional differences between manual and actuated designs are subjected to appropriate validation through fixture testing or product testing. These functional differences shall include, but not be limited to, the following:

- stem-seal design;
- stem size;
- stem movement (linear vs. rotary);
- bonnet design;
- relative speed of operation (hydraulic vs. pneumatic).

The manufacturer shall have documentation and/or validation to support the application of the actuated valve, choke, or other product to the type of actuator, hydraulic or pneumatic.

F.2.1.5 Bottom Casing Packoff

NOTE Bottom casing packoffs are considered part of the hanger but may be tested separately.

F.2.2 Design Validation for PR2F Valves

F.2.2.1 General

NOTE See Table F.6 for a summary of design validation requirements for valves.

Table F.6—Summary of Design Validation Requirements for Valves

Performance Requirement	PR2F
Open/close cycling dynamic pressure test at a temperature between 4 °C and 50 °C (between 40 °F and 120 °F)	160 cycles as specified in F.2.2
Low-pressure seat test at a temperature between 4 °C and 50 °C (between 40 °F and 120 °F)	1 h hold period at 5 % to 10 % of rated working pressure as specified in F.2.2
Open/close cycling dynamic pressure gas test at maximum and minimum temperatures	20 cycles at each extreme as specified in F.2.2
Low-pressure seat test at maximum and minimum temperatures	1 h hold period at 5 % to 10 % of rated working pressure as specified in F.2.2
Operating force or torque	As specified in F.2.2
Pressure/temperature cycling	As specified in F.1.11
Testing of nonmetallic seals	As specified in F.1.13

Acceptance criteria, unless noted otherwise for specific steps in F.2.2, shall be in accordance with F.1.

F.2.2.2 Design Validation Procedure

F.2.2.2.1 Force or Torque Measurement

F.2.2.2.1.1 General

The break-away and running torques or forces shall be measured.

NOTE 1 This is not applicable to check valves.

NOTE 2 The torque or forces may be determined by direct or indirect measurements (i.e. pressure applied to an area).

F.2.2.2.1.2 Procedure

The procedure shall be determined and documented by the manufacturer.

F.2.2.2.1.3 Acceptance Criteria

The operating forces or torques shall be within the manufacturer's specifications.

F.2.2.2.2 Dynamic Test at Ambient Temperature

F.2.2.2.2.1 Procedure for Gate, Ball, and Plug Valves

Gate, ball, and plug valves shall be tested as follows.

- a) Fill the downstream end of the valve with the test medium at 1 % or less of test pressure.
- b) Apply pressure equal to the rated working pressure against the upstream side of the gate, ball, or plug. All subsequent seat tests shall be in the same direction.
- c) Open the valve fully, starting against the full differential pressure. Pressure shall be maintained at a minimum of 50 % of the initial test pressure after the initial partial opening. The opening stroke may be interrupted to adjust the pressure within the above limits.
- d) Close the valve fully while pressure is maintained within the limits of the preceding step.

- e) Bleed the downstream pressure to 1 % or less of test pressure after the valve is fully closed.
- f) Repeat the above steps until a minimum of 160 open-and-close cycles have been carried out.

F.2.2.2.2 Procedure for Check Valves

Check valves shall be tested as follows.

- a) Apply pressure equal to the rated working pressure to the downstream side of the valve, while the upstream side is vented to atmosphere.
- b) Relieve the pressure to 1 % or less of test pressure and unseat the valve.

Repeat F.2.2.2.2 a) and F.2.2.2.2 b) until a minimum of 160 pressure cycles have been carried out.

F.2.2.2.3 Dynamic Test at Maximum Rated Temperature

This test shall be performed at maximum rated temperature in accordance with F.2.2.2.2, except that the minimum number of open-and-close cycles shall be 20 and the test medium shall be gas.

F.2.2.2.4 Gas Body Test at Maximum Rated Temperature

This test shall be performed at maximum rated temperature as follows.

- a) Gate, ball, and plug valves shall be in the partially open position during testing. Test check valves from the upstream side.
- b) Test pressure shall be the rated working pressure.
- c) The hold period shall be as specified in F.1.11.3 b), but do not release the pressure at the end of the hold period.

F.2.2.2.5 Gas Seat Test at Maximum Rated Temperature

At the end of the hold period of F.2.2.2.4, the valve shall be closed. The rated working pressure shall be maintained on the upstream side of the gate, ball, or plug and release it on the downstream side. Check valves shall be tested from the downstream side. There shall be one hold period of not less than 1 h duration; then release the pressure.

F.2.2.2.6 Low-pressure Seat Test at Maximum Rated Temperature

The valves shall be subjected to a differential pressure of no less than 5 % and no more than 10 % of the rated working pressure. The pressure shall be applied on the upstream side of the gate, ball, or plug and released on the downstream side for one hold period of a minimum of 1 h. For check valves, the low-pressure seat test pressure shall be applied on the downstream end of the valve with the opposite end vented to the atmosphere.

F.2.2.2.7 Dynamic Test at Minimum Rated Temperature

A dynamic test at minimum rated temperature shall be performed as specified in F.2.2.2.2, except that the minimum number of open-and-close cycles shall be 20, and the test medium shall be gas.

F.2.2.2.8 Gas Body at Minimum Rated Temperature

This test shall be performed in accordance with F.2.2.2.4, except at minimum rated temperature.

F.2.2.2.9 Gas Seat Test at Minimum Rated Temperature

This test shall be performed in accordance with F.2.2.2.5, except at minimum rated temperature.

F.2.2.2.10 Low-pressure Seat Test at Minimum Rated Temperature

This test shall be performed in accordance with F.2.2.2.6, except at minimum rated temperature.

F.2.2.2.11 Body Pressure-temperature Cycles

Steps F.1.11.3 e) through F.1.11.3 o) shall be performed with gate, ball, and plug valves partially open.

F.2.2.2.12 Body Pressure Holding Test at Ambient Temperature

Step F.1.11.3 p) shall be performed with gate, ball, and plug valves partially open, but do not release the pressure.

F.2.2.2.13 Gas Seat Test at Ambient Temperature

The valve shall be closed. The rated working pressure shall be maintained on the upstream side of the gate, ball, or plug and released on the downstream side. Check valves shall be tested from the downstream side. There shall be one pressure-holding period of not less than 15 min duration; then release the pressure.

F.2.2.2.14 Body Low-pressure Holding Test at Ambient Temperature

Step F.1.11.3 q) shall be performed on gate, ball, and plug valves with the valve partially open.

F.2.2.2.15 Low-pressure Seat Test at Ambient Temperature

Valves shall be subjected to a differential pressure of no less than 5 % and no more than 10 % of the rated working pressure. One hold period of a minimum of 1 h duration shall be applied (in each direction, for bidirectional valves). For check valves, the low-pressure seat test pressure shall be applied on the downstream end of the valve, with the opposite end vented to atmosphere.

F.2.2.2.16 Final Force or Torque Measurement

This test shall be performed in accordance with F.2.2.2.1.

F.2.3 Design Validation for PR2F Actuators**F.2.3.1 General**

NOTE See Table F.7 for a summary of design validation requirements for actuators.

Actuators, including electric actuators, shall be subjected to a functional test to demonstrate proper assembly and operation. Test medium for pneumatic actuators shall be a gas. Test medium for hydraulic actuators shall be a suitable hydraulic fluid. The actuator shall be tested either on a valve/choke or on a fixture that simulates the opening/closing dynamic force profile of a valve/choke. A fixture test of a valve operator shall include the reduction in resisting force and resulting motion of the stem that occur when the valve is opened against differential pressure. If the bonnet assembly is part of the actuator, a validation of the stem seal and bonnet design shall be performed to validate these design elements to the requirements for valves.

Table F.7—Summary of Design Validation Requirements for Actuators

Performance Requirement	PR2F
Operating force or torque measurement	As specified in F.2.2.2.1
Actuator seal test at a temperature between 4 °C and 50 °C (between 40 °F and 120 °F)	3 cycles as specified in F.2.3.2.1
Dynamic open/close pressure cycling at a temperature between 4 °C and 50 °C (between 40 °F and 120 °F)	160 cycles as specified in F.2.3.2.2
Dynamic open/close cycling test at maximum temperature	20 cycles as specified in F.2.3.2.3
Dynamic open/close cycling at minimum temperature	20 cycles as specified in F.2.3.2.4
Pressure/temperature cycles	As specified in F.2.3.2.5

F.2.3.2 Testing**F.2.3.2.1 Actuator Seal Test at Ambient Temperature**

Actuator seals shall be pressure-tested in two steps by applying a pressure of 20 % and of 100 % of the rated working pressure to the actuator. The minimum hold period for each test pressure shall be 10 min at 20 % pressure and 5 min at 100 % pressure for pneumatic actuators and 3 min at each test pressure for hydraulic actuators. This actuator seal test shall be repeated a minimum of three times.

F.2.3.2.2 Dynamic Open/Close Cycling Test at Ambient Temperature

The actuator shall be tested for proper operation by cycling the actuator an equivalent of 160 open-close valve cycles. The acceptance criteria shall be within the manufacturer's specifications. The pressure applied shall be equal to the rated working pressure of the actuator. Test power supplied to electric actuators shall be in accordance with the electrical design requirements.

F.2.3.2.3 Dynamic Open/Close Cycling Test at Maximum Rated Actuator Temperature

The actuator shall be tested for proper operation by cycling the actuator an equivalent of 20 open-close valve cycles at the maximum rated temperature of the actuator. The acceptance criteria shall be within the manufacturer's specifications. The pressure applied shall be equal to the rated working pressure of the actuator. Test power supplied to electric actuators shall be in accordance with the electrical design requirements.

F.2.3.2.4 Dynamic Open/Close Cycling Test at Minimum Rated Actuator Temperature

The actuator shall be tested for proper operation by cycling the actuator an equivalent of 20 open-close valve cycles, at minimum rated temperature of the actuator. The acceptance criteria shall be within the manufacturer's specifications. The pressure applied shall be equal to the rated working pressure of the actuator. Test power supplied to electric actuators shall be in accordance with the electrical design requirements.

F.2.3.2.5 Pressure/Temperature Cycles

The pressure/temperature cycles shall be steps F.1.11.3 e) through F.1.11.3 q).

F.2.4 Design Validation for PR2F Chokes**F.2.4.1 General**

NOTE 1 Design validation of an adjustable choke also validates a positive choke which has the same body design and seat seal design. For testing of a positive choke, the dynamic test cycles (F.2.4.4, F.2.4.5, and F.2.4.7) are not required.

NOTE 2 See Table F.8 for a summary of design validation requirements for chokes.

Table F.8—Summary of Design Validation Requirements for Chokes

Performance Requirement	PR2F
Operating force or torque measurement	As specified in F.2.4.2
Body static pressure test	Not applicable
Seat-to-body seal test at a temperature between 4 °C and 50 °C (between 40 °F and 120 °F)	As specified in F.2.4.3
Dynamic open/close cycling pressure test at a temperature between 4 °C and 50 °C (between 40 °F and 120 °F) ^a	160 cycles as specified in F.2.4.4
Dynamic open/close cycling pressure test at maximum temperature ^a	20 cycles as specified in F.2.4.5
Gas body test at maximum rated temperature	As specified in F.2.4.6
Dynamic open/close cycling pressure test at minimum temperature ^a	20 cycles as specified in F.2.4.7
Gas body at minimum rated temperature	As specified in F.2.4.8
Body pressure/temperature cycling	As specified in F.2.4.9
Body pressure-holding test at a temperature between 4 °C and 50 °C (between 40 °F and 120 °F)	As specified in F.2.4.10
Body low-pressure holding test	As specified in F.2.4.11
Second seat-to-body at a temperature between 4 °C and 50 °C (between 40 °F and 120 °F)	As specified in F.2.4.12
Testing of nonmetallic seals	As specified in F.1.13
FOOTNOTE	
^a Does not apply to a positive choke.	

F.2.4.2 Force or Torque Measurement

F.2.4.2.1 General

The break-away and running torques or forces shall be measured.

NOTE The forces may be determined by direct or indirect measurements (i.e. pressure applied to an area).

F.2.4.2.2 Procedure

The procedure shall be determined and documented by the manufacturer.

F.2.4.2.3 Acceptance Criteria

The operating forces or torque shall be within the manufacturer's specifications.

F.2.4.3 Hydrostatic Seat-to-body Seal Test

The hydrostatic seat-to-body seal test shall be performed at a temperature between 4 °C and 50 °C (between 40 °F and 120 °F) by applying rated working pressure and holding for a minimum of 1 h to confirm the integrity of the seat-to-body seal.

NOTE 1 A blind seat may be used for this test at the manufacturer's option.

NOTE 2 For an adjustable choke, a separate test or fixture test may be performed to confirm the integrity of the seat-to-body seal, in accordance with F.2.4.3, F.2.4.9, F.2.4.10, and F.2.4.11. In this case, F.2.4.12 may be omitted.

F.2.4.4 Dynamic Open/Close Cycling Pressure Test at Ambient Temperature

The rated working pressure shall be applied, and the stem cycled at rated working pressure a minimum 160 times open-close-open. The mating parts shall be free of all lubrication not specified in the manufacturer's part or assembly specifications or maintenance procedures. The acceptance criteria shall be within the manufacturer's written specifications. Adjust the internal pressure to compensate for expansion and contraction of the test fluid chamber.

F.2.4.5 Dynamic Open/Close Cycling Pressure Test at Maximum Rated Temperature

A dynamic cycling test shall be performed at the maximum rated temperature by repeating F.2.4.4, except as follows.

- The temperature shall be equal to the maximum temperature.
- The test medium shall be gas.
- Cycle the stem 20 times open to close and back to open.

F.2.4.6 Gas Body at Maximum Rated Temperature

A gas body test shall be performed at maximum rated temperature as follows.

- The choke shall be in the partially open position during testing.
- Test pressure shall be the rated working pressure.
- One hold period of a minimum of 1 h duration shall be applied.

F.2.4.7 Dynamic Test at Minimum Rated Temperature

A dynamic test shall be performed at the minimum rated temperature by repeating F.2.4.5, except at the minimum rated temperature.

F.2.4.8 Gas Body at Minimum Rated Temperature

A gas body test shall be performed at the minimum rated temperature as follows.

- The choke shall be in the partially open position during testing.
- Test pressure shall be the rated working pressure.
- One hold period of a minimum of 1 h duration shall be applied.

F.2.4.9 Body Pressure/Temperature Cycles

Steps F.1.11.3 e) through F.1.11.3 o) shall be performed with the seat open.

F.2.4.10 Body Pressure Holding Test at Ambient Temperature

Step F.1.11.3 p) shall be performed with the seat open, but do not release the pressure.

F.2.4.11 Body Low-pressure Holding Test at Ambient Temperature

Step F.1.11.3 q) shall be performed with the seat open.

F.2.4.12 Second Seat-to-body Seal Test at Ambient Temperature

A second hydrostatic seat-to-body seal test shall be performed by applying rated working pressure at a temperature between 4 °C and 50 °C (between 40 °F and 120 °F) and holding for a minimum of 1 h to confirm the integrity of the seat-to-body seal after pressure/temperature cycle testing.

NOTE A blind seat may be used for this test at the manufacturer's option.

F.2.5 Design Validation for PR2F Casing-head Housings, Casing-head Spools, Tubing-head Spools, Crossover Connectors, and Adapter and Spacer Spools

F.2.5.1 General

NOTE See Table F.9 for a summary of design validation requirements for casing-head housings, casing-head spools, tubing-head spools, crossover connectors, and adapter and spacer spools.

F.2.5.2 Deformation

NOTE The deformation of casing-head housings, casing-head spools, and tubing-head spools due to hanger loading is outside the scope of this annex.

Products shall be capable of sustaining rated loads without deformation to the extent that other required performance characteristics cannot be met.

Table F.9—Summary of Design Validation Requirements for Casing-head Housings, Casing-head Spools, Tubing-head Spools, Crossover Connectors, and Adapter and Spacer Spools

Performance Requirement	PR2F
Pressure	As specified in F.2.5.4
Thermal cycles	Objective evidence
Penetrations	As specified in F.2.15
Fluid compatibility	Objective evidence

F.2.5.3 Penetrations

NOTE 1 Penetrations for lock screws, hanger pins, and retainer screws are not addressed in performance testing of these members but are addressed in F.2.15.

NOTE 2 Fittings and pressure boundary penetrations are addressed in F.2.20.

F.2.5.4 Testing

Design validation shall be achieved through production hydrostatic pressure testing as required for the PSL to which the equipment is manufactured (see 10.4.7).

F.2.6 Design Validation for PR2F Group 1 Slip-type Hangers

F.2.6.1 General

Load cycling capacity testing shall consist of three hold periods at maximum rated load capacity, and two hold periods at the minimum rated load capacity, with 5 min minimum for each hold period, as shown in Figure F.2.

NOTE The pressure/temperature cycles of F.1.11 are not required.

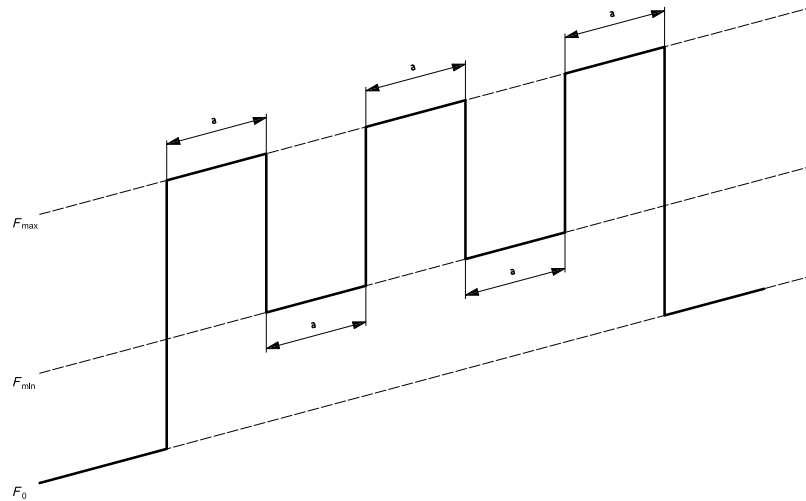

FOOTNOTE

^a Five minutes.

Figure F.2—Load Cycle Testing for Hangers

F.2.6.2 Load Cycling

The load cycle test in accordance with Figure F.2 shall be performed.

F.2.7 Design Validation for PR2F Group 2 Slip-type Hangers

F.2.7.1 General

NOTE See Table F.10 for a summary of design validation requirements for group 2 slip-type hangers.

Table F.10—Summary of Design Validation Requirements for Group 2 Slip-type Hangers

Performance Requirement	PR2F
Load cycling	As specified in F.2.6
Pressure seal(s)	As specified in F.1.11
Fluid compatibility	As specified in F.1.13

F.2.7.2 Pressure/Temperature Testing with Load

Cycle testing shall be performed in accordance with F.1.11 from either direction A or direction B (see Figure F.3). If the manufacturer’s pressure rating at the maximum rated load is not equal to the rated working pressure, the test shall be repeated using the rated working pressure of the hanger with the manufacturer’s rated hanging load at that pressure.

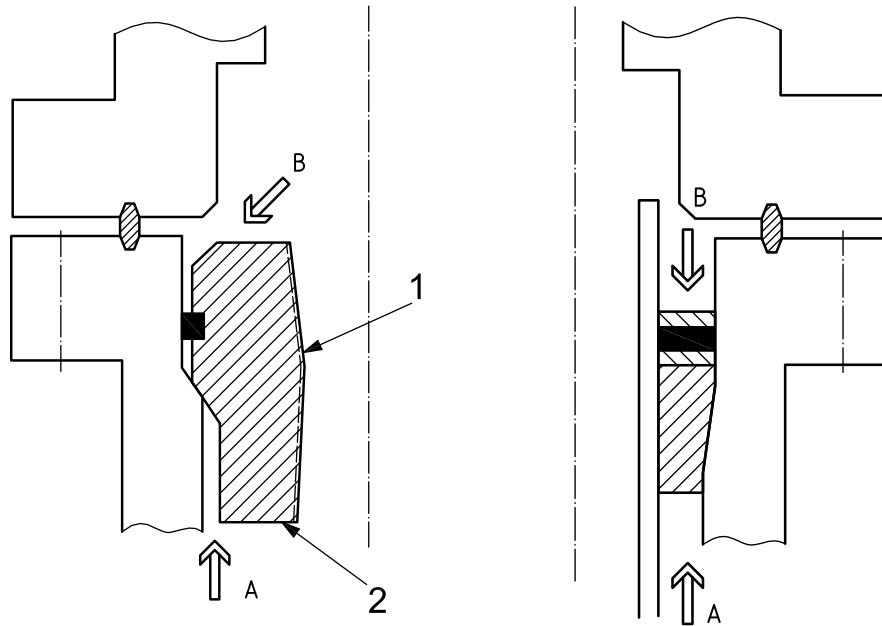
**Key**

1 well bore pressure area

2 annular pressure area

A, B Directions of pressure application (see text).

Figure F.3—Group 2 and Group 3 Hangers**F.2.8 Design Validation for PR2F Group 3 Slip-type Hangers**

NOTE See Table F.11 for a summary of design validation requirements for group 3 slip-type hangers.

Table F.11—Summary of Design Validation Requirements for Group 3 Slip-type Hangers

Performance Requirement	PR2F
Load cycling	As specified in F.2.6
Pressure from above seal(s)	As specified in F.1.11 and F.2.8
Thermal cycle	As specified in F.1.11 and F.2.8
Fluid compatibility	As specified in F.1.13
Pressure from below seal(s)	As specified in F.1.11 and F.2.8

Validation testing shall be the same as for PR2F group 2 slip-type hangers, with the addition of a separate test in the same manner but with external pressure across the annular packoff in the other direction, as identified in Figure F.3. The bottom casing packoff shall be tested from above in the same manner. The ring joint pressure area shall be hydrostatically tested, as identified in Figure F.4, at the rated working pressure at a temperature between 4 °C and 50 °C (between 40 °F and 120 °F), one time for a 5 min minimum hold period.

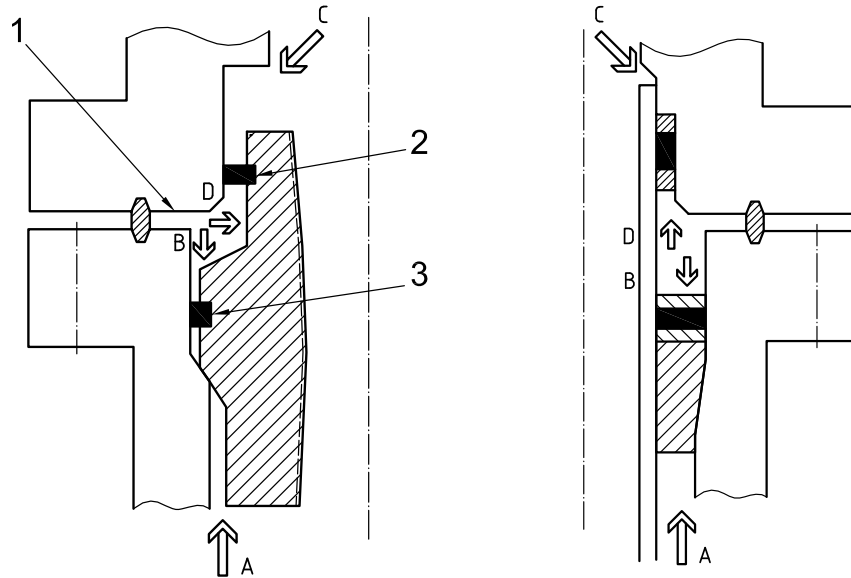

Key

- 1 ring-gasket pressure area
- 2 bottom casing packoff
- 3 annular seal

A, B, C, D Directions of pressure application (see text).

Figure F.4—Group 3 Hangers with Crossover Seal

If the manufacturer’s pressure rating from below is different from the pressure rating from above, a test at the appropriate pressure for each direction shall be performed.

NOTE The bottom casing packoff may be cycle-tested separately, as shown in Figure F.6, or concurrently with the packoff, as shown in Figure F.7 or Figure F.8.

F.2.9 Design Validation for PR2F Group 4 Slip Hangers

NOTE See Table F.12 for a summary of design validation requirements for group 4 slip-type hangers.

Table F.12—Summary of Design Validation Requirements for Group 4 Slip-type Hangers

Performance Requirement	PR2F
Load cycling	As specified in F.2.6
Pressure from above seal(s)	As specified in F.1.11
Thermal cycle	As specified in F.1.11
Fluid compatibility	As specified in F.1.13
Pressure from below seal(s)	As specified in F.1.11
Retention feature test by annular pressure	As specified in F.1.11 with the hanger held in place by a retention feature with minimum rated tubular load and maximum annular pressure from below only

Validation testing shall be the same as PR2F group 3 hangers, with an additional test of the retention feature in accordance with Table F.12.

F.2.10 Design Validation for PR2F Group 1 Mandrel-type Hangers

F.2.10.1 General

NOTE See Table F.13 for a summary of design validation requirements for group 1 mandrel-type hangers.

Table F.13—Summary of Design Validation Requirements for Group 1 Mandrel-type Hangers

Performance Requirement	PR2F
Load cycling	As specified in F.2.10
Internal pressure test	As specified in F.2.10

F.2.10.2 Internal Pressure Test

One internal pressure test shall be performed at a temperature between 4 °C and 50 °C (between 40 °F and 120 °F) with a hold period of 15 min at rated working pressure.

If the product does not meet the thread manufacturer's dimensional and material strength requirements, then the threaded connector shall be tested.

NOTE The test may be performed in a fixture separate from the hanger.

F.2.10.3 Load Cycling

The hanger shall be load-tested per F.2.6. Load testing of the end connectors shall not be required.

F.2.11 Design Validation for PR2F Group 2 Mandrel-type Hangers

F.2.11.1 General

NOTE See Table F.14 for a summary of design validation requirements for group 2 mandrel-type hangers.

Table F.14—Summary of Design Validation Requirements for Group 2 Mandrel-type Hangers

Performance Requirement	PR2F
Load cycling	As specified in F.2.11
Pressure seal(s)	As specified in F.1.11
Thermal cycling seal(s)	As specified in F.1.11
Fluid compatibility	As specified in F.1.13
Internal pressure test	As specified in F.2.11

F.2.11.2 Load Cycling

The load cycle test shall be performed as specified in F.2.6.

F.2.11.3 Internal Pressure Test

The hangers shall be internally pressure-tested as specified for PR2F group 1 mandrel hangers (see F.2.10.2).

F.2.12 Design Validation for PR2F Group 3 Mandrel-type Hangers

F.2.12.1 General

NOTE See Table F.15 for a summary of design validation requirements for group 3 mandrel-type hangers.

Table F.15—Summary of Design Validation Requirements for Group 3 Mandrel-type Hangers

Performance Requirement	PR2F
Load cycling	As specified in F.2.12
Internal pressure tests	As specified in F.2.12
Thermal cycling seal(s)	As specified in F.1.11 and F.2.12
Fluid compatibility	As specified in F.1.13
Pressure from below seal(s)	As specified in F.1.11 and F.2.12
Pressure from above seal(s)	As specified in F.1.11 and F.2.12

F.2.12.2 Downhole Control Line

If downhole control-line or electric-cable preparations are included, they shall hold the rated working pressure and be subjected to the same testing requirements as the hanger.

F.2.12.3 Pressure Cycle

Validation testing shall be the same as for PR2F group 2 mandrel-type hangers, with the addition of a separate test in the same manner, but with external pressure from the opposite side of the annular seal, as identified in Figure F.3.

NOTE 1 For extended-neck hangers, see Figure F.4.

The bottom casing packoff shall be tested in the same manner from the top and the bottom. The ring-gasket pressure area shall be hydrostatically tested for extended-neck hangers at the rated working pressure at a temperature between 4 °C and 50 °C (between 40 °F and 120 °F), one time for a 5 min minimum hold period.

NOTE 2 Figures F.5, F.6, F.7, and F.8 show schematic representations of the pressure and temperature cycle test requirements.

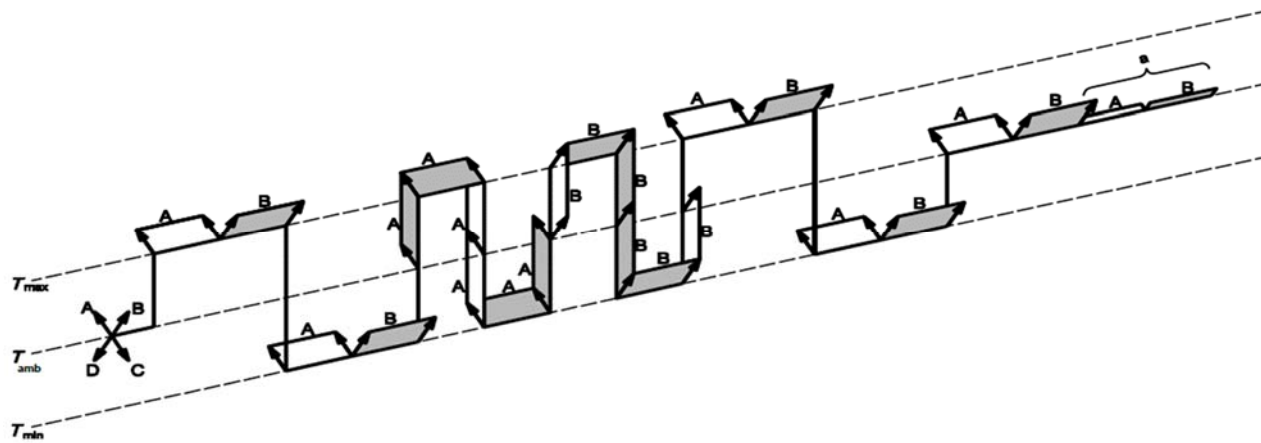

FOOTNOTES

^a 5 % to 10 %.

NOTE Pressure directions A and B are shown in Figures F.3 and F.4.

Figure F.5—Pressure/Temperature Cycles for Group 3 Slip and Mandrel-type Hangers without Bottom Casing Packoff

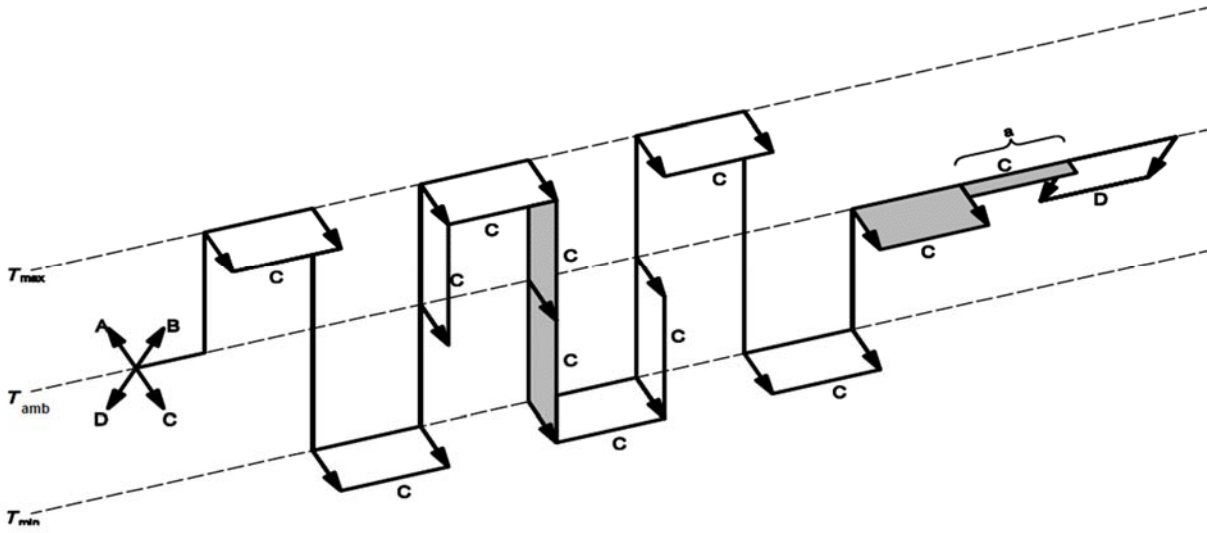

FOOTNOTES

^a 5 % to 10 %.

NOTE Pressure directions C and D are shown in Figure F.4.

Figure F.6—Pressure/Temperature Cycles for Group 3 Slip and Mandrel-type Hangers with Bottom Casing Packoff Tested Separately

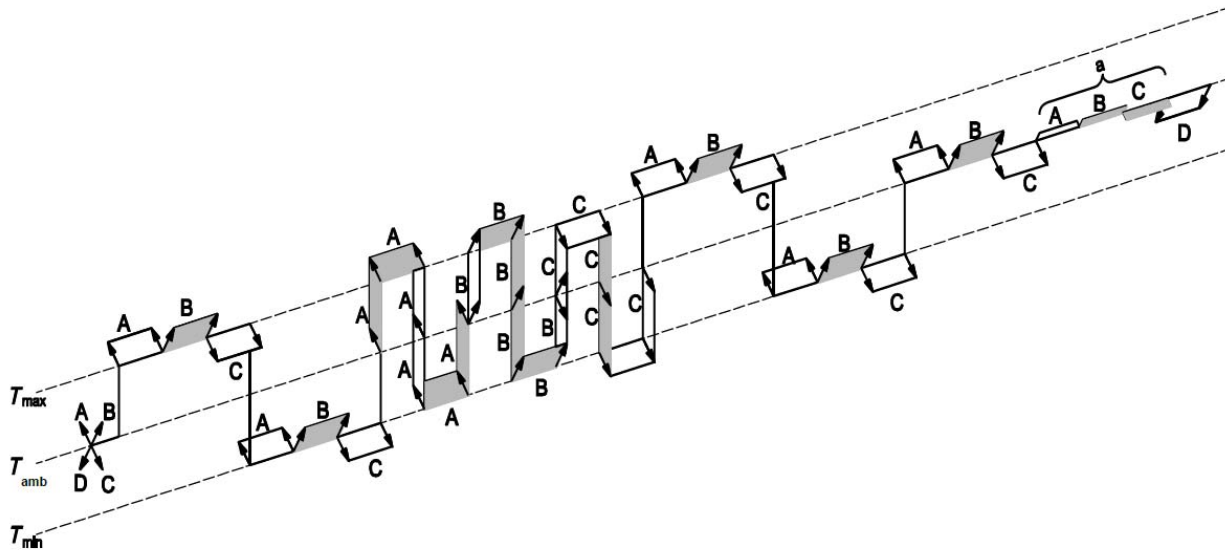

FOOTNOTES

^a 5 % to 10 %.

NOTE Pressure directions A, B, C, and D are shown in Figure F.4.

Figure F.7—Pressure/Temperature Cycles for Group 3 Slip and Mandrel-type Hangers with Bottom Casing Packoff Tested Concurrently

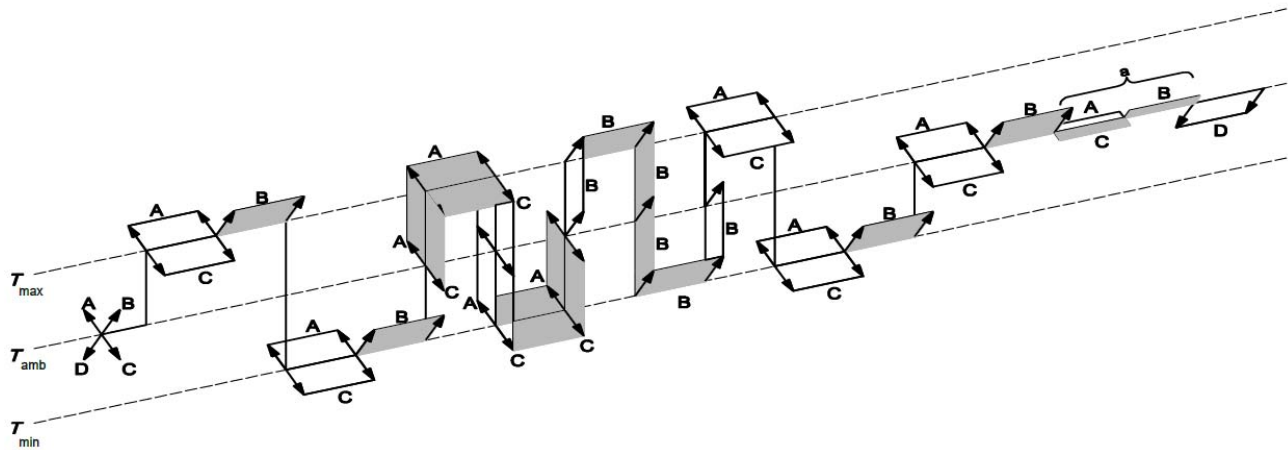

FOOTNOTES

^a 5 % to 10 %.

NOTE Pressure directions A, B, C, and D are shown in Figure F.4, with A and C tested together.

Figure F.8—Pressure/Temperature Cycles for Group 3 Slip and Mandrel-type Hangers with Bottom Casing Packoff Tested Concurrently

F.2.12.4 Internal Pressure Test

Hangers shall be internally pressure-tested as specified for PR2F group 1 mandrel-type hangers in F.2.10.2.

F.2.12.5 Load Cycling

The load cycle test shall be performed as specified in F.2.6.

F.2.13 Design Validation for PR2F Group 4 Mandrel Hangers

F.2.13.1 General

NOTE See Table F.16 for a summary of design validation requirements for group 4 mandrel hangers.

Table F.16—Summary of Design Validation Requirements for Group 4 Mandrel-type Hangers

Performance Requirement	PR2F
Load cycling	As specified in F.2.6
Internal pressure test	As specified in F.2.13
Thermal cycling seal(s)	As specified in F.1.11 and F.2.13
Fluid compatibility	As specified in F.1.13
Pressure from below seal(s)	As specified in F.1.11 and F.2.13
Pressure from above seal(s)	As specified in F.1.11 and F.2.13
Retention feature test by annular pressure	As specified in F.1.11 and F.2.13 with the hanger held in place by a retention feature with minimum rated tubular load and maximum annular pressure from below only

F.2.13.2 Pressure/Temperature Cycling

Validation testing shall be the same as for PR2F group 3 hangers. Three pressure/temperature cycles shall be performed as specified in F.1.11 while the hanger is held in place by the retention feature.

F.2.13.3 Internal Pressure Test

Hangers shall be internally pressure-tested as specified for PR2F group 1 mandrel hangers in F.2.10.2.

F.2.14 Design Validation for PR2F Group 5 Mandrel-type Hangers

F.2.14.1 General

NOTE See Table F.17 for a summary of design validation requirements for group 5 mandrel-type hangers.

Table F.17—Summary of Design Validation Requirements for Group 5 Mandrel-type Hangers

Performance Requirement	PR2F
Load cycling	As specified in F.2.6
Internal pressure test	As specified in F.2.14
Thermal cycling	As specified in F.1.11 and F.2.14
Fluid compatibility	As specified in F.1.13
Pressure from below seal(s)	As specified in F.1.11 and F.2.14
Pressure from above annular seal(s)	As specified in F.1.11 and F.2.14
Retention feature test by full blind pressure	As specified in F.1.11 and F.2.14 with the hanger held in place by a retention feature with minimum rated tubular load and maximum full blind pressure from below only
Back-pressure valve preparation test	As specified in F.2.14

F.2.14.2 Pressure/Temperature Cycling

Validation testing shall be the same as for PR2F group 4 hangers, except for the test hanger retention feature with a full blind annular seal load as specified in F.1.11 with pressure from below. The back-pressure valve preparation shall be independently pressure-tested at a temperature between 4 °C and 50 °C (between 40 °F and 120 °F) to rated working pressure of the hanger, cycled from atmospheric to rated working pressure three times with 5 min minimum hold periods with the pressure applied against the lower end of the back-pressure valve preparation.

F.2.14.3 Internal Pressure Test

Hangers shall be internally pressure-tested as specified for PR2F group 1 mandrel-type hangers in F.2.10.2.

F.2.15 Design Validation for Packing Mechanisms for PR2F Lock Screws, Alignment Pins, and Retainer Screws

NOTE See Table F.18 for a summary of design validation requirements for packing mechanisms for lock screws, alignment pins, and retainer screws.

Table F.18—Summary of Design Validation Requirements for Packing Mechanisms for Lock Screws, Alignment Pins, and Retainer Screws

Performance Requirement	PR2F
Pressure and thermal cycling	As specified in F.1.11
Operating force or torque	Shall withstand manufacturer's rated force or torque as specified in F.2.15

A simulated maximum load shall be applied at the manufacturer's recommended torque and then the pressure/temperature cycle test of F.1.11 shall be performed.

F.2.16 Design Validation for PR2F Group 1 Tubing-head Adapters

Design validation shall be achieved through production hydrostatic pressure testing as required for the PSL to which the equipment is manufactured (see 11.2).

F.2.17 Design Validation for PR2F Group 2 Tubing-head Adapters

F.2.17.1 General

NOTE See Table F.19 for a summary of design validation requirements for group 2 tubing-head adapters.

Table F.19—Summary of Design Validation Requirements for Group 2 Tubing-head Adapters

Performance Requirement	PR2F
Load cycling	As specified in F.2.17
Internal pressure test	As specified in F.2.17
Thermal cycling	Objective evidence
Fluid compatibility	Objective evidence

F.2.17.2 Load Cycling

The load cycle test shall be performed as specified in F.2.11.

F.2.17.3 Internal Pressure Test

The internal pressure test of the tubing-head adapter shall be performed, including the end connectors, as specified in F.2.16.

One internal pressure test shall be performed at a temperature between 4 °C and 50 °C (between 40 °F and 120 °F) with a hold period of 15 min at rated working pressure.

If the product does not meet the thread manufacturer's dimensional and material strength requirements, then the threaded connector shall be tested.

NOTE The test may be performed in a fixture separate from the hanger.

F.2.18 Design Validation for PR2F Other End Connectors

F.2.18.1 General

NOTE See Table F.20 for a summary of design validation requirements for OECs.

Table F.20—Summary of Design Validation Requirements for Other End Connectors

Performance Requirement	PR2F
Pressure and thermal cycles	As specified in F.1.11
Bending moments	Subject connector to manufacturer's rated load that produces the highest stress case for one cycle
Make-and-break	Subject connector to manufacturer's rated make-and-break cycles (if applicable)
Fluid compatibility	As specified in F.1.13

F.2.18.2 PR2F Validation Test

The entire connector shall be tested as specified in F.1.11.

F.2.18.3 Make-and-break Cycles

The connector shall be subjected to the manufacturer's rated make-and-break cycles independent of the test in F.2.18.2. The working pressure shall be applied to the connector for a 5 min hold period after each make-up of the connector.

F.2.18.4 Bending Moments

The connector shall be subjected to the manufacturer's rated load case for one cycle to the highest stress case determined for the connector, independent of the tests in F.2.18.2 and F.2.18.3.

F.2.19 Design Validation for Ring Gaskets, Bolting, and Other Specified Products

NOTE Validation testing is not required for specified flanged or studed end and outlet connectors, threaded end and outlet connectors, closure bolting, ring joint gaskets, bullplugs, tees and crosses, test and gauge connector ports, and other specified products that are completely specified (dimensions and materials) by this specification.

F.2.20 Qualification for Fittings and Pressure Boundary Penetrations**F.2.20.1 General**

Fittings and pressure boundary penetrations shall be validated either separately or installed on the equipment.

Fittings and pressure boundary penetrations shall be free of all lubrication, unless specified in the manufacturer's specifications or maintenance procedures.

If validation of the fittings is performed independently from the equipment, the test pressure shall be, at a minimum, the rated working pressure of the fitting. If validation of the fitting is performed installed on equipment, the test pressure shall be, at a minimum, the rated working pressure of the equipment.

F.2.20.2 Test Procedure

This test shall be performed with the secondary sealing device removed or compromised if allowed by the design. An additional step shall be completed to validate the sealing capability of the secondary device. If there is more than one sealing device in series, they shall be qualified separately.

Test the complete assembly as follows.

- a) Apply test pressure to the fitting.

- b) Bleed pressure. If the fitting function requires bleeding or equalizing pressure, bleed pressure to zero by unseating the fitting.
- c) Reseat the primary sealing device, if applicable.
- d) Apply test pressure, hold for a period of 15 min, then release the pressure.
- e) Test the complete assembly in accordance with F.1.11.
- f) Apply test pressure to the fitting.
- g) Bleed pressure. If the fitting function requires bleeding or equalizing pressure, bleed pressure to zero by unseating the fitting.
- h) Reseat the primary sealing device, if applicable.
- i) Apply test pressure, hold for a period of 15 min, then release the pressure.

If a secondary barrier is included in the design, defeat the primary sealing device, replace the secondary sealing device to the fitting and repeat steps a) through i) for the secondary sealing device.

Annex G (informative)

Design and Rating of Equipment for Use at Elevated Temperatures

G.1 General

In accordance with 4.3.2, the design of equipment for temperatures above 121 °C (250 °F) shall include the effects of temperature on material strength.

NOTE 1 This annex provides two methods that may be used for the design and rating of equipment for use at elevated temperatures. The first is to de-rate the working pressure of the equipment at the elevated temperature to a pressure less than the room-temperature full-rated working pressure of the equipment. The second is to design the equipment for full-rated working pressure at the elevated temperature.

NOTE 2 Data on the performance of flanged end connectors, as specified in this specification, at elevated temperatures are available in API 6AF1.

Caution—Annex G is not intended as a material selection guide for high-temperature use. Some alloys are embrittled after repeated or prolonged exposure to elevated temperatures. Care should be used in selection of alloys for these ratings. If plated or coated materials are used at temperatures greater than 180 °C (350 °F), the cracking potential can be increased.

G.2 Elevated Temperature Ratings

NOTE The temperature ratings given in Table G.1 may be used for equipment for service temperatures in excess of those covered by Section 4.

Table G.1—Temperature Ratings

Classification	Temperature Range	
	°C	°F
X	-18 to 180	0 to 350
Y	-18 to 345	0 to 650

G.3 Pressure-temperature De-rating

NOTE 1 The rated working pressure of equipment may be de-rated for temperature ratings X and Y.

De-rated equipment shall be marked in accordance with G.4.

NOTE 2 The de-rated temperatures and pressures of Table G.2 may be used for equipment with 6B flanges. Alternative de-rated pressures may be used for OECs, or for flanges specified in this specification based on the data of API 6AF1.

Table G.2—Optional Pressure-temperature Ratings for 6B Flanges

Pressure Rating for Classes K to U MPa (psi)	De-rated Pressure	
	Class X, MPa (psi)	Class Y, MPa (psi)
13.8 (2000)	13.1 (1905)	9.9 (1430)
20.7 (3000)	19.7 (2860)	14.8 (2145)
34.5 (5000)	32.8 (4765)	24.7 (3575)

FOOTNOTE
See Table G.1 for temperature ratings.

G.4 Marking of De-rated Equipment

In addition to the marking requirements of Section 12, equipment supplied for temperature ratings above 250° F (121° C) that is de-rated shall have the de-rated working pressure for the applicable maximum temperature marked on the equipment.

G.5 Design of Equipment for Use at Elevated Temperature

G.5.1 General

It has been demonstrated that some flanges specified in this specification are capable of being used at full working pressure at elevated temperatures. In addition, some OECs are capable of being used at full-rated working pressure at elevated temperature. One purpose of this annex is to provide rules for the design of equipment for operation at full-rated working pressure at elevated temperature.

A second purpose of this annex is to provide rules for the design of de-rated equipment for use at elevated temperatures.

G.5.2 Procedure

G.5.2.1 General

De-rated equipment may be designed in accordance with the rules of API 6X, extended to include high-temperature cases as follows.

There is no change to the rules of design for hydrostatic test conditions, since shell testing is carried out at a temperature between 4 °C and 50 °C (between 40 °F and 120 °F).

For the operating conditions that include rated working pressure and loading at rated temperature, an S_m value may be used equal to two-thirds of a de-rated material yield strength, S_e , at rated temperature. De-rated yield strength may be determined by one of the methods given in G.5.2.2 or G.5.2.3.

Elevated-temperature tensile strength shall be determined in the same manner as the elevated-temperature yield strength.

G.5.2.2 Testing at Elevated Temperature

G.5.2.2.1 QTC Testing

S_e at temperature shall be the minimum measured yield strength of the material tested at the rated temperature of the equipment. The room-temperature mechanical properties of the material shall equal or exceed the minimum requirements for the strength class of Table 8. The elevated-temperature tensile test(s) shall be performed on specimens removed from the required location within the same QTC used for room-temperature tensile testing. At least one elevated-temperature tensile test shall be performed at the rated temperature of the equipment, using the methods of ASTM E21 or equivalent methods.

If the elevated-temperature yield strength, E_{ty} , meets or exceeds the minimum specified room-temperature yield strength, S_{my} , of Table 8, then S_{my} may be used as S_e for the design. If the E_{ty} is less than the S_{my} , then a value no greater than E_{ty} shall be used as S_e for the design.

If the elevated-temperature test fails to meet the above requirements on the first attempt, two additional tensile tests may be performed to qualify the material. The results of each of these tests shall satisfy the required yield strength.

G.5.2.2.2 Material Grade Qualification Testing

S_e at temperature shall be minimum yield strength of the material strength class of Table 8, reduced by the amount of de-rating of yield strength at the elevated temperature compared to the measured yield strength at a temperature between 4 °C and 50 °C (between 40 °F and 120 °F).

Qualification testing shall be performed on a minimum of five heats of the material grade (same UNS alloy number or individual material composition and same heat-treat condition) for a particular strength class at elevated temperature and at room temperature. In addition, the room-temperature and elevated-temperature tensile specimens shall be obtained from the required location within the same QTC for a given heat. The yield strength values, E_{ty} and R_{ty} , shall each be averaged for use in determining the amount of yield de-rating at a particular temperature.

The yield reduction ratio at temperature, Y_r , shall be calculated as given in Equation (G.1):

$$Y_r = \frac{E_{ty}}{R_{ty}} \quad (G.1)$$

where

R_{ty} is the room-temperature yield strength (measured, 5 heats minimum);

E_{ty} is the elevated-temperature yield strength (measured, 5 heats minimum).

The elevated-temperature yield strength, S_e , is then calculated as given in Equation (G.2):

$$S_e = Y_r S_y \quad (G.2)$$

where

S_y is the minimum specified room-temperature yield strength for the material.

The elevated-temperature tensile data along with the room-temperature data for the material grade shall be contained in a material qualification file for each material grade, and it is not necessary that this test be performed on a heat lot basis.

G.5.2.3 Reference Sources

G.5.2.3.1 API 17TR8

Technical Report API 17TR8 provides guidance regarding HPHT applications that are beyond the scope of this specification.

G.5.2.3.2 API TR 6AF1

The material may be de-rated using the de-rating factors, Y_r , shown in Table G.3, which, in part, are taken from API 6AF1, Table 1.

G.5.2.3.3 ASME Boiler and Pressure Vessel Code

S_e can be found for some materials in ASME *BPVC*:2004 with 2005 and 2006 addenda, Section II, Part D, Table Y-1.

Table G.3—Optional Material De-rating Factors for Elevated Temperature

Material	De-rating Factor, Y_r	
	180 °C (350 °F)	345 °C (650 °F)
Carbon and low-alloy steels	0.85	0.75
Martensitic, ferritic, and precipitation-hardened stainless steels	0.85	0.75
Austenitic and duplex stainless steels	0.80	0.73
Corrosion-resistant alloys (CRAs)	0.95	0.85
Caution—This table does not constitute a recommendation of the use of any specific alloy at high temperature. Some materials are embrittled after repeated or prolonged exposure to elevated temperatures. Care should be taken when choosing a material for use at temperatures permitted by temperature classes X and Y in Table G.1.		

G.5.2.3.4 Other Data

The material may be de-rated using the de-rating factors, Y_r , shown in Table G.4.

Table G.4—Optional Material De-rating Factors for Elevated Temperature

Material	De-rating Factor, Y_r		
	149 °C (300 °F)	177 °C (350 °F)	232 °C (450 °F)
25 Cr super duplex	0.81	0.78	0.73
ASTM 453/453M Gr 660D (UNS S66286)	0.97	0.96	0.94
718 (as per API 6ACRA) (UNS N07718)	0.94	0.93	0.91
925 (UNS N09925)	0.92	0.92	0.90
AISI 4130	0.91	0.90	0.88
AISI 8630 (Modified)	0.92	0.90	0.87
2-1/4 Cr 1 Mo (UNS K21590)	0.92	0.91	0.89
AISI 4140	0.92	0.90	0.88
AISI 410 SS (UNS S41000)	0.91	0.90	0.88
F6NM (UNS S42400)	0.92	0.91	0.88
725/625 Plus (UNS N07725 and UNS N07716)	0.93	0.92	0.89
FOOTNOTES ^a Section size affects hardenability. CAUTION—This table does not constitute a recommendation of the use of any specific alloy at high temperature. Some materials are embrittled after repeated or prolonged exposure to elevated temperatures. Care should be taken when choosing a material for use at temperatures permitted by temperature classes X and Y in Table G.1.			

Annex H (informative)

Recommended Assembly of Closure Bolting

H.1 Lubrication

H.1.1 Gasket Lubrication

Ring gaskets installed in 6B or 6BX flanged and studded connectors should be lightly lubricated prior to assembly. Appropriate lubricants include mineral-base oil (20 W or higher), synthetic motor oil (5W or higher) or a general-purpose grease suitable for high-pressure metal-to-metal application. Greases or thread compounds with metallic additives shall not be used. Lubricant, if applied, shall be applied as a thin film, never in sufficient amount to have any possibility of filling the grooves.

This is recommended to avoid galling of the gasket and/or ring groove mating seal surfaces and is particularly important for stainless steel or CRA ring grooves. The connections are designed to achieve a mechanical preload between the gasket OD seal surface and the outside flank of the groove on initial assembly. To ensure a reliable metal seal, the 6B and 6BX connector designs produce contact bearing stresses at the 23° mating surfaces that are many times higher than the rated working pressure.

As the flange bolting is made up, the narrow 23° gasket seal surfaces must slide along the 23° flanks of the grooves, under very high load. Without lubrication, this could cause damage to the seal surfaces. If the connection is disassembled and re-assembled for service, lubrication of the metal gasket for assembly is essential to allow repeated use of the equipment without repair of the ring grooves. Because of the high bearing stress, the film thickness of lubricant initially applied to the gasket is not critical.

H.1.2 Bolting Lubrication

To achieve the desired tensile preload in the studs, the stud threads and the bearing face of the nuts should be well lubricated. Paint thickness should be minimal (e.g. primer coat only) in the bearing areas of the flange back-face where the nuts contact it. Multipart coating systems have been known to creep over time under the high crushing loads of the nuts, resulting in leakage.

H.2 Bolt Tightening Pattern

Flange bolting shall be tightened gradually, repeatedly working around the bolt pattern in a “crisscross” or “star” pattern. As an alternative, multihead tools may be used per the manufacturer’s procedures.

NOTE Examples of bolt make-up sequence are shown in Figure H.1 and in ASME PCC-1.

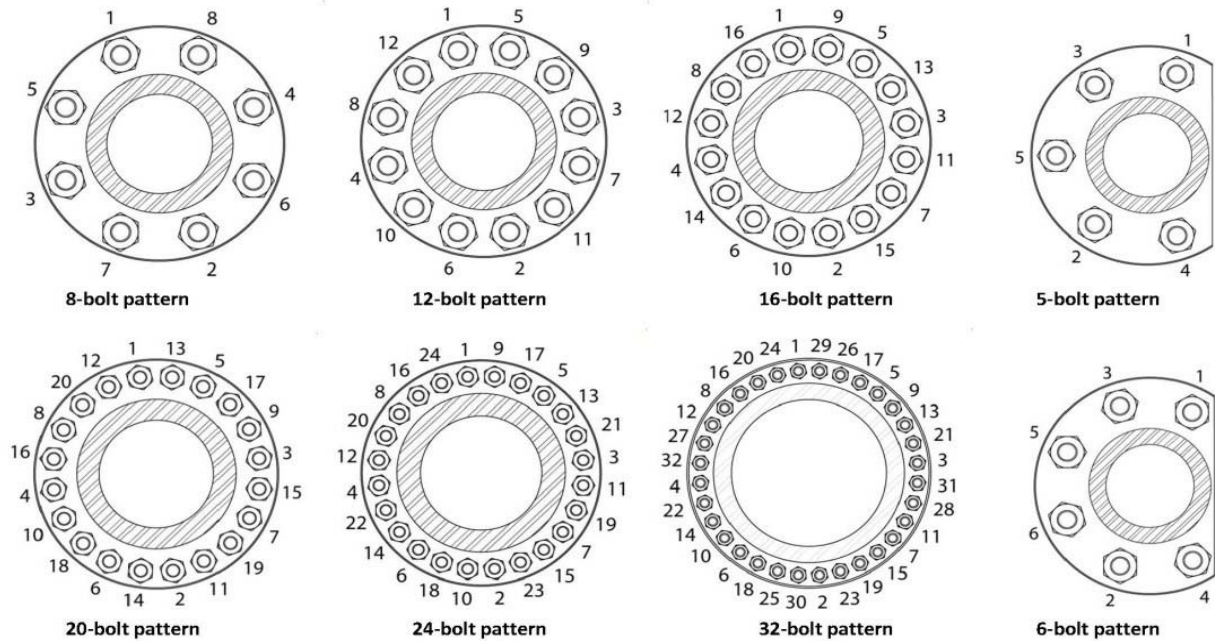

Figure H.1—Recommended Bolting Make-up Patterns

H.3 Recommended Make-up Torque

H.3.1 General Principles

It has been shown that the torque values given in Table H.1 and Table H.2 are acceptable values for use in type 6B and 6BX flanges in some applications.

NOTE Refer to API TR 6AF, API TR 6AF1, or API TR 6AF2 for data on the effects on flange performance of bolt preload stress and other factors.

It should be recognized that torque applied to a nut is only one of several ways to approximate the tension and stress in a fastener.

Table H.1 and Table H.2 are based on calculations that assume certain friction coefficients for the friction between the studs and nuts, and between the nuts and the flange face.

Some factors that affect the relationship between nut torque and stud stress are as follows:

- thread dimensions and form;
- surface finish of studs, nuts, and flange face;
- degree of parallelism between nut face and flange face;
- type of lubrication and coatings of the threads and nut bearing surface areas.

Table H.1—Recommended Torques for Flange Bolting (SI Units)

Stud Diameter	Threads per in.	Studs with $S_y = 550$ MPa Bolt Stress Equal to 275 MPa			Studs with $S_y = 720$ MPa Bolt Stress Equal to 360 MPa			Studs with $S_y = 655$ MPa Bolt Stress Equal to 327.5 MPa		
		Tension F kN	Torque $f = 0.07$ N-m	Torque $f = 0.13$ N-m	Tension F kN	Torque $f = 0.07$ N-m	Torque $f = 0.13$ N-m	Tension F kN	Torque $f = 0.07$ N-m	Torque $f = 0.13$ N-m
D in.	N 1/in.									
0.500	13	25	36	61	33	48	80	—	—	—
0.625	11	40	70	118	52	92	155	—	—	—
0.750	10	59	122	206	78	160	270	—	—	—
0.875	9	82	193	328	107	253	429	—	—	—
1.000	8	107	288	488	141	376	639	—	—	—
1.125	8	140	413	706	184	540	925	—	—	—
1.250	8	177	569	981	232	745	1285	—	—	—
1.375	8	219	761	1320	286	996	1727	—	—	—
1.500	8	265	991	1727	346	1297	2261	—	—	—
1.625	8	315	1263	2211	412	1653	2894	—	—	—
1.750	8	369	1581	2777	484	2069	3636	—	—	—
1.875	8	428	1947	3433	561	2549	4493	—	—	—
2.000	8	492	2366	4183	644	3097	5476	—	—	—
2.250	8	631	3375	5997	826	4418	7851	—	—	—
2.500	8	788	4635	8271	1032	6068	10,828	—	—	—
2.625	8	—	—	—	—	—	—	1040	6394	11,429
2.750	8	—	—	—	—	—	—	1146	7354	13,168
3.000	8	—	—	—	—	—	—	1375	9555	17,156
3.250	8	—	—	—	—	—	—	1624	12,154	21,878
3.750	8	—	—	—	—	—	—	2185	18,685	33,766
3.875	8	—	—	—	—	—	—	2338	20,620	37,293
4.000	8	—	—	—	—	—	—	2496	22,683	41,057

Table H.2—Recommended Torques for Flange Bolting (USC Units)

Stud Diameter <i>D</i> in.	Threads per in. <i>N</i> 1/in.	Studs with $S_y = 80$ ksi Bolt Stress Equal to 40 ksi			Studs with $S_y = 105$ ksi Bolt Stress Equal to 52.5 ksi			Studs with $S_y = 95$ ksi Bolt Stress Equal to 47.5 ksi		
		Tension <i>F</i> lbf	Torque $f = 0.07$ ft-lbf	Torque $f = 0.13$ ft-lbf	Tension <i>F</i> lbf	Torque $f = 0.07$ ft-lbf	Torque $f = 0.13$ ft-lbf	Tension <i>F</i> lbf	Torque $f = 0.07$ ft-lbf	Torque $f = 0.13$ ft-lbf
0.500	13	5676	27	45	7,450	35	59	—	—	—
0.625	11	9040	52	88	11,865	68	115	—	—	—
0.750	10	13,378	90	153	17,559	118	200	—	—	—
0.875	9	18,469	143	243	24,241	188	319	—	—	—
1.000	8	24,230	213	361	31,802	279	474	—	—	—
1.125	8	31,618	305	523	41,499	401	686	—	—	—
1.250	8	39,988	421	726	52,484	553	953	—	—	—
1.375	8	49,340	563	976	64,759	739	1281	—	—	—
1.500	8	59,674	733	1278	78,322	962	1677	—	—	—
1.625	8	70,989	934	1635	93,173	1226	2146	—	—	—
1.750	8	83,286	1169	2054	109,313	1534	2696	—	—	—
1.875	8	96,565	1440	2539	126,741	1890	3332	—	—	—
2.000	8	110,825	1750	3094	145,458	2297	4061	—	—	—
2.250	8	142,292	2496	4436	186,758	3276	5822	—	—	—
2.500	8	177,685	3429	6118	233,212	4500	8030	—	—	—
2.625	8	—	—	—	—	—	—	233,765	4716	8430
2.750	8	—	—	—	—	—	—	257,694	5424	9712
3.000	8	—	—	—	—	—	—	309,050	7047	12,654
3.250	8	—	—	—	—	—	—	365,070	8965	16,136
3.750	8	—	—	—	—	—	—	491,099	13,782	24,905
3.875	8	—	—	—	—	—	—	525,521	15,208	27,506
4.000	8	—	—	—	—	—	—	561,108	16,730	30,282

Two coefficients of friction are used in the tables. A coefficient of friction of 0.13 approximates the friction with threads and nut bearing surfaces being bare metal, well lubricated. For applications above 260 °C (500 °F), lubrication shall not contain lead, tin, antimony or bismuth. A coefficient of friction of 0.07 approximates threads and nut face coated with fluoropolymer material.

Lubricants, surface finishes, etc., may influence the accuracy of the actual bolt tension when measuring torque. Therefore, the torque values listed in Table H.1 and Table H.2 are provided only as an informative guide. The torque and the make-up practices employed should be verified by the manufacturer.

The tables show material properties equivalent to ASTM A193/A193M grades B7 and B7M, which are the most commonly used. Values of torque for materials having other strength levels may be obtained by multiplying the tabulated torque value by the ratio of the new material's yield strength to the tabulated material's yield strength.

H.3.2 Equations

For the values in Table H.1 and Table H.2, the stress area, A_s , expressed in square millimeters (square inches), is calculated as given in Equation (H.1); the force per stud, F , expressed in newtons (pound-force), is calculated as given in Equation (H.2); the torque, τ , is calculated as given in Equation (H.3):

$$A_s = \frac{1}{4} \times \pi [D - (0.9743 \times P)]^2 \quad (\text{H.1})$$

$$F = \sigma A_s \quad (\text{H.2})$$

$$\tau = \frac{F \cdot E \left[P + \frac{\pi f \cdot E}{\cos(\pi/6)} \right]}{2 \left[\pi E - \frac{P \cdot f}{\cos(\pi/6)} \right]} + F \cdot f \left[\frac{H + D + K}{4} \right] \quad (\text{H.3})$$

where

- D is the thread major diameter, expressed in millimeters (inches);
- E is the pitch diameter of thread, expressed in millimeters (inches);
- f is the friction coefficient;
- H is the hex size (nut), equal to $1.5 D + 3.175 \text{ mm}$ (0.125 in.);
- K is the nut internal chamfer, equal to 3.175 mm (0.125 in.);
- P is the thread pitch, equal to $\frac{1}{\text{number of threads per unit length}}$, expressed in millimeters (inches);
- σ is the stress in the stud/bolt.

The torque obtained using units of millimeters and newtons is in units of newton-millimeters and is divided by 1000 to obtain newton-meters (N-m). The torque obtained using units of inches and pounds is in units of inches-pound-force and is divided by 12 to obtain foot-pound-force (ft-lbf).

NOTE The stresses in these calculations are based on stress area, and not on the minimum cross-sectional area of the bolting as required for stress calculations in 8.1.

H.3.3 Recommendation for Specific Flanges

The following flanges should not be assembled with a make-up torque that would produce a bolt stress greater than 275 MPa (40,000 psi):

- $13^{5/8}$ in.: 13.8 MPa (2000 psi);
- $16^{3/4}$ in.: 13.8 MPa (2000 psi);
- $21^{1/4}$ in.: 13.8 MPa (2000 psi);
- $13^{5/8}$ in.: 20.7 MPa (3000 psi).

Annex I (informative)

Recommended Bolt Lengths

I.1 Calculation

I.1.1 General

NOTE Figure I.1 and Figure I.2 are provided for illustration of flange bolting and studded bolting configurations, respectively.

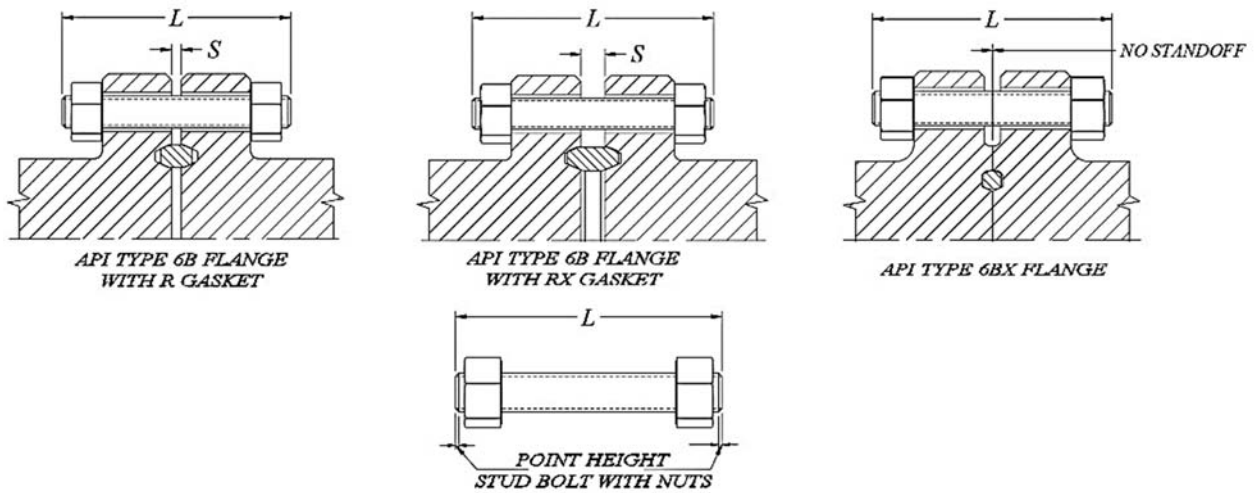

Figure I.1—Flange Bolting Configurations

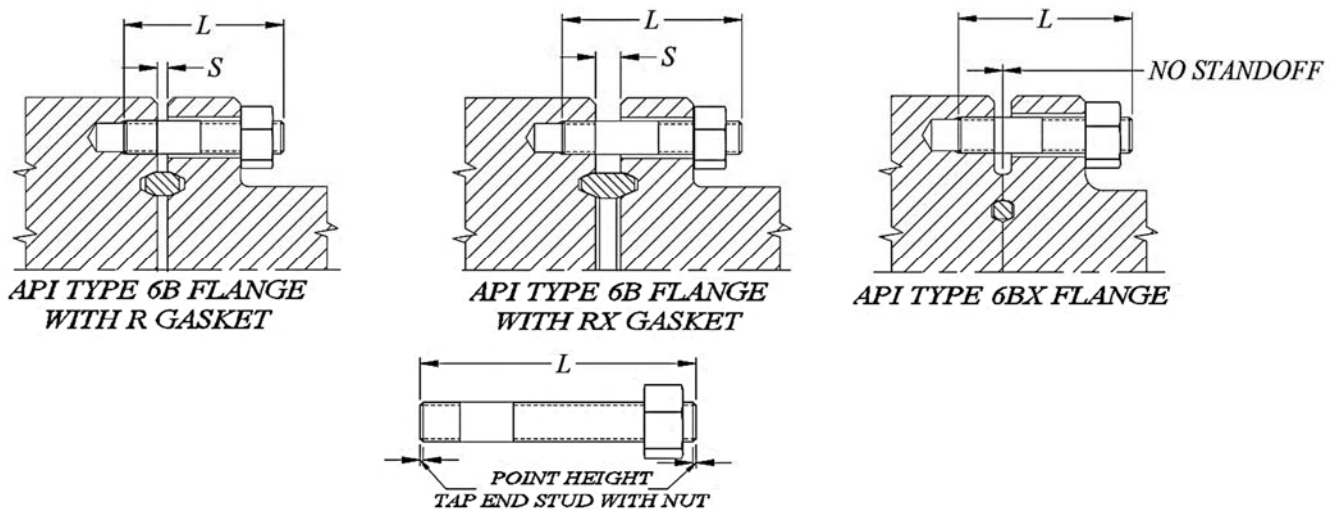

Figure I.2—Studded Bolting Configurations

Equation (I.1) is used in establishing stud bolt lengths listed in Table I.1 and Table I.2 and is included here for the convenience of industry. Length shown in tables results from rounding as specified in I.1.2.

$$L = 2(T + t + d) + S + 2(P) \quad (I.1)$$

where

L is calculated stud bolt length;

T is total flange thickness;

t is plus tolerance for flange thickness;

d is heavy hex nut thickness (equals nominal bolt diameter; see ASME B18.2.2);

S is flange face standoff; $S = 0$ for BX assemblies [see Table D.9 (gasket)/Table E.9 (gasket)—Type R and Table D.10 (gasket)/Table E.10 (gasket)—Type RX];

P is maximum end point height (1.5 x pitch of thread).

I.1.2 Rounding Off Procedure

0.010 in. (or more) greater than any $\frac{1}{4}$ in. increment, round off upward to the next $\frac{1}{4}$ in. increment; if less than 0.010 in., round off downward to the next $\frac{1}{4}$ in. increment.

I.1.3 End Point-height of Stud Bolts

The end point is the end portion of a stud bolt beyond the complete thread and may be chamfered, rounded, or sheared. The maximum height of each end point shall be 1.5 x pitch of thread.

I.1.4 Flange Face Standoff Values, S

The approximate distance between faces of made-up flanges, S (see Figure I.1) is given in Table D.9/Table E.9—Type R gasket and Table D.10/Table E.10—Type RX gasket.

Table I.1—Stud Bolt Length Table for 6B Flange Connectors with “R” and “RX” Gaskets

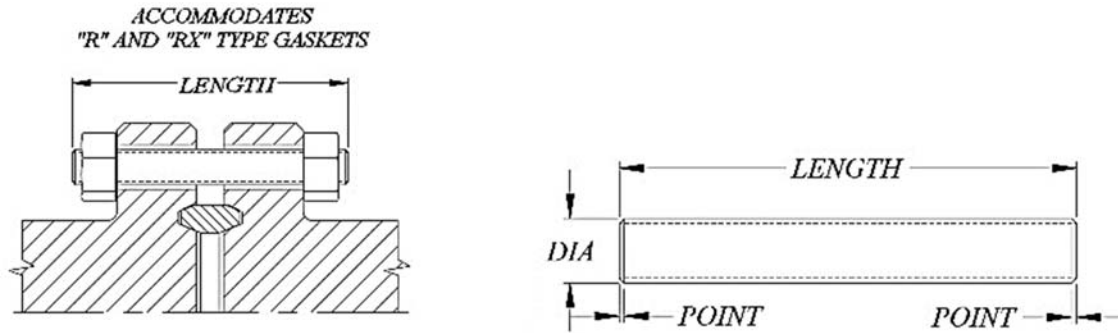

$$\text{LENGTH} = 2(T + t + d) + S + 2(P)$$

- T* is total flange thickness;
- t* is plus tolerance for flange thickness;
- d* is heavy hex nut thickness;
- S* is flange face standoff (with “RX” gasket);
- P* is point max. (1.5 x pitch).

Dimensions in inches

Flange Size and Pressure	Bolt Size and Thread	Length*	Flange Size and Pressure	Bolt Size and Thread	Length*
2 ¹ / ₁₆ 2000	5/8-11 UNC	5.000	7 ¹ / ₁₆ 2000	1-8 UNC	7.500
2 ¹ / ₁₆ 3000	7/8-9 UNC	6.500	7 ¹ / ₁₆ 3000	1 ¹ / ₈ -8 UN	8.500
2 ¹ / ₁₆ 5000	7/8-9 UNC	6.500	7 ¹ / ₁₆ 5000	1 ³ / ₈ -8 UN	11.250
2 ⁹ / ₁₆ 2000	3/4-10 UNC	5.500	9 2000	1 ¹ / ₈ -8 UN	8.500
2 ⁹ / ₁₆ 3000	1-8 UNC	7.000	9 3000	1 ³ / ₈ -8 UN	9.500
2 ⁹ / ₁₆ 5000	1-8 UNC	7.000	9 5000	1 ⁵ / ₈ -8 UN	12.500
3 ¹ / ₈ 2000	3/4-10 UNC	5.750	11 2000	1 ¹ / ₄ -8 UN	9.250
3 ¹ / ₈ 3000	7/8-9 UNC	6.500	11 3000	1 ³ / ₈ -8 UN	10.000
3 ¹ / ₈ 5000	1 ¹ / ₈ -8 UN	7.750	11 5000	1 ⁷ / ₈ -8 UN	14.250
4 ¹ / ₁₆ 2000	7/8-9 UNC	6.500	13 ⁵ / ₈ 2000	1 ¹ / ₄ -8 UN	9.500
4 ¹ / ₁₆ 3000	1 ¹ / ₈ -8 UN	7.500	13 ⁵ / ₈ 3000	1 ³ / ₈ -8 UN	10.750
4 ¹ / ₁₆ 5000	1 ¹ / ₄ -8 UN	8.500	16 ³ / ₄ 2000	1 ¹ / ₂ -8 UN	10.750
5 ¹ / ₈ 2000	1-8 UNC	7.250	16 ³ / ₄ 3000	1 ⁵ / ₈ -8 UN	12.250
5 ¹ / ₈ 3000	1 ¹ / ₄ -8 UN	8.250	21 ¹ / ₄ 2000	1 ⁵ / ₈ -8 UN	12.250
5 ¹ / ₈ 5000	1 ¹ / ₂ -8 UN	10.500	20 ³ / ₄ 3000	2-8 UN	15.000

FOOTNOTES

* Tolerance on bolt length:
 +0.125/-0 in. for lengths up to 12 in.
 +0.250/-0 in. for lengths over 12 in.

Table I.2—Stud Bolt Length Table for 6BX Flange Connectors

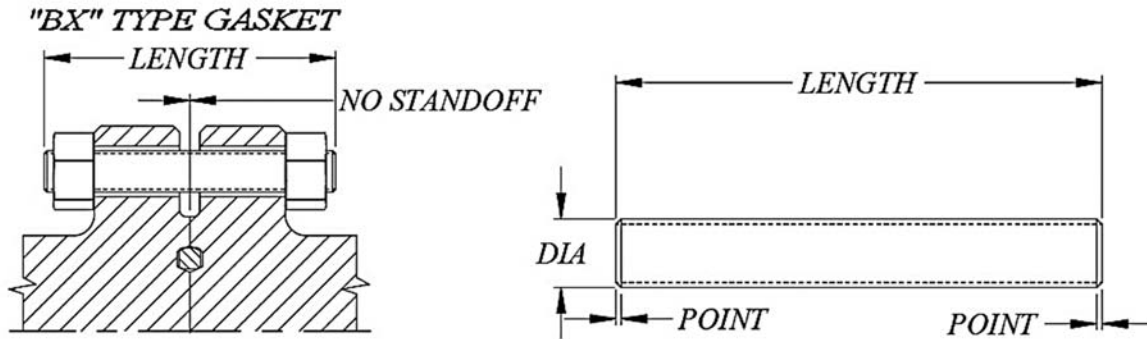

$LENGTH = 2(T + t + d) + S + 2(P)$

- T* is total flange thickness;
- t* is plus tolerance for flange thickness;
- d* is heavy hex nut thickness;
- S* is flange face standoff (NOTE *S* = 0 for BX connection which has no standoff height);
- P* is point max. (1.5 x pitch).

Dimensions in inches

Flange Size and Pressure	Bolt Size and Thread	Length*	Flange Size and Pressure	Bolt Size and Thread	Length*
1 ³ / ₁₆ 10,000	3/4-10 UNC	5.500	11 10,000	1 ³ / ₄ -8 UN	15.250
1 ³ / ₁₆ 15,000	7/8-9 UNC	6.000	11 15,000	2-8 UN	19.500
1 ³ / ₁₆ 20,000	1-8 UNC	7.750	11 20,000	2 ³ / ₄ -8 UN	23.750
2 ¹ / ₁₆ 10,000	3/4-10 UNC	5.500	13 ⁵ / ₈ 5000	1 ⁵ / ₈ -8 UN	12.750
2 ¹ / ₁₆ 15,000	7/8-9 UNC	6.500	13 ⁵ / ₈ 10,000	1 ⁷ / ₈ -8 UN	17.750
2 ¹ / ₁₆ 20,000	1 ¹ / ₈ -8 UN	8.500	13 ⁵ / ₈ 15,000	2 ¹ / ₄ -8 UN	21.250
2 ⁹ / ₁₆ 10,000	7/8-9 UNC	6.500	13 ⁵ / ₈ 20,000	3-8 UN	29.750
2 ⁹ / ₁₆ 15,000	1-8 UN	7.250	16 ³ / ₄ 5000	1 ⁷ / ₈ -8 UN	14.750
2 ⁹ / ₁₆ 20,000	1 ¹ / ₄ -8 UN	9.500	16 ³ / ₄ 10,000	1 ⁷ / ₈ -8 UN	17.750
3 ¹ / ₁₆ 10,000	1-8 UNC	7.250	18 ³ / ₄ 5000	2-8 UN	17.750
3 ¹ / ₁₆ 15,000	1 ¹ / ₈ -8 UN	8.000	18 ³ / ₄ 10,000	2 ¹ / ₄ -8 UN	22.750
3 ¹ / ₁₆ 20,000	1 ³ / ₈ -8 UN	10.250	18 ³ / ₄ 15,000	3-8 UN	26.750
4 ¹ / ₁₆ 10,000	1 ¹ / ₈ -8 UN	8.500	21 ¹ / ₄ 5000	2-8 UN	19.000
4 ¹ / ₁₆ 15,000	1 ³ / ₈ -8 UN	9.750	21 ¹ / ₄ 10,000	2 ¹ / ₂ -8 UN	24.750
4 ¹ / ₁₆ 20,000	1 ³ / ₄ -8UN	12.500	26 ³ / ₄ 2000	1 ³ / ₄ -8 UN	14.250
5 ¹ / ₈ 10,000	1 ¹ / ₈ -8 UN	9.250	26 ³ / ₄ 3000	2-8 UN	17.500
5 ¹ / ₈ 15,000	1 ¹ / ₂ -8 UN	11.500	30 2000	1 ⁵ / ₈ -8 UN	14.500
7 ¹ / ₁₆ 10,000	1 ¹ / ₂ -8 UN	11.750	30 3000	1 ⁷ / ₈ -8 UN	17.750
7 ¹ / ₁₆ 15,000	1 ¹ / ₂ -8 UN	13.000			
7 ¹ / ₁₆ 20,000	2-8 UN	17.750			
9 10,000	1 ¹ / ₂ -8 UN	13.500			
9 15,000	1 ⁷ / ₈ -8 UN	16.000			
9 20,000	2 ¹ / ₂ -8UN	21.750			

FOOTNOTES

* Tolerance on bolt length:
 +0.125/-0 in. for lengths up to 12 in.
 +0.250/-0 in. for lengths over 12 in.

I.2 Method of Calculating Tap End Stud Lengths for Type 6B and 6BX Flanges

I.2.1 Calculation

Equation (I.2) is used in establishing tap end stud lengths listed in Table I.3, Table I.4, Table I.5, and Table I.6 and is included here for convenience of industry. Length shown in tables results from rounding as specified in I.2.2.

$$L = T + t + d + S + P + TL + RF \quad (I.2)$$

where

L is calculated tap end stud length;

T is total flange thickness;

t is plus tolerance for flange thickness;

d is heavy hex nut thickness (equals nominal bolt diameter; see ASME B18.2.2);

S is flange face standoff; $S = 0$ for BX assemblies [see Table D.8 (groove)/Table E.8 (groove) and Table D.9 (gasket)/Table E.9 (gasket)—Type R and Table D.10 (gasket)/Table E.10 (gasket)—Type RX];

P is maximum end point height (1.5 x pitch of thread);

TL is tap end thread length, maximum [(one diameter + 1.5 pitch) + $1/16$];

RF add amount of raised face present on studded flanges, if not omitted, to the length of studs in table.

I.2.2 Rounding off Procedure

Add $1/16$ in. to the calculated length and then round up to the next $1/8$ in. increment after this addition. This rounding procedure allows for variation in stud installation methods and ensures sufficient extension for full nut engagement.

I.2.3 Endpoint Height of Tap End Studs

The endpoint is the end portion of a stud bolt beyond the complete thread and may be chamfered, rounded, or sheared. The maximum height of each endpoint shall be 1.5 x pitch of thread.

I.2.4 Tap End Thread Length

One diameter of tap end stud + 1.5 pitch of thread, with a tolerance of $+1/16/-0$ (this includes point height).

I.2.5 Nut End Thread Length

2.5 x diameter of tap end stud minimum. However, if necessary, this length shall be limited to provide minimum unthreaded portion equal to one thread pitch between the tap end threads and nut end threads.

I.2.6 Flange Face Standoff Values, S

The approximate distance between faces of made-up flanges, S (see Figure I.2) is given in Table D.9/Table E.9—Type R gasket and Table D.10/Table E.10—Type RX gasket.

Table I.3—Tap End Stud Length Table for 6B Studded Flange Connectors with “R” and “RX” Gaskets

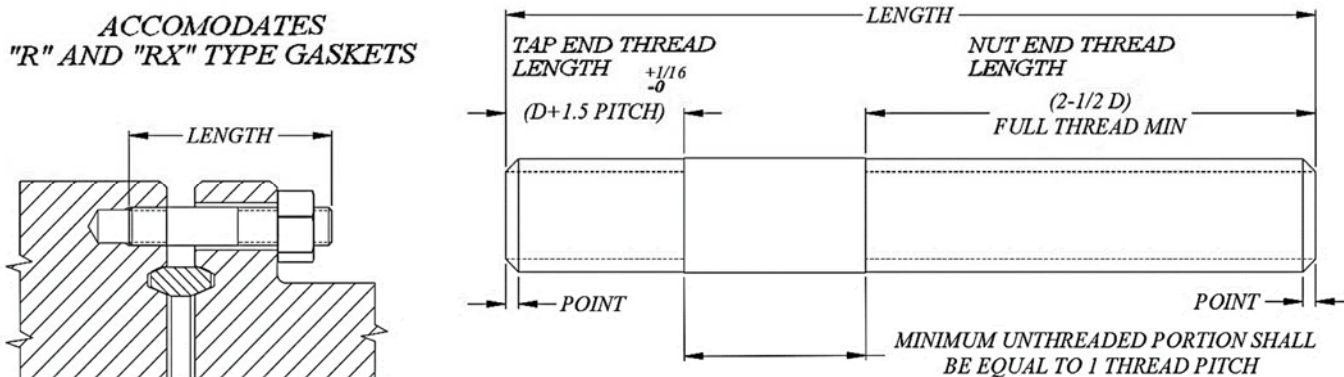

$$LENGTH = T + t + d + S + P + TL + RF$$

T is total flange thickness;

t is plus tolerance for flange thickness;

d is heavy hex nut thickness;

S is flange face standoff (with “RX” gasket);

P is point, max. (1.5 x pitch);

TL is tap end thread length, max. [(one diameter + 1.5 pitch) + 1/16];

RF add amount of raised face present on studded flanges, if not omitted, to the length of studs in table.

Dimensions in inches

Flange Size and Pressure	Bolt Size and Thread	Tap End Length*	Nut End Length	Length**	Flange Size and Pressure	Bolt Size and Thread	Tap End Length*	Nut End Length	Length**
2 ¹ / ₁₆ 2000	5/8-11 UNC	0.761	1.563	3.625	7 ¹ / ₁₆ 2000	1-8 UNC	1.188	2.500	5.375
2 ¹ / ₁₆ 3000	7/8-9 UNC	1.042	2.188	4.625	7 ¹ / ₁₆ 3000	1 ¹ / ₈ -8 UN	1.313	2.813	5.875
2 ¹ / ₁₆ 5000	7/8-9 UNC	1.042	2.188	4.625	7 ¹ / ₁₆ 5000	1 ³ / ₈ -8 UN	1.563	3.438	7.500
2 ⁹ / ₁₆ 2000	3/4-10 UNC	0.900	1.875	4.000	9 2000	1 ¹ / ₈ -8 UN	1.313	2.813	5.875
2 ⁹ / ₁₆ 3000	1-8 UNC	1.188	2.500	5.125	9 3000	1 ³ / ₈ -8 UN	1.563	3.438	6.750
2 ⁹ / ₁₆ 5000	1-8 UNC	1.188	2.500	5.125	9 5000	1 ⁵ / ₈ -8 UN	1.813	4.063	8.500
3 ¹ / ₈ 2000	3/4-10 UNC	0.900	1.875	4.125	11 2000	1 ¹ / ₄ -8 UN	1.438	3.125	6.500
3 ¹ / ₈ 3000	7/8-9 UNC	1.042	2.188	4.625	11 3000	1 ³ / ₈ -8 UN	1.563	3.438	7.000
3 ¹ / ₈ 5000	1 ¹ / ₈ -8 UN	1.313	2.813	5.625	11 5000	1 ⁷ / ₈ -8 UN	2.063	4.688	9.625
4 ¹ / ₁₆ 2000	7/8-9 UNC	1.042	2.188	4.625	13 ⁵ / ₈ 2000	1 ¹ / ₄ -8 UN	1.438	3.125	6.625
4 ¹ / ₁₆ 3000	1 ¹ / ₈ -8 UN	1.313	2.813	5.500	13 ⁵ / ₈ 3000	1 ³ / ₈ -8 UN	1.563	3.438	7.375
4 ¹ / ₁₆ 5000	1 ¹ / ₄ -8 UN	1.438	3.125	6.125	16 ³ / ₄ 2000	1 ¹ / ₂ -8 UN	1.688	3.750	7.500
5 ¹ / ₈ 2000	1-8 UNC	1.188	2.500	5.250	16 ³ / ₄ 3000	1 ⁵ / ₈ -8 UN	1.813	4.063	8.375
5 ¹ / ₈ 3000	1 ¹ / ₄ -8 UN	1.438	3.125	6.000	21 ¹ / ₄ 2000	1 ⁵ / ₈ -8 UN	1.813	4.063	8.375
5 ¹ / ₈ 5000	1 ¹ / ₂ -8 UN	1.688	3.750	7.375	20 ³ / ₄ 3000	2-8 UN	2.188	5.000	10.125

FOOTNOTES

* Tolerance on tap end thread length: +0.063/-0 in.

** Tolerance on tap end stud length: +0.125/-0 in.

Table I.4—Tap End Stud Length Table for 6BX Studded Flange Connectors

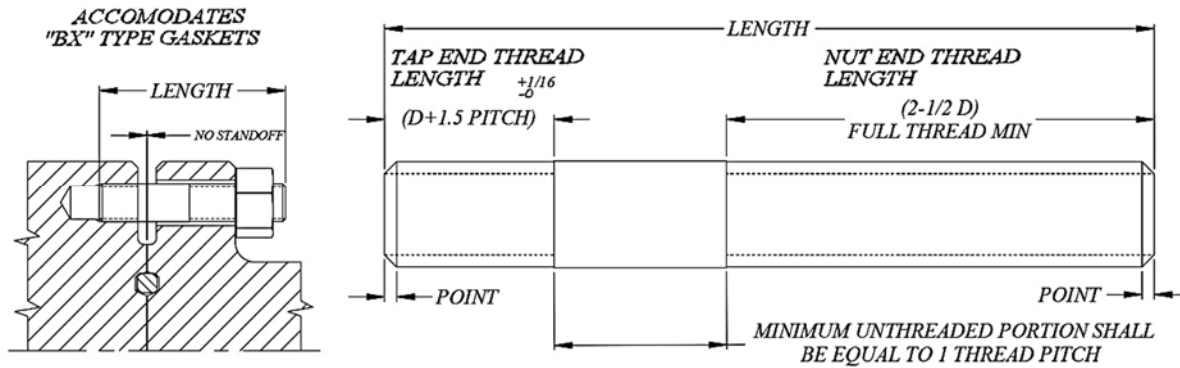

$$LENGTH = T + t + d + S + P + TL + RF$$

- T is total flange thickness;
- t is plus tolerance for flange thickness;
- d is heavy hex nut thickness;
- S is flange face standoff;
- P is point, max. (1.5 x pitch);
- TL is tap end thread length, max. [(one diameter + 1.5 pitch) + 1/16];
- RF add amount of raised face present on studded flanges, if not omitted, to the length of studs in table.

Dimensions in inches

Flange Size and Pressure	Bolt Size and Thread	Tap End Length*	Nut End Length	Length**	Flange Size and Pressure	Bolt Size and Thread	Tap End Length*	Nut End Length	Length**
1 13/16 10,000	3/4-10 UNC	0.900	1.875	3.750	11 10,000	1 3/4-8 UN	1.938	4.375	9.750
1 13/16 15,000	7/8-9 UNC	1.042	2.188	4.125	11 15,000	2-8 UN	2.188	5.000	12.000
1 13/16 20,000	1-8 UNC	1.188	2.500	5.125	11 20,000	2 3/4-8 UN	2.938	6.875	15.000
2 1/16 10,000	3/4-10 UNC	0.900	1.875	3.875	13 5/8 5000	1 5/8-8 UN	1.813	4.063	8.375
2 1/16 15,000	7/8-9 UNC	1.042	2.188	4.375	13 5/8 10,000	1 7/8-8 UN	2.063	4.688	11.000
2 1/16 20,000	1 1/8-8 UN	1.313	2.813	5.750	13 5/8 15,000	2 1/4-8 UN	2.438	5.625	13.250
2 9/16 10,000	7/8-9 UNC	1.042	2.188	4.375	13 5/8 20,000	3-8 UN	3.188	7.500	18.125
2 9/16 15,000	1-8 UNC	1.188	2.500	4.875	16 3/4 5000	1 7/8-8 UN	2.063	4.688	9.500
2 9/16 20,000	1 1/4-8 UN	1.438	3.125	6.250	16 3/4 10,000	1 7/8-8 UN	2.063	4.688	11.000
3 1/16 10,000	1-8 UNC	1.188	2.500	5.000	18 3/4 5000	2-8 UN	2.188	5.000	11.250
3 1/16 15,000	1 1/8-8 UN	1.313	2.813	5.500	18 3/4 10,000	2 1/4-8 UN	2.438	5.625	14.000
3 1/16 20,000	1 3/8-8 UN	1.563	3.438	6.750	18 3/4 15,000	3-8 UN	3.188	7.500	16.750
4 1/16 10,000	1 1/8-8 UN	1.313	2.813	5.750	21 1/4 5000	2-8 UN	2.188	5.000	11.750
4 1/16 15,000	1 3/8-8 UN	1.563	3.438	6.500	21 1/4 10,000	2 1/2-8 UN	2.688	6.250	15.125
4 1/16 20,000	1 3/4-8 UN	1.938	4.375	8.375	26 3/4 2000	1 3/4-8 UN	1.938	4.375	9.125
5 1/8 10,000	1 1/8-8 UN	1.313	2.813	6.000	26 3/4 3000	2-8 UN	2.188	5.000	11.000
5 1/8 15,000	1 1/2-8 UN	1.688	3.750	7.625	30 2000	1 5/8-8 UN	1.813	4.063	9.250
7 1/16 10,000	1 1/2-8 UN	1.688	3.750	7.750	30 3000	1 7/8-8 UN	2.063	4.688	11.000
7 1/16 15,000	1 1/2-8 UN	1.688	3.750	8.375					
7 1/16 20,000	2-8 UN	2.188	5.000	11.125					
9 10,000	1 1/2-8 UN	1.688	3.750	8.500					
9 15,000	1 7/8-8 UN	2.063	4.688	10.125					
9 20,000	2 1/2-8 UN	2.688	6.250	13.750					

FOOTNOTES

- * Tolerance on tap end thread length: + 0.063/-0 in.
- ** Tolerance on tap end stud length: + 0.125/-0 in.

Table I.5—Stud Bolt Length Table for 6B Flange Connectors with “R” Gaskets (USC Units)

*ACCOMMODATES
"R" TYPE GASKETS ONLY*

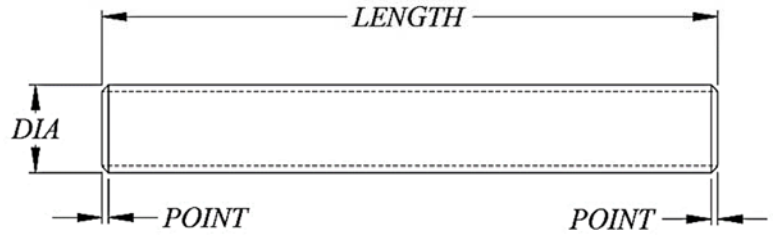
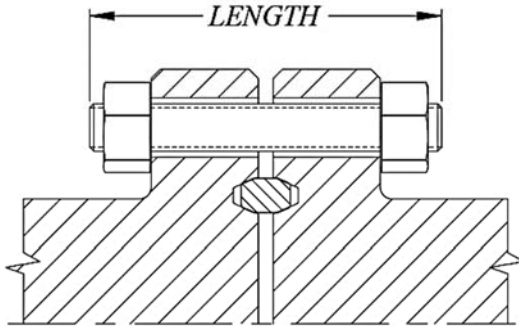

$$LENGTH = 2(T + t + d) + S + 2(P)$$

- T* is total flange thickness;
- t* is plus tolerance for flange thickness;
- d* is heavy hex nut thickness;
- S* is flange face standoff (with “R” gasket);
- P* is point max. (1.5 x pitch).

Dimensions in inches

Flange Size and Pressure	Bolt Size and Thread	Length*	Flange Size and Pressure	Bolt Size and Thread	Length*
2 ¹ / ₁₆ 2000	5/8-11 UNC	4.750	7 ¹ / ₁₆ 2000	1-8 UNC	7.250
2 ¹ / ₁₆ 3000	7/8-9 UNC	6.250	7 ¹ / ₁₆ 3000	1 ¹ / ₈ -8 UN	8.250
2 ¹ / ₁₆ 5000	7/8-9 UNC	6.250	7 ¹ / ₁₆ 5000	1 ³ / ₈ -8 UN	11.000
2 ⁹ / ₁₆ 2000	3/4-10 UNC	5.250	9 2000	1 ¹ / ₈ -8 UN	8.250
2 ⁹ / ₁₆ 3000	1-8 UNC	6.750	9 3000	1 ³ / ₈ -8 UN	9.250
2 ⁹ / ₁₆ 5000	1-8 UNC	6.750	9 5000	1 ⁵ / ₈ -8 UN	12.250
3 ¹ / ₈ 2000	3/4-10 UNC	5.500	11 2000	1 ¹ / ₄ -8 UN	9.000
3 ¹ / ₈ 3000	7/8-9 UNC	6.250	11 3000	1 ³ / ₈ -8 UN	9.750
3 ¹ / ₈ 5000	1 ¹ / ₈ -8 UN	7.500	11 5000	1 ⁷ / ₈ -8 UN	14.000
4 ¹ / ₁₆ 2000	7/8-9 UNC	6.250	13 ⁵ / ₈ 2000	1 ¹ / ₄ -8 UN	9.250
4 ¹ / ₁₆ 3000	1 ¹ / ₈ -8 UN	7.250	13 ⁵ / ₈ 3000	1 ³ / ₈ -8 UN	10.500
4 ¹ / ₁₆ 5000	1 ¹ / ₄ -8 UN	8.250	16 ³ / ₄ 2000	1 ¹ / ₂ -8 UN	10.500
5 ¹ / ₈ 2000	1-8 UNC	7.000	16 ³ / ₄ 3000	1 ⁵ / ₈ -8 UN	12.000
5 ¹ / ₈ 3000	1 ¹ / ₄ -8 UN	8.000	21 ¹ / ₄ 2000	1 ⁵ / ₈ -8 UN	11.750
5 ¹ / ₈ 5000	1 ¹ / ₂ -8 UN	10.250	20 ³ / ₄ 3000	2-8 UN	14.500

FOOTNOTES

* Tolerance on bolt length:
 +0.125, -0 in. for lengths up to 12 in.
 +0.250, -0 in. for lengths over 12 in.

Table I.6—Tap End Stud Length Table for 6B Studded Flange Connectors with “R” Gaskets

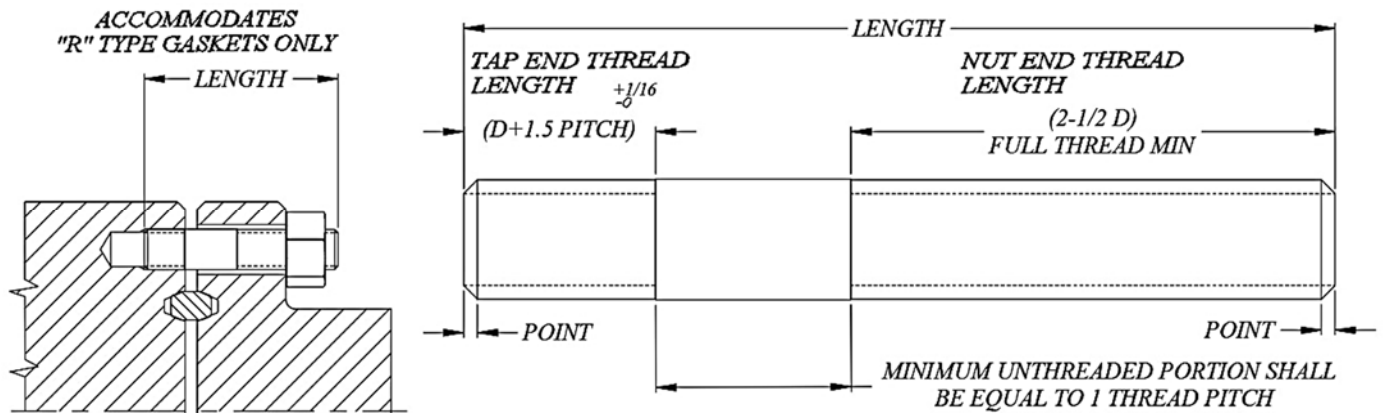

$LENGTH = T + t + d + S + P + TL + RF$

- T* is total flange thickness;
- t* is plus tolerance for flange thickness;
- d* is heavy hex nut thickness;
- S* is flange face standoff (with “R” gasket);
- P* is point, max. (1.5 x pitch);
- TL* is tap end thread length, max. [(one diameter + 1.5 pitch) + $\frac{1}{16}$];
- RF* add amount of raised face present on studded flanges, if not omitted, to the length of studs in table.

Dimensions in inches

Flange Size and Pressure	Bolt Size and Thread	Tap End Length*	Nut End Length	Length**	Flange Size and Pressure	Bolt Size and Thread	Tap End Length*	Nut End Length	Length**
2 ¹ / ₁₆ 2000	5/8-11 UNC	0.761	1.563	3.375	7 ¹ / ₁₆ 2000	1-8 UNC	1.188	2.500	5.000
2 ¹ / ₁₆ 3000	7/8-9 UNC	1.042	2.188	4.375	7 ¹ / ₁₆ 3000	1 ¹ / ₈ -8 UN	1.313	2.813	5.625
2 ¹ / ₁₆ 5000	7/8-9 UNC	1.042	2.188	4.375	7 ¹ / ₁₆ 5000	1 ³ / ₈ -8 UN	1.563	3.438	7.250
2 ⁹ / ₁₆ 2000	3/4-10 UNC	0.900	1.875	3.750	9 2000	1 ¹ / ₈ -8 UN	1.313	2.813	5.625
2 ⁹ / ₁₆ 3000	1-8 UNC	1.188	2.500	4.750	9 3000	1 ³ / ₈ -8 UN	1.563	3.438	6.375
2 ⁹ / ₁₆ 5000	1-8 UNC	1.188	2.500	4.750	9 5000	1 ⁵ / ₈ -8 UN	1.813	4.063	8.125
3 ¹ / ₈ 2000	3/4-10 UNC	0.900	1.875	3.875	11 2000	1 ¹ / ₄ -8 UN	1.438	3.125	6.125
3 ¹ / ₈ 3000	7/8-9 UNC	1.042	2.188	4.375	11 3000	1 ³ / ₈ -8 UN	1.563	3.438	6.625
3 ¹ / ₈ 5000	1 ¹ / ₈ -8 UN	1.313	2.813	5.250	11 5000	1 ⁷ / ₈ -8 UN	2.063	4.688	9.250
4 ¹ / ₁₆ 2000	7/8-9 UNC	1.042	2.188	4.375	13 ⁵ / ₈ 2000	1 ¹ / ₄ -8 UN	1.438	3.125	6.250
4 ¹ / ₁₆ 3000	1 ¹ / ₈ -8 UN	1.313	2.813	5.125	13 ⁵ / ₈ 3000	1 ³ / ₈ -8 UN	1.563	3.438	7.000
4 ¹ / ₁₆ 5000	1 ¹ / ₄ -8 UN	1.438	3.125	5.750	16 ³ / ₄ 2000	1 ¹ / ₂ -8 UN	1.688	3.750	7.125
5 ¹ / ₈ 2000	1-8 UNC	1.188	2.500	4.875	16 ³ / ₄ 3000	1 ⁵ / ₈ -8 UN	1.813	4.063	8.000
5 ¹ / ₈ 3000	1 ¹ / ₄ -8 UN	1.438	3.125	5.625	21 ¹ / ₄ 2000	1 ⁵ / ₈ -8 UN	1.813	4.063	8.000
5 ¹ / ₈ 5000	1 ¹ / ₂ -8 UN	1.688	3.750	7.000	20 ³ / ₄ 3000	2-8 UN	2.188	5.000	9.625

FOOTNOTES

* Tolerance on tap end thread length: +0.063/-0 in.

** Tolerance on tap end stud length; +0.125/-0 in.

Annex J (normative)

Weld-neck Flanges

J.1 General

J.1.1 Application

There shall be two applications of weld-neck flanges as follows.

- Standard: Weld-neck flanges designed and manufactured to be welded to equipment covered by this specification, with or without additional machining, to meet the requirements of 14.1 for integral flanges when completed.
- Nonstandard: Weld-neck flanges designed and manufactured to be welded to piping or other types of equipment not covered by this specification.

J.1.2 Type and Pressure Rating

There shall be two types of weld-neck flanges.

- Type 6B weld-neck flanges shall be designed and manufactured such that they can be bolted to a matching 6B flanged or studded connector with a rated working pressure of 13.8 MPa, 20.7 MPa, or 34.5 MPa (2000 psi, 3000 psi, or 5000 psi).
- Type 6BX weld-neck flanges shall be designed and manufactured such that they can be bolted to a matching 6BX flanged or studded connector with a rated working pressure of 69.0 MPa, 103.5 MPa, or 138.0 MPa (10,000 psi, 15,000 psi, or 20,000 psi).

J.2 Design

J.2.1 Design Responsibility

NOTE A loose weld-neck flange has two distinct sections as shown in Figure J.1, a flange (rim) section and a hub (neck) section.

The following shall apply.

- Design of the flange section in the finished state as an integral flange shall be fully established by the requirements in part 14.1.
- Design of the hub section shall be the responsibility of the manufacturer.

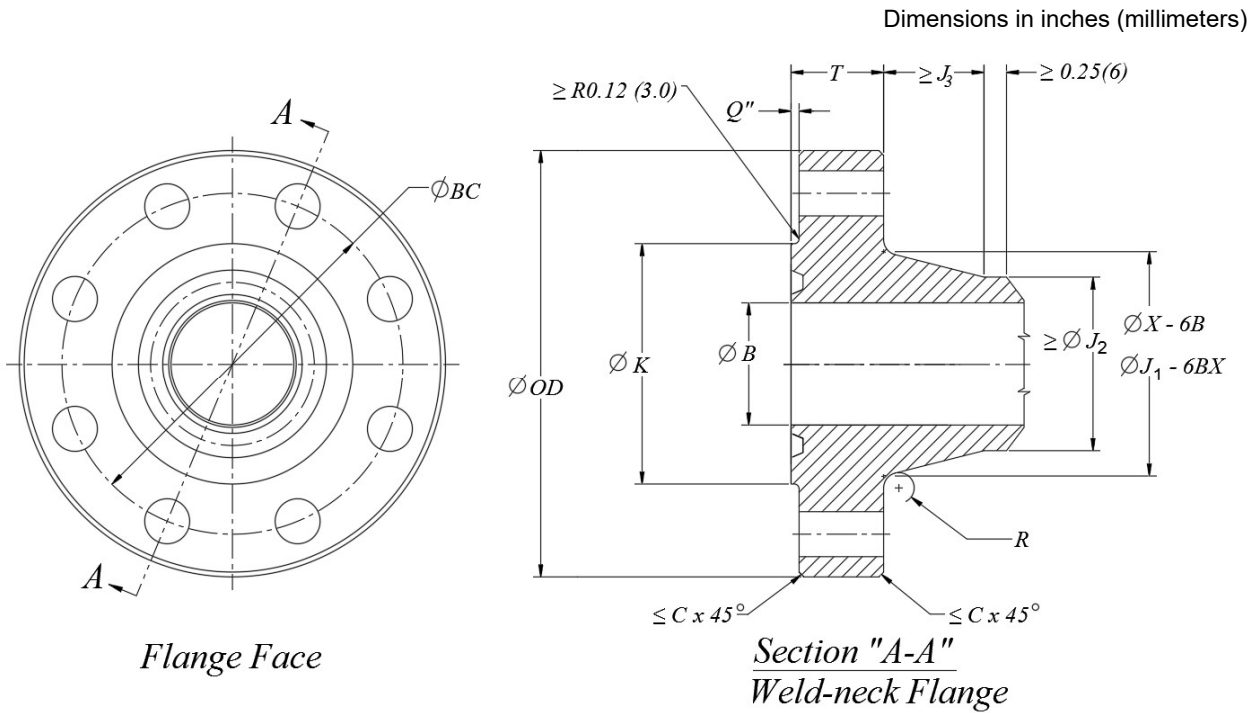

Figure J.1—Weld-neck Flange Dimensions

J.2.2 Flange Dimensions

Dimensions of the weld-neck flange section shall conform to Table D.1/Table E.1, Table D.2/Table E.2, Table D.3/Table E.3, Table D.4/Table E.4, Table D.5/Table E.5, Table D.6/Table E.6 or Table D.7/Table E.7 for the following from Figure J.1:

- B* is maximum bore diameter;
- OD* is outside diameter of flange;
- C* is chamfers (2) on flange OD;
- K* is raised face diameter (if applicable);
- T* is total thickness of flange;
- BC* is bolt circle diameter;
- N* is number of bolt holes;
- BH* is diameter of bolt holes;
- Q* is height of raised face (if applicable).

J.2.3 Hub Dimensions

J.2.3.1 Hub Dimensions for Standard Applications

For weld-neck flanges that are welded to a body or a piece of equipment and subsequently completed as integral flanges, dimensions of the hub section should conform to Table D.1/Table E.1, Table D.2/Table E.2,

Table D.3/Table E.3, Table D.4/Table E.4, Table D.5/Table E.5, Table D.6/Table E.6 or Table D.7/Table E.7 for the following from Figure J.1:

X is hub diameter (at flange), 6B flanges;

J_1 is hub diameter (at flange), 6BX flanges;

J_2 is reduced (optional) hub diameter for 6BX flanges;

J_3 is minimum length of optional taper from J_1 to J_2 for 6BX flanges;

R is fillet radius (between hub section and flange section).

NOTE The taper dimensions J_2 and J_3 are minimum values; a more gradual taper or a straight hub diameter of J_1 is permitted.

For Type 6BX flanges, hub dimensions beyond the J_3 length shall be established by the manufacturer in conformance with Section 5.

For Type 6B flanges, hub dimensions beyond the radius, R , at diameter X shall be established by the manufacturer in conformance with Section 5.

Hub dimensions on equipment for which reduced bores are permitted (for example, chokes, check valves) shall be established by the manufacturer in conformance with Section 5.

J.2.3.12 Hub Dimensions for Nonstandard Applications

For weld-neck flanges designed to be welded to piping or other types of equipment outside the scope of this specification, hub dimensions shall be established by the manufacturer in conformance with Section 5 or other design standard that is applicable to the equipment.

If the nominal bore of the welding end is smaller than the nominal bore of the pipe by a difference of 4.8 mm (0.18 in.) or more, the flange shall be taper bored from the weld end at a slope not exceeding 3 to 1. However, requirements for minimum wall thickness shall apply.

J.2.4 Weld End Preparation

The weld end preparation shall be designed to achieve full penetration of the pressure wall after all machining.

NOTE A recommended preparation design is shown in Figure J.2.

Other preparations shall be acceptable.

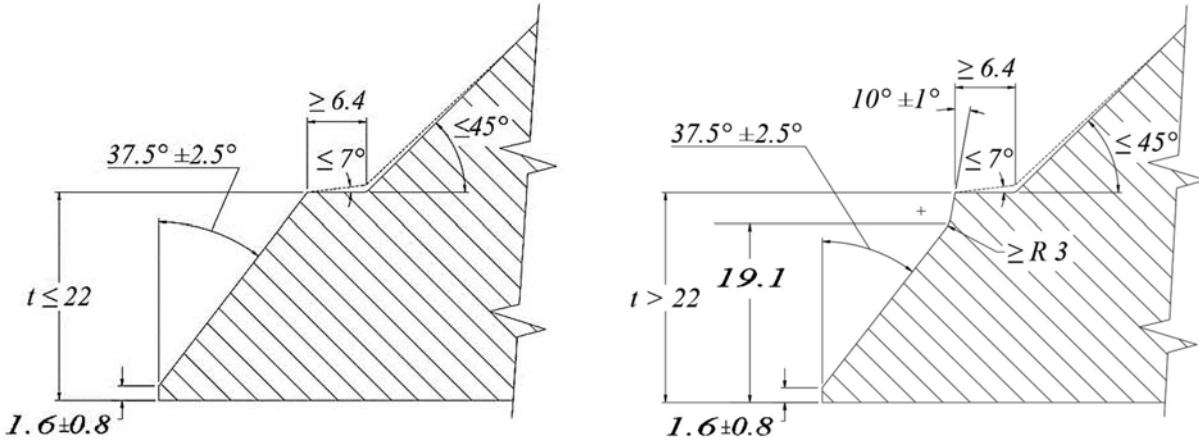

a) Dimensions in millimeters

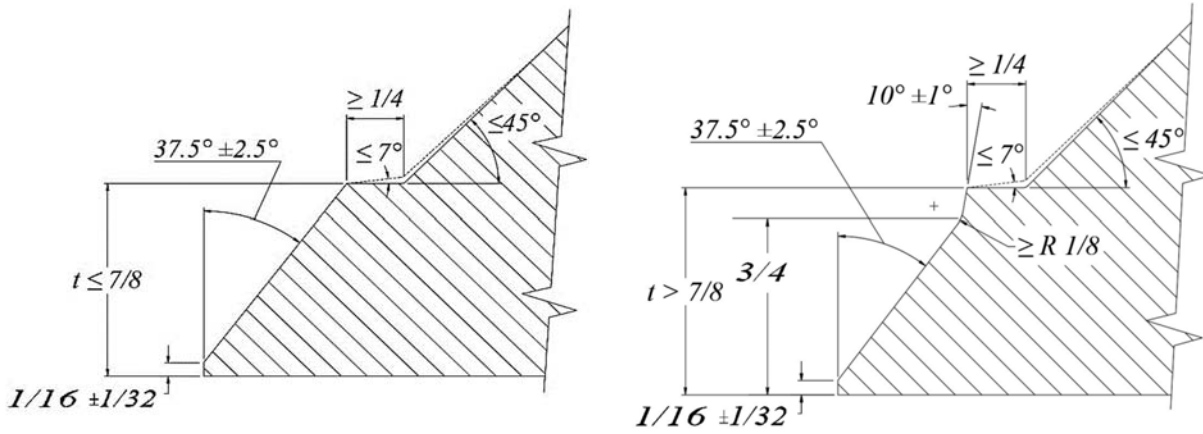

b) Dimensions in inches

Figure J.2—Recommended Weld End Preparation for Type 6B and 6BX Weld-end Flanges

Annex K (informative)

Top Connectors

K.1 General

Annex K recommends dimensions and material strengths for top connectors, also known as tree caps, for the most common sizes and pressure ratings. The dimensions and material specifications indicated allow for conformance with all other requirements for top connectors, as specified in this specification.

If this annex is applied, the following requirements shall be met.

K.2 Materials

Materials shall meet the requirements of 6.2 and have a minimum 0.2 % offset yield strength of 517 MPa (75,000 psi) and a maximum hardness of 237 HBW to be suitable for H₂S service. The appropriate material selection shall be made in accordance with Table 3.

K.3 Design

NOTE 1 The top connectors are designed for use in combinations of nominal size ranges and rated working pressure as shown in Table K.1 and Table K.2 and Figure K.1 and Figure K.2.

NOTE 2 Provisions on the bonnet nut other than those indicated in Figure K.1 and Figure K.2 for transfer of make-up torque may be provided but are not specified in this specification.

The threads shall conform to ASME B1.5 Acme screw threads, as specified in Table K.1.

K.4 Dimensions—Top Connector, Seal, Bleeder Connector

Dimensions for top connectors shall conform to Table K.1, Table K.2, Table K.3 and Table K.4; flanges shall conform to the appropriate tables and requirements of 14.1, and 16B and 16BX clamp hubs shall conform to API 16A.

The dimensions and materials of the “O”-ring seals of the caps are specified in Table K.5, Table K.6, and Table K.7 and shall conform to SAE AS568A.

The dimensions of the bleeder connector shall conform to 9.3 depending on the pressure rating of the top connector.

K.5 Quality Control

The quality control requirements shall be in accordance with 14.7.4.

K.6 Marking

Marking shall be as specified in Section 12.

K.7 Storing and Shipping

Storing and shipping shall be as specified in Section 13.

Table K.1—Standard Top Connector Sizes

Nominal Tree Cap Bore Size in.	Rated Working Pressure		Thread Size A ^a in.	Seal Bore Diameter	
	MPa	psi		mm	in.
2 ⁹ / ₁₆	103.5	15,000 ^b	5 ³ / ₄ — 4THD Acme-2G	101.60	4.000
2 ⁹ / ₁₆	138.0	20,000	6 ¹ / ₄ — 4THD Acme-2G	101.60	4.000
3 ¹ / ₈	34.5	5000 ^b	5 ³ / ₄ — 4THD Acme-2G	101.60	4.000
3 ¹ / ₁₆	69.0	10,000	5 ³ / ₄ — 4THD Acme-2G	101.60	4.000
3 ¹ / ₁₆	103.5	15,000	7 ¹ / ₂ — 4THD Acme-2G	139.70	5.500
4 ¹ / ₁₆	34.5	5000 ^b	8 ³ / ₈ — 4THD Acme-2G	133.35	5.250
4 ¹ / ₁₆	69.0	10,000	8 ³ / ₈ — 4THD Acme-2G	133.35	5.250
4 ¹ / ₁₆	103.5	15,000	9 ¹ / ₂ — 4THD Acme-2G	158.75	6.250
5 ¹ / ₈	34.5	5000 ^b	9 — 4THD Acme-2G	171.45	6.750
5 ¹ / ₈	69.0	10,000	9 — 4THD Acme-2G	171.45	6.750
5 ¹ / ₈	103.5	15,000	12 ¹ / ₄ — 4THD Acme-2G	177.80	7.000
6 ³ / ₈	34.5	5000 ^b	9 ¹ / ₂ — 4THD Acme-2G	203.20	8.000
6 ³ / ₈	69.0	10,000	11 ¹ / ₂ — 4THD Acme-2G	209.55	8.250

FOOTNOTES
^a See Figure K.1 and Figure K.2.
^b Pressures up to and including this rated working pressure.

Table K.2—Top Connector Body, Inside and Outside Diameter Combinations

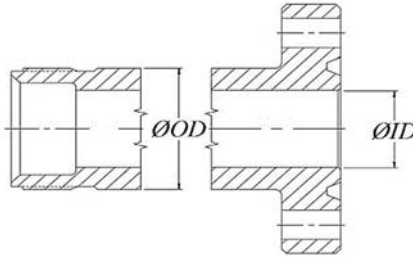

Nominal Size in.	Rated Working Pressure		ID Maximum Inside Diameter ^a		OD Minimum Outside Diameter	
	MPa	psi	mm	in.	mm	in.
2 ⁹ / ₁₆	103.5	15,000	65.8	2.59	109.0	4.29
2 ⁹ / ₁₆	138.0	20,000	65.8	2.59	144.5	5.69
3 ¹ / ₈	34.5	5000	81.8	3.22	94.5	3.72
3 ¹ / ₁₆	69.0	10,000	78.5	3.09	104.6	4.12
3 ¹ / ₁₆	103.5	15,000	78.5	3.09	126.7	4.99
4 ¹ / ₁₆	34.5	5000	108.7	4.28	125.7	4.95
4 ¹ / ₁₆	69.0	10,000	103.9	4.09	139.2	5.48
4 ¹ / ₁₆	103.5	15,000	103.9	4.09	166.4	6.55
5 ¹ / ₈	34.5	5000	131.1	5.16	157.0	6.18
5 ¹ / ₈	69.0	10,000	131.1	5.16	174.0	6.85
5 ¹ / ₈	103.5	15,000	131.1	5.16	212.1	8.35
6 ³ / ₈	34.5	5000	162.8	6.41	200.2	7.88
6 ³ / ₈	69.0	10,000	162.8	6.41	221.7	8.73

FOOTNOTE
^a See Figure K.1 and Figure K.2.

Dimensions in millimeters unless noted otherwise;
surface roughness in micrometers

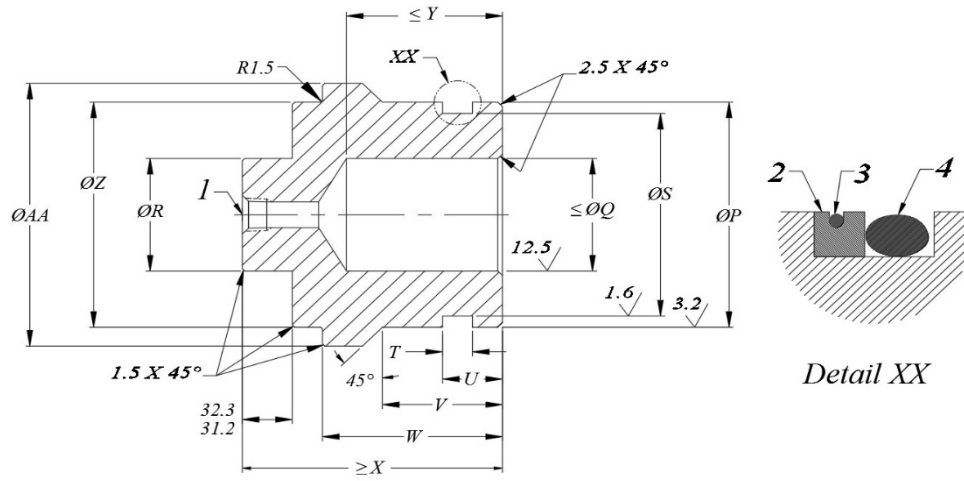

a) Blanking plug

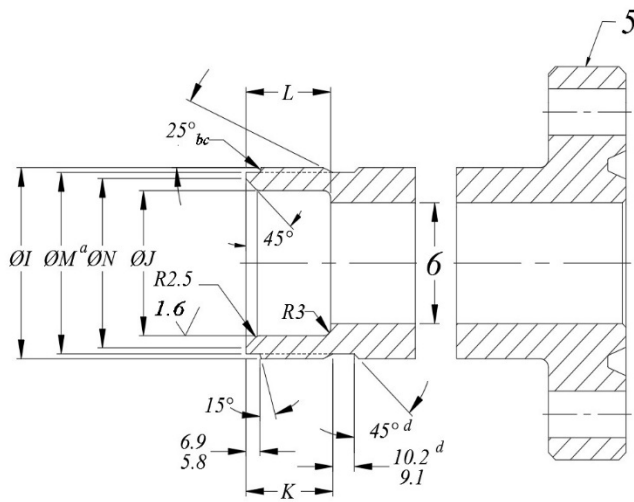

b) Body

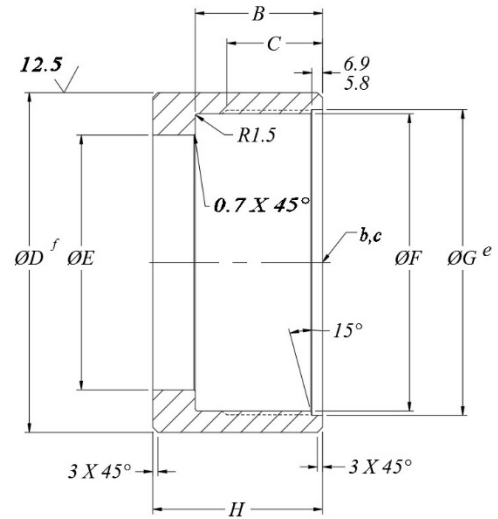

c) Bonnet nut

Key

- 1 bleed port connector
- 2 back-up ring (if used)
- 3 O-ring (if back-up ring is used)
- 4 seal
- 5 flange in accordance with 14.1
- 6 ID in accordance with Table K.2
- a Use $1.5 \times 45^\circ$ for radial wall thickness less than 10.16 mm.
- b A-4 thread 29° Acme 2G.
- c Remove feather edge (see Table K.1).
- d If applicable.
- e Thread relief.
- f Gripping grooves 1.5 ± 0.5 wide x 1.0 ± 0.5 deep x 45° walls. Typically, there are 36 grooves along entire length equally spaced around OD. Visually inspect grooves only.

Figure K.1—Top Connector for Tree—SI Units

Table K.3—Dimensions for Top Connectors—SI Units
(See Figure K.1 for Location of Dimensions)

Dimensions in millimeters

Dimensions	Nominal Size							
	2 ⁹ / ₁₆	3 ¹ / ₈	3 ¹ / ₁₆	2 ⁹ / ₁₆	3 ¹ / ₁₆	4 ¹ / ₁₆	4 ¹ / ₁₆	
	Rated Working Pressure MPa							
	103.5	34.5	69.0	138.0	103.5	34.5	69.0	
<i>B</i>	113.3/114.3		114.3/115.3		113.8/114.3		118.6/119.1	
<i>C</i>	88.9/91.9		91.9/92.5		88.9/89.4		92.2/92.7	
<i>D</i>	166.1/165.1		191.5/190.5		216.9/215.9		242.6/242.1	
<i>E</i>	115.6/116.1		134.6/135.1		155.2/155.7		182.1/182.6	
<i>F</i>	139.70/140.00		152.40/152.70		184.15/184.45		206.38/206.68	
<i>G</i>	147.57/148.08		160.27/160.78		192.02/192.53		214.25/214.76	
<i>H</i>	140.7/139.7		140.7/139.7		140.7/139.7		140.0/138.9	
<i>I</i>	146.05/145.72		158.75/158.42		190.50/190.17		212.73/212.39	
<i>J</i>	101.60/101.75		101.60/101.75		139.70/139.85		133.35/133.50	
<i>K</i>	86.9/85.9		82.8/81.8		91.4/90.4		95.8/94.7	
<i>L</i>	75.7/76.7		91.4/92.5		75.7/76.7		67.6/68.6	
<i>M</i>	137.52/137.01		150.16/149.68		181.81/181.31		203.96/203.45	
<i>N</i>	126.5/127.5		145.5/146.6		164.6/165.6		188.5/189.5	
<i>P</i>	101.50/101.35		101.50/101.35		139.60/139.45		133.25/133.10	
<i>Q</i>	66.5		66.5		91.7		102.1	
<i>R</i>	51.3/50.3		51.3/50.3		51.3/50.3		51.3/50.3	
<i>S</i>	92.35/92.20		92.35/92.20		130.45/130.30		121.46/121.31	
<i>T</i>	6.6/7.6		17.0/18.0		17.5/18.5		9.1/10.2	
<i>U</i>	18.5/19.6		34.5/35.6		34.5/35.6		18.5/19.6	
<i>V</i>	60.5/61.5		60.5/61.5		60.5/61.5		36.1/37.1	
<i>W</i>	106.2/105.2		114.8/113.8		106.2/105.2		97.0/96.0	
<i>X</i>	166.9		174.5		165.4		148.3	
<i>Y</i>	76.2		88.9		76.2		70.4	
<i>Z</i>	114.8/114.3		133.9/133.4		154.4/153.9		178.3/177.8	
<i>AA</i>	139.4/138.9		151.9/151.4		181.9/181.4		204.7/204.2	

Dimensions in millimeters unless noted otherwise;
surface roughness in micrometers

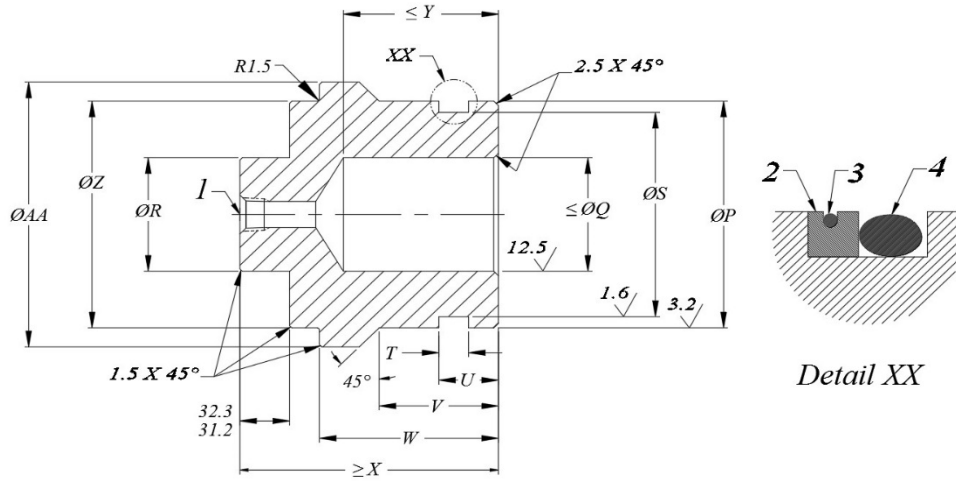

a) Blanking plug

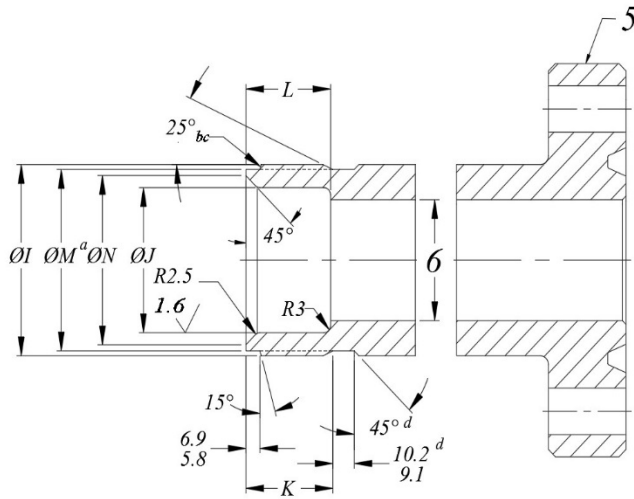

b) Body

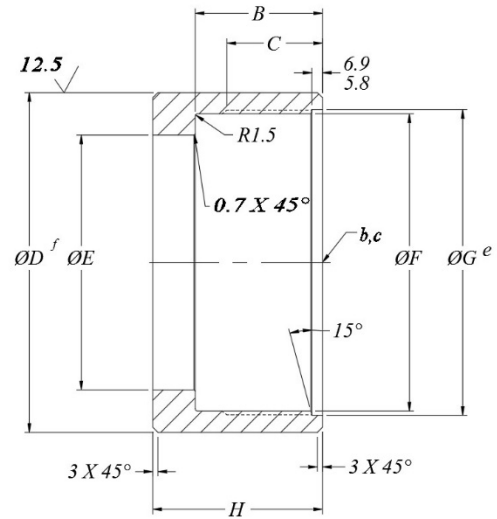

c) Bonnet nut

Key

- 1 bleed port connector
- 2 back-up ring (if used)
- 3 O-ring (if back-up ring is used)
- 4 seal
- 5 flange in accordance with 14.1
- 6 ID in accordance with Table K.2
- a Use 1.5 x 45° for radial wall thickness less than 10.16 mm.
- b A-4 thread 29° Acme 2G.
- c Remove feather edge (see Table K.1).
- d If applicable.
- e Thread relief.
- f Gripping grooves 1.5 ± 0.5 wide x 1.0 ± 0.5 deep x 45° walls. Typically, there are 36 grooves along entire length equally spaced around OD. Visually inspect grooves only.

Figure K.1—Top Connector for Tree—SI Units (repeated)

Table K.3—Dimensions for Top Connectors—SI Units (continued)
 (See Figure K.1 for Location of Dimensions)

Dimensions in millimeters

Dimensions	Nominal Size					
	4 ¹ / ₁₆	5 ¹ / ₈	5 ¹ / ₈	5 ¹ / ₈	6 ³ / ₈	6 ³ / ₈
	Rated Working Pressure MPa					
	103.5	34.5	69.0	103.5	34.5	69.0
<i>B</i>	116.8/117.3	113.8/114.3		177.8/178.3	113.8/114.3	153.4/153.9
<i>C</i>	101.6/102.1	101.6/102.1		136.7/137.2	101.6/102.1	123.7/125.2
<i>D</i>	277.9/276.9	267.7/266.7		369.3/368.3	267.7/266.7	331.2/330.2
<i>E</i>	209.6/210.1	200.9/201.4		261.4/261.9	217.2/217.7	253.2/253.7
<i>F</i>	234.95/235.25	222.25/222.55		304.80/305.10	234.95/235.25	285.75/286.05
<i>G</i>	242.82/243.33	230.12/230.63		312.67/313.18	242.82/243.33	293.62/294.13
<i>H</i>	140.7/139.7	140.7/139.7		222.8/221.7	140.7/139.7	186.2/185.2
<i>I</i>	241.30/240.97	228.60/228.27		311.15/310.82	241.30/240.97	292.10/291.77
<i>J</i>	158.75/158.90	171.45/171.60		177.80/177.95	203.20/203.35	209.55/209.70
<i>K</i>	82.3/81.3	100.6/99.6		118.6/117.6	102.1/101.1	117.9/116.8
<i>L</i>	88.9/89.9	72.6/73.7		111.3/112.3	68.6/69.6	94.7/95.8
<i>M</i>	234.44/233.93	219.81/219.30		302.11/301.60	232.46/231.95	283.11/282.60
<i>N</i>	218.2/219.2	202.7/203.7		289.1/290.1	228.1/229.1	272.5/273.6
<i>P</i>	158.65/158.50	171.35/171.20		177.70/177.55	203.10/202.95	209.45/209.30
<i>Q</i>	102.1	140.7		130.0	177.8	162.6
<i>R</i>	51.3/50.3	51.3/50.3		51.3/50.3	51.3/50.3	51.3/50.3
<i>S</i>	146.86/146.71	159.56/159.41		165.91/165.76	191.31/191.16	197.66/197.51
<i>T</i>	17.0/18.0	9.1/10.2		19.8/20.8	9.1/10.2	19.8/20.8
<i>U</i>	31.2/32.3	23.1/24.1		40.6/41.7	20.3/21.3	40.6/41.7
<i>V</i>	52.8/53.8	53.3/54.4		51.3/52.3	53.3/54.4	51.3/52.3
<i>W</i>	118.9/117.9	102.1/101.1		159.3/158.2	91.4/90.4	124.5/123.4
<i>X</i>	172.0	157.7		236.0	150.6	189.5
<i>Y</i>	83.8	95.0		114.3	53.3	96.5
<i>Z</i>	206.8/206.2	200.2/199.6		260.6/260.1	216.4/215.9	252.5/252.0
<i>AA</i>	233.4/232.9	220.7/220.2		303.5/303.0	233.9/233.4	284.2/283.7

Dimensions in inches unless noted otherwise;
surface roughness in microinches

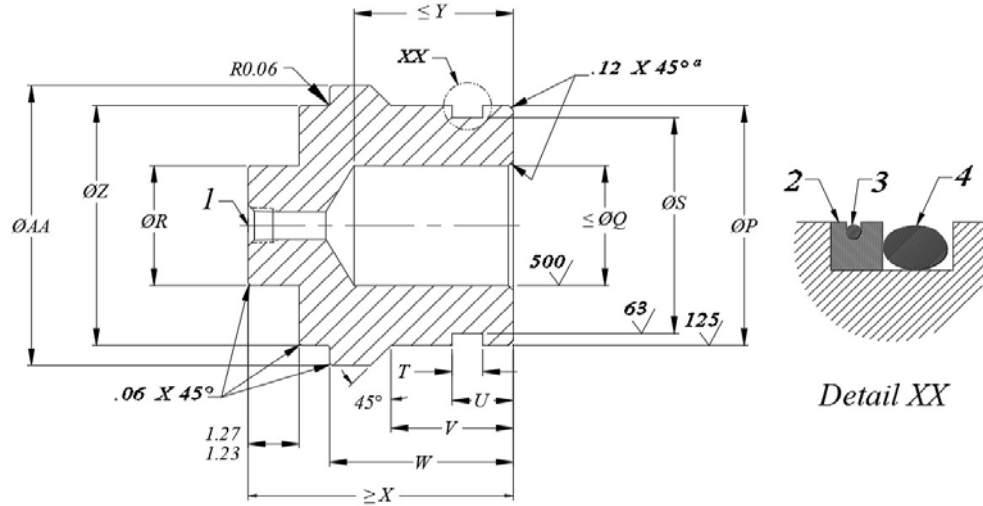

a) Blanking plug

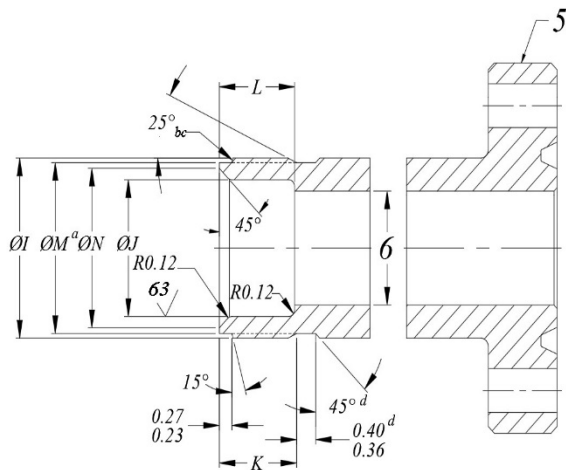

b) Body

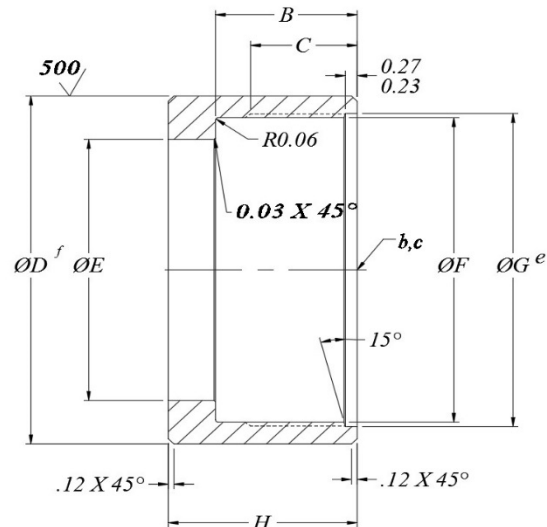

c) Bonnet nut

Key

- 1 bleed port connector
 - 2 back-up ring (if used)
 - 3 O-ring (if back-up ring is used)
 - 4 seal
 - 5 flange in accordance with 14.1
 - 6 ID in accordance with Table K.2
- a Use 0.06 x 45° for radial wall thickness less than 0.40 in.
 - b A-4 THD 29° Acme 2G.
 - c Remove feather edge (see Table K.1).
 - d If applicable.
 - e Thread relief.
 - f Gripping grooves 0.06 ± 0.02 wide x 0.04 ± 0.02 deep x 45° walls. Typically, there are 36 grooves along entire length equally spaced around OD. Visually inspect grooves only.

Figure K.2—Top Connector for Tree—USC Units

Table K.4—Dimensions for Top Connectors—USC Units
(See Figure K.2 for Location of Dimensions)

Dimensions in inches

Dimensions	Nominal Size								
	2 ⁹ / ₁₆	3 ¹ / ₈	3 ¹ / ₁₆	2 ⁹ / ₁₆	3 ¹ / ₁₆	4 ¹ / ₁₆	4 ¹ / ₁₆		
	Rated Working Pressure psi								
	15,000	5000	10,000	20,000	15,000	5000	10,000		
<i>B</i>	4.46/4.50			4.50/4.54		4.48/4.50		4.67/4.69	
<i>C</i>	3.50/3.62			3.62/3.64		3.50/3.52		3.63/3.65	
<i>D</i>	6.54/6.50			7.54/7.50		8.54/8.50		9.55/9.53	
<i>E</i>	4.55/4.57			5.30/5.32		6.11/6.13		7.17/7.19	
<i>F</i>	5.500/5.512			6.000/6.012		7.250/7.262		8.125/8.137	
<i>G</i>	5.810/5.830			6.310/6.330		7.560/7.580		8.435/8.455	
<i>H</i>	5.54/5.50			5.54/5.50		5.54/5.50		5.51/5.47	
<i>I</i>	5.750/5.737			6.250/6.237		7.500/7.487		8.375/8.362	
<i>J</i>	4.000/4.006			4.000/4.006		5.500/5.506		5.250/5.256	
<i>K</i>	3.42/3.38			3.26/3.22		3.60/3.56		3.77/3.73	
<i>L</i>	2.98/3.02			3.60/3.64		2.98/3.02		2.66/2.70	
<i>M</i>	5.414/5.394			5.912/5.893		7.158/7.138		8.030/8.010	
<i>N</i>	4.98/5.02			5.73/5.77		6.48/6.52		7.42/7.46	
<i>P</i>	3.996/3.990			3.996/3.990		5.496/5.490		5.246/5.240	
<i>Q</i>	2.62			2.62		3.61		4.02	
<i>R</i>	2.02/1.98			2.02/1.98		2.02/1.98		2.02/1.98	
<i>S</i>	3.636/3.630			3.636/3.630		5.136/5.130		4.782/4.776	
<i>T</i>	0.26/0.30			0.67/0.71		0.69/0.73		0.36/0.40	
<i>U</i>	0.73/0.77			1.36/1.40		1.36/1.40		0.73/0.77	
<i>V</i>	2.38/2.42			2.38/2.42		2.38/2.42		1.42/1.46	
<i>W</i>	4.18/4.14			4.52/4.48		4.18/4.14		3.82/3.78	
<i>X</i>	6.57			6.87		6.51		5.84	
<i>Y</i>	3.00			3.50		3.00		2.77	
<i>Z</i>	4.52/4.50			5.27/5.25		6.08/6.06		7.02/7.00	
<i>AA</i>	5.49/5.47			5.98/5.96		7.16/7.14		8.06/8.04	

Dimensions in inches unless noted otherwise;
surface roughness in microinches

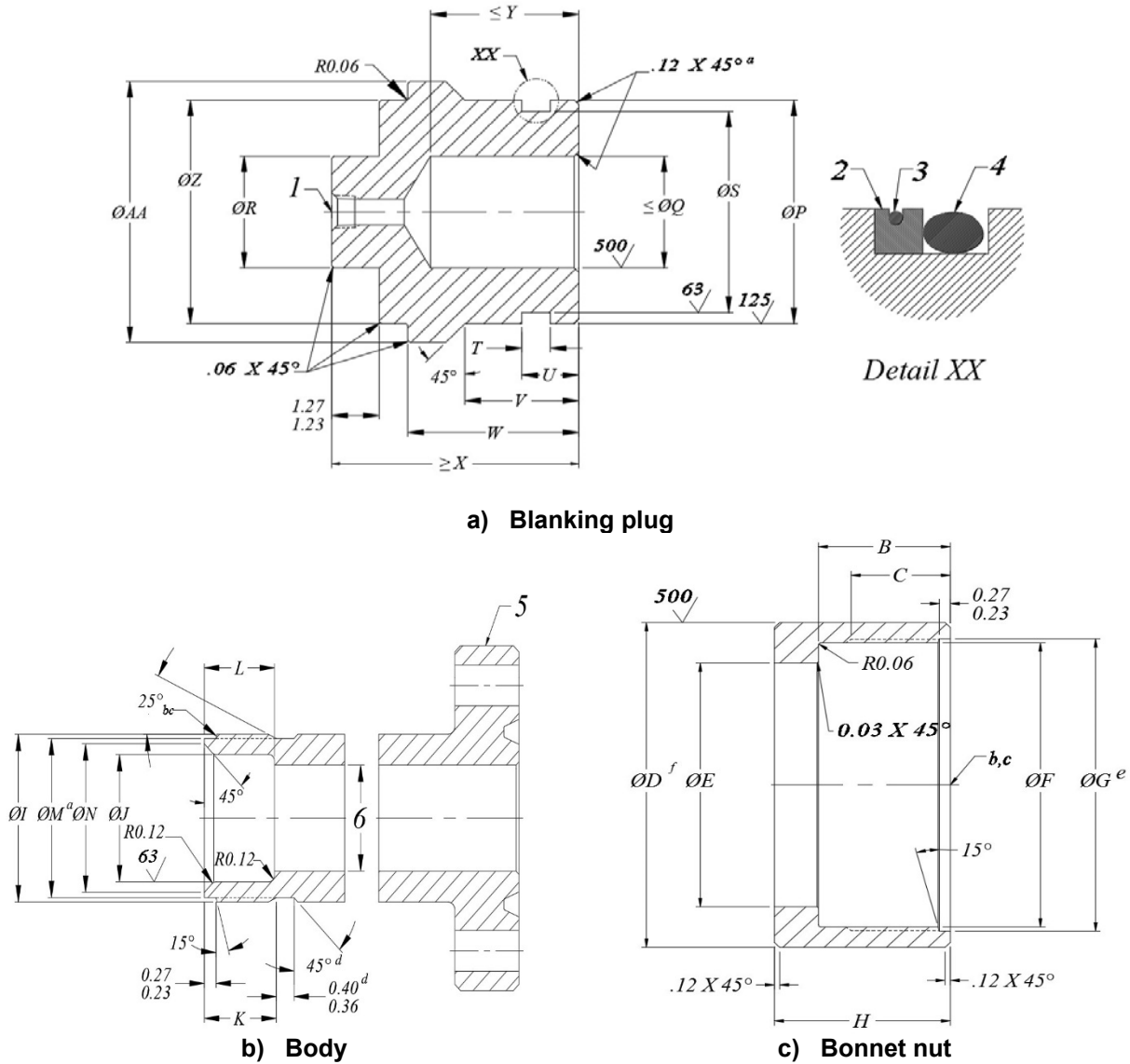

Key

- 1 bleed port connector
 - 2 back-up ring (if used)
 - 3 O-ring (if back-up ring is used)
 - 4 seal
 - 5 flange in accordance with 14.1
 - 6 ID in accordance with Table K.2
- a Use 0.06 x 45° for radial wall thickness less than 0.40 in.
 - b A-4 THD 29° Acme 2G.
 - c Remove feather edge (see Table K.1).
 - d If applicable.
 - e Thread relief.
 - f Gripping grooves 0.06 ± 0.02 wide x 0.04 ± 0.02 deep x 45° walls. Typically, there are 36 grooves along entire length equally spaced around OD. Visually inspect grooves only.

Figure K.2—Top Connector for Tree—USC Units (repeated)

Table K.4—Dimensions for Top Connectors—USC Units (*continued*)
 (See Figure K.2 for Location of Dimensions)

Dimensions in inches

Dimensions	Nominal Size					
	4 ¹ / ₁₆	5 ¹ / ₈	5 ¹ / ₈	5 ¹ / ₈	6 ³ / ₈	6 ³ / ₈
	Rated Working Pressure psi					
	15,000	5000	10,000	15,000	5000	10,000
<i>B</i>	4.60/4.62	4.48/4.50		7.00/7.02	4.48/4.50	6.04/6.06
<i>C</i>	4.00/4.02	4.00/4.02		5.38/5.40	4.00/4.02	4.87/4.93
<i>D</i>	10.94/10.90	10.54/10.50		14.54/14.50	10.54/10.50	13.04/13.00
<i>E</i>	8.25/8.27	7.91/7.93		10.29/10.31	8.55/8.57	9.97/9.99
<i>F</i>	9.250/9.262	8.750/8.762		12.000/12.012	9.250/9.262	11.250/11.262
<i>G</i>	9.560/9.580	9.060/9.080		12.310/12.330	9.56/9.58	11.56/11.58
<i>H</i>	5.54/5.50	5.54/5.50		8.77/8.73	5.54/5.50	7.33/7.29
<i>I</i>	9.500/9.487	9.000/8.987		12.250/12.237	9.500/9.487	11.500/11.487
<i>J</i>	6.250/6.256	6.750/6.756		7.000/7.006	8.000/8.006	8.250/8.256
<i>K</i>	3.24/3.20	3.96/3.92		4.67/4.63	4.02/3.98	4.64/4.60
<i>L</i>	3.50/3.54	2.86/2.90		4.38/4.42	2.70/2.74	3.73/3.77
<i>M</i>	9.230/9.210	8.654/8.634		11.894/11.874	9.152/9.132	11.146/11.126
<i>N</i>	8.59/8.63	7.98/8.02		11.38/11.42	8.98/9.02	10.73/10.77
<i>P</i>	6.246/6.240	6.746/6.740		6.996/6.990	7.996/7.990	8.246/8.240
<i>Q</i>	4.02	5.54		5.12	7.00	6.40
<i>R</i>	2.02/1.98	2.02/1.98		2.02/1.98	2.02/1.98	2.02/1.98
<i>S</i>	5.782/5.776	6.282/6.276		6.532/6.526	7.532/7.526	7.782/7.776
<i>T</i>	0.67/0.71	0.36/0.40		0.78/0.82	0.36/0.40	0.78/0.82
<i>U</i>	1.23/1.27	0.91/0.95		1.60/1.64	0.80/0.84	1.60/1.64
<i>V</i>	2.08/2.12	2.10/2.14		2.02/2.06	2.10/2.14	2.02/2.06
<i>W</i>	4.68/4.64	4.02/3.98		6.27/6.23	3.60/3.56	4.90/4.86
<i>X</i>	6.77	6.21		9.29	5.93	7.46
<i>Y</i>	3.30	3.74		4.50	2.10	3.80
<i>Z</i>	8.14/8.12	7.88/7.86		10.26/10.24	8.52/8.50	9.94/9.92
<i>AA</i>	9.19/9.17	8.69/8.67		11.95/11.93	9.21/9.19	11.19/11.17

Dimensions in millimeters unless noted otherwise

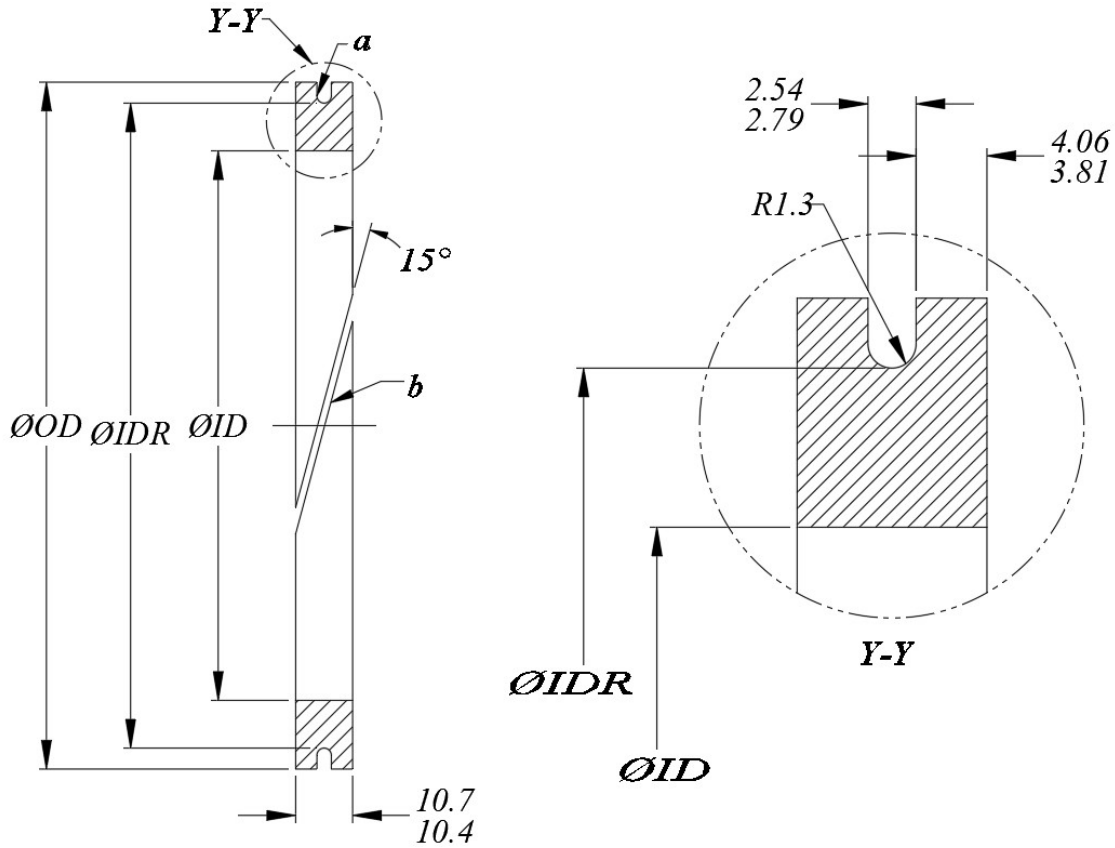

FOOTNOTES

^a For O-ring size, see Table K.5.

^b Make 1 cut as shown 0.8 mm wide flush; steps not allowed.

NOTE Material is nylon. Prior to installation, soften by boiling in water for 4 h.

Figure K.3—Back-up Ring for Seal—SI Units

Table K.5—Seals for Top Connector Plugs for H₂S Service

Nominal Size in.	Rated Working Pressure		Seals ^a	Back-up Ring Required ^b
	MPa	psi		
2 ⁹ / ₁₆	103.5	15,000	SAE AS 568-342-90 FKM	—
3 ¹ / ₈	34.5	5000	SAE AS 568-342-90 FKM	—
3 ¹ / ₁₆	69.0	10,000	SAE AS 568-342-90 FKM	—
2 ⁹ / ₁₆	138.0	20,000	SAE AS 568-342-90 FKM SAE AS 568-153-80 FKM ^c	Yes
3 ¹ / ₁₆	103.5	15,000	SAE AS 568-354-90 FKM SAE AS 568-159-80 FKM ^c	Yes
4 ¹ / ₁₆	34.5	5000	SAE AS 568-427-90 FKM	—
4 ¹ / ₁₆	69.0	10,000	SAE AS 568-427-90 FKM	—
4 ¹ / ₁₆	103.5	15,000	SAE AS 568-435-90 FKM SAE AS 568-161-80 FKM ^c	Yes
5 ¹ / ₈	34.5	5000	SAE AS 568-438-90 FKM	—
5 ¹ / ₈	69.0	10,000	SAE AS 568-438-90 FKM	—
5 ¹ / ₈	103.5	15,000	SAE AS 568-439-90 FKM SAE AS 568-166-80 FKM ^c	Yes
6 ³ / ₈	34.5	5000	SAE AS 568-443-90 FKM	—
6 ³ / ₈	69.0	10,000	SAE AS 568-444-90 FKM SAE AS 568-168-80 FKM ^c	Yes

FOOTNOTES
 All O-rings specified are suitable for H₂S service.
^a FKM according to ASTM D1418.
^b See Figure K.3 and Table K.6 for back-up ring details and dimensions.
^c The O-rings marked 80 (durometer) are used on the outside of a back-up ring.

Table K.6—Back-up Ring for Seal—SI Units
(See Figure K.3 for Location of Dimensions)

Dimensions in millimeters unless noted otherwise

Nominal Size in.	Rated Working Pressure MPa	<i>OD</i>	<i>IDR</i>	<i>ID</i>
2 ⁹ / ₁₆	138.0	102.84/102.95	97.79/98.04	93.65/93.75
3 ¹ / ₁₆	103.5	140.94/141.10	135.64/136.14	131.80/131.95
4 ¹ / ₁₆	103.5	159.94/160.10	154.69/154.94	148.31/148.46
5 ¹ / ₈	103.5	178.59/178.74	172.97/173.23	166.70/166.85
6 ³ / ₈	69.0	210.34/210.49	204.72/204.98	198.45/198.60

Dimensions in inches unless noted otherwise

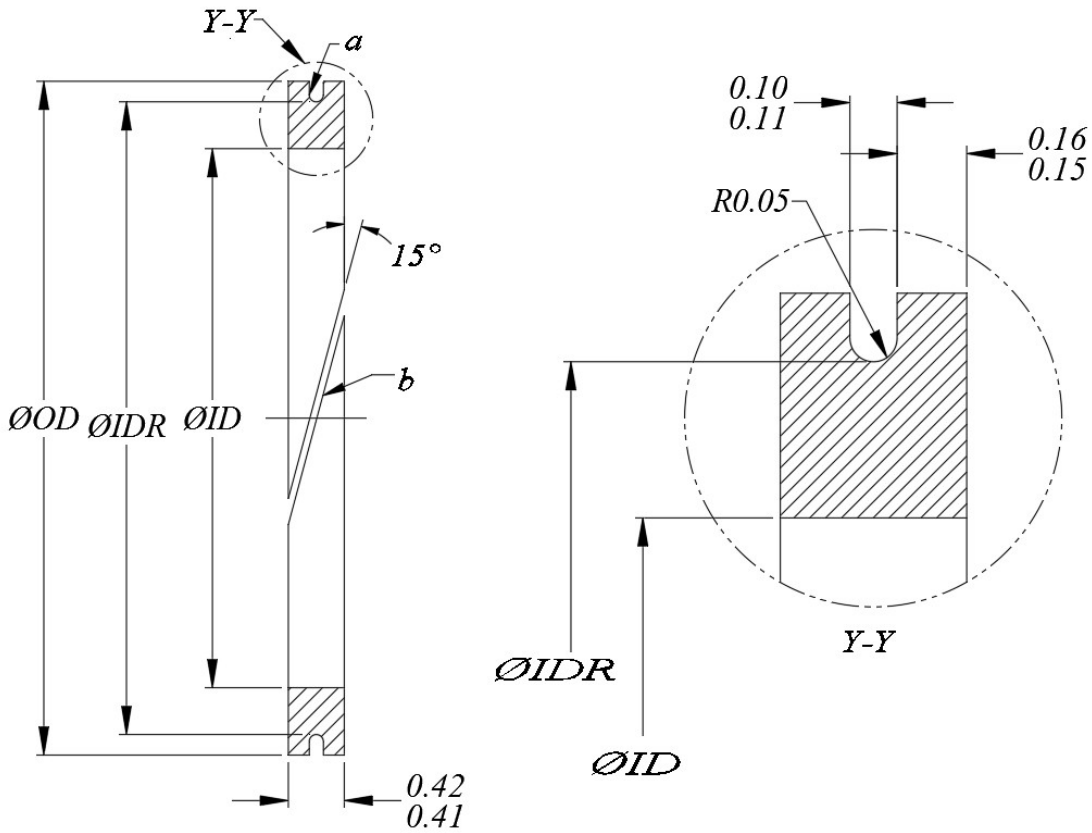

FOOTNOTES

- a For O-ring size, see Table K.5.
- b Make 1 cut as shown 0.03 in. wide flush; steps not allowed.

Material is nylon. Prior to installation, soften by boiling in water for 4 h.

Figure K.4—Back-up Ring for Seal—USC Units

Table K.7—Back-up Ring for Seal—USC Units
(See Figure K.4 for Location of Dimensions)

Dimensions in inches

Nominal Size	Rated Working Pressure			
in.	psi	OD	IDR	ID
2 ⁹ / ₁₆	20,000	4.049/4.053	3.85/3.86	3.687/3.691
3 ¹ / ₁₆	15,000	5.549/5.555	5.34/5.36	5.189/5.195
4 ¹ / ₁₆	15,000	6.297/6.303	6.09/6.10	5.839/5.845
5 ¹ / ₈	15,000	7.031/7.037	6.81/6.82	6.563/6.569
6 ³ / ₈	10,000	8.281/8.287	8.06/8.07	7.813/7.819

Annex L (informative)

Segmented Flanges

L.1 General

NOTE 1 Segmented flanges for dual completion are included in this specification to provide interchangeable replacement equipment for existing installations.

NOTE 2 Segmented flanges are of the ring-joint type and are designed with the ring groove in a recessed counterbore. Depending on tolerances and whether the gasket has been properly seated, the connection make-up bolting force can react on the surface outside the recessed face of the flange.

The segmented flange shall be of the through-bolted or studded design.

NOTE 3 Face-to-face contact is not necessary for the proper functioning of segmented flanges.

L.2 Dimensions

Segmented flange dimensions shall conform to Table L.1. Ring groove dimensions shall conform to Table L.2.

L.3 Flange Face

The flange face shall be fully machined. The nut-bearing surface shall be parallel to the flange gasket counterbored face within 1°. The back face may be fully machined or spot-faced at the bolt holes.

L.4 Gaskets

Segmented flanges shall use RX gaskets specified in Table L.2 that conform to the requirements of 14.2.

L.5 Corrosion-resistant Ring Grooves

Corrosion-resistant ring grooves manufactured in segmented flanges shall meet the specified minimum yield strength of the base material.

L.6 Service Limitations

These flanges shall not be used for H₂S service, and shall not be marked with material classes DD, EE, FF, or HH.

NOTE The use of these flanges for gas service with or without H₂S is not recommended.

L.7 Installation

Segmented flanges should be used in pairs (i.e. two flanges side-by-side, for dual completions). Manifolds should be rigidly clamped together to add stability to the flanges when subjected to bending loads.

L.8 Ring Groove Surface

The 23° surfaces on ring grooves shall have a surface finish no rougher than 1.6 µm *Ra* (63 µin. RMS).

Table L.1—Dimensions for 34.5 MPa Rated Working Pressure, Segmented Flanges for Dual Completion

a) SI units

Dimensions in millimeters

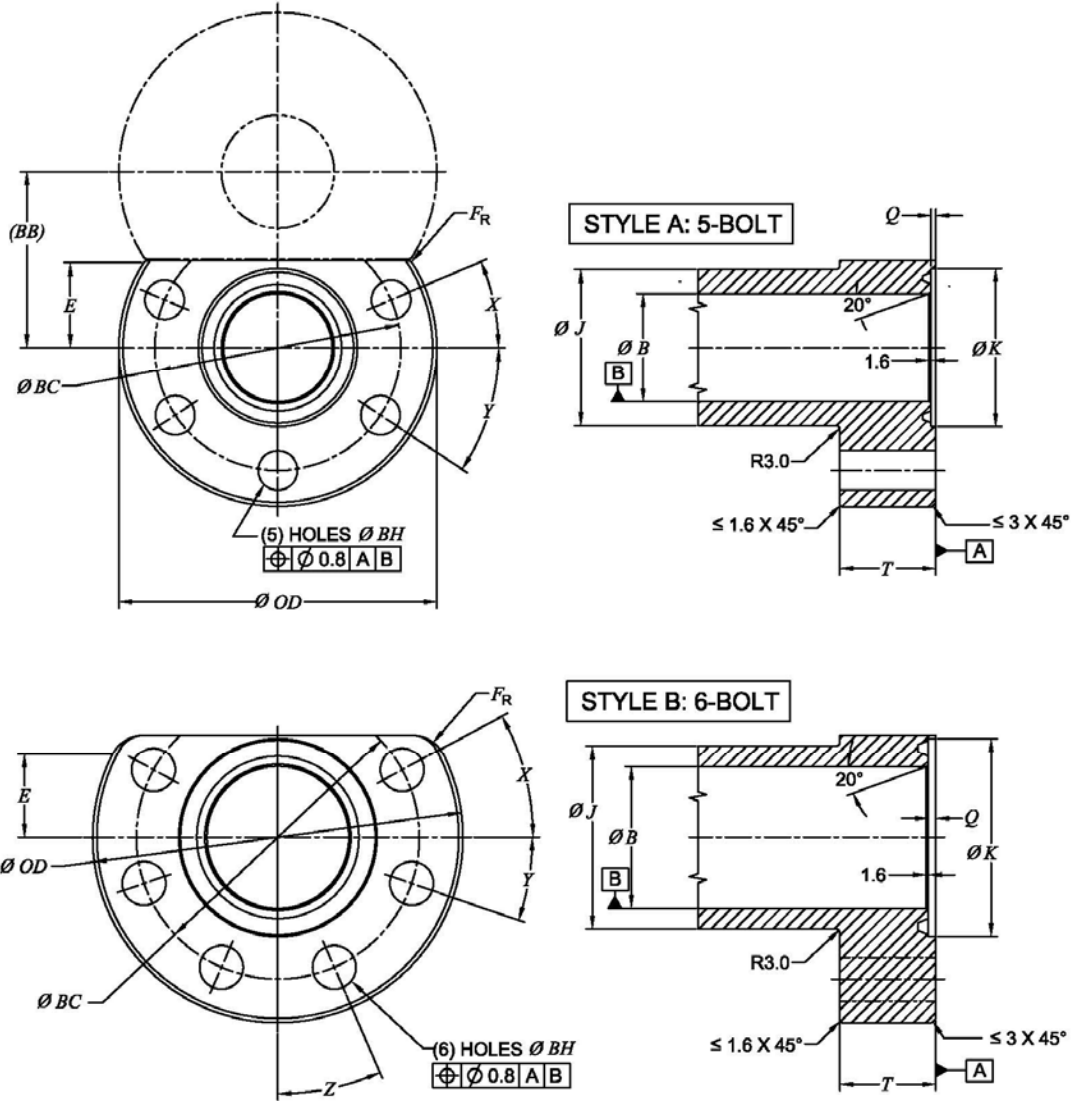

Table L.1—Dimensions for 34.5 MPa Rated Working Pressure, Segmented Flanges for Dual Completion—a) SI Units (continued)

Dimensions in millimeters unless noted otherwise

Nominal Size of Flange	Max. Bore	Outside Diameter of Flange	Total Thickness of Flange	Distance Flat to Center	Minimum Radius	Diameter of Hub	Diameter of Counterbore	Depth of Counterbore
in.	<i>B</i>	<i>OD</i>	<i>T</i>	<i>E</i>	<i>F_R</i>	<i>J</i>	<i>K</i>	<i>Q</i>
Tolerance>	max.	± 1.5	+3.0 -0	+0 -0.5	min.		+0.5 -0	+0.25 -0
1 ³ / ₈	35.3	130.0	39.6	29.5	6	56.4 +0/-0.5	52.3	2.77
1 ¹³ / ₁₆	46.5	155.4	52.3	35.1	3	69.9 +0/-0.5	66.5	1.83
2 ¹ / ₁₆	53.1	166.6	53.8	44.5	3	77.0 +0/-0.8	79.2	3.68
2 ⁹ / ₁₆	65.8	212.9	63.5	56.4	3	93.7 +0/-0.8	101.6	3.68
3 ¹ / ₈	80.3	231.6	69.9	63.5	3	114.3 +0/-0.8	115.8	3.30
4 ¹ / ₁₆	103.9	269.7	69.9	74.7	25	133.4 +0/-0.8	144.5	5.33
4 ¹ / ₁₆ X 4 ¹ / ₄	108.7	269.7	69.9	74.7	25	133.4 +0/-0.8	144.5	5.33

Dimensions in millimeters unless noted otherwise

Nominal Size of Flange	Diameter of Bolt Circle	Diameter of Bolt Holes	Number of Bolt Holes	Bolt Hole Offset	Bolt Hole Offset	Bolt Hole Offset	Bolt Size and TPI	Bore-to-bore Spacing	Stud Length, Studded x Flange	Stud Length, Flange x Flange
in.	<i>BC</i>	<i>BH</i>	<i>M</i>	<i>X</i>	<i>Y</i>	<i>Z</i>	in.	<i>BB</i>		
Tolerance>		+1.5 -0.5		See GDT	See GDT	See GDT				
1 ³ / ₈	98.6	16	5	13°	38.5°	—	1/2-13 UNC	—	70	115
1 ¹³ / ₁₆	117.3	20	5	16°	37°	—	5/8-11 UNC	70.6	90	145
2 ¹ / ₁₆	130.0	23	5	19°	35.5°	—	3/4-10 UNC	90.2	95	150
2 ⁹ / ₁₆	162.1	29	5	21°	34.5°	—	1-8 UNC	114.3	120	185
3 ¹ / ₈	179.3	29	5	23°	33.5°	—	1-8 UNC	128.3	125	195
4 ¹ / ₁₆	206.2	32	6	28.5°	19°	23.5°	1 ¹ / ₈ -8 UN	—	135	210
4 ¹ / ₁₆ X 4 ¹ / ₄	206.3	32	6	28.5°	19°	23.5°	1 ¹ / ₈ -8 UN	—	135	210

Table L.1—Dimensions for 5000 psi Rated Working Pressure, Segmented Flanges for Dual Completion (continued)

b) USC units

Dimensions in inches

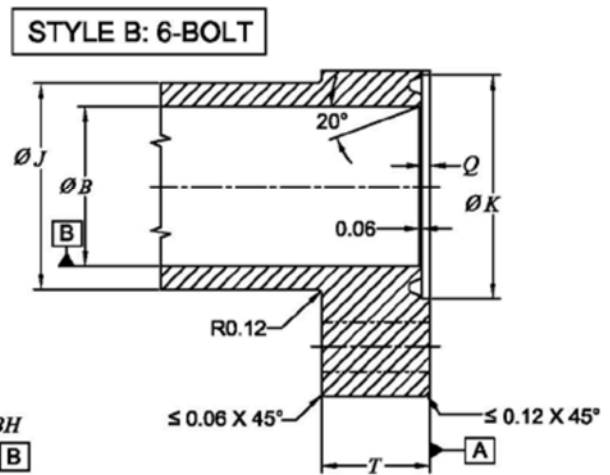
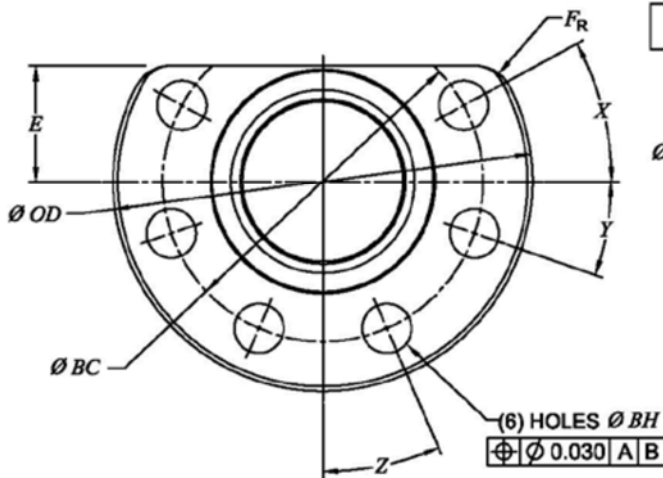
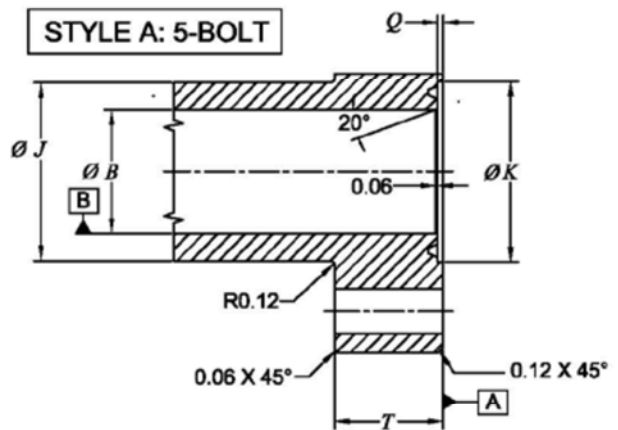
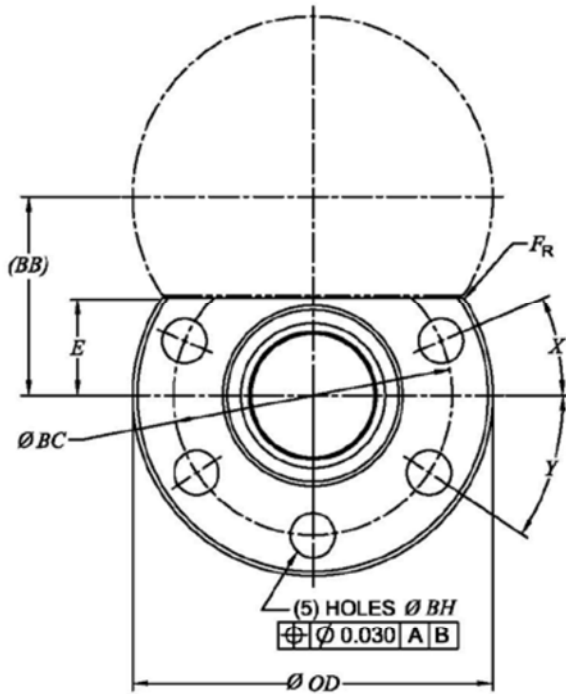

Table L.1—Dimensions for 5000 psi Rated Working Pressure, Segmented Flanges for Dual Completion—b) USC Units (continued)

Dimensions in inches

Nominal Size of Flange	Maximum Bore	Outside Diameter of Flange	Total Thickness of Flange	Distance Flat To Center	Minimum Radius	Diameter of Hub	Diameter of Counter-bore	Depth of Counter-bore
in.	<i>B</i>	<i>OD</i>	<i>T</i>	<i>E</i>	<i>F_R</i>	<i>J</i>	<i>K</i>	<i>Q</i>
Tolerance>	max.	± 0.06	+0.12 -0	0 -0.02	min.		+0.02 -0	+0.010 -0
1 ³ / ₈	1.39	5.12	1.56	1.16	0.25	2.22 +0/-0.02	2.06	0.109
1 ¹³ / ₁₆	1.83	6.12	2.06	1.38	0.12	2.75 +0/-0.02	2.62	0.072
2 ¹ / ₁₆	2.09	6.56	2.12	1.75	0.12	3.03 +0/-0.03	3.12	0.145
2 ⁹ / ₁₆	2.59	8.38	2.50	2.22	0.12	3.69 +0/-0.02	4.00	0.145
3 ¹ / ₈	3.16	9.12	2.75	2.50	0.12	4.50 +0/-0.02	4.56	0.130
4 ¹ / ₁₆	4.09	10.62	2.75	2.94	1.00	5.25 +0/-0.02	5.69	0.210
4 ¹ / ₁₆ X 4 ¹ / ₄	4.28	10.62	2.75	2.94	1.00	5.25 +0/-0.02	5.69	0.210

Dimensions in inches

Nominal Size of Flange	Diameter of Bolt Circle	Diameter of Bolt Holes	Number of Bolt Holes	Bolt Hole Offset	Bolt Hole Offset	Bolt Hole Offset	Bolt Size and TPI	Bore-to-bore Equal Size	Length of Double-ended Stud Bolt	Length of Threaded Stud Bolt
in.	<i>BC</i>	<i>BH</i>	<i>M</i>	<i>X</i>	<i>Y</i>	<i>Z</i>		<i>BB</i>		
Tolerance>	See GDT	+0.06 -0.02		See GDT	See GDT	See GDT				
1 ³ / ₈	3.88	0.62	5	13°	38.5°	—	1/2-13 UNC	—	2.75	4.50
1 ¹³ / ₁₆	4.62	0.75	5	16°	37°	—	5/8-11 UNC	2.78	3.50	5.75
2 ¹ / ₁₆	5.12	0.88	5	19°	35.5°	—	3/4-10 UNC	3.55	3.75	6.00
2 ⁹ / ₁₆	6.38	1.12	5	21°	34.5°	—	1-8 UNC	4.50	4.75	7.25
3 ¹ / ₈	7.06	1.12	5	23°	33.5°	—	1-8 UNC	5.05	5.00	7.75
4 ¹ / ₁₆	8.12	1.25	6	28.5°	19°	23.5°	1 1/8-8 UN	—	5.25	8.25
4 ¹ / ₁₆ X 4 ¹ / ₄	8.12	1.25	6	28.5°	19°	23.5°	1 1/8-8 UN	—	5.25	8.25

Table L.2—Dimensions for Type RX Ring Grooves and Ring Gasket Used on Segmented Flanges for Dual Completion

a) SI units

Dimensions in millimeters; surface roughness in micrometers

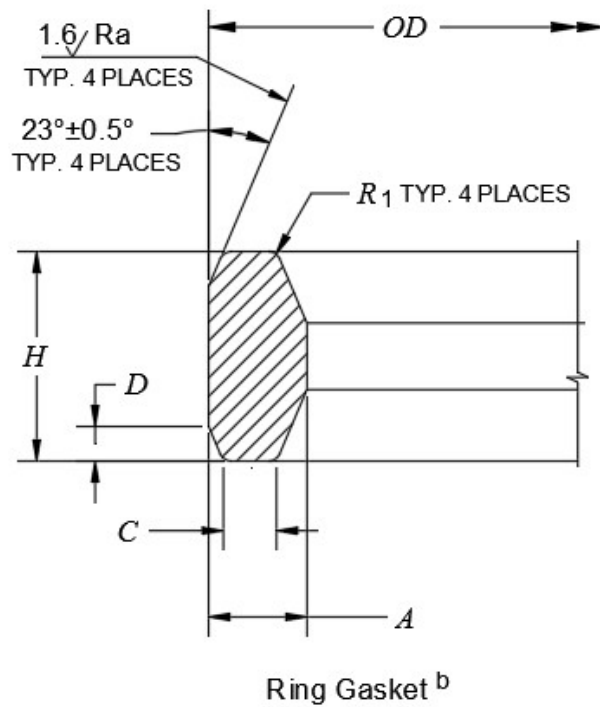
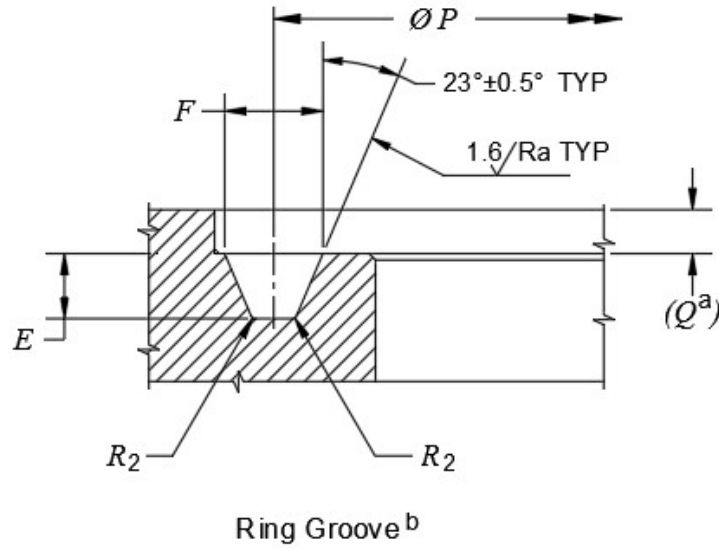

FOOTNOTES

^a Counterbore—see Table L.1 a).

^b Groove and gasket shown rotated 90 degrees with respect to Table L.1 a).

Table L.2—Dimensions for Type RX Ring Grooves and Ring Gasket Used on Segmented Flanges for Dual Completion—a) SI Units (continued)**Ring Grooves**

Dimensions in millimeters unless noted otherwise

Ring Number	Nominal Size of Flange	Pitch Diameter of Groove	Depth of Groove	Width of Groove	Radius in Groove
RX	in.	<i>P</i>	<i>E</i>	<i>F</i>	<i>R</i> ₂
Tolerance>		± 0.13	+0.5 -0	± 0.20	max.
20	2 ¹ / ₁₆	68.28	6.4	8.74	0.8
25	3 ¹ / ₈	101.6	6.4	8.74	0.8
201	1 ³ / ₈	46.05	4.1	5.56	0.8
205	1 ¹³ / ₁₆	57.15	4.1	5.56	0.5
210	2 ⁹ / ₁₆	88.90	6.4	9.53	0.8
215	4 ¹ / ₁₆	130.18	7.9	11.91	0.8

Ring Gaskets

Dimensions in millimeters

Ring Number	Outside Diameter of Ring	Width of Ring	Width of Flat	Height of Outside Bevel	Height of Ring	Radius on Ring
RX	<i>OD</i>	<i>A</i>	<i>C</i>	<i>D</i>	<i>H</i>	<i>R</i> ₁
Tolerance>	+0.5 -0	+0.20 -0	+0.15 -0		+0.2 -0	
20	76.20	8.74	4.62	3.18 +0/-0.8	19.05	1.5 ± 0.5
25	109.55	8.74	4.62	3.18 +0/-0.8	19.05	1.5 ± 0.5
201	51.46	5.74	3.20	1.45 +0/-0.38	11.30	0.5 +0.5/-0
205	62.31	5.56	3.05	1.83 +0/-0.38	11.10	0.5 +0.5/-0
210	97.64	9.53	5.41	3.18 +0/-0.38	19.05	0.8 +0.5/-0
215	140.89	11.91	5.33	4.24 +0/-0.38	25.40	1.5 +0.5/-0

Table L.2—Dimensions for Type RX Ring Grooves and Ring Gaskets Used on Segmented Flanges for Dual Completion (continued)

b) USC units

Dimensions in inches; surface roughness in microinches

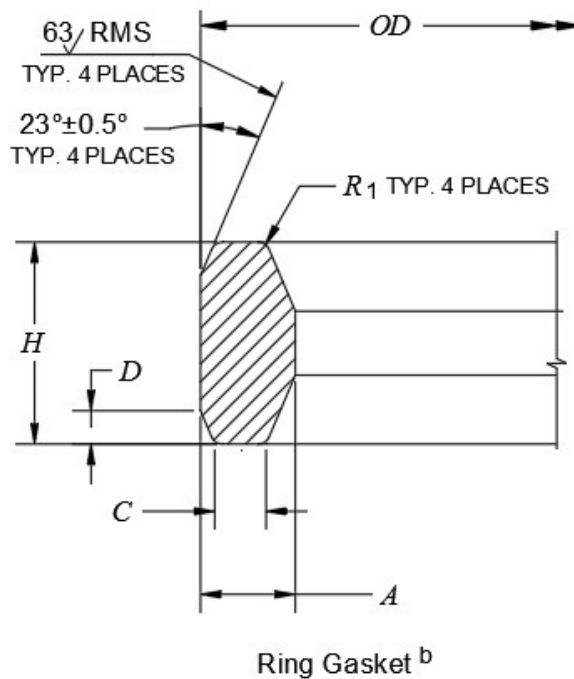
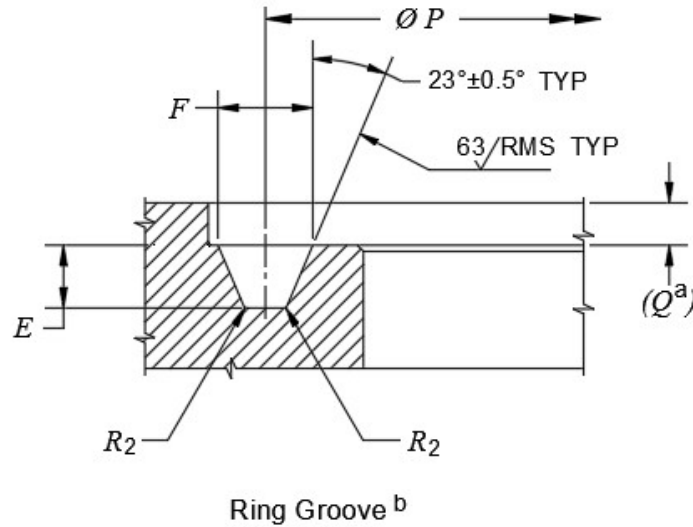

FOOTNOTES

^a Counterbore—see Table L.1 b).

^b Groove and gasket shown rotated 90 degrees with respect to Table L.1 b).

Table L.2—Dimensions for Type RX Ring Grooves and Ring Gaskets Used on Segmented Flanges for Dual Completion—b) USC Units (continued)**Ring Grooves**

Dimensions in inches

Ring Number	Nominal Size of Flange	Pitch Diameter of Groove	Depth of Groove	Width of Groove	Radius in Groove
RX	in.	<i>P</i>	<i>E</i>	<i>F</i>	<i>R</i> ₂
Tolerance>		± 0.005	+0.02 -0	± 0.008	max.
20	2 ¹ / ₁₆	2.688	0.25	0.344	0.03
25	3 ¹ / ₈	4.000	0.25	0.344	0.03
201	1 ³ / ₈	1.813	0.16	0.219	0.03
205	1 ¹³ / ₁₆	2.250	0.16	0.219	0.02
210	2 ⁹ / ₁₆	3.500	0.25	0.375	0.03
215	4 ¹ / ₁₆	5.125	0.31	0.469	0.03

Ring Gaskets

Dimensions in inches

Ring Number	Outside Diameter of Ring	Width of Ring	Width of Flat	Height of Outside Bevel	Height of Ring	Radius on Ring
RX	<i>OD</i>	<i>A</i>	<i>C</i>	<i>D</i>	<i>H</i>	<i>R</i> ₁
Tolerance>	+0.02 -0	+0.008 -0	+0.006 -0		+0.008 -0	
20	3.000	0.344	0.182	0.125 +0/-0.03	0.750	0.06 ± 0.02
25	4.313	0.344	0.182	0.125 +0/-0.03	0.750	0.06 ± 0.02
201	2.026	0.226	0.126	0.057 +0/-0.015	0.445	0.02 +0.02/-0
205	2.453	0.219	0.120	0.072 +0/-0.015	0.437	0.02 +0.02/-0
210	3.844	0.375	0.213	0.125 +0/-0.015	0.750	0.03 +0.02/-0
215	5.547	0.469	0.210	0.167 +0/-0.015	1.000	0.05 +0.02/-0

Annex M (normative)

Heat-treat Equipment Survey

M.1 Temperature Survey Method for Batch-type Furnaces

The furnace working zone shall be defined by the manufacturer. A temperature survey within the furnace working zone(s) shall be performed on each furnace at the maximum and minimum temperatures for which each furnace is being used.

For furnaces having a working zone less than or equal to 0.3 m³ (10 ft³), a minimum of three thermocouples located either at the front, center and rear, or at the top, center and bottom of the furnace working zone shall be used.

For furnaces having a working zone greater than 0.3 m³ (10 ft³) and not greater than 31.5 m³ (1125 ft³), a minimum of nine thermocouples shall be used. For each additional 3.5 m³ (125 ft³) beyond 31.5 m³ (1125 ft³) of furnace working zone surveyed, at least one additional thermocouple shall be used, up to a total of 40 thermocouples. The first nine thermocouples shall be located as per Figure M.1 and Figure M.2. Each additional thermocouple location shall be equally spaced in the central additional working zone volume.

After insertion of the temperature-sensing devices, readings shall be taken at least once every three minutes to determine when the temperature of the furnace working zone approaches the bottom of the temperature range being surveyed.

Once the furnace temperature has reached the set-point temperature, the temperature of all test locations shall be recorded at two-minute intervals, maximum, for at least 10 min. Then, readings shall be taken at five-minute intervals, maximum, for sufficient time (at least 30 min) to determine the recurrent temperature pattern of the furnace working zone.

M.2 Temperature Survey Method for Continuous-type Furnaces

Furnaces used for continuous heat-treatment shall be validated in accordance with procedures specified in SAE AMS2750 or SAE AMS-H-6875.

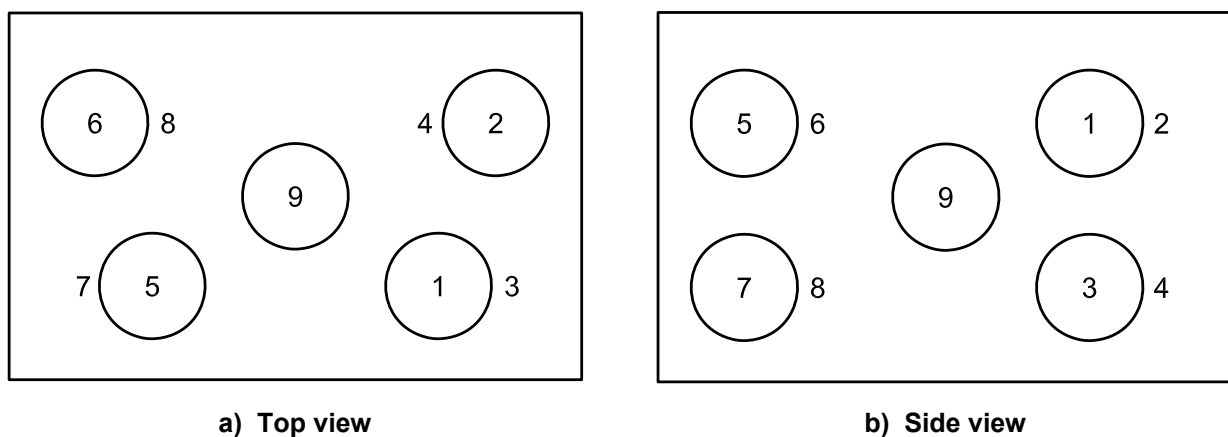

Figure M.1—Thermocouple Locations—Rectangular Furnace (Working Zone)

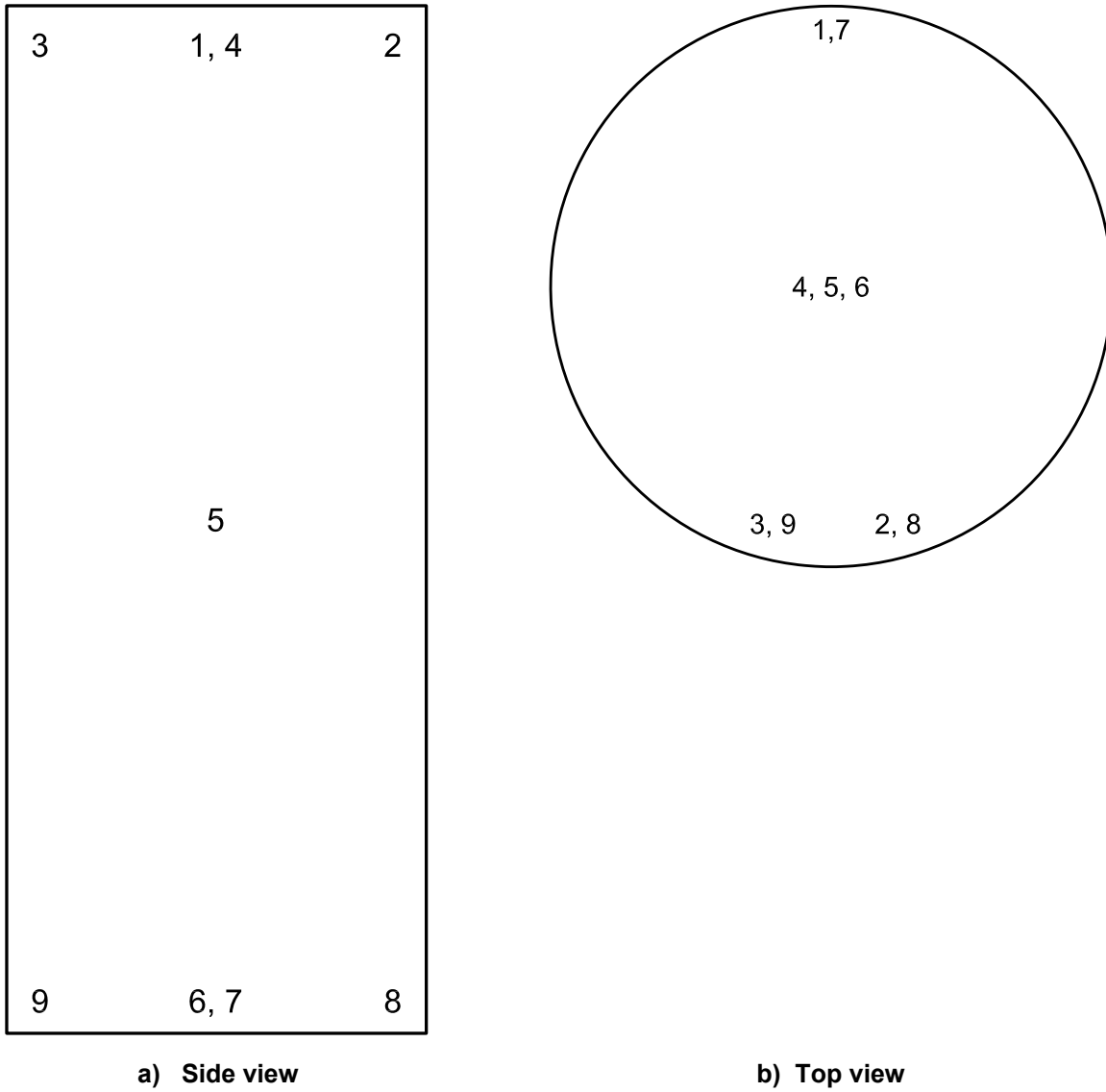

Figure M.2—Thermocouple Locations—Cylindrical Furnace (Working Zone)

Bibliography

- [1] API Specification 5L, *Line Pipe*
- [2] API Technical Report 6AF, *Technical Report on Capabilities of API Flanges Under Combinations of Load*
- [3] API Technical Report 6AF1, *Technical Report on Temperature Derating of API Flanges under Combination of Loading*
- [4] API Technical Report 6AF2, *Technical Report on Capabilities of API Integral Flanges under Combination of Loading—Phase II*
- [5] API Standard 6AV2, *Installation, Maintenance, and Repair of Surface Safety Valves and Underwater Safety Valves Offshore*
- [6] API Standard 6FA, *Standard for Fire Test for Valves*
- [7] API Specification 6FB, *Specification for Fire Test for End Connectors*
- [8] API Specification 6FD, *Specification for Fire Test for Check Valves*
- [9] API Recommended Practice 6HT, *Heat Treatment and Testing of Carbon and Low Alloy Steel Large Cross Section and Critical Section Components*
- [10] API Technical Report 6MET, *Metallic Material Limits for Wellhead Equipment Used in High Temperature for API 6A and 17D Applications*
- [11] API Specification 7-1, *Specification for Rotary Drill Stem Elements*
- [12] API Recommended Practice 17C, *Recommended Practice on TFL (Through Flowline) Systems*
- [13] API Technical Report 17TR8, *High-pressure High-temperature Design Guidelines*
- [14] API Specification 20B, *Open Die Shaped Forgings for Use in the Petroleum and Natural Gas Industry*
- [15] API Specification 20C, *Closed Die Forgings for Use in the Petroleum and Natural Gas Industry*
- [16] API Standard 20D, *Nondestructive Examination Services for Equipment Used in the Petroleum and Natural Gas Industry*
- [17] API Standard 20H, *Heat Treatment Services—Batch Type for Equipment Used in the Petroleum and Natural Gas Industry*
- [18] ASME B16.34, *Valves—Flanged, Threaded, and Welding End*
- [19] ASME B18.2.2, *Nuts for General Applications: Machine Screw Nuts, Hex, Square, Hex Flange, and Coupling Nuts (Inch Series)*
- [20] ASME Boiler and Pressure Vessel Code:2004 with 2005 and 2006 addenda, *Section II, Materials*
- [21] ASME Boiler and Pressure Vessel Code:2004 with 2005 and 2006 addenda, *Section VIII, Division 3, Alternative Rules for Construction of High Pressure Vessels*

-
- [22] ASME SPPE 1, *Quality Assurance and Certification of Safety and Pollution Prevention Equipment Used in Offshore Oil and Gas Operations*⁷
 - [23] ASME PCC-1, *Guidelines for Pressure Boundary Bolted Flange Joint Assembly*
 - [24] ASTM E21, *Standard Test Methods for Elevated Temperature Tension Tests of Metallic Materials*
 - [25] ASTM E94/E94M, *Standard Guide for Radiographic Examination Using Industrial Radiographic Film*
 - [26] ASTM E747, *Standard Practice for Design, Manufacture and Material Grouping Classification of Wire Image Quality Indicators (IQI) Used for Radiology*
 - [27] ISO 80000-1, *Quantities and units—Part 1: General*
 - [28] Texas Administrative Code, *Title 16 Economic Regulation, Part 1 Railroad Commission of Texas, Chapter 3 Oil and Gas Division*

⁷ Out of print; included to deal with old equipment made to obsolete standards.



200 Massachusetts Avenue, NW
Suite 1100
Washington, DC 20001-5571
USA

202-682-8000

Additional copies are available online at www.api.org/pubs

Phone Orders: 1-800-854-7179 (Toll-free in the U.S. and Canada)
303-397-7956 (Local and International)

Fax Orders: 303-397-2740

Information about API publications, programs and services is available
on the web at www.api.org.

Product No. GX06A21