

INTERNATIONAL
STANDARD

ISO
37

Fourth edition
2005-07-15

**Rubber, vulcanized or thermoplastic —
Determination of tensile stress-strain
properties**

*Caoutchouc vulcanisé ou thermoplastique — Détermination des
caractéristiques de contrainte-déformation en traction*



Reference number
ISO 37:2005(E)



PDF disclaimer

This PDF file may contain embedded typefaces. In accordance with Adobe's licensing policy, this file may be printed or viewed but shall not be edited unless the typefaces which are embedded are licensed to and installed on the computer performing the editing. In downloading this file, parties accept therein the responsibility of not infringing Adobe's licensing policy. The ISO Central Secretariat accepts no liability in this area.

Adobe is a trademark of Adobe Systems Incorporated.

Details of the software products used to create this PDF file can be found in the General Info relative to the file; the PDF-creation parameters were optimized for printing. Every care has been taken to ensure that the file is suitable for use by ISO member bodies. In the unlikely event that a problem relating to it is found, please inform the Central Secretariat at the address given below.

© ISO 2005

All rights reserved. Unless otherwise specified, no part of this publication may be reproduced or utilized in any form or by any means, electronic or mechanical, including photocopying and microfilm, without permission in writing from either ISO at the address below or ISO's member body in the country of the requester.

ISO copyright office
Case postale 56 • CH-1211 Geneva 20
Tel. + 41 22 749 01 11
Fax + 41 22 749 09 47
E-mail copyright@iso.org
Web www.iso.org

Published in Switzerland



Contents

Page

Foreword.....	iv
1 Scope	1
2 Normative references	1
3 Terms and definitions.....	1
4 Principle.....	3
5 General.....	4
6 Test pieces	5
7 Apparatus	6
8 Number of test pieces	7
9 Preparation of test pieces.....	7
10 Conditioning of sample and test pieces.....	8
11 Marking of dumb-bell test pieces.....	8
12 Measurement of test pieces.....	9
13 Procedure	9
14 Temperature of test	10
15 Calculation of results	10
16 Expression of results	12
17 Test report	13
Annex A (informative) Preparation of type B ring test pieces	14
Annex B (informative) Precision	17
Annex C (informative) Analysis of ITP data and dumb-bell shape.....	21
Bibliography	25



Foreword

ISO (the International Organization for Standardization) is a worldwide federation of national standards bodies (ISO member bodies). The work of preparing International Standards is normally carried out through ISO technical committees. Each member body interested in a subject for which a technical committee has been established has the right to be represented on that committee. International organizations, governmental and non-governmental, in liaison with ISO, also take part in the work. ISO collaborates closely with the International Electrotechnical Commission (IEC) on all matters of electrotechnical standardization.

International Standards are drafted in accordance with the rules given in the ISO/IEC Directives, Part 2.

The main task of technical committees is to prepare International Standards. Draft International Standards adopted by the technical committees are circulated to the member bodies for voting. Publication as an International Standard requires approval by at least 75 % of the member bodies casting a vote.

Attention is drawn to the possibility that some of the elements of this document may be the subject of patent rights. ISO shall not be held responsible for identifying any or all such patent rights.

ISO 37 was prepared by Technical Committee ISO/TC 45, *Rubber and rubber products*, Subcommittee SC 2, *Testing and analysis*.

This fourth edition cancels and replaces the third edition (ISO 37:1994).

The major changes incorporated in this revision are as follows:

- The addition of a new dumb-bell test piece designated type 1A.
- The addition of a new annex, Annex B, with precision data on type 1, type 2 and type 1A test pieces.
- The addition of a new annex, Annex C, with an analysis of the dependence of the precision data on dumb-bell test piece shape.



Rubber, vulcanized or thermoplastic — Determination of tensile stress-strain properties

1 Scope

This International Standard describes a method for the determination of the tensile stress-strain properties of vulcanized and thermoplastic rubbers.

The properties which can be determined are tensile strength, elongation at break, stress at a given elongation, elongation at a given stress, stress at yield and elongation at yield. The measurement of stress and strain at yield applies only to some thermoplastic rubbers and certain other compounds.

2 Normative references

The following referenced documents are indispensable for the application of this document. For dated references, only the edition cited applies. For undated references, the latest edition of the referenced document (including any amendments) applies.

ISO 5893, *Rubber and plastics test equipment — Tensile, flexural and compression types (constant rate of traverse) — Specification*

ISO 23529:2004, *Rubber — General procedures for preparing and conditioning test pieces for physical test methods*

3 Terms and definitions

For the purposes of this document, the following terms and definitions apply.

3.1 tensile stress

S

stress applied so as to extend the test piece

NOTE It is calculated as the applied force per unit area of the original cross-section of the test length.

3.2 elongation

E

tensile strain, expressed as a percentage of the test length, produced in the test piece by a tensile stress

3.3 tensile strength

TS

maximum tensile stress recorded in extending the test piece to breaking point

NOTE See Figures 1a) to 1c).



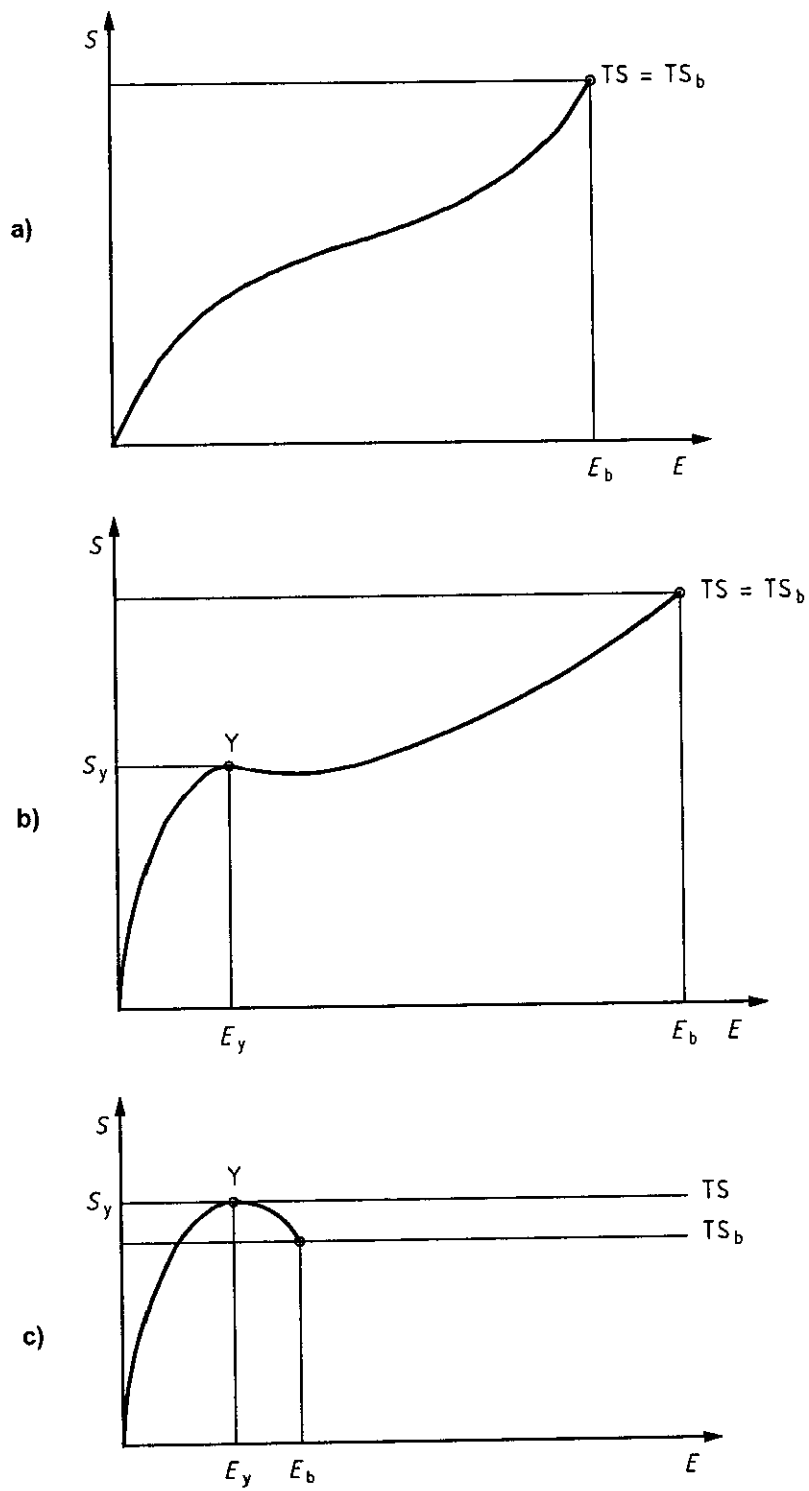

Key

- | | | | |
|-------|---------------------|--------|---------------------------|
| E | elongation | S_y | stress at yield |
| E_b | elongation at break | TS | tensile strength |
| E_y | elongation at yield | TS_b | tensile strength at break |
| S | stress | Y | yield point |

Figure 1 — Illustration of tensile terms



3.4**tensile strength at break****TS_b**

tensile stress recorded at the moment of rupture

NOTE 1 See Figures 1a) to 1c).

NOTE 2 The values of TS and TS_b may be different if, after yield at S_y , the elongation continues and is accompanied by a drop in stress, resulting in TS_b being lower than TS [see Figure 1c)].**3.5****elongation at break****E_b**

tensile strain in the test length at breaking point

NOTE See Figures 1a) to 1c).

3.6**elongation at a given stress****E_s**

tensile strain in the test length when the test piece is subjected to a given tensile stress

3.7**stress at a given elongation****S_e**

tensile stress in the test length required to produce a given elongation

NOTE In the rubber industry, this definition is widely identified with the term "modulus", and care should be taken to avoid confusion with the other use of "modulus" to denote the slope of the stress-strain curve at a given elongation.

3.8**tensile stress at yield****S_y**

tensile stress at the first point on the stress-strain curve where some further increase in strain occurs without any increase in stress

NOTE This may correspond to either a point of inflection [see Figure 1b)] or to a maximum [see Figure 1c)].

3.9**elongation at yield****E_y**

tensile strain at the first point on the stress-strain curve where some further increase in strain is not accompanied by an increase in stress

NOTE See Figures 1b) and 1c).

3.10**test length of a dumb-bell**

initial distance between reference points within the length of the narrow portion of a dumb-bell test piece used to measure elongation

NOTE See Figure 2.

4 Principle

Standard test pieces, either dumb-bells or rings, are stretched in a tensile-testing machine at a constant rate of traverse of the driven grip or pulley. Readings of force and elongation are taken as required during the uninterrupted stretching of the test piece and when it breaks.



5 General

Dumb-bell and ring test pieces do not necessarily give the same values for their respective stress-strain properties. This is mainly because in stretched rings the stress is not uniform over the cross-section. A second factor is in the existence of "grain" which may cause dumb-bells to give different values depending whether their length is parallel or at right angles to the grain.

The main points to be noted in choosing between rings and dumb-bells are as follows:

a) Tensile strength

Dumb-bells are preferable for determination of tensile strength. Rings give lower, sometimes much lower, values than dumb-bells.

b) Elongation at break

Rings give approximately the same values as dumb-bells, provided that

- 1) the elongation of rings is calculated as a percentage of the initial internal circumference and
- 2) dumb-bells are cut at right angles to the grain if this is present to a significant degree.

Dumb-bells shall be used if it is required to study grain effects for which rings are not suitable.

c) Elongation at a given stress and stress at a given elongation

The larger dumb-bells (types 1, 2 and 1A) are generally preferred.

Rings and dumb-bells give approximately the same values provided that

- 1) the elongation of rings is calculated as a percentage of the initial mean circumference and
- 2) the average value is taken for dumb-bells cut parallel and at right angles to the grain if this is present to a significant degree.

Rings may be preferred in automated testing, due to the ease of handling of the test pieces, and in the determination of stress at a given strain.

d) Miniature test pieces may give somewhat different, usually higher, values for tensile strength and elongation at break than the larger test pieces.

Seven types of test piece are provided, i.e. dumb-bell-shaped types 1, 2, 3, 4 and 1A and ring-shaped types A (normal) and B (miniature). The results obtained for a given material are likely to vary according to the type of test piece used, and the results obtained for different materials should therefore not be regarded as comparable unless the same type of test piece has been used.

Type 3 and 4 dumb-bell test pieces and type B ring test pieces shall only be used where insufficient material is available for the larger test pieces. These test pieces are particularly suitable for testing products and are used in certain product standards, e.g. type 3 dumb-bells have been used for testing pipe sealing rings and cables.

When preparation of test pieces requires buffing or thickness adjustment, results may be affected.



6 Test pieces

6.1 Dumb-bells

Dumb-bell test pieces shall have the outline shown in Figure 2.

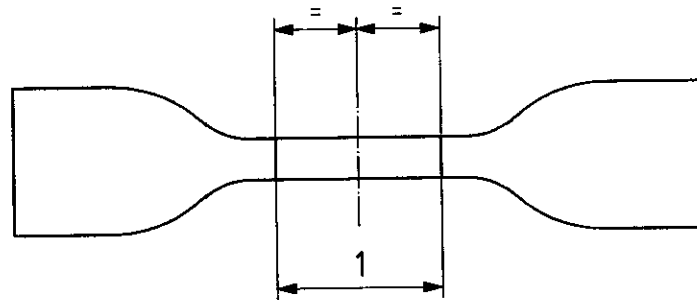

Key

1 test length (see Table 1)

Figure 2 — Shape of dumb-bell test pieces

The standard thickness of the narrow portion shall be $2,0 \text{ mm} \pm 0,2 \text{ mm}$ for types 1, 2, 3 and 1A and $1,0 \text{ mm} \pm 0,1 \text{ mm}$ for type 4.

The test length shall be in accordance with Table 1.

The other dimensions of the dumb-bells shall be as produced by the appropriate die (see Table 2).

For non-standard test pieces, e.g. those taken from finished products, the maximum thickness of the narrow portion shall be $3,0 \text{ mm}$ for types 1 and 1A, $2,5 \text{ mm}$ for types 2 and 3, and $2,0 \text{ mm}$ for type 4.

Table 1 — Test length of dumb-bells

Type of test piece	Type 1	Type 1A	Type 2	Type 3	Type 4
Test length (mm)	$25 \pm 0,5$	$20 \pm 0,5^a$	$20 \pm 0,5$	$10 \pm 0,5$	$10 \pm 0,5$
^a The test length shall not exceed the length of narrow portion of the test piece (dimension C in Table 2).					

6.2 Rings

The standard type A ring test piece shall have an internal diameter of $44,6 \text{ mm} \pm 0,2 \text{ mm}$. The median axial thickness and median radial width shall be $4 \text{ mm} \pm 0,2 \text{ mm}$. The radial width within any ring shall nowhere deviate from the median by more than $0,2 \text{ mm}$ and the axial thickness within the ring shall nowhere deviate from the median by more than 2% .

The standard type B ring test piece shall have an internal diameter of $8 \text{ mm} \pm 0,1 \text{ mm}$. The median axial thickness and median radial width shall be $1 \text{ mm} \pm 0,1 \text{ mm}$. The radial width within any ring shall nowhere deviate from the median by more than $0,1 \text{ mm}$.



7 Apparatus

7.1 Dies and cutters

All dies and cutters used shall be in accordance with ISO 23529. Dies for preparation of dumb-bells shall have the dimensions given in Table 2 and Figure 3. The departure from parallelism at any point along the width of the narrow portion of the die shall nowhere exceed 0,05 mm.

For a method of cutting type B ring test pieces, see Annex A.

7.2 Thickness gauge

The instrument for measuring the thickness of dumb-bell test pieces and the axial thickness of ring test pieces shall be in accordance with that used in method A of ISO 23529:2004.

The instrument for measuring the radial width of ring test pieces shall be similar to the above, except that the contact and base plate shall be shaped to fit the curvature of the ring.

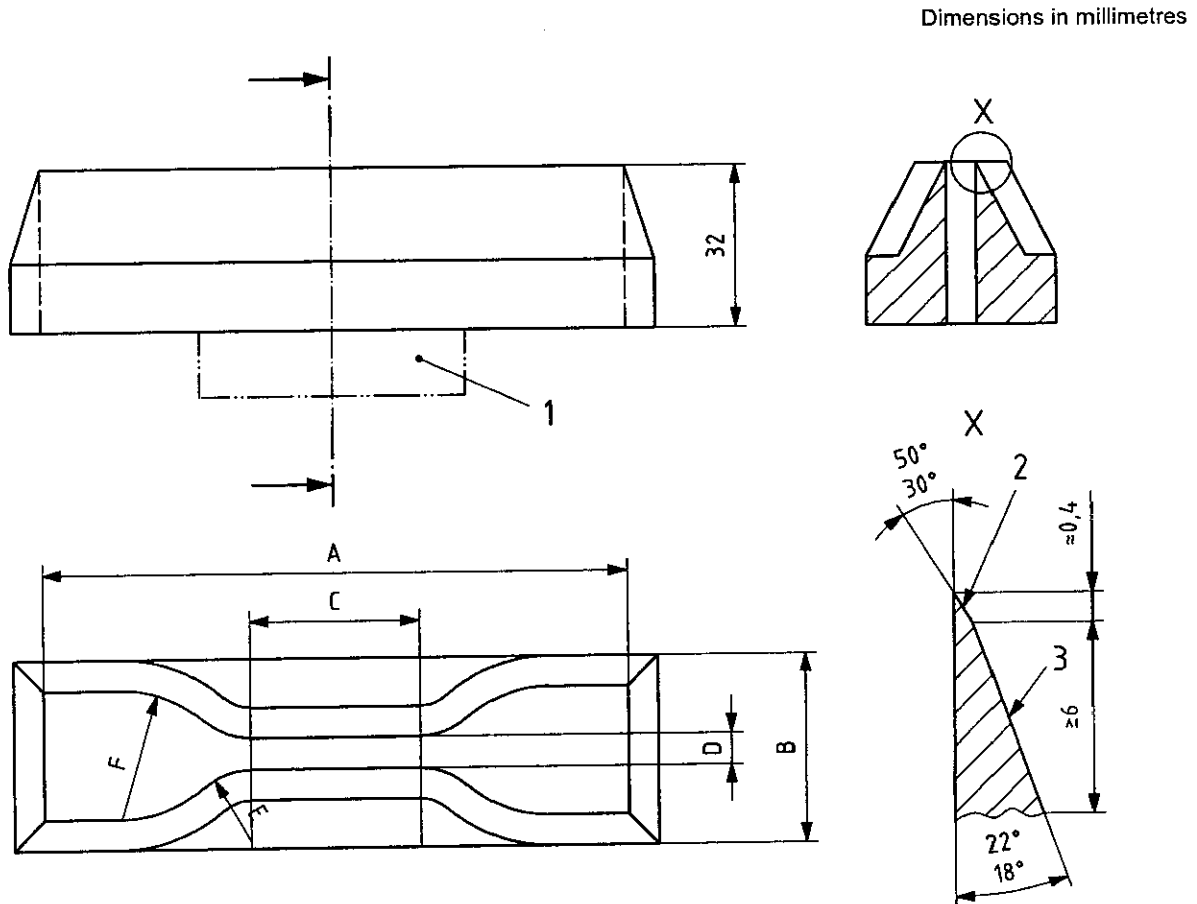

Key

- 1 method of fixing to suit machine
- 2 ground smooth
- 3 ground

NOTE For dimensions A to F, see Table 2.

Figure 3 — Die for dumb-bell test pieces



Table 2 — Dimensions of dies for dumb-bell test pieces

Dimension	Type 1	Type 1A	Type 2	Type 3	Type 4
A Overall length (minimum) ^a (mm)	115	100	75	50	35
B Width of ends (mm)	25,0 ± 1	25,0 ± 1	12,5 ± 1	8,5 ± 0,5	6 ± 0,5
C Length of narrow portion (mm)	33 ± 2	20 ⁺² / ₀	25 ± 1	16 ± 1	12 ± 0,5
D Width of narrow portion (mm)	6 ^{+0,4} / ₀	5 ± 0,1	4 ± 0,1	4 ± 0,1	2 ± 0,1
E Transition radius outside (mm)	14 ± 1	11 ± 1	8 ± 0,5	7,5 ± 0,5	3 ± 0,1
F Transition radius inside (mm)	25 ± 2	25 ± 2	12,5 ± 1	10 ± 0,5	3 ± 0,1

^a A greater overall length may be necessary to ensure that only the wide end tabs come into contact with the machine grips, thus avoiding "shoulder breaks".

7.3 Cone gauge

A calibrated cone gauge or other suitable equipment shall be used to measure the internal diameter of ring test pieces. The equipment shall be capable of measuring the diameter with an error of not more than 0,01 mm. The means of supporting the ring test piece to be measured shall be such as to avoid any significant change in the dimension being measured.

7.4 Tensile-testing machine

7.4.1 The tensile-testing machine shall comply with the requirements of ISO 5893, having an accuracy of force measurement complying with class 2. An extensometer, where used, shall have an accuracy complying with class D for type 1, 2 and 1A dumb-bell and type A ring test pieces, and class E for type 3 and 4 dumb-bell and type B ring test pieces. The machine shall, as a minimum, be capable of operating at rates of traverse of 100 mm/min, 200 mm/min and 500 mm/min.

7.4.2 For tests at temperatures other than standard laboratory temperature, a suitable thermostatically controlled chamber shall be fitted to the tensile-testing machine. Guidance for achieving elevated or subnormal temperatures is given in ISO 23529.

8 Number of test pieces

A minimum of three test pieces shall be tested.

NOTE The number of test pieces should be decided in advance and the use of five test pieces will give a lower uncertainty than a test with three test pieces.

9 Preparation of test pieces

9.1 Dumb-bells

Dumb-bell test pieces shall be prepared by the appropriate methods described in ISO 23529. Dumb-bells shall, wherever possible, be cut parallel to the grain of the material unless grain effects are to be studied, in which case a set of dumb-bells shall also be cut perpendicular to the grain.

9.2 Rings

Ring test pieces shall be prepared by cutting or punching, using the appropriate methods described in ISO 23529, or by moulding.



10 Conditioning of sample and test pieces

10.1 Time between vulcanization and testing

For all test purposes, the minimum time between vulcanization and testing shall be 16 h.

For non-product tests the maximum time between vulcanization and testing shall be 4 weeks and, for evaluations intended to be comparable, the tests, as far as possible, shall be carried out after the same time interval.

For product tests, whenever possible, the time between vulcanization and testing shall not exceed 3 months. In other cases, tests shall be made within 2 months of the date of receipt of the product by the customer.

10.2 Protection of samples and test pieces

Samples and test pieces shall be protected as completely as possible from all external influences likely to cause damage during the interval between vulcanization and testing, e.g. they shall be protected from light and heat.

10.3 Conditioning of samples

Condition all samples, other than those from latex, in accordance with ISO 23529 at standard laboratory temperature, without humidity control, for not less than 3 h prior to cutting out the test pieces.

Condition all prepared latex samples in accordance with ISO 23529 at standard laboratory temperature, with humidity control, for not less than 96 h prior to cutting out the test pieces.

10.4 Conditioning of test pieces

Condition all test pieces in accordance with ISO 23529. If the preparation of test pieces involves buffing, the interval between buffing and testing shall be not less than 16 h and not greater than 72 h.

For tests at standard laboratory temperature, test pieces that do not require further preparation may be tested immediately, if cut from conditioned test samples. Where additional preparation is involved, a minimum conditioning period of 3 h at standard laboratory temperature shall be allowed.

For tests at temperatures other than standard laboratory temperature, condition the test pieces at the temperature at which the test is to be conducted for a period sufficient to enable the test pieces to attain substantial equilibrium in accordance with ISO 23529 (see also 7.4.2).

11 Marking of dumb-bell test pieces

If using a non-contact extensometer, mark the dumb-bell test pieces with two reference marks to define the test length as specified in Table 1, using a suitable marker. The test piece shall be unstrained when it is marked.

The lines shall be marked on the narrow part of the test piece, as shown in Figure 2, i.e. equidistant from the centre of the test piece and at right angles to its longitudinal axis.



12 Measurement of test pieces

12.1 Dumb-bells

Measure the thickness at the centre and at each end of the test length with the thickness gauge. The median value of the three measurements shall be used in calculating the area of the cross-section. In any one dumb-bell, none of the three thickness measurements of the narrow portion shall differ by more than 2 % from the median thickness. The width of the test piece shall be taken as the distance between the cutting edges of the die in the narrow part, and this distance shall be measured in accordance with ISO 23529 to the nearest 0,05 mm.

12.2 Rings

Measure the radial width and axial thickness at six approximately equally spaced positions around the ring. The median value of each set of measurements shall be used in calculating the area of the cross-section. The internal diameter shall be measured to the nearest 0,1 mm. Calculate the internal circumference and the mean circumference as follows:

$$\text{Internal circumference} = \pi \times \text{internal diameter}$$

$$\text{Mean circumference} = \pi \times (\text{internal diameter} + \text{radial width})$$

12.3 Median thickness

In any one dumb-bell, none of the three thickness measurements of the narrow portion shall differ by more than 2 % from the median thickness. If two groups of test pieces are being compared, the median thickness of each group shall be within 7,5 % of the median thickness of the two groups.

13 Procedure

13.1 Dumb-bell test pieces

Insert the test piece into the tensile-testing machine, ensuring that the end tabs are gripped symmetrically so that the tension is distributed uniformly over the cross-section. If necessary, set up the extensometry device. Start the machine and monitor continuously the change in test length and force throughout the test to an accuracy within ± 2 % or as required for the purposes of Clause 15.

The nominal rate of traverse of the moving grip shall be 500 mm/min for type 1, type 2 and type 1A test pieces and 200 mm/min for type 3 and type 4 test pieces.

Any test piece that breaks outside the narrow portion or yields outside the test length (see Figure 2) shall be discarded and a repeat test conducted on an additional test piece.

NOTE In making visual measurements, care should be taken to avoid inaccuracies due to parallax.

13.2 Ring test pieces

Place the test piece with a minimum of tension around the two pulleys. Start the machine and monitor continuously the distance between the pulleys and the increase in stress throughout the test to an accuracy of ± 2 % or as required for the purposes of Clause 15.

The nominal rate of traverse of the moving pulley shall be 500 mm/min for type A test pieces and 100 mm/min for type B test pieces.



14 Temperature of test

The test shall normally be carried out at one of the standard laboratory temperatures specified in ISO 23529. When other temperatures are required, these shall be selected from the list of preferred temperatures given in ISO 23529.

The same temperature shall be used throughout any one test or series of tests intended to be comparable.

15 Calculation of results

15.1 Dumb-bells

Calculate the tensile strength TS, expressed in megapascals, using the equation

$$TS = \frac{F_m}{W_t}$$

Calculate the tensile strength at break TS_b , expressed in megapascals, using the equation

$$TS_b = \frac{F_b}{W_t}$$

Calculate the elongation at break E_b , expressed as a percentage, using the equation

$$E_b = \frac{100(L_b - L_0)}{L_0}$$

Calculate the stress at a given elongation, S_e , expressed in megapascals, using the equation

$$S_e = \frac{F_e}{W_t}$$

Calculate the elongation at a given stress, E_s , expressed as a percentage, using the equation

$$E_s = \frac{100(L_s - L_0)}{L_0}$$

The value, in newtons, of the force F_e corresponding to the required stress is calculated using the equation

$$F_e = S_e W_t$$

Calculate the tensile stress at yield S_y , expressed in megapascals, from the force recorded at the yield point, using the equation

$$S_y = \frac{F_y}{W_t}$$

Calculate the elongation at yield E_y , expressed as a percentage, using the equation

$$E_y = \frac{100(L_y - L_0)}{L_0}$$



In the equations given above, the symbols used have the following meanings:

- F_b is the force recorded at break, in newtons;
- F_e is the force recorded at the given strain, in newtons;
- F_m is the maximum force recorded, in newtons;
- F_y is the force recorded at yield, in newtons;
- L_0 is the initial test length, in millimetres;
- L_b is the test length at break, in millimetres;
- L_s is the test length at a given stress, in millimetres;
- L_y is the test length at yield, in millimetres;
- S_e is the required stress, in megapascals;
- t is the thickness of the test length, in millimetres;
- W is the width of the narrow portion of the die, in millimetres.

15.2 Ring test pieces

Calculate the tensile strength TS, expressed in megapascals, using the equation

$$TS = \frac{F_m}{2Wt}$$

Calculate the tensile strength at break TS_b , expressed in megapascals, using the equation

$$TS_b = \frac{F_b}{2Wt}$$

Calculate the elongation at break E_b , expressed as a percentage, using the equation

$$E_b = \frac{100(\pi d + 2L_b - C_i)}{C_i}$$

Calculate the stress at a given elongation, S_e , expressed in megapascals, using the equation

$$S_e = \frac{F_e}{2Wt}$$

The distance, in millimetres, between the pulley centres corresponding to a given elongation L_e , also in millimetres, is calculated using the equation

$$L_e = \frac{C_m E_s}{200} + \frac{C_i - \pi d}{2}$$

Calculate the elongation at a given stress, E_s , expressed as a percentage, using the equation

$$E_s = \frac{100(\pi d + 2L_s - C_i)}{C_m}$$



ISO 37:2005(E)

The value, in newtons, of the force F_e corresponding to the required stress is calculated using the equation

$$F_e = 2S_e W t$$

Calculate the tensile stress at yield S_y , expressed in megapascals, using the equation

$$S_y = \frac{F_y}{2Wt}$$

Calculate the elongation at yield E_y , expressed as a percentage, using the equation

$$E_y = \frac{100(\pi d + 2L_y - C_i)}{C_m}$$

In the equations given above, the symbols used have the following meanings:

- C_i is the initial internal circumference of the ring, in millimetres;
- C_m is the initial mean circumference of the ring, in millimetres;
- d is the diameter of the pulleys, in millimetres;
- E_s is the given elongation, expressed as a percentage;
- F_b is the force recorded at break, in newtons;
- F_e is the required force at the given strain, in newtons;
- F_m is the maximum force recorded, in newtons;
- F_y is the force recorded at yield, in newtons;
- L_b is the distance between pulley centres at break, in millimetres;
- L_s is the distance between pulley centres at the given stress, in millimetres;
- L_y is the distance between pulley centres at yield, in millimetres;
- S_e is the required stress, in megapascals;
- t is the axial thickness of the ring, in millimetres;
- W is the radial width of the ring, in millimetres.

16 Expression of results

When more than one tensile stress-strain property is being determined on the same test pieces, the test data shall be treated as if they had been obtained independently for each property and the result calculated as described for each property separately.

In all cases, the median for each property shall be reported.



17 Test report

The test report shall include the following particulars:

- a) a reference to this International Standard;
- b) details of sample and test pieces:
 - 1) a full description of the sample and its origin,
 - 2) compound details and cure condition, if known,
 - 3) a description of the test pieces:
 - the method of preparation of the test pieces (e.g buffing), the type of test piece, its median thickness,
 - the direction relative to grain in which dumb-bell test pieces were cut,
 - 4) the number of test pieces tested;
- c) test details:
 - 1) the temperature of test, if other than the standard laboratory temperature, and the relative humidity if necessary,
 - 2) the date of testing,
 - 3) any deviations from the procedure specified;
- d) the test results, i.e. the median values of the properties determined, calculated in accordance with Clause 15.



Annex A
(informative)

Preparation of type B ring test pieces

The rings may be cut out using a rotary cutting machine operated at 400 rev/min and fitted with a special holder for blades (see Figure A.1). The blades shall be lubricated with soap solution and inspected frequently for sharpness, damage, etc. The sample shall be secured during cutting with the device shown in Figure A.2.





Dimensions in millimetres

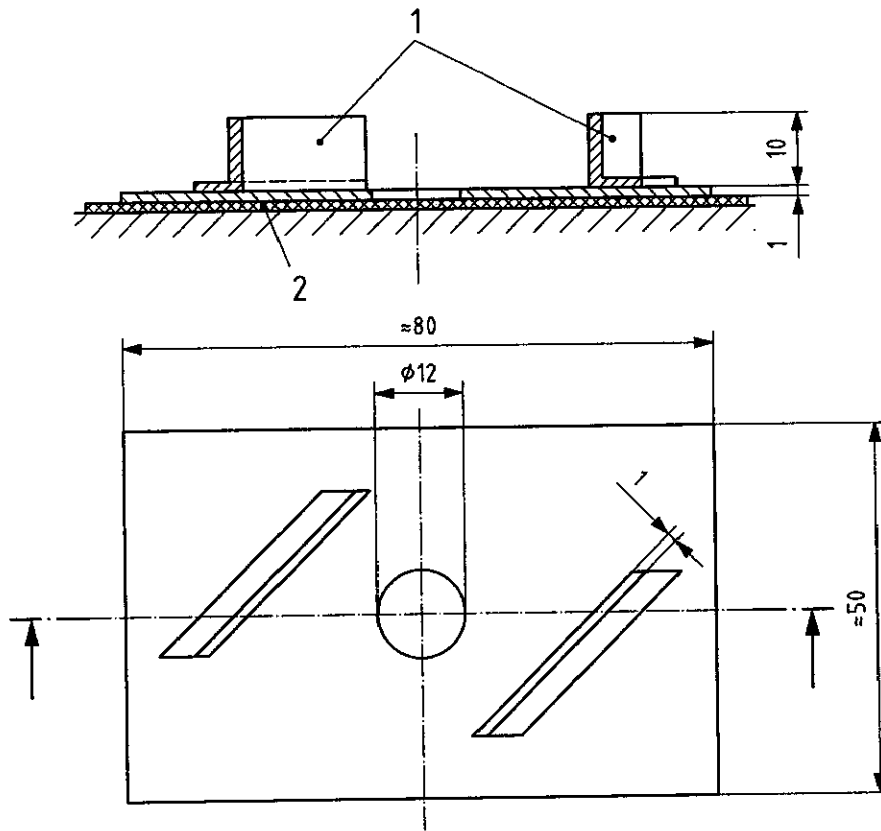

Key

- 1 protection for operator's fingers
- 2 sheet to be cut

Figure A.2 — Tool for holding the rubber sheet



Annex B (informative)

Precision

B.1 General

The repeatability and reproducibility of the method were calculated on the basis of ISO/TR 9272:2005. Original data were treated for outliers at the 5 % and 2 % significance level on the basis of the procedures described in ISO/TR 9272:2005.

B.2 Details of test programmes

B.2.1 Two inter-laboratory test programmes (ITPs) were organized.

The first ITP in 2001 was as follows:

Three different compounds of NR, SBR and EPDM were used for tensile tests. A test result for this test method was the average or mean of five separate measurements of each of the properties as indicated below.

A total of 23 laboratories in eight countries participated in the programme.

The second ITP in 2002 was as follows:

One NR compound was used for tensile testing. The compound formulation was the same as the NR compound used in the first ITP.

A total of 17 laboratories in six countries participated in the programme.

The fully prepared rubber test pieces were sent to each laboratory for evaluation in both ITPs with type 1 precision.

B.2.2 The test properties to be measured were tensile strength at break (TS_b), elongation at break (E_b), stress at 100 % elongation (S_{100}) and stress at 200 % elongation (S_{200}).

B.2.3 Three types of dumb-bell, type 1, type 2 and type 1A, were tested.

The type 1 was tested with two test lengths of 20 mm and 25 mm marked on them in the first ITP, but for the second ITP only test pieces with a test length of 25 mm were tested.

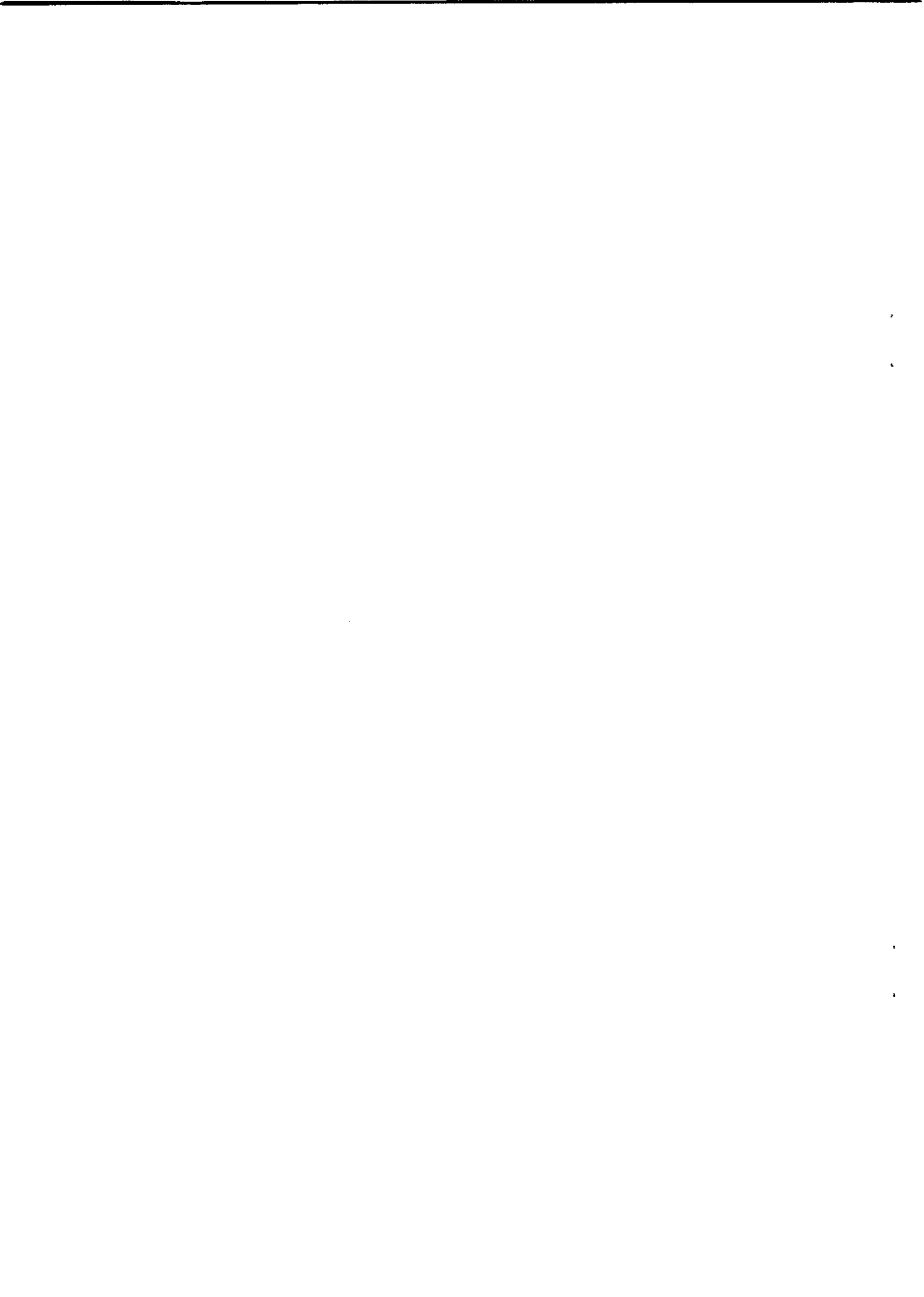

B.3 Precision results

The results calculated for the precision are given in Tables B.1, B.2, B.3 and B.4. Tables B.1, B.2 and B.3 show the results of the first ITP for the NR, SBR and EPDM compounds, respectively. Table B.4 shows the results of the second ITP for NR.

The symbols used in these tables are defined as follows:

- r = repeatability, in measurement units;
- (r) = repeatability, in percent (relative);
- R = reproducibility, in measurement units;
- (R) = reproducibility, in percent (relative).

Table B.1 — Precision for NR compound (first ITP)

Property	Dumb-bell type/ test length	Mean value $N = 23 \times 2 = 46$	Within-laboratory repeatability		Inter-laboratory reproducibility	
			r	(r)	R	(R)
TS_b	Type 1/20 mm	34,25	1,10	3,20	3,35	9,79
	Type 1/25 mm	34,17	1,53	4,47	2,49	7,29
	Type 2/20 mm	31,93	1,25	3,93	2,85	8,94
	Type 1A/20 mm	34,88	0,67	1,91	2,63	7,54
E_b	Type 1/20 mm	671	42,1	6,28	57,2	8,52
	Type 1/25 mm	670	66,3	9,89	63,1	9,41
	Type 2/20 mm	651	29,9	4,60	60,5	9,29
	Type 1A/20 mm	687	29,9	4,35	57,8	8,41
S_{100}	Type 1/20 mm	1,83	0,18	10,00	0,36	19,50
	Type 1/25 mm	1,86	0,12	6,73	0,32	17,24
	Type 2/20 mm	1,84	0,15	8,33	0,40	21,95
	Type 1A/20 mm	1,89	0,07	3,90	0,28	14,81
S_{200}	Type 1/20 mm	4,49	0,45	10,08	0,85	18,97
	Type 1/25 mm	4,42	0,52	11,82	0,77	17,36
	Type 2/20 mm	4,39	0,39	8,79	0,87	19,85
	Type 1A/20 mm	4,58	0,38	8,25	0,70	15,26



Table B.2 — Precision for SBR compound (first ITP)

Property	Dumb-bell type/ test length	Mean value $N = 23 \times 2 = 46$	Within-laboratory repeatability		Inter-laboratory reproducibility	
			r	(r)	R	(R)
TS_b	Type 1/20 mm	24,87	1,48	5,94	2,12	8,53
	Type 1/25 mm	24,60	1,17	4,74	2,58	10,47
	Type 2/20 mm	24,38	1,52	6,22	2,84	11,65
	Type 1A/20 mm	24,70	1,01	4,11	2,38	9,65
E_b	Type 1/20 mm	457	29,3	6,40	39,0	8,53
	Type 1/25 mm	458	31,4	6,85	31,6	6,90
	Type 2/20 mm	462	32,9	7,12	48,2	10,43
	Type 1A/20 mm	459	13,9	3,04	41,1	8,96
S_{100}	Type 1/20 mm	2,64	0,20	7,46	0,51	19,47
	Type 1/25 mm	2,61	0,20	7,52	0,41	15,75
	Type 2/20 mm	2,66	0,24	9,11	0,57	21,30
	Type 1A/20 mm	2,65	0,10	3,87	0,43	16,15
S_{200}	Type 1/20 mm	7,76	0,59	7,62	1,28	16,52
	Type 1/25 mm	7,74	0,47	6,08	0,94	12,15
	Type 2/20 mm	7,68	0,56	7,31	1,48	19,25
	Type 1A/20 mm	7,81	0,45	5,74	1,00	12,79

Table B.3 — Precision for EPDM compound (first ITP)

Property	Dumb-bell type/ test length	Mean value $N = 23 \times 2 = 46$	Within-laboratory repeatability		Inter-laboratory reproducibility	
			r	(r)	R	(R)
TS_b	Type 1/20 mm	14,51	1,13	7,78	2,01	13,83
	Type 1/25 mm	14,59	1,57	10,76	2,22	15,20
	Type 2/20 mm	14,50	1,20	8,26	2,14	14,74
	Type 1A/20 mm	14,77	0,65	4,39	1,87	12,65
E_b	Type 1/20 mm	470	22,2	4,71	32,4	6,90
	Type 1/25 mm	474	33,8	7,13	44,5	9,38
	Type 2/20 mm	475	21,9	4,60	42,4	8,93
	Type 1A/20 mm	471	20,2	4,28	39,2	8,34
S_{100}	Type 1/20 mm	2,33	0,21	8,99	0,36	15,32
	Type 1/25 mm	2,30	0,18	7,61	0,32	13,94
	Type 2/20 mm	2,39	0,17	7,21	0,32	13,52
	Type 1A/20 mm	2,40	0,09	3,87	0,29	12,04
S_{200}	Type 1/20 mm	5,11	0,35	6,87	0,65	12,80
	Type 1/25 mm	5,05	0,25	4,88	0,62	12,35
	Type 2/20 mm	5,08	0,27	5,24	0,71	14,04
	Type 1A/20 mm	5,20	0,22	4,22	0,46	8,84



Table B.4 — Precision for NR compound (second ITP)

Property	Dumb-bell type/ test length	Mean value $N = 17 \times 2 = 34$	Within-laboratory repeatability		Inter-laboratory reproducibility	
			r	(r)	R	(R)
TS_b	Type 1/25 mm	32,26	1,86	5,76	2,21	6,84
	Type 2/20 mm	34,75	1,53	4,41	4,04	11,63
	Type 1A/20 mm	33,13	1,19	3,60	2,71	8,17
E_b	Type 1/25 mm	640	27,26	4,26	54,44	8,50
	Type 2/20 mm	683	30,80	4,51	94,49	13,83
	Type 1A/20 mm	665	22,94	3,45	83,52	12,56
S_{100}	Type 1/25 mm	1,74	0,13	7,29	0,32	18,17
	Type 2/20 mm	1,83	0,20	11,08	0,30	16,18
	Type 1A/20 mm	1,78	0,13	7,06	0,22	12,19
S_{200}	Type 1/25 mm	4,27	0,32	7,42	1,10	25,81
	Type 2/20 mm	4,31	0,44	10,31	1,03	23,91
	Type 1A/20 mm	4,35	0,21	4,78	0,87	20,11



Annex C (informative)

Analysis of ITP data and dumb-bell shape

C.1 General

This annex considers the performance of the different dumb-bell shapes, including the type 1A, that was measured through the ITP programmes. The type 1A dumb-bell is a new addition to this International Standard, but it has been in use in Japan and other countries for many years.

Interlaboratory tests showed that the type 1A dumb-bell has advantages over types 1 and 2 of better repeatability and, particularly, lower incidence of breaks outside the test length. Finite-element analysis demonstrated that the strain distribution in the type 1A is more uniform, which probably accounts for its improved performance.

The values of tensile properties determined with the type 1A dumb-bell are very similar to those obtained with the type 1, but they cannot be expected to be identical in all cases.

The type 1A dumb-bell has similar overall dimensions to the type 1 and can be considered as an alternative. It has not replaced the type 1 because of the huge bank of data obtained and the long tradition with the latter dumb-bell.

C.2 Three variances for three-factor fully-nested experiments

In the comparison of the precision calculated in accordance with ISO/TR 9272:2005, R is an indicator of the variance between laboratories (σ_L^2), and the r is an indicator of the total variance ($\sigma_D^2 + \sigma_M^2$) for a particular laboratory, made up of the variance between the days (σ_D^2) and the variance due to measurement errors (σ_M^2). In order to analyse σ_D^2 and σ_M^2 separately, it is enough to make an estimate of each component of the variance by the so-called three-factor fully-nested experiments described in ISO 5725-3.

The estimate was made for each component of the total variance in the measurements in the second ITP. The results are shown in Tables C.1 and C.2.

Table C.1 — Estimate of each component of the variance by means of “three-factor fully-nested experiments” for tensile strength in the second ITP

	Type 1	Type 2	Type 1A
σ_L^2	$(0,60)^2$	$(1,80)^2$	$(0,80)^2$
σ_D^2	$(0,67)^2$	$(0,54)^2$	$(0,17)^2$
σ_M^2	$(1,60)^2$	$(1,08)^2$	$(1,04)^2$



Table C.2 — Estimate of each component of the variance by means of “three-factor fully-nested experiments” for elongation in the second ITP

	Type 1	Type 2	Type 1A
σ_L^2	(20,4) ²	(43,7) ²	(24,3) ²
σ_D^2	(13,6) ²	(21,9) ²	(28,6) ²
σ_M^2	(28,1) ²	(19,3) ²	(19,3) ²

Of the three variances, the variance due to measurement errors (σ_M^2) is the most important for the dumb-bell shape. Other variances (σ_L^2 and σ_D^2) are influenced by many factors other than the dumb-bell shape.

It is shown that σ_M^2 is smallest for the type 1A dumb-bell, which means that the measurement precision is best with this type.

C.3 Analysis of test pieces that broke

C.3.1 Numbers of test pieces that broke outside the test length

Figure C.1 shows the numbers of test pieces that broke outside the test length (outside the reference marks). For each dumb-bell type, 230 test pieces were tested, as 23 laboratories each tested five test pieces on two test days.

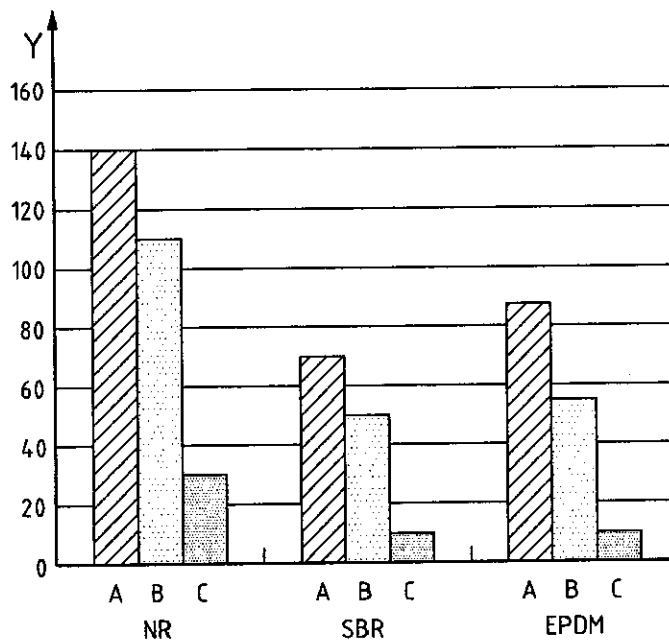

Key

Y number of test pieces that broke outside test length

- A type 1 dumb-bell
- B type 2 dumb-bell
- C type 1A dumb-bell

Figure C.1 — Numbers of test pieces that broke outside the test length (first ITP — total of 230 of each type of test piece)



In the case of the type 1 dumb-bells made of NR compound with a 20 mm test length, 159 test pieces broke outside the test length, which is about 70 %. In the case of type 1 with a 25 mm test length, it was about 60 % of the test pieces. In the case of type 2, it was 47 %. However, in the case of type 1A, only 13 % of the test pieces broke outside the test length.

With SBR and EPDM, the probability of breaking outside the test length for type 1A is also considerably smaller than for the other dumb-bells.

C.3.2 Relationship between the proportion of test pieces that broke outside the test length vs tensile energy

The relationship between the percentage of test pieces that broke outside the test length and the tensile energy (tensile strength multiplied by elongation at break) was also investigated. NR compounds differing in the volume of carbon black they contained were prepared, and their TS_b and E_b measured. The percentage of test pieces that broke outside the test length was observed. Figure C.2 shows the results of this experiment.

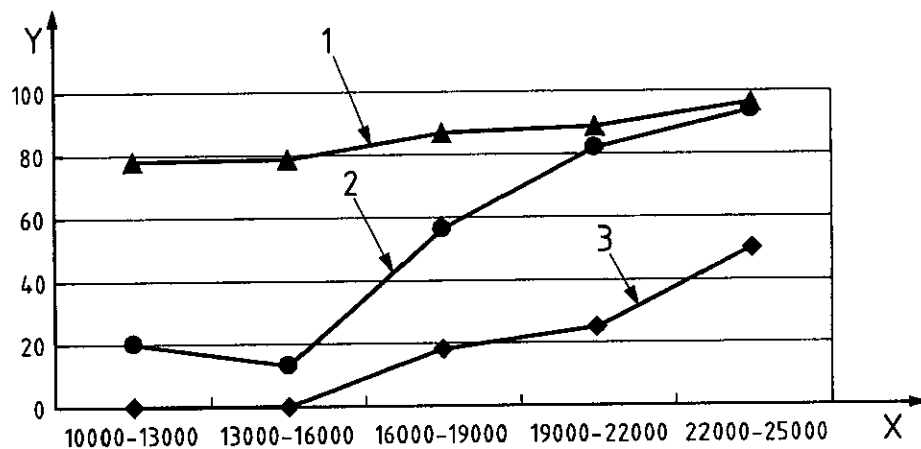

Key

- X $TS_b \times E_b$ (MPa·%)
 Y percentage of test pieces that broke outside test length
- 1 type 1 dumb-bell
 2 type 2 dumb-bell
 3 type 1A dumb-bell

Figure C.2 — Percentage of test pieces that broke outside the test length vs $TS_b \times E_b$ (tensile energy)

As the value of the tensile energy increased, the percentage of test pieces that broke outside the test length increased. At values of the tensile energy below 20 000 MPa, most of the type 1A test pieces broke inside the test length.

C.4 Finite-element analysis

A finite-element analysis (FEA) was conducted on part of the test piece. Figure C.3 shows the distribution of the strain, obtained using "ABAQUS" software.

The analysis of the strain distribution shows that the highest strain area appears near the edge of the pieces for type 1 and type 2. This observation coincides with the results of the tensile testing described in Clause C.3.



On the other hand, for type 1A, the strain near the edge is at the same level as in the central area, which means type 1A has a relatively uniform strain distribution.

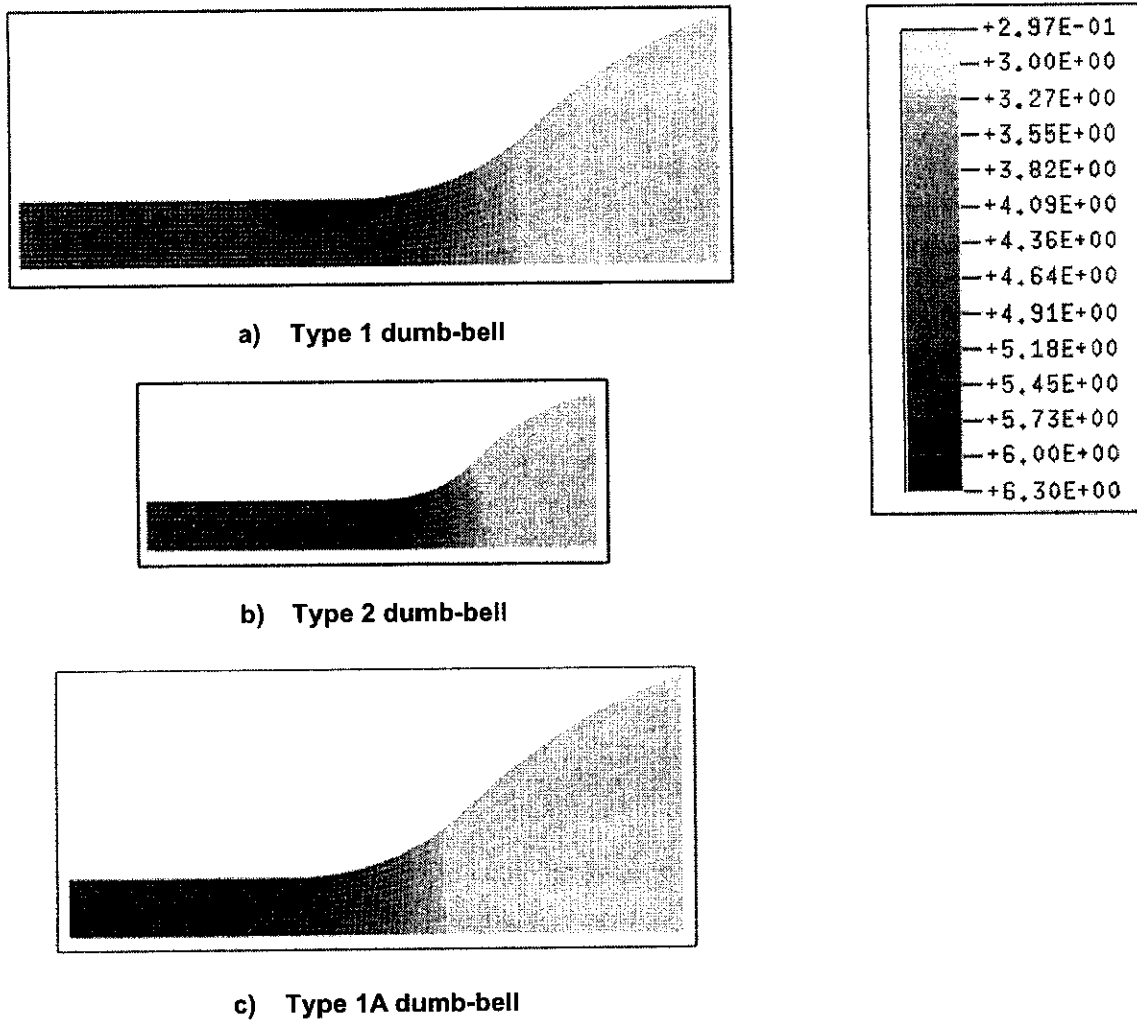
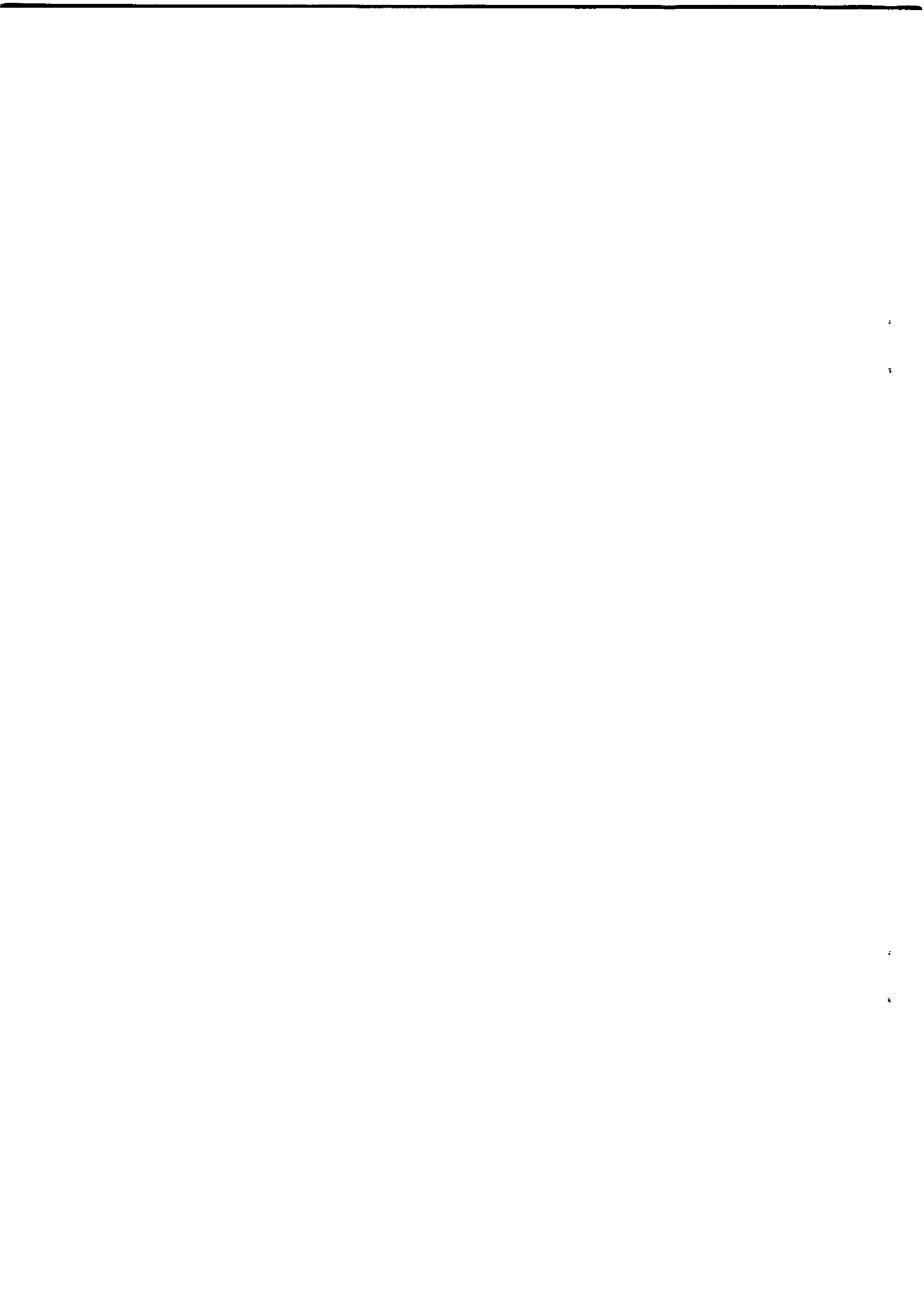

Figure C.3 — Example of strain distribution obtained using "ABAQUS"



Bibliography

- [1] ISO/TR 9272:2005, *Rubber and rubber products — Determination of precision for test method standards*
- [2] ISO 5725-3, *Accuracy (trueness and precision) of measurement methods and results — Part 3: Intermediate measures of the precision of a standard measurement method*

ISO 37:2005(E)

ICS 83.060

Price based on 25 pages

© ISO 2005 – All rights reserved

