

# INTERNATIONAL STANDARD

# ISO 630

Second edition  
1995-11-15

---

---

## **Structural steels — Plates, wide flats, bars, sections and profiles**

*Aciers de construction métallique — Tôles, larges-plats, barres, poutrelles  
et profilés*



Reference number  
ISO 630:1995(E)

**ISO 630:1995(E)****Foreword**

ISO (the International Organization for Standardization) is a worldwide federation of national standards bodies (ISO member bodies). The work of preparing International Standards is normally carried out through ISO technical committees. Each member body interested in a subject for which a technical committee has been established has the right to be represented on that committee. International organizations, governmental and non-governmental, in liaison with ISO, also take part in the work. ISO collaborates closely with the International Electrotechnical Commission (IEC) on all matters of electrotechnical standardization.

Draft International Standards adopted by the technical committees are circulated to the member bodies for voting. Publication as an International Standard requires approval by at least 75 % of the member bodies casting a vote.

International Standard ISO 630 was prepared by Technical Committee ISO/TC 17, *Steel*, Subcommittee SC 3, *Steels for structural purposes*.

This second edition cancels and replaces the first edition (ISO 630:1980), which has been technically revised.

Annexes A and B form an integral part of this International Standard. Annexes C and D are for information only.

© ISO 1995

All rights reserved. Unless otherwise specified, no part of this publication may be reproduced or utilized in any form or by any means, electronic or mechanical, including photocopying and microfilm, without permission in writing from the publisher.

International Organization for Standardization  
Case Postale 56 • CH-1211 Genève 20 • Switzerland

Printed in Switzerland

# Structural steels — Plates, wide flats, bars, sections and profiles

## 1 Scope

This International Standard specifies qualities for the general purpose structural steels listed in table 1.

This International Standard applies to steel plates with thicknesses of 3 mm and over, wide strip in coils with widths greater than or equal to 600 mm, and greater than 6 mm in thickness, wide flats, bars and hot-rolled sections generally used in the as-delivered condition and normally intended for bolted, riveted or welded structures<sup>1)</sup>.

It does not include the following steels, certain of which are covered by other International Standards:

- steels for boilers and pressure vessels (ISO 9328-2);
- plates of drawing quality (ISO 3573 and ISO 3574);
- heat-treated (quenched and tempered) structural steels;
- bars for the reinforcement of concrete;
- strip of width greater than or equal to 600 mm and thickness equal to or less than 6 mm (ISO 4955).

## 2 Normative references

The following standards contain provisions which, through reference in this text, constitute provisions

1) For precautions to be taken when welding, see the guide for the welding and weldability of C-Mn and C-Mn micro-alloy steels published by Sub-commission IX-G of the International Welding Institute (document IIS/IWI 843-87), together with the notes given in annex D.

In particular, in the case of grade E 355, it should be noted that ISO 4950-2 specifies an equivalent grade with better welding characteristics.

of this International Standard. At the time of publication, the editions indicated were valid. All standards are subject to revision, and parties to agreements based on this International Standard are encouraged to investigate the possibility of applying the most recent editions of the standards indicated below. Members of IEC and ISO maintain registers of currently valid International Standards.

ISO 148:1983, *Steel — Charpy impact test (V-notch)*.

ISO 377-1:1989, *Selection and preparation of samples and test pieces of wrought steels — Part 1: Samples and test pieces for mechanical test*.

ISO 377-2:1989, *Selection and preparation of samples and test pieces of wrought steels — Part 2: Samples for the determination of the chemical composition*.

ISO 404:1992, *Steel and steel products — General technical delivery requirements*.

ISO 2566-1:1984, *Steel — Conversion of elongation values — Part 1: Carbon and low alloy steels*.

ISO 3573:1986, *Hot-rolled carbon steel sheet of commercial and drawing qualities*.

ISO 3574:1986, *Cold-reduced carbon steel sheet of commercial and drawing qualities*.

ISO 4948-1:1982, *Steels — Classification — Part 1: Classification of steels into unalloyed and alloy steels based on chemical composition*.

ISO 4950-2:1995, *High yield strength flat steel products — Part 2: Products supplied in the normalized or controlled rolled condition.*

ISO 4955:1994, *Heat-resisting steels and alloys.*

ISO 4995:1993, *Hot-rolled steel sheet of structural quality.*

ISO 6892:1984, *Metallic materials — Tensile testing.*

ISO 6929:1987, *Steel products — Definitions and classification.*

ISO 7788:1985, *Steel — Surface finish of hot-rolled plates and wide flats — Delivery requirements.*

ISO 9328-2:1991, *Steel plates and strips for pressure purposes — Technical delivery conditions — Part 2: Unalloyed and low-alloyed steels with specified room temperature and elevated temperature properties.*

ISO 10474:1991, *Steel and steel products — Inspection documents.*

### 3 Definitions

Definitions of the terms "plate", "wide strip (coils)", "narrow strip" and "wide flat" are given in ISO 6929.

## 4 General requirements

### 4.1 Steelmaking process

Unless otherwise agreed at the time of enquiry and order, the steelmaking process is left to the discretion of the manufacturer; except for quality 0, the purchaser shall be informed of the process at the time of delivery.

### 4.2 Delivery condition

**4.2.1** The products are generally delivered in the as-rolled condition. Other delivery conditions may form the subject of agreement when ordering.

**4.2.2** Flat products of quality D may be ordered in two categories.

— Quality D1: shall be delivered in the normalized or equivalent condition. The mechanical properties given in table 3 are applicable in both the delivered

condition and after normalizing by separate heat treatment after delivery.

— Quality D2: the mechanical properties given in table 3 are only applicable in the delivery condition. The delivery condition is left to the discretion of the manufacturer.

## 4.3 Surface appearance — Defects

### 4.3.1 Surface appearance

The products shall have a smooth surface corresponding to the rolling method used; they shall have no defects that are prejudicial to their subsequent processing or appropriate use.

### 4.3.2 Flat products

The requirements of ISO 7788 shall apply.

### 4.3.3 Long products

**4.3.3.1** Minor defects may be removed by the manufacturer by grinding, provided that the thickness stays within the lower tolerance limits specified in the appropriate International Standards (see list in annex C) or, in the absence of International Standards, is not reduced locally by more than 6 % in relation to its nominal value.

**4.3.3.2** Unless otherwise specified in the order, imperfections that are greater in depth than the limits specified in 4.3.3.1 may be removed and deposited by welding subject to the following conditions.

- a) The reduction of thickness of the material, resulting from removal of imperfections prior to welding, shall not exceed 2 % of the nominal thickness at the location of the imperfection.
- b) All welding shall be performed by competent welders, using welding electrodes appropriate for the grade being repaired and following welding procedures approved by the purchaser.

## 5 Characteristics of grades and qualities

### 5.1 Chemical composition

The steels specified are unalloyed steels in accordance with ISO 4948-1.

### 5.1.1 Ladle analysis

The composition limits for ladle analysis are given in table 1 and are maximum values.

### 5.1.2 Product analysis

Table 2 gives the permitted deviations on analysis relative to the values for ladle analysis which are given in table 1.

### 5.2 Mechanical properties

The steels, in the delivery condition defined in 4.2, shall comply with the mechanical properties specified in table 3 when these are determined on test pieces selected in accordance with 6.4.

For products over 200 mm in thickness, the mechanical properties shall be the subject of an agreement between the interested parties.

**Table 1 — Chemical composition (ladle analysis)**

Grade	Quality	Thickness <i>e</i> mm	Method of deoxi- dation <sup>1)</sup>	C % max.	P % max.	S % max.	Mn % max.	Si % max.
E 185 (Fe 310)	0							
E 235 (Fe 360)	A	$e \leq 16$ $16 < e \leq 25$ $e \leq 40$ $e > 40$	—	0,22	0,050	0,050	—	—
	B		—	0,17	0,045	0,045	1,40	0,40
			—	0,20	0,045	0,045	1,40	0,40
			NE	0,17	0,045	0,045	1,40	0,40
			NE	0,20	0,045	0,045	1,40	0,40
	C		NE	0,17	0,040	0,040	1,40	0,40
	D		GF	0,17	0,035	0,035	1,40	0,40
E 275 (Fe 430)	A	$e \leq 40$ $e > 40$	—	0,24	0,050	0,050	—	—
	B		NE	0,21	0,045	0,045	1,50	0,40
			NE	0,22	0,045	0,045	1,50	0,40
			NE	0,20	0,040	0,040	1,50	0,40
	C		NE	0,20	0,040	0,040	1,50	0,40
	D		GF	0,20	0,035	0,035	1,50	0,40
E 355 (Fe 510)	C	$e \leq 30$ $e > 30$ $e \leq 30$ $e > 30$	NE	0,20	0,040	0,040	1,60	0,55
			NE	0,22	0,040	0,040	1,60	0,55
			GF	0,20	0,035	0,035	1,60	0,55
			GF	0,22	0,035	0,035	1,60	0,55

1) NE = Non-rimming.  
GF = These steels shall have a sufficiently high content of elements to produce a fine-grained structure, for example total Al  $\geq$  0,02 %.

**Table 2 — Permissible deviation for the product analysis relative to the specified ladle analysis (see 6.4.3.1)**

Element	Specified limits %	Permissible deviation
C	$\leq 0,24$	+ 0,03
P	$\leq 0,050$	+ 0,010
S	$\leq 0,050$	+ 0,010
Mn	$\leq 1,60$	+ 0,10
Si	$\leq 0,55$	+ 0,05

**Table 3 — Mechanical properties**

Grade	Quality	$R_{eH}$ min. N/mm <sup>2</sup>						$R_m$ <sup>1)</sup> N/mm <sup>2</sup>	A min. $(L_0 = 5,65\sqrt{S_0})$ %					Impact test (V-notch), KV		
		10 A B	15 A B	20 A B	25 A B	30 A B	35 A B		40 A B	45 A B	50 A B	55 A B	60 A B	Test temperature °C	Energy <sup>3)</sup> min. J	
E 185 <sup>4)</sup> (Fe 310)		185	175	—	—	—	—	300-540	18	—	—	—	—	—	—	—
E 235 (Fe 360)	A	235	225	215	215	215	185	340-470	26	25	24	22	21	—	—	—
	B <sup>4)</sup>	235	225	—	—	—	—	340-470	26	—	—	—	—	—	—	—
	B NF	235	225	215	215	195	185	340-470	26	25	24	22	21	+20	27	—
	C	235	225	215	215	195	185	340-470	26	25	24	22	21	0	27	—
E 275 (Fe 430)	D	235	225	215	215	195	185	340-470 <sup>5)</sup>	26	25	24	22	21	-20	27	—
	A	275	265	255	245	235	215	410-540	22	21	20	18	17	—	—	—
	B	275	265	255	245	235	215	410-540	22	21	20	18	17	+20	27	—
	C	275	265	255	245	235	215	410-540	22	21	20	18	17	0	27	—
E 355 (Fe 510)	D	275	265	255	245	235	215	410-540 <sup>5)</sup>	22	21	20	18	17	-20	27	—
	C	355	345	335	325	315	285	490-640	22	21	20	18	17	0	27	—

$R_{eH}$  = upper yield stress  
 $R_m$  = tensile strength  
A = percentage elongation after fracture  
 $L_0$  = gauge length on test piece  
 $S_0$  = original cross-sectional area of gauge length  
e = thickness of steel product, in millimetres  
1 N/mm<sup>2</sup> = 1 MPa

- 1) For the tensile strength of wide strip (coils), only the minimum value of the range is applicable.
- 2) For transverse test pieces (plates and wide flats of width 600 mm and over), these values are reduced by two points.
- 3) Average of three tests; no individual result shall be less than 70 % of the specified minimum average value.
- 4) This quality is only delivered in thicknesses less than 25 mm.
- 5) For thicknesses over 100 mm, a tolerance of 20 N/mm<sup>2</sup> on the lower value of the range is permitted.

## 6 Inspection and testing

### 6.1 General

Rolled products covered by this International Standard may be the subject of an inspection and testing in accordance with the conditions specified in 8.3 of ISO 404:1992, relating to the mechanical properties and chemical analysis of the product. However, grade E 185 is only supplied with non-specific inspection and testing. Verification of chemical composition on the product and of the impact energy values at ambient temperature is only carried out by agreement at the time of enquiry and order.

If an inspection and testing has been specified in the order, it shall be carried out in accordance with 6.2 to 6.5, unless otherwise agreed when ordering.

### 6.2 Test unit

Batching shall be by cast.

**6.2.1** The test unit shall be 50 t or part thereof taken from one cast.

**6.2.2** For each test unit and thickness range, as defined in table 3, the series of tests shall be carried out comprising

— one tensile test (or more, in accordance with 6.2.4.1 in the case of products of thickness up to and including 16 mm);

— one set of three impact tests at 0 °C for quality C and one set of three tests at – 20 °C for quality D;

and, if specified on the order,

— one product analysis;

— one set of three impact tests at + 20 °C for quality B.

**6.2.3** The purchaser or his representative may witness the selection of the product sample from which the samples shall be taken for the verification of properties (see ISO 404).

**6.2.4** Unless otherwise agreed by the purchaser, the procedure shall be as follows.

#### 6.2.4.1 Tensile test

A test sample shall be taken for each thickness range given in table 3, with a supplementary requirement

that, for the range  $e \leq 16$  mm, the thickness of products shall be such that the maximum thickness is not greater than twice the minimum thickness.

#### 6.2.4.2 Impact test

A test sample shall be taken for each thickness range given in table 3.

For flat products of quality D, if agreed at the time of enquiry and order, a test sample shall be taken from each rolled product (parent plate or coil).

### 6.3 Position and orientation of test samples (see ISO 377-1 and ISO 377-2)

#### 6.3.1 Plates, wide strip (coils) and wide flats of width equal to or greater than 600 mm

The test samples shall be taken midway between the centreline in the direction of rolling and the edge of the rolled product.

**6.3.1.1** The longitudinal axes of tensile test pieces shall be perpendicular to the direction of rolling.

**6.3.1.2** The longitudinal axes of impact test pieces shall always be parallel to the direction of rolling.

#### 6.3.2 Sections, girders and wide flats of width less than 600 mm

The longitudinal axes of the test pieces shall be parallel to the direction of rolling. However, if agreed, a transverse test piece may be used for widths between 450 mm and 600 mm.

For sections, the test samples shall be taken such that the axis of the test piece is 1/3 from the outer edge of the half-flange (for I, H and U sections, see ISO 6929) or of the flange (for other sections) or, in the case of small sections, as near as possible to this position (see figure A.1). In the case of tapered-flange sections, the test samples may be taken at the outer 1/4 position of the web.

#### 6.3.3 Rounds, squares, flat bars, hexagons and other similar products

The longitudinal axes of test pieces shall be parallel to the direction of rolling.

For small sizes, the test piece shall consist of a length of the product.

In other cases, the test samples shall be taken so that the axis of the test piece, so far as possible, is located:

- for squares and flat bars, at 1/3 of the half-width (from the outer face) or of the half-diagonal;
- for rounds and hexagons, at 1/3 from the outside of the half-diagonal or the half-diameter (see figure A.1).

## 6.4 Test methods — Types of test pieces

### 6.4.1 Tensile test (see ISO 6892)

Normally the test piece used shall have a proportional prismatic or cylindrical shape and have an original gauge length ( $L_0$ ) given by the formula

$$L_0 = 5,65\sqrt{S_0}$$

where  $S_0$  is the original cross-sectional area of the gauge length.

The prismatic test piece of rectangular cross-section shall have a maximum width on the gauge length portion of 40 mm, and its thickness shall be that of the product; however, if the product thickness exceeds 30 mm, it may be reduced to 30 mm by planing or milling on one face only.

A cylindrical test piece may be used for products of thickness greater than 40 mm; it shall be 10 mm to 30 mm in diameter and its original gauge length shall be determined by the formula given above; the axis of the test piece shall be positioned at 1/4 of the thickness of the product.

A non-proportional test piece with a fixed initial gauge length may be used. In this case, reference shall be made to a conversion table (see ISO 2566-1). However, in case of dispute, only the results obtained on a proportional test piece shall be taken into consideration.

The yield stress specified in table 3 is the upper yield stress  $R_{eH}$ . If the yield phenomenon is not visible, either the 0,2 % proof stress ( $R_{p0,2}$ ) or the 0,5 % proof stress (total extension) ( $R_{p0,5}$ ) may be used. The specification of the material is complied with in this respect if one or other of the values corresponds to the specified values of yield stress.

### 6.4.2 Impact test

**6.4.2.1** The impact test shall normally be carried out on products having a thickness greater than or equal to 12 mm or a diameter greater than or equal to 16 mm. The test piece shall be machined so that, for flat products, the face nearest to the rolled surface is not more than 1 mm from it. For products of thickness greater than 40 mm, the test piece shall be taken in such a way that its axis is positioned at 1/4 thickness from the surface.

The notch shall be perpendicular to the rolled surface.

If agreed at the time of enquiry and order, impact tests may be carried out on products of thickness less than 12 mm; the dimensions of the test pieces shall be in accordance with the requirements of ISO 148, i.e. 10 mm × 7,5 mm and 10 mm × 5 mm, or shall correspond to 10 mm ×  $e$ , where  $e$  is the product thickness.

The specified energy values are given in annex B.

**6.4.2.2** The test shall be carried out using a V-notch test piece supported at both ends (see ISO 148), the value to be taken into account being the average of the results obtained on three test pieces cut adjacent to each other from the same product, unless there are reasons for a retest (see 6.4.5).

### 6.4.3 Chemical analysis

**6.4.3.1** If a product analysis is specified on the order, the number of samples to be taken shall be agreed between the parties concerned.

The samples may be taken from the test pieces used to check the mechanical properties or from the full thickness of the product at the same place as the test pieces. In case of dispute, only the analysis of material from the full thickness of the product shall be taken into consideration.

For the selection and preparation of samples for chemical analysis, the requirements of ISO 377-2 shall be applied.

**6.4.3.2** In case of dispute, the method used for chemical analysis shall be in accordance with the requirements specified in the corresponding International Standard. If an International Standard does not exist, the method to be used shall be agreed between the parties concerned.

#### 6.4.4 Faulty tests and defective test pieces

When a test does not give the required results because of an error in carrying out the test, it shall be cancelled. Error in carrying out the test means incorrect machining, incorrect mounting in the testing machine, malfunction of this machine or any other anomaly independent of the metal itself.

If a defective test piece gives satisfactory results, the batch shall be accepted but the corresponding item (from which the test sample was taken) may be subjected to an individual examination for soundness.

#### 6.4.5 Retests

If during inspection, a test does not give the required results, additional tests, unless otherwise agreed, may be carried out as follows.

##### 6.4.5.1 Tensile test

Procedures defined in 8.3.4.3.2 "Non-sequential tests" of ISO 404:1992 shall apply.

##### 6.4.5.2 Impact test

The assessment of impact test results shall be made following a sequential method as described in 8.3.4.2 of ISO 404:1992 and if retests are necessary, they shall be carried out according to 8.3.4.3.3 of ISO 404.

### 6.5 Inspection documents

The type of inspection documents required shall be chosen among those defined in ISO 10474 and specified in the order.

In any case, this inspection document shall state the manufacturer's results for the cast analysis of all chemical elements specified for the steel grade concerned.

### 7 Sorting and reprocessing

The requirements of clause 9 of ISO 404:1992 shall apply.

### 8 Non-destructive tests

If the purchaser requires non-destructive tests to check the soundness of the products by means of ultrasonic, magnetic or dye penetrant methods, these tests shall be agreed upon at the time of enquiry and order. This agreement shall include details of the test methods and interpretation of results.

### 9 Marking

Unless otherwise agreed at the time of ordering, products other than those of E 185 shall be legibly marked to show

- a) the identification symbols for the grade and quality of the steel;
- b) brand of the manufacturer;
- c) where necessary, symbols, letters or numbers which allow the inspection document, test samples and products to be identified.

In the case of products of small unit mass which are consigned in bundles, the above information may be marked on a tag securely attached to each bundle (or it may be marked on the upper plate).

### 10 Order

The order shall specify

- if a particular steelmaking process is required (4.1);
- if the purchaser wishes to be informed of the steelmaking process (the choice of process being left to the manufacturer) (4.1);
- if a particular delivery condition is required (4.2);
- the type of quality D required (4.2.2);
- if repair by welding is not permitted (4.3.3.2);
- if product analysis is required (5.1.2) and the number of samples required (6.4.3.1);
- if impact tests for quality B are required (6.1);
- if impact tests for each rolled product are required for quality D (6.2.4.2);
- if impact tests for products less than 12 mm thick are required (6.4.2.1);
- if retests are not permitted (6.4.5);
- the type of inspection document required (6.5);
- if non-destructive tests are required (clause 8);
- if other types of marking are required (clause 9).

Points that are not specified shall not be taken into account by the manufacturer.

**Annex A**  
(normative)

**Position and orientation of test pieces**

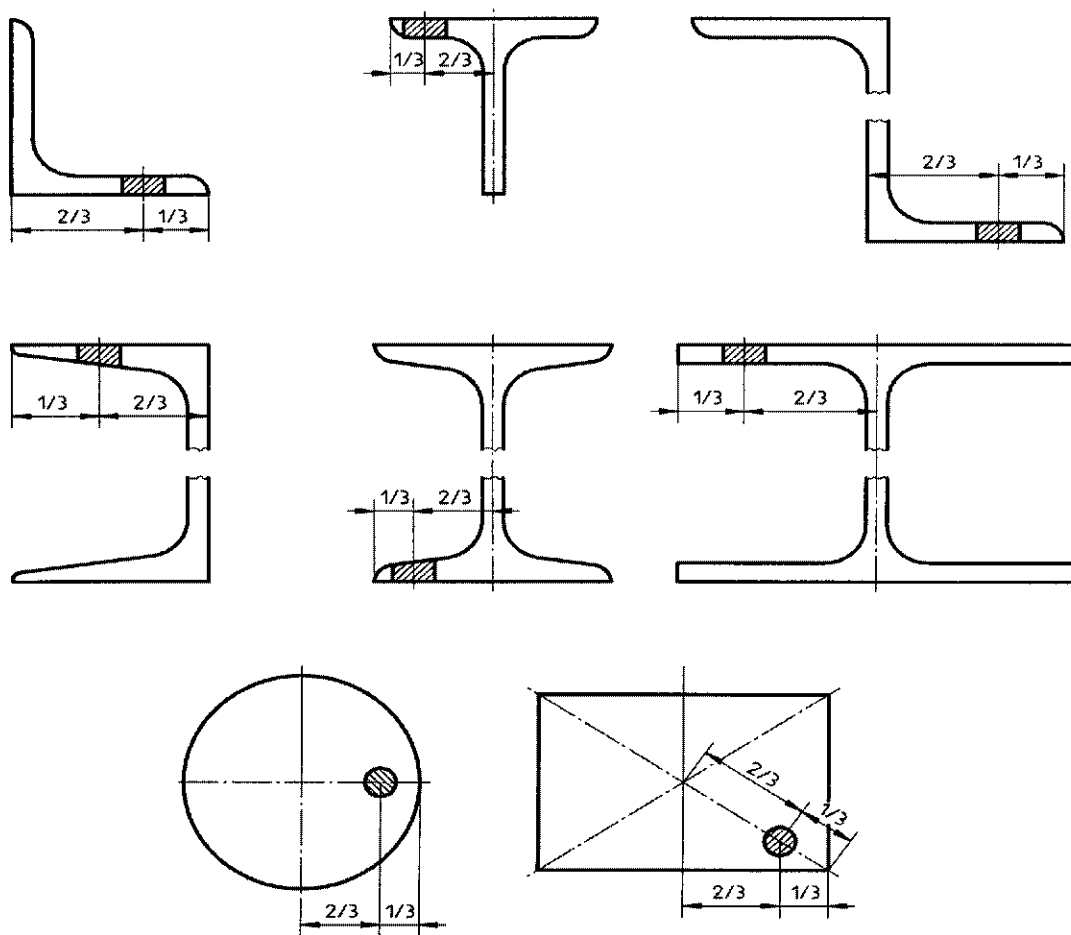

 Position of test pieces

NOTE — See 6.4.2 (for the impact test, see also 6.4.2.1).

**Figure A.1 — Position and orientation of test pieces**

**Annex B**  
(normative)

**Energy values for impact test pieces of reduced size**

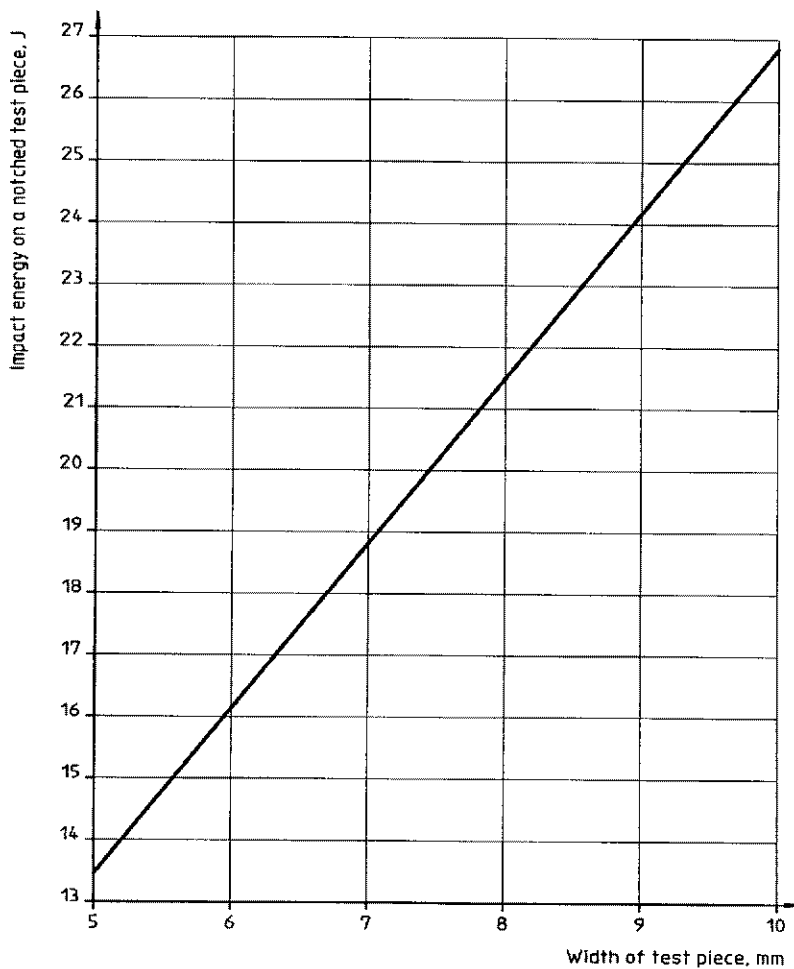

**Figure B.1 — Minimum impact energy values for test pieces with a width between 5 mm and 10 mm**

## Annex C

(informative)

### List of International Standards on tolerances for steel products

ISO 657-5:1976, *Hot-rolled steel sections — Part 5: Equal-leg angles and unequal-leg angles — Tolerances for metric and inch series*

ISO 657-13:1981, *Hot-rolled steel sections — Part 13: Tolerances on sloping flange beam, column and channel sections*

ISO 657-18:1980, *Hot-rolled steel sections — Part 18: L sections for shipbuilding (metric series) — Dimensions, sectional properties and tolerances*

ISO 657-19:1980, *Hot-rolled steel sections — Part 19: Bulb flats (metric series) — Dimensions, sectional properties and tolerances*

ISO 1035-4:1982, *Hot-rolled steel bars — Part 4: Tolerances*

ISO 7452:1984, *Hot-rolled structural steel plates — Tolerances on dimensions and shape*

## Annex D (informative)

### Notes on weldability

The steels specified in this International Standard do not have unlimited suitability for the various welding processes, since the behaviour of a steel during and after welding depends not only on the material but also on the dimensions and shape, as well as on the manufacture and service conditions of the components.

There is no information concerning the weldability of the grade E 185 and quality A available, as no requirements are specified concerning the chemical composition or in a satisfactory way in terms of weldability.

Steels of qualities B, C and D are generally suitable for all welding processes.

The weldability increases from quality B to D.

For grade E 235 B, killed steels (NE or GF) are preferable to steels without specified deoxidation, particularly if segregation zones could be encountered during welding.

With increasing product thickness and increasing strength level, the main risk is the occurrence of cold cracking in the welded zone.

Cold cracking is caused by a combination of the following factors:

- the amount of diffusible hydrogen in the weld metal;
- a brittle structure of the heat-affected zone;
- a significant concentration of tensile stress in the welded joint.

---

---

**ICS 77.140.50; 77.140.60; 77.140.70**

**Descriptors:** iron and steel products, structural steels, metal plates, metal bars, metal sections, wide strips, wide flats, specifications, mechanical properties, chemical composition, grades (quality), tests, acceptance testing, chemical analysis, marking, delivery condition.

Price based on 11 pages

---

---