

Norme
Internationale
International
Standard

**CEI
IEC
60896-2-1**

Deuxieme édition
Second edition
2002 (?)

**Batteries stationnaires au plomb-
Partie 2: Batteries étanches à soupapes**

Section 1: Caractéristiques fonctionelles et méthodes d'essais-

**Stationary Lead-Acid Batteries
Part 2: Valve Regulated Types**

Section 1: Functional characteristics and methods of test

**IEC TC21 WG3 Committee draft (CD)
February 2001
based on
WG3 sessions London & Phoenix 2000 and Nice 2001**

File: IEC60896-2.1CDFINAL.doc



Commission Electrotechnique Internationale
International Electrotechnical Commission
Международная Электротехническая Комиссия

60896-2-1 © IEC:2002(?)

International Electrotechnical Commission

Stationary Lead-Acid Batteries

Part 2: Valve regulated types

Section 1: Functional characteristics and methods of test

Foreword

- 1) The IEC (International Electrotechnical Commission) is a worldwide organization comprising for standardization comprising all national electrotechnical committees (IEC National Committees). The object of the IEC is to promote international cooperation on all questions concerning standardization in the electrical and electronic fields. To this end and in addition to other activities, the IEC publishes International Standards. Their preparation is entrusted to technical committees; any IEC National Committee interested in the subject dealt with may participate in this preparatory work. International, governmental and non governmental liaising with the IEC also participate in this preparation. The IEC collaborates closely with the International Organization of Standardization (ISO) in accordance with conditions determined by agreements between the two organizations.
- 2) The formal decisions or agreements of the IEC on technical matters, prepared by technical committees on which all the National Committees having a special interest therein are represented, express as nearly as possible, an international consensus of opinion on the subjects dealt with
- 3) They have the form or recommendations for international use published in the form of standards, technical reports or guides and they are accepted by the National Committees in that sense.
- 4) In order to promote international unification, IEC National Committees undertake to apply IEC International Standards transparently to the maximum extent possible in their national and regional standards. Any divergence between the IEC Standards and the corresponding national or regional standard shall be clearly indicated in the later.
- 5) The IEC provides no marking procedure to indicate its approval and cannot be rendered responsible for any equipment declared to be in conformity with one of its standards.

International Standard IEC 60896-2 has been prepared by the IEC technical committee 21: Secondary cells and batteries

The text of this standard is based on the following documents:

| | |
|-----|------------------|
| DIS | Report on voting |
| | |

Full information on the voting for the approval of this standards can be found in the report on the voting indicated in the above table

Acknowledgements

This committee draft of the revised standard 60896-2.1 was elaborated, after two preparatory sessions, in three working group sessions under the convenorship of Mr. Giess, Oerlikon Stationary Batteries Switzerland and with the generous contribution and support of the following WG3 members and ad-hoc experts:

| | | | |
|------------------|------------------------|----------------|---------------------------|
| Mr. Alzieu | EDF, France | Mr. McMEnamin | Bell Atlantic, USA |
| Mr. Brandenstein | Gertek, Germany | Mr. Mihal | Alcatel, Germany |
| Mr. Chalsani | Lucent, USA | Mr. Misra | C&D, USA |
| Mr. Clerici | CGA, Italy | Mr. Muneret | Hawker, France |
| Mr. Croda | Sprint, USA | Mr. Nagai | Yuasa, Japan |
| Mr. Deshpandè | GNB, USA | Mr. Pang | Nokia, England |
| Mr. Dupendant | France Telecom, France | Mr. Raybaut | MGE, France |
| Mr. Feder | Consultant, USA | Mr. Ruhlmann | C&D, USA |
| Mr. Fischer | GNB, Belgium | Mr. Rusch | BAE, Germany |
| Mr. Hawkins | Telepower, Australia | Mr. Schädlich | Hoppecke, Germany |
| Mr. Hoffmann | Mannesmann, Germany | Mr. Schulz | Deutsche Telekom, Germany |
| Mr. Karlsson | Emerson, Sweden | Mr. Singy | Swisscom, Switzerland |
| Mr. Kniveton | British Telecom; UK | Mr. Sinz | Exide, Germany |
| Mr. Kramm | Exide, Germany | Mr. Sulzer | Siemens, Germany |
| Mr. Laman | Yuasa, USA | Mr. Svensson | Tudor; Sweden |
| Mr. Lailier | Exide, France | Mr. Szymborski | GNB, USA |
| Mr. Lodi | Fiamm, Italy | Mr. Willmes | Hawker, Germany |
| Mr. Lynch | Yuasa, UK | | |
| Mr. Marquet | France Telecom, France | | |
| Mr. May | Fiamm, UK | | |
| Mr. McDowall | Saft, USA | | |
| Mr. McCluer | Lucent, USA | | |

Mr Harrison, Hawker, UK as Chairman of IEC TC21 together with Mr. Boudou, Franbat, France as Secretary of TC21 provided valuable input for the proper organizational approach of this work.

60896-2-1 © IEC:2002(?)

Stationary Lead-Acid Batteries-

Part 2 Valve regulated types

Section 1 Functional characteristics and methods of test

1 General

1.1 Scope and objective

This part of IEC 60896 applies to all stationary lead-acid cells and monoblocs of the valve regulated type for float charge applications, (i.e. permanently connected to a load and to a D.C. power supply), in a static location (i.e. not generally intended to be moved from place to place) and incorporated into stationary equipment or installed in battery rooms for use in telecom, uninterruptible power supply, utility switching, emergency power or similar applications.

The objective of this part of IEC 60896 is to specify the functional characteristics and methods of test for all types of valve regulated stationary lead acid cells and monoblocs used in standby power applications.

This part of IEC 60896 does not apply to lead-acid cells and batteries used for vehicle engine starting applications (IEC 60095 series), solar photovoltaic applications (IEC 61427 series), or general purpose applications (IEC 61056 series).

1.2 Normative references

The following normative documents contain provisions, which referenced in this text, constitute provisions of this part of IEC 60896. At the time of publication, the editions indicated are valid. All normative documents are subject to revision, and parties to agreements based on this part of IEC 60896 are encouraged to investigate the possibility of applying the most recent editions of the normative documents indicated below. Members of IEC and ISO maintain a register of currently valid International Standards.

IEC 50(151): 1978, International Electro technical Vocabulary (IEV) – Multilingual Dictionary on Electricity 1992

IEC 359, 1987, Expression of performance of electrical and electronic measuring equipment

IEC 60707: 1999, Flammability of solid non-metallic materials when exposed to flame sources – List of test methods.

IEC 60695-10-10: 1999, Fire hazard testing Part 11-10 Test flames 50W horizontal and vertical flame test methods

IEC 68-2-32: 1975 Basic environmental testing procedures Part 2: Test; Test Ed: Free fall and Amendment 1 and 2: 1990

ISO 1043-1: 1997 Plastics – Symbols and abbreviated terms; Part 1: Basic polymers and their special characteristics.

1.3 Definitions

For the purpose of this part of IEC 60896, the following definitions apply:

1.3.1 **battery**: Two or more secondary cells connected together and used as a source of electrical energy. [IEV 486]

1.3.2 **battery, monobloc**: A secondary battery in which the plate packs are fitted in a multi-compartment container. [IEV 486]

1.3.3 **battery, floating**: A battery whose terminals are permanently connected to a source of constant voltage sufficient to maintain the battery approximately fully charged, intended to supply a circuit, if the normal supply is temporarily interrupted. [IEV 486]

1.3.4 **battery, capacity**: The quantity of electricity or electrical charge, which a fully charged battery can deliver under specified conditions. The SI unit for electric charge is the coulomb (1C = 1A.s) but in practice, battery capacity is expressed in ampere hours. [IEV 486]

1.3.5 **cell**: An assembly of electrodes and electrolyte, which constitutes the basic unit of a secondary battery. [IEV 486]

1.3.6 **cell, valve regulated**: A secondary cell which is closed under normal conditions but which has an arrangement, which allows the escape of gas if the internal pressure exceeds a predetermined value. The cell cannot normally receive the addition of electrolyte. [IEV 486]

1.3.7 **capacity, actual C_a** : The quantity of electricity a cell or battery delivered when determined experimentally with a discharge at a specified rate to a specified end-voltage and at a specified temperature. This value is usually expressed in ampere hours (Ah).

1.3.8 **capacity, nominal C_n** : A suitable approximate quantity of electricity used to identify the capacity of a cell or battery. This value is usually expressed in ampere hours (Ah). [IEV 486]

1.3.9 **capacity, rated C_r** : The quantity of electricity, declared by the manufacturer which a cell or battery can deliver under specified conditions after a full charge. This value is usually expressed in ampere hours. [IEV 486]

1.3.10 **durability**: The ability of a battery to perform a required function under given conditions of use and maintenance, until a limiting state is reached. Note: A limiting state of a battery may be characterized by the end of the useful life, unsuitability for any economic or technological reasons or other relevant factors. [IEV 191]

1.3.11 **equipment, stationary**: Either fixed equipment or equipment not provided with a carrying handle and having such a mass that it cannot easily be moved. Note. The value of this mass is 18Kg in IEC standards relating to household equipment. [IEV 826]

1.3.12 **product range**: The range of products, i.e. cells or monoblocs, over which specified design features, materials, manufacturing processes, ISO quality systems and manufacturing locations are identical.

1.3.13 **test, accelerated**: Test in which the applied stress level is chosen to exceed that stated in the reference conditions in order to shorten the time duration required to observe the stress response of the item, or to magnify the response in a given time duration. Note: To be valid, an accelerated test shall not alter the basic fault modes and failure mechanisms, or their relative prevalence. [IEV 191]

1.3.14 **test, acceptance**: Contractual test to prove to the customer that the device meets certain conditions of its specification. [IEV 151]

1.3.15 **test, commissioning**: Tests applied on a device carried out on site to prove the correctness of installation and operation. [IEV 151]

1.3.16 **test, endurance**: Test carried out over a time interval to investigate how properties of an item are affected by the application of stated stresses and by their time duration or repeated application. [IEV 151]

1.3.17 **test, type:** A test of one or more devices made to a certain design to show that the design meets certain specifications. [IEV 151]

1.3.18 **thermal runaway:** A critical condition arising during constant voltage charge in which the current and the temperature of the battery produce a cumulative mutually reinforcing effect which further increases them and can lead to the destruction of the battery. [IEV 486]

1.3.19 **voltage, float:** The voltage specified by the manufacturer for a floating battery.

1.3.20 **voltage, boost:** The voltage specified by the manufacturer for an accelerated charge or a mild overcharge of a battery.

2 Functional characteristics

2.1 Functional characteristics

In this part of IEC 60896 the following characteristics are deemed essential to comprehensively define the ability of Stationary Lead-Acid Batteries of the Valve Regulated Type to perform their intended function as a reliable source of emergency power.

These characteristics can be grouped into Safety, Performance and Durability.

2.2 Safety characteristics

These measures describe essential safety characteristics of Stationary Lead-Acid Batteries of the Valve Regulated Type.

| Test Clause | Measures | Purpose |
|-------------|--|---|
| 4.1 | Gas emission intensity | To determine the emitted hydrogen volumes |
| 4.2 | High current tolerance | To indicate the adequacy of current conduction cross-sections |
| 4.3 | Short circuit current and internal resistance | To furnish data for the sizing of fuses in the exterior circuit |
| 4.4 | Protection against short circuit at terminals during transport | To evaluate the adequacy of protective features |
| 4.5 | Protection against internal ignition from external spark sources | To evaluate the adequacy of protective features |
| 4.6 | Protection against ground short propensity | To evaluate the adequacy of design features of the selected battery |
| 4.7 | Presence and durability of required markings | To evaluate the quality of safety information markings |
| 4.8 | Material identification | To ensure the presence of material identification markings |
| 4.9 | Valve operation | To ensure the correct opening of safety valves |
| 4.10 | Flammability rating of materials | To verify the fire hazard class of battery materials |
| 4.11 | Intercell connector performance | To verify the safety margin based on maximum surface temperatures during high rate discharges |

2.3 Performance characteristics

These measures describe essential performance characteristics of Stationary Lead-Acid Batteries of the Valve Regulated Type.

| Test Clause | Measure | Purpose |
|-------------|--|--|
| 4.12 | Discharge capacity | To verify the available capacities at selected discharge rates or discharge durations. |
| 4.13 | Charge retention during storage | To plan storage durations |
| 4.14 | Float service with frequent discharges | To plan charging schedules and modes when frequent power outages are encountered |
| 4.15 | Recharge behavior | To evaluate the battery's power back-up availability after a power outage |

2.4 Durability characteristics

These measures describe essential durability characteristics of Stationary Lead-Acid Batteries of the Valve Regulated Type.

| Test Clause | Measure | Purpose |
|-------------|---|---|
| 4.16 | Float service capability at an operating temperature of 40 °C | To determine the anticipated operational life at elevated temperatures |
| 4.17 | Float service capability at a stress temperature of 55 °C or 60 °C | To determine the anticipated operational life under abnormal operating conditions |
| 4.18 | Overcharge endurance | To determine the anticipated operational life commensurate with poor charge voltage control. |
| 4.19 | Abusive over-discharge | To determine the expected behavior of the battery when excessive capacity withdrawals are encountered |
| 4.20 | Thermal runaway sensitivity | To determine the expected times it takes to establish a condition of escalating current and temperature |
| 4.21 | Low temperature sensitivity | To determine the sensitivity of the battery toward damages induced by electrolyte freezing |
| 4.22 | Dimensional stability at elevated internal pressure and temperature | To determine the propensity of the battery case and cover to be deformed by internal gas pressure |
| 4.23 | Stability against mechanical abuse of units during installation | To determine the propensity of the battery case to fracture or leak when dropped. |

2.5 Test requirements

The requirements to be fulfilled by cells and monoblocs with each test of the three groups of test clauses are established in Section 2 (being drafted separately) of the standard IEC 60896-2.

The test requirements for safety characteristics will be on a pass or fail or inform basis.

The test requirements for performance or durability characteristics will depend not only on the general category of intended use of the battery (Telecom, UPS, Emergency DC Power) but also on the particular sub-uses within each application.

For example, the test requirements for a “Stationary VRLA battery for an outdoor radio base station” in the general “Telecom” category will be different from those for a “Stationary VRLA battery for a Central Office”. Similarly, the test requirements for “Stationary VRLA battery for centralized uninterruptible AC power” in the general “UPS” category will be different from those for a “Stationary VRLA battery for dedicated computer UPS”.

This application-specific determination of the test requirements ensures that a particular product range of Stationary Lead-Acid Batteries of the Valve Regulated Type will be suitable for a particular battery user, duty and application.

3 Test set-up

Accuracy of measuring instruments

3.1.1 Voltage measurements

The instruments used shall be of an accuracy class equal to 0.5 or better. The resistance of the voltmeters shall be at least 1000 Ohm/V.

3.1.2 Current measurements

The instruments used shall be of an accuracy class equal to 0.5 or better.

3.1.3 Temperature measurement

The instruments used shall have a resolution of 1°C. The absolute accuracy of the instruments shall be 1°C or better.

NOTE

As the electrolyte temperature cannot be measured directly in valve regulated cells and monoblocs, an alternative measuring point shall be chosen for giving a temperature reading as close as possible to that of the electrolyte. The preferred point of measurement shall be the negative terminal or the cell wall in contact of the plates.

3.1.4 Time measurements

The instruments used shall have of an accuracy of $\pm 0.1\%$ or better.

3.1.5 Length measurements

The instruments used shall have an accuracy of $\pm 1\%$ or better.

3.1.6 Weight measurements

The instruments used shall have an accuracy of $\pm 1\%$ or better.

3.1.7 Gas volume measurements

The instruments used shall have an accuracy of $\pm 5\%$ or better.

3.1.8 Gas pressure measurements

The instruments used shall have an accuracy of $\pm 1\%$ or better.

The selection of the test units.

3.2.1 The units to be used for type testing according to this part of IEC 60896 shall be selected in accordance with the procedures as follows:

3.2.2 Step 1: The product ranges in a manufacturers product portfolio shall be defined by using the description of a product range as formulated above. If a product range is manufactured in multiple locations, the product from each location is deemed to be from a separate range.

3.2.3 Step 2: The representative cell or monobloc (model) of each product range shall be selected such that the representative model has combined features that are most critical for the outcome of the greatest number of tests. Generally, units with the highest unit voltage, highest capacity or largest size in a product range shall be selected for the test.

3.2.4 Step 3: These so defined representative models shall be declared, in appropriate technical documentation of the product range, as the sole representative of the entire product range.

3.2.5 Step 4: The test units (samples of the representative model) shall be selected from regular, ISO or equivalent quality-assured production and marked immediately as "60896-2 Test Unit" with indelible, handwritten and distinctive numbers of at least 30mm height on the unit cover

3.2.6 Step 5: The date of production (MM.YY) of the test units shall be reported in the relevant test documentation.

3.2.7 Step 6: The selected test units shall not be stored for more than three months after electrolyte filling and the eventual storage conditions shall be exclusively those specified in the appropriate technical documentation of the product range and reported in the relevant test documentation.

3.2.8 Step 7: The test units shall not be subjected to exceptional conditioning or commissioning treatments beyond or above that specified in the relevant technical documentation of the product range.

Such non-admissible conditioning treatments are, for example, repetitive charge/discharge cycling, high temperature storage and similar procedures.

3.3 General test features and rules

3.3.1 The test units shall not undergo any maintenance operations such as water or electrolyte additions or withdrawals during the entire duration of a test.

3.3.2 The test units shall be tested upright or in the position specified by the manufacturer in the relevant technical documentation of the product range except for those cases in which a particular position is specified in the test clause. The position used in any given test shall be reported in the relevant test documentation.

3.3.3 The test units shall always be tested fully charged with the method and duration of charge being exclusively that specified by the manufacturer in the relevant technical documentation of the product range except for those cases in which a particular method or duration is specified in the test clause. The charge methods and duration used in each test shall be reported in the relevant test documentation.

3.3.4 Whenever there is a significant change in a specified design feature, material, manufacturing process, relevant quality inspection and test procedures and manufacturing location(s) of a product range previously qualified per this part of IEC 60896, the relevant type test(s) shall be repeated to ensure that the affected product range continues to be in compliance with the Safety, Performance and Durability requirements for the intended application.

3.3.5 Each test and test set-up shall be documented with photographs that have a clear image of the test units and their identification numbers.

3.4 Customer test

3.4.1 The test units to be used for acceptance or commissioning tests shall be selected and defined in a joint agreement between the battery supplier and battery user.

3.5 Number of test units

3.5.1 The number of units to be tested is listed below.

Safety characteristics

| Test Clause | Measure | Number of test units |
|-------------|--|---------------------------|
| 4.1 | Gas emission intensity | 6 cells or 3 monoblocs |
| 4.2 | High current tolerance | 3 cells or 3 monoblocs |
| 4.3 | Short circuit current and internal resistance | 3 cells or 3 monoblocs |
| 4.4 | Protection against short circuit at terminals during transport | 1 cell or 1 monobloc |
| 4.5 | Protection against internal ignition from external spark sources | 3 cells or 3 monoblocs |
| 4.6 | Protection against ground short propensity | 4 cells or 4 monoblocs |
| 4.7 | Presence and durability of required markings | 3 cover or 3 case samples |
| 4.8 | Material identification | 1 cover or 1 case sample |
| 4.9 | Valve operations | 3 cells or 3 monoblocs |
| 4.10 | Flammability rating of materials | 1 material sample |
| 4.11 | Intercell connector performance | 6 cells or 6 monoblocs |

Performance characteristics

| Test Clause | Measure | Number of test units |
|-------------|--|------------------------|
| 4.12 | Discharge capacity | 6 cells or 6 monoblocs |
| 4.13 | Charge retention during storage | 6 cells or 6 monoblocs |
| 4.14 | Float service with frequent discharges | 6 cells or 6 monoblocs |
| 4.15 | Recharge behavior | 6 cells or 6 monoblocs |

Durability characteristics

| Test Clause | Measure | Number of test units |
|-------------|--|------------------------------|
| 4.16 | Float service capability at an operating temperature of 40 °C | 3 cells or 3 monoblocs |
| 4.17 | Float service capability at a stress operating temperature of 55 °C or 60 °C | 3 cells or 3 monoblocs |
| 4.18 | Overcharge endurance | 3 cells or 3 monoblocs |
| 4.19 | Abusive over-discharge | 4+3 cells or 4+3 monoblocs |
| 4.20 | Thermal runaway sensitivity | 2x 4 cells or 2x 4 monoblocs |
| 4.21 | Low temperature sensitivity | 3 cells or 3 monoblocs |
| 4.22 | Dimensional stability at elevated internal pressure and temperature | 1 cell or 1 monobloc |
| 4.23 | Stability against mechanical abuse of units during installation | 3 cells or 3 monoblocs |

3.6 Suggested test sequence

The suggested test sequence is shown below. Multiple tests on the same units are allowed. However, the test sequence should be planned carefully to ensure that the execution of one test does not unduly influence the outcome of a subsequent test. In some cases, a test clause may proscribe sequence of tests. Separate units may be used for each test unless the sequence for a test unit is specified in a test clause. The manufacturer makes the final decision on the test sequence. The adopted test sequence must be recorded in the relevant test documentation.

| Suggested test sequence | | | | | |
|-------------------------|--|--|------|------|------|
| Groups of test samples | | Sequence of tests according to indicated clauses | | | |
| Set 1 | Carry out a C ₃ capacity test to 1.75Vpc to verify a capacity compliance of ≥ 100% of rated before each test except when otherwise specified, proscribed or not required. | 4.4 | 4.1 | 4.3 | 4.2 |
| Set 2 | | 4.5 | 4.6 | | |
| Set 3 | | 4.7 | 4.8 | 4.10 | |
| Set 4 (5x 6 units) | | 4.12 | 4.11 | 4.13 | 4.14 |
| Set 5 | | 4.16 | 4.15 | | |
| Set 6 | | 4.17 | 4.9 | | |
| Set 7 | | 4.18 | | | |
| Set 8 | | 4.19 | | | |
| Set 9 | | 4.20 | | | |
| Set 6 | | 4.21 | | | |
| Set 7 | | 4.22 | | | |
| Set 8 | | 4.23 | | | |

4 Test methods

4.1 Gas emission intensity

4.1.1 The test shall be carried out with six cells or three monoblocs.

4.1.2 The test units shall be selected and prepared according to clause 3.2.

4.1.3 The test units shall be tested connected in series and maintained during the test between 20 °C and 25 °C (temperature of test unit) and fitted with a gas collection device so that the emitted gas can be collected over several days and its volume determined with the required accuracy.

4.1.4 The gas collection shall be carried out, for example, with a gas collection device similar to that shown in Fig.1. Careful attention must be paid to ensure leak-free gas transport from the test units to the collection device during long unattended operation and under a maximum hydrostatic head of 20 mm (as given by the difference in collection vessel immersion depth and water level) to collect an adequate sample volume.

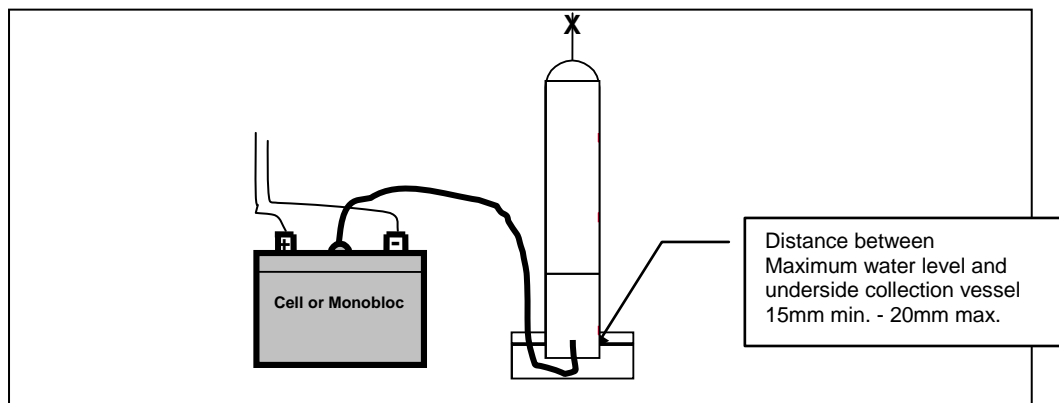

Fig. 1 Suitable layout for the test

4.1.5 The test units shall have, before starting the test, an actual capacity C_a of at least C_{rt} (3 h - 1.75 Vpc at the selected reference temperature), be fully charged and then float charged for 72 h \pm 0.1 h with the manufacturers specified float voltage U_{flo} with a precision of \pm 0.01 Vpc.

4.1.6 After 72 h \pm 0.1 h of float charge, the gas collection shall commence and the collection of gas continued for four periods each of 168 h \pm 0.1 h duration.

4.1.7 The cumulative total gas volume collected (V_a in ml) over each of the four periods of 168 h \pm 0.1 h shall be recorded together with the ambient temperature T_a (in °C) and the ambient pressure P_a (in kPa) at which each determination of the gas volumes was made.

4.1.8 The corrected volume of gas V_n emitted per test unit at the reference temperature of 20 °C or 25 °C and the reference pressure of 101.3 kPa shall be calculated by the formula (ignoring correction for water vapor pressure)

$$V_n = \frac{V_a \times T_r \times P_a}{T_a \times P_r} \text{ in ml}$$

where

| | |
|-------|--|
| V_a | is the cumulative total gas collected in ml |
| T_r | is the reference temperature in K (at 20 °C or 25 °C) |
| T_a | is the ambient temperature in K ($T_a = 273 + T_a$ in °C) |
| P_a | is the ambient atmospheric pressure in kPa |
| P_r | is the corrected pressure in kPa |

4.1.9 The normalized gas emission G_e per cell at float charge voltage conditions shall be calculated for each of the four 168h \pm 0.1h periods with the formula below:

$$G_e = V_n / (n \times 168 \times C_{rt}) \quad \text{in ml per cell, hour and rated } C_3 \text{ Ah}$$

where

| | |
|----------|---|
| V_n | is the total corrected gas volume emitted per test unit in ml |
| n | is the number of cells from which the gas was collected in the collection vessel |
| 168 | the number of hours during which the gas was collected |
| C_{rt} | is the rated C_3 capacity in Ah of the test units from which the gas was collected. |

The individual, the average and the three standard deviations value of the normalized gas emission of the test units during each of the four $168 \text{ h} \pm 0.1 \text{ h}$ of the test shall be reported.

4.1.10 The charge voltage of the same test units shall be increased to $2.40 \text{ Vpc} \pm 0.01 \text{ Vpc}$

4.1.11 After $24 \text{ h} \pm 0.1 \text{ h}$ of charge at $2.40 \text{ Vpc} \pm 0.01 \text{ Vpc}$ the gas collection shall commence and the collection of gas continued for one periods of $48 \text{ h} \pm 0.1 \text{ h}$ duration.

4.1.12 The cumulative total gas volume collected (V_a in ml) over one period of $48 \text{ h} \pm 0.1 \text{ h}$ shall be recorded together with the ambient temperature T_a (in °C) and the ambient pressure P_a (in kPa) at which the determination of the gas volumes was made.

4.1.13 The corrected volume of gas V_n emitted per test unit at the reference temperature of 20 °C or 25 °C and the reference pressure of 101.3 kPa shall be calculated by the formula (ignoring correction for water vapor pressure)

$$V_n = \frac{V_a \times T_r}{T_a} \times \frac{P_a}{P_r} \text{ in ml}$$

where

| | |
|-------|--|
| V_a | is the cumulative total gas collected in ml |
| T_r | is the reference temperature in K (at 20 °C or 25 °C) |
| T_a | is the ambient temperature in K ($T_a = 273 + T_a$ in °C) |
| P_a | is the ambient atmospheric pressure in kPa |
| P_r | is the normalized pressure in kPa |

4.1.14 The normalized gas emission G_e per cell at elevated charge voltage (2.40 Vpc) conditions shall be calculated for the $48 \text{ h} \pm 0.1 \text{ h}$ periods with the formula below:

$$G_e = V_n / (n \times 48 \times C_{rt}) \text{ in ml per cell, hour and rated } C_3 \text{ Ah}$$

where

| | |
|----------|---|
| V_n | is the corrected gas volume emitted per test unit in ml |
| n | is the number of cells from which the gas was collected in the collection vessel |
| 48 | the number of hours during which the gas was collected |
| C_{rt} | is the rated C_3 capacity in Ah of the test units from which the gas was collected. |

The individual, the average and the three standard deviations value of the normalized gas emission of the test units during each of the $48 \text{ h} \pm 0.1 \text{ h}$ of the test shall be reported.

NOTE

Although the emitted gas may contain some oxygen, for safety purposes all emitted gas is considered to be hydrogen.

4.2 High current tolerance

4.2.1 The test shall be carried out with three cells or three monoblocs.

4.2.2 The test units shall be selected and prepared according to clause 3.2.

4.2.3 The test units shall have, before starting the test, an actual capacity C_a of at least C_{rt} ($3 \text{ h} - 1.75 \text{ Vpc}$ at the selected reference temperature), be fully charged and have unit temperature between 20 °C and 25 °C .

4.2.4 The test units shall be discharged for the specified duration with a current equal to 3 times the rated 5 minute current (rating to 1.80 Vpc at 20 °C or 25 °C) or with a current equal to 3 times the maximum discharge current, both as specified by the manufacturer in the relevant technical documentation of the product range.

NOTE

During the test the necessary precaution against damage from cell explosions, electrolyte and molten lead projectiles shall be taken.

4.2.5 After the completion of the specified discharge duration (see Section 2 of IEC 60896-2 being drafted separately), the test units shall stand for 5 minutes in open circuit and their voltage measured and reported.

4.2.6 The test units shall be examined, after the discharge, internally and externally for signs of incipient melting and the conditions found reported and documented photographically.

4.3 Short-circuit current and internal resistance

4.3.1 The test shall be carried out with three cells or three monoblocs.

4.3.2 The test units shall be selected and prepared according to clause 3.2.

4.3.3 The test units shall have, before starting the test, an actual capacity C_a of at least C_{rt} (3 h - 1.75 Vpc at the selected reference temperature), be fully charged and have unit temperature between 20 °C and 25 °C.

NOTE

This test is designed to yield values of the possible short circuit current (accuracy $\pm 10\%$) capable to be delivered from the cell and monobloc when the external circuit has a negligible resistance compared to that of the unit itself.

The test also yields the values of the internal (DC) resistance of the cell or monobloc when this value is derived from the voltage vs. I relationship during a discharge with current pulses of a defined magnitude.

The values of short circuit current and internal resistance are used for the sizing of safety devices such as fuses. It shall be noted that the short circuit current of a fully discharged unit is approximately 60% of that of a fully charged unit.

4.3.4 The voltage of the test units shall be measured at the terminals of each test unit in order to make sure that no external voltage drop interferes with the test result. A suitable circuit is given in Fig.2

4.3.5 The high current discharge capability $U = f(I)$ or short circuit current shall be defined by determining two of its points the following way:

a) First point (U_1, I_1)

After 20 s of discharge at the current $I_1 = 4x I_{10}$ the voltage and current shall be recorded to give the first point

The current shall be interrupted after 25 s maximum and, without recharge and after an open circuit stand of 5 min, the second point shall be determined.

b) Second point (U_2, I_2)

After 5s of discharge at the current $I_2 = 20x I_{10}$ the voltage and current shall be recorded to give the second point.

NOTE

When testing very large units and when the test current $20 I_{10}$ is beyond the capability of the test equipment it is acceptable to extrapolate the values of I_{sc} and R_i from measurements carried out on units of smaller Ah capacity but of the same design.

4.3.6 The characteristics $U = f(I)$ shall be linearly extrapolated to $U = 0$. The intercept indicates the high current discharge capability or short-circuit current I_{sc} . The internal resistance R_i shall also be determined.

The appropriate formulas for this interpolation are:

$$\text{Short circuit current } I_{sc} = (U_1 \times I_2) - (U_2 \times I_1) / (U_1 - U_2) \quad \text{in Ampere}$$

$$\text{Internal resistance } R_i = (U_1 - U_2) / (I_2 - I_1) \quad \text{in Ohm}$$

The individual, the average and the three standard deviations value of I_{sc} and R_i shall be reported.

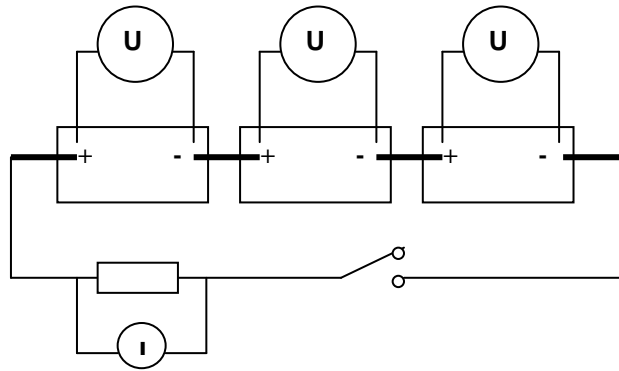

Fig 2. Suitable circuit layout for the test

4.4 Protection against short circuit at terminals during transport

4.4.1 The test shall be carried out on a sample of one fully charged cell or monobloc of the product range.

NOTE

This test is designed to reveal the degree of protection provided during transport by the terminal protection supplied by the manufacturer.

4.4.2 The unit shall be equipped with the protection designed/supplied by the manufacturer for preventing short circuits across the terminals during shipment.

4.4.3 With a straight metallic rod, of 3 mm diameter and appropriate length, several attempts of contacting terminals of opposite polarity of the unit at once shall be made. Contact is considered achieved when, between the two ends of the metallic rod separated in their middle by an insulator and as shown below, a voltage equal or greater than 2V is found.

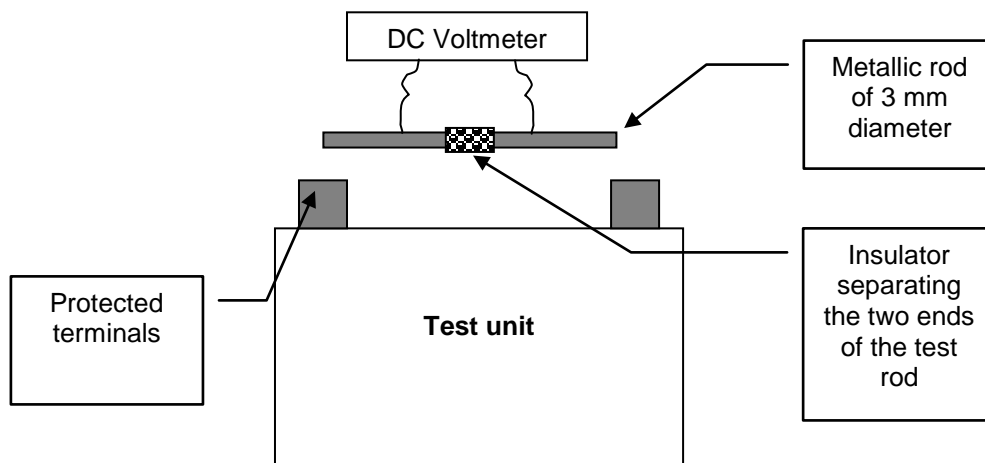

Fig 3 Suitable layout for the test

4.4.4 The terminal protection of the unit used in the test shall be described/depicted together with the achievement or non-achievement of an electrical contact between terminals of opposite polarity of the same unit with the above test rod.

4.5 Protection against internal ignition from external spark sources

4.5.1 The test shall be carried out with three cells or three monoblocs.

4.5.2 The test units shall be selected and prepared according to clause 3.2.

4.5.3 The test units shall have, before starting the test, an actual capacity C_a of at least C_{rt} (3 h - 1.75 Vpc at the selected reference temperature), be fully charged and have a unit temperature between 20 °C and 25 °C.

NOTE

This test is designed to reveal the resistance of the unit to the ignition of the gases within by an external ignition source.

In this test, proper precautions must be taken to safeguard personnel and equipment from explosion hazards and burns.

4.5.4 The test shall be carried out under the guidance of the safety procedures described in the Technical Report IEC 61430(1997).

4.5.5 The fully charged units shall be overcharged with a constant current of equal to I_{10} (C_{10} to 1.80 Vpc at either 20 °C or 25 °C) for 60 minutes.

4.5.6 Under continued overcharge conditions six electric sparks or air discharges shall each be generated at 10s interval at less than 10 mm \pm 5 mm distance in the direction of the gas flow and at any structural discontinuity or features through which gas could exit from the unit. Such features are valve or gas outlet openings, terminals, the case-to-cover seals, gas collection manifolds and tubing etc.

4.5.7 The electric sparks of at least 0.02mJ across a gap or 0.5 to 2.0mm shall be generated with a suitable device that has demonstrated capability to ignite hydrogen-oxygen mixtures. Such devices include an automotive ignition coil and spark plug or a fuse capable of controlled rupture to create a spark.

4.5.8 Each tested feature of the units shall be reported/depicted together with the occurrence or non-occurrence, of combustion and explosions inside the units and gas collection manifolds.

4.6 Protection against ground short propensity

4.6.1 The test shall be carried out with four cells or four monoblocs.

4.6.2 The test units shall be selected and prepared according to clause 3.2.

4.6.3 The test units shall have, before starting the test, an actual capacity C_a of at least C_{rt} (3 h - 1.75 Vpc at the selected reference temperature), be fully charged and have unit temperature between 20 °C and 25 °C.

NOTE

This test is designed to determine the resistance of the unit to the development of current flow paths through seals and other points of structural discontinuity.

The necessary safety precautions against high voltage and ground short phenomena shall be taken.

4.6.4 The units shall be placed in all four possible horizontal positions and their case to cover seal line placed in contact with a metallic surface. This contact can be achieved for example by taping an aluminum foil strip onto the seal line. If the test unit is cylindrical in design, the four units shall be tested such that four different sections (as determined by the orientation of the unit's terminals) of the seal area are in contact with the metallic surface.

4.6.5 The units shall be connected, if desired also in parallel, to a circuit which applies a DC voltage of at least 500 V \pm 5 V between one terminal and the metallic surface (aluminum foil strip) in contact with the seal line. A suggested test circuit is shown in Fig. 5 below.

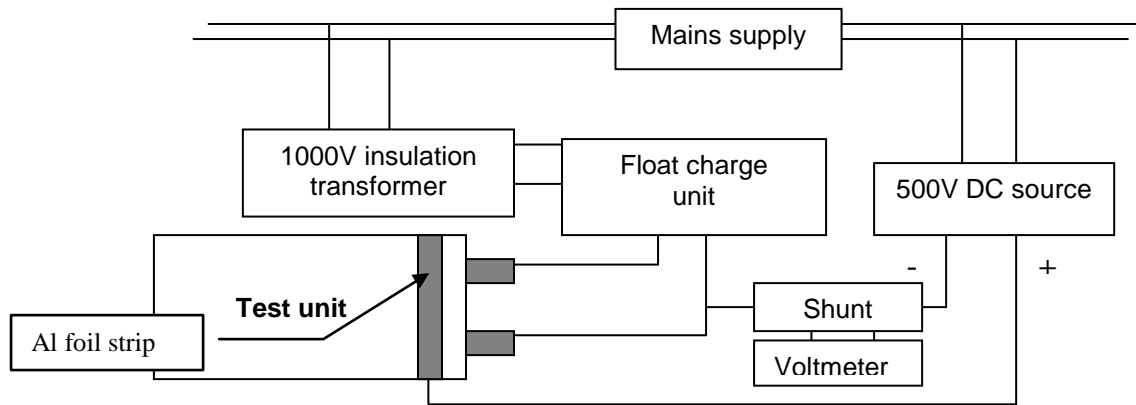

Fig 5 Suggested test circuit for the evaluation of ground short propensity

4.6.6 The negative terminal of the DC voltage source shall be connected to the terminal of the unit(s) and the positive terminal to the metallic surface (aluminum foil strip)

4.6.7 One unit each shall be placed in a different horizontal position and float charged with the unit temperature between 20°C and 25°C

4.6.8 The shunt shall be of such a size that a current greater than 0.1 mA flowing through the shunt shall be detectable and recorded with appropriate means.

4.6.9 The units shall be tested in this position for 30 days or until ground short current flow is detected whichever comes first.

4.6.10 A ground short conditions is considered to be present when acid leakage is detected visually and/or the leakage current is $\geq 1 \text{ mA} \pm 0.1 \text{ mA}$

4.6.11 The individual, average and the three standard deviations value of time in hours to, and location of the ground short, if any, of the four units shall be reported.

4.7 Presence and durability of required markings

4.7.1 The test shall be carried out with three cases and/or covers used in the test unit having all the required markings in their definitive size, form, material and execution. Required markings may be molded into the case or cover or included on a label affixed to the case or cover.

4.7.2 The test shall consist of visual verification for the presence and legibility of all the required markings before and after exposure to selected chemicals.

4.7.3 The durability of the marking shall be tested, consistent with IEC 60950 Section 1.7.15, 2000, as follows:

Water and aliphatic solvent.

a) The labels and marking shall be rubbed for 15s with a piece of cloth soaked with water and again for 15s with a piece of cloth soaked with petroleum spirit and then inspected visually.

b) The petroleum spirit used for this test shall be hexane (C_6H_{14} – Alcan C_6) with an initial boiling point of 65°C, a dry point of approximately 69°C, a density of 0.7Kg/l and a maximum aromatics content of 0.1% per volume.

Neutralizing solutions

- a) The labels and marking shall be rubbed for 15s with a piece of cloth soaked with a saturated solution of sodium carbonate in water, dried in air and then inspected visually.

Electrolyte

- a) The labels and marking shall be rubbed for 15s with a piece of cloth soaked with a solution of 40% in weight of H₂SO₄ in water, washed with water, dried in air and then inspected visually.

4.7.4 Each required marking shall be visually inspected, fully described and depicted photographically before and after the application of the test chemical.

4.8 Material identification

4.8.1 The test shall be carried out with one cell or one monobloc and with one intercell connector cover having all the specified information applied in its definitive size, form, material and execution.

4.8.2 The specified information for material identification shall be selected from the list of abbreviation published in the standard ISO 1043-1 1997.

4.8.3 The case and cover shall be visually inspected for marking showing an ISO 1043-1 defined abbreviation of the name of the polymer(s) forming at least 95% of the material bulk weight of the case and cover.

4.8.4 The intercell connector cover shall be inspected visually for marking showing an ISO 1043-1 defined abbreviation of the name of the polymer(s) forming at least 95% of the material bulk weight of the connector cover.

4.8.5 The stability of the marking shall be tested, if needed, with the test outlined in the clause 4.7

4.9 Valve operation

4.9.1 The test shall be carried out with the units destined for the test clause 4.17, Float service capability, at a stress-temperature of 55 °C or 60 °C

4.9.2 The units shall be tested for valve opening before and at the conclusion of the float service test at 55 °C or 60 °C as follows:

- a) The units shall be fully charged and at a unit temperature between 18 °C to 27 °C.
- b) The units shall be overcharged with a constant voltage between 2.60 Vpc to 2.70 Vpc.
- c) A gas collection cover shall be placed sequentially onto each valve opening in such a way that all gas released from that valve is captured.
- d) If the valve openings are hidden by, or integrated in, a gas collection cover or manifold, gas flowing from the outlet of this cover or manifold shall be collected.
- e) A tubing shall carry the gas from this collection cover to a U-shaped glass tubing of about 15mm diameter and with the bottom of the U filled with water. See also Fig. 10.
- f) The correct opening of each valve shall be verified visually by detecting the released gas bubbling through the liquid at the bottom of the U-shaped glass tubing.

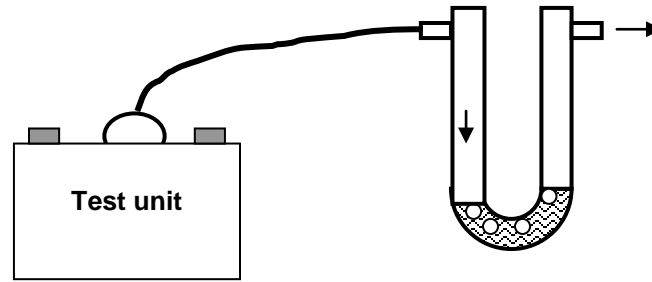

Fig. 10 U-shaped tubing for gas flow detection

4.9.3 The adequate valve opening before and after the test of clause 4.17 shall be reported.

NOTE

For proper operation of a stationary VRLA battery no air shall enter through the valve when a slight vacuum is present in the cell interior. The adequate valve seal performance of the valve can be tested by creating a vacuum of -80 kPa and confirming, once the vacuum line is disconnected, that a negative pressure remains for 24h hours and the leak rate observed does not interfere with proper operation of the cell or monobloc.

4.10 Flammability rating of materials

4.10.1 The test shall be carried out with appropriately sized samples of the material used for the manufacture of the cell or monobloc case, the cell and monobloc cover and the intercell connector cover.

4.10.2 The test method used shall be in accordance with the IEC standard 60707 Flammability of non-metallic materials when exposed to flame sources and IEC 60695-11-10 Fire hazard testing Part 11-10 Test flames 50W horizontal and vertical test methods or an equivalent test method.

4.10.3 The test shall be carried out by an appropriate test laboratory and the results and classification appear in a signed and dated test certificate.

NOTE

This test gives an indication of the burning behavior under defined test conditions and specimen sizes. The actual burning behavior of the cell and monobloc case, cover or terminal and intercell connector covers may differ.

4.11 Intercell connector performance

4.11.1 The test shall be carried out on the units destined for the test clause 4.12 Capacity test at the $C_{0.25}$ or 0.25h rate with current $I_{0.25}$ to $U_f = 1.60$ Vpc or alternatively with the highest discharge current for a particular unit and intercell connector size as specified by the manufacturer in the relevant technical documentation of the product range

4.11.2 The shape, size and construction details as also the individual, the average and the three standard deviation value of the maximum temperature of the intercell connector reached during the discharge test shall be reported.

NOTE

This test gives an indication of the temperature to be expected during a high rate - short duration discharge. In mission critical installations (UPS battery service) the temperature reached under actual discharge conditions is essential to determine if potential hazards exist.

4.12 Discharge capacity

4.12.1 The test shall be carried out with five times six cells or six monoblocs.

4.12.2 The test units shall be selected and prepared according to clause 3.2.

4.12.3 The test shall be carried out at each of the following discharge rates with six fully charged units used for the first time for each of the discharges

The capacities shall be determined with the following rates to the following end-of-discharge voltages:

| | | | | |
|------------|------------|-------------------------|---------------------|-----------------------|
| C_{10} | 10h rate | with current I_{10} | to $U_f = 1.80$ Vpc | ($\lambda = 0.006$) |
| C_8 | 8h rate | with current I_8 | to $U_f = 1.75$ Vpc | ($\lambda = 0.006$) |
| C_3 | 3h rate | with current I_3 | to $U_f = 1.70$ Vpc | ($\lambda = 0.006$) |
| C_1 | 1h rate | with current I | to $U_f = 1.60$ Vpc | ($\lambda = 0.01$) |
| $C_{0.25}$ | 0.25h rate | with current $I_{0.25}$ | to $U_f = 1.60$ Vpc | ($\lambda = 0.01$) |

4.12.4 The test shall be carried with the units fully charged and with each unit temperature between 18 °C and 27 °C measured immediately prior the discharge.

This initial temperature v of the unit shall used for the correction of its capacity in function of temperature..

NOTE

It is desirable that the initial average cell or monobloc temperature and the ambient temperature are as near to the reference temperature of either 20 °C or 25 °C as practically possible.

4.12.5 The discharge shall be started within 1h to 24h after termination of charge and with the discharge current I_{dis} held constant within 1% throughout the whole discharge duration.

4.12.6 The voltage found between the terminals, including one intercell connector, of all the units shall be either recorded automatically against time or taken by readings from a voltmeter. In the latter case readings shall be made at least at 25%, 50% and 80% of the calculated discharge time with

$$t = C_{rt} / I_{rt} \text{ (h)}$$

and then at suitable time intervals, which permits the detection of the transition to the final discharge voltage U_f .

4.12.7 In a type test for the determination of the discharge capacity (this clause) with five discharge rates, the discharge shall be terminated when all of the following results have been recorded:

- The elapsed time of discharge of each unit with n cells to a final voltage of $n \times U_f$ (V)
- The elapsed time of discharge of the string with 6 units to a voltage of $6 \times n \times U_f$ (V)
- The voltage of each of the 6 units when the string reached a voltage of $6 \times n \times U_f$ (V)

4.12.8 The individual, the average and three standard deviations value of each of the parameters a), b) and c) shall be reported.

4.12.9 In the type test for determination of the discharge capacity C_a preceding or following a particular test routine the discharge shall be terminated, if not specified otherwise, when the elapsed time of discharge of each unit with n cells to a final voltage of $n \times U_f$ (V) has been recorded.

4.12.10 In an acceptance or commissioning test the discharge shall be terminated when the following result has been recorded:

- a) The elapsed time of discharge of the string with n cells to a voltage of $n \times U_f$ (V)
 or
 b) The elapsed time of discharge of a monobloc with n cells in the string to a voltage of $(U_f - \sqrt{n} \times 0.2)$ V

whichever comes first or as agreed between the battery manufacturer and the battery user.

4.12.11 The measured capacity C (Ah) at the initial temperature v shall be calculated as the product of the discharge current (A) and the discharge time (h).

4.12.12 If the initial temperature v is different from the reference temperature of either 20°C or 25°C, the measured capacity shall be corrected by means of the following equation to obtain the actual capacity C_a at the selected reference temperature:

$$C_{a20^\circ\text{C}} = C / [1 + \lambda (v - 20)] \text{ in Ah} \quad \text{or} \quad C_{a25^\circ\text{C}} = C / [1 + \lambda (v - 25)] \text{ in Ah}$$

The coefficient λ shall be taken as shown in clause 4.12.3.

4.13 Charge retention during storage

4.13.1 The test shall be carried out with six cells or six monoblocs.

4.13.2 The test units shall be selected and prepared according to clause 3.2.

4.13.3 The test units shall have, before starting the test, an actual capacity C_a of at least C_{rt} (3 h - 1.75 Vpc at the selected reference temperature) and be fully charged.

4.13.4 The units shall be stored at an ambient temperature as close as possible to 25°C and fully disconnected from any external circuit.

4.13.5 After 180 days of storage the units shall be discharged without any prior recharge so that their actual capacity after storage C_{ast} (3 h - 1.75 Vpc at the selected reference temperature) can be determined.

4.13.6 The charge retained C_r shall be expressed as percentage, and is equal to

$$C_r = (C_{ast} \times 100) / C_a \quad (\%)$$

where C_a is the actual capacity of the units determined before the 180 days of storage.

4.13.7 The individual, the average and the three standard deviations value of C_r shall be reported.

4.14 Float service with frequent discharges

4.14.1 The test shall be carried out with six cells or six monoblocs.

4.14.2 The test units shall be selected and prepared according to clause 3.2.

4.14.3 The test units shall have, before starting the test, an actual capacity C_a of at least C_{rt} (3 h - 1.75 Vpc at the selected reference temperature) and be fully charged.

4.14.4 The units shall be connected to a device whereby they undergo a series of discharge and charge cycles, each cycle comprising:

- a) A discharge for 2 h or to a final voltage of 1.80 Vpc, whichever comes first, with a current of $I=2.0I_{10}$ maintained constant within $\pm 1\%$ where $I_{10}=C_{10}/10$ in A and followed immediately by
- b) A charge for 22 h with a current limited to $I=2.0I_{10}$ and a voltage limited to the float voltage specified by the manufacturer for either 20 °C or 25 °C.
- c) The cells and monoblocs shall be operated at a temperature between 18 °C and 27 °C and the discharge - charge cycle routine a) and b) continued until, during a discharge, a voltage of 1.80 Vpc is reached in a shorter time than 2h.
- d) The number of cycles achieved with the discharge - charge cycle routine a) and b) shall be recorded.

NOTE

This number represents the amount of cycles which can be achieved in one single sequence without any boost charge treatment and when the unit is subjected to a 24 h back-to-back sequence of discharges to 40% d.o.d (C_{10}) followed by 22h of charge and when recharged exclusively with the maximum charge voltage equivalent to the float voltage. This test is designed to more closely duplicate the type of cycle service a battery experiences during constant voltage float service where no boost charge mode is available.

- e) The units having reached the conditions outlined in c) shall then be subjected for 168 h \pm 0.1 h to a charge with a current limited to $I=2.0I_{10}$ and a voltage limited to the float voltage specified by the manufacturer for either 20 °C or 25 °C.
- f) At the end of the 168 h \pm 0.1 h of charge, the units shall be subjected immediately to a capacity test with a constant current of $I=I_3$ to 1.75 Vpc and the capacity C_{af} corrected to 20 °C or 25 °C and recorded. This value C_{af} represents the capacity available when units are, after numerous cycles, subjected to a prolonged period of charge with a charge voltage equivalent to the float voltage.
- g) At the conclusion of the capacity test outlined in f) the units shall be fully charged and then subjected to a equalization or boost charge according to the manufacturers specifications. At the conclusion of this equalization or boost charge treatment the units shall be subjected immediately to a capacity test with a constant current of $I=I_3$ to 1.75 Vpc and the capacity C_{ab} corrected to 20 °C or 25 °C and recorded. This value C_{ab} represents the capacity available when the units are, after numerous cycles, subjected to a manufacturer specific equalization or boost charge treatment

4.14.5 The test results:

- a) Number of cycles achieved before reaching 1.80 Vpc during the 2 h of discharge
- b) Capacity C_{af} expressed in % of C_{rt} after 168 h float charge
- c) Capacity C_{ab} expressed in % of C_{rt} after manufacturers specified boost charge

shall be reported as the individual, the average and three standard deviations value of a), b) and c).

NOTE

This test is designed to more closely duplicate the type of cycle service a battery experiences during constant voltage float service where no boost charge mode is available. The cycling performance expressed in cycles to approx. 40% residual capacity is governed by charge acceptance and acid stratification phenomena.

The values of C_{af} and C_{ab} in % of C_{rt} reveal how the above encountered capacity walk-down is reversible either by prolonged charge or by boost charge treatments suggested by the manufacturer for the battery under test.

4.15 Recharge behavior

4.15.1 The test shall be carried out with six cells or six monoblocs.

4.15.2 The test units shall be selected and prepared according to clause 3.2.

4.15.3 The test units shall have, before starting the test, an actual capacity C_a of at least C_{rt} (3 h - 1.75 Vpc at the selected reference temperature) and be fully charged.

4.15.4 The units shall be discharged, with all unit temperatures between 18 °C to 27 °C, and a constant current of $I=I_{10}$, to 1.80 Vpc. This capacity C_a value shall be corrected to 20 °C or 25 °C.

4.15.5 After the discharge and a 1 h \pm 0.1 h stand in the discharged state, the units shall be recharged with a current limited to $I=2.0I_{10}$ and a voltage limited to the float voltage specified by the manufacturer for either 20 °C or 25 °C.

4.15.6 After 24 h \pm 0.1 h of charge the units shall be immediately discharged again with a current of I_{10} to 1.80 Vpc. This capacity value C_{a24} shall be corrected to 20 °C or 25 °C.

4.15.7 The percent capacity found after 24 h of charge shall be expressed as percentage of the initial actual capacity as follows:

$$C_{24h} \% = (C_{a24} \times 100) / C_a$$

4.15.8 The units shall be fully recharged and then again discharged, with all unit temperatures between 18 °C to 27 °C and a constant current of $I=I_{10}$, to 1.80 Vpc. This capacity C_a value shall be corrected to 20°C or 25°C.

4.15.9 After the discharge and a 1 h \pm 0.1 h stand in the discharged state, the units shall be recharged with a current limited to $I=2.0I_{10}$ and a voltage limited to the float voltage specified by the manufacturer for either 20 °C or 25 °C.

4.15.10 After 168 h \pm 0.1 h of charge the units shall be immediately discharged again with a current of I_{10} to 1.80 Vpc. This capacity value C_{a168} shall be corrected to 20 °C or 25 °C.

4.15.11 The percent capacity found after 168h charge shall be expressed as percentage of the initial actual capacity as follows:

$$C_{168h} \% = (C_{a168} \times 100) / C_a$$

4.15.12 The individual, the average and the three standard deviation value of C_{24h} and C_{168h} shall be reported.

NOTE

This test gives information about the recharge behavior in terms of effective available capacity after 24h and 168h of float charge and avoids reliance on data like ampere hours charged back that is irrelevant to the application.

4.16 Float service capability at an operating temperature of 40 °C

4.16.1 The test shall be carried out with three cells or three monoblocs.

4.16.2 The test units shall be selected and prepared according to clause 3.2.

4.16.3 The test units shall have, before starting the test, an actual capacity C_a of at least C_{rt} (3 h - 1.75 Vpc at the selected reference temperature) and be fully charged.

4.16.4 The units shall be float charged at the elevated temperature with the manufacturers recommended float voltage for 40°C.

4.16.5 The units shall not be outfitted with means of dimensional stabilization beyond that normally present in the cell or monobloc assembly and shown/specified in the appropriate technical documentation of the product range.

4.16.6 The units shall be placed in a hot air enclosure with the average air temperature such that the monoblocs are held at $40\text{ °C} \pm 2\text{ °C}$. The air of the chamber shall be no higher than 20% RH.

4.16.7 The units, after cooling down to room temperature under float charge, shall be subjected to a determination of their individual actual capacity C_a every $118\text{ d} \pm 3\text{ d}$ ($C_{rt}\ 3\text{ h} - 1.75\text{ Vpc}$ at the selected reference temperature).

No charge with voltages beyond the float charge voltage is admissible before or after such a capacity determination. After capacity determination, the units are returned to float charge in the hot air enclosure as in 4.16.6 for another 118 days at 40 °C . The test for a unit is terminated when the individual actual capacity of that unit is less than $0.8C_{rt}$. The remaining units continue to be tested until the actual capacity of the last unit is less than $0.8C_{rt}$.

4.16.8 The capacity values C_a shall be plotted in a graph as function of days elapsed at $40\text{ °C} \pm 2\text{ °C}$.

The intersection of the regression graph connecting the individual C_a data points with a horizontal line representing a capacity level of $0.8C_{rt}$ ($C_{rt}\ 3\text{ h} - 1.75\text{ Vpc}$ at the selected reference temperature) shall be determined in terms of elapsed days at 40 °C and reported as the individual, the average and the three standard deviation value of days elapsed.

4.17 Float service capability at a stress temperature of 55 °C or 60 °C

4.17.1 The test shall be carried out with three cells or three monoblocs.

4.17.2 The test units shall be selected and prepared according to clause 3.2.

4.17.3 The test units shall have, before starting the test, an actual capacity C_a of at least C_{rt} ($3\text{ h} - 1.75\text{ Vpc}$ at the selected reference temperature) and be fully charged.

4.17.4 The units shall be float charged at the elevated temperature with the manufacturers recommended float voltage for 20 °C or 25 °C .

4.17.5 The units can be outfitted with means of dimensional stabilization beyond that normally present in the cell or monobloc assembly and shown/specified in the appropriate technical documentation of the product range. These means shall be described.

4.17.6 The units shall be placed in a hot air enclosure with the average air temperature such that the monoblocs are held at $55\text{ °C} \pm 2\text{ °C}$ or $60\text{ °C} \pm 2\text{ °C}$. The air of the chamber shall be no higher than 20% RH.

4.17.7 The units, after cooling down to room temperature under float charge, shall be subjected to a determination of their individual actual capacity C_a every $42\text{ d} \pm 3\text{ d}$ ($C_{rt}\ 3\text{ h} - 1.75\text{ Vpc}$ at the selected reference temperature) when tested at 55 °C or every $30\text{ d} \pm 3\text{ d}$ when tested at 60 °C ($C_{rt}\ 3\text{ h} - 1.75\text{ Vpc}$ at the selected reference temperature).

No charge with voltages beyond the float charge voltage is admissible before or after such a capacity determination. After capacity determination, the units are returned to float charge in the hot air enclosure as in 4.17.6 for another 42 days at 55 °C (or 30 days at 60 °C). The test is terminated for a unit when the individual actual capacity of that unit is less than $0.8C_{rt}$. The remaining units continue to be tested until the actual capacity of the last unit is less than $0.8C_{rt}$.

4.17.8 The capacity values C_a shall be plotted in a graph as function of days elapsed at $55\text{ °C} \pm 2\text{ °C}$ or $60\text{ °C} \pm 2\text{ °C}$.

The intersection of the regression graph connecting the individual C_a data points with a horizontal line representing a capacity level of $0.8C_{rt}$ ($C_{rt}\ 3\text{ h} - 1.75\text{ Vpc}$ at the selected reference temperature) shall be determined in terms of elapsed days at 55 °C or 60 °C and reported as the individual, the average and the three standard deviation value of days elapsed.

4.18 Overcharge endurance

- 4.18.1 The test shall be carried out with three cells or three monoblocs.
- 4.18.2 The test units shall be selected and prepared according to clause 3.2.
- 4.18.3 The test units shall have, before starting the test, an actual capacity C_a of at least C_{rt} (3 h - 1.75 Vpc at the selected reference temperature) and be fully charged.
- 4.18.4 The units shall be connected to a source of current and be charged with a constant current of $I = 0.2I_{10} \pm 1\%$ (e.g. 2 A for 100 Ah C_{10} to 1.80 Vpc at 20 °C or 25 °C).
- 4.18.5 The units shall be assembled with appropriate intercell connectors ensuring an air gap between adjacent units of 10mm or as specified in the appropriate technical documentation of the product range. The temperature of the units shall be held, with air cooling only, between 20 °C to 30 °C.
- 4.18.6 After 720 h -0 h,+72 h the units shall undergo a capacity test with a constant current of $I=I_3$ to 1.75 Vpc and the capacity C_{a0} corrected to 20 °C or 25 °C and recorded.
- 4.18.7 After recharge the units shall undergo another period of 720 h -0 h,+72 h of overcharge.
- 4.18.8 The procedure outlined in 4.18.4 to 4.18.6 shall be repeated until the temperature corrected capacity C_{a0} of each unit has dropped below **0.8 C_{rt} (3 h - 1.75 Vpc at the selected reference temperature)**
- 4.18.9 The individual, the average and the three standard deviations value of the numbers of elapsed periods shall be reported.

NOTE

This test is designed to stress corrosion related aging phenomena when units are operated with poor float voltage control, frequent boost charges and in a hot operating environment. The selected test condition result in a float voltage of about 2.35 Vpc to 2.40 Vpc and an operating temperature of approx. 30°C. A test duration to failure of 200 to 400 days is typically encountered.

4.19 Abusive over-discharge

- 4.19.1 The test shall be carried out with the number of units shown below.
- 4.19.2 The test units shall be selected and prepared according to clause 3.2.
- 4.19.3 The test units shall have, before starting the test, an actual capacity C_a of at least C_{rt} (3 h - 1.75 Vpc at the selected reference temperature) and be fully charged.
- 4.19.4 The unbalanced string overdischarge test shall be carried out with four fully charged cells or monoblocs.
- 4.19.5 One of the four units shall be discharged, at a unit temperature of 18 °C to 27 °C, with a current of I_{10} for 3 h hours and then connected to the remaining 3 fully charged units in series with intercell connectors giving, between each units, an air gap of 10mm or as specified in the appropriate technical documentation of the product range.
- 4.19.6 This string of units shall then be discharged, with all unit temperatures between 18 °C to 27 °C, with a current $I=I_{10}$ until the voltage of the three, initially fully charged units reaches a total of $3 \times n \times 1.80$ Vpc where n is the number of cells per unit.
- 4.19.7 After the discharge and a $24 \text{ h} \pm 0.1 \text{ h}$ stand in the discharged state, the units shall be recharged for with a current limited to $I=2.0I_{10}$ and a voltage limited to the float voltage specified by the manufacturer for either 20 °C or 25 °C.

4.19.8 At the end of the $168 \text{ h} \pm 0.1 \text{ h}$ of charge, the units shall be subjected immediately, as a four unit string, to a capacity test with a constant current of $I=I_3$ to $3 \times n \times 1.75 \text{ Vpc}$ and the capacity C_{aod} corrected to $20 \text{ }^\circ\text{C}$ or $25 \text{ }^\circ\text{C}$.

4.19.9 The capacity C_{aod} of the string shall be reported as a percentage of rated capacity C_{rt} . (3 h - 1.75 Vpc at the selected reference temperature)

$$C_{\text{aod}} \% = (C_{\text{aod}} \times 100) / C_{\text{rt}}$$

NOTE

This value C_{aod} represents the capacity available, after recharge, when cells and monoblocs with irregular initial capacity are subjected to a full discharge at a low rate.

4.19.10 The cyclic overdischarge test shall be carried out with three fully charged units.

4.19.11 The units shall be discharged, with all unit temperatures between $18 \text{ }^\circ\text{C}$ to $27 \text{ }^\circ\text{C}$ and with a constant current of $I=I_{10}$ to a voltage of $3 \times n \times 1.25 \text{ Vpc}$ where n is the number of cells per unit.

4.19.12 After the discharge and a $1 \text{ h} \pm 0.1 \text{ h}$ stand in the discharged state, the units shall be recharged for $168 \text{ h} \pm 0.1 \text{ h}$ with a current limited to $I=2.0I_{10}$ and a voltage limited to the float voltage specified by the manufacturer for either $20 \text{ }^\circ\text{C}$ or $25 \text{ }^\circ\text{C}$.

4.19.13 The sequence outlined above shall be repeated 5 times or as specified (see Section 2 of IEC 60896-2 being drafted separately).

4.19.14 At the end of the fifth $168 \text{ h} \pm 0.1 \text{ h}$ of charge, the units shall be subjected immediately to a capacity test with a constant current of $I=I_3$ to $3 \times n \times 1.75 \text{ Vpc}$ and the capacity C_{aoc} corrected to $20 \text{ }^\circ\text{C}$ or $25 \text{ }^\circ\text{C}$.

4.19.15 The capacity C_{aoc} of each unit shall be reported as a percentage of rated capacity C_{rt} . (3 h - 1.75 Vpc at the selected reference temperature)

$$C_{\text{aoc}} \% = (C_{\text{aoc}} \times 100) / C_{\text{rt}}$$

4.19.16 The individual, the average and the three standard deviations value of C_{aoc} shall be reported.

NOTE

This test is designed to replicate abusive operating conditions encountered in the field with "abusive over-discharge" conditions. Its listing does not intent to encourage the battery operator to routinely plan for such service conditions, but if it does occur, the subsequent performance of the cells and monoblocs can be predicted.

4.20 Thermal runaway sensitivity

4.20.1 The test shall be carried out with four cells or four monoblocs.

4.20.2 The test units shall be selected and prepared according to clause 3.2.

4.20.3 The test units shall have, before starting the test, an actual capacity C_a of at least C_{rt} (3 h - 1.75 Vpc at the selected reference temperature) and be fully charged.

4.20.4 The units shall be assembled with the intercell connectors as specified in the appropriate technical documentation of the product range and the test configuration and associated distances reported.

NOTE

As a part of commissioning tests users may require the test to be repeated with a fixed distance like 5 or 10 mm between adjacent units.

4.20.5 The ambient temperature shall be between 20°C to $25 \text{ }^\circ\text{C}$ during the test and any forced airflow over the units shall be slower than $0.5 \text{ m}\cdot\text{s}^{-1}$.

4.20.6 Temperature probes with a resolution of 1°C and allowing a continuous registration of the temperature (interval between temperature measurements <0.1h) shall be installed as follows (see also Fig. 6 and 7 below):

- a) One probe in contact with the surface of the negative terminal of the string
- b) One probe in the air at distance of 100mm from the string
- c) One probe in the air gap inside the string

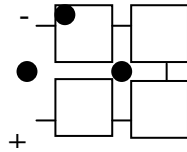

Fig. 6 Top view of the arrangement for monoblocs and single cells

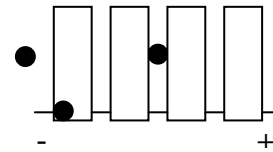

Fig. 7 Top view of the arrangement for front access monoblocs

4.20.7 The string shall be charged with a source of DC current and with a voltage as specified. The current flowing through the string shall be monitored with an appropriate resolution at an interval between measurements of < 0.1h.

4.20.8 The constant charge voltage, measured at the terminals of the string, shall be $n \times 2.45 \text{ Vpc} \pm 0.01 \text{ Vpc}$ throughout the test, where n is the number of cells in the string.

4.20.9 The elapsed time of charge to a temperature of $50 \text{ }^\circ\text{C} \pm 1 \text{ }^\circ\text{C}$ measured with the probe a) at the surface of the negative terminal of the string shall be reported.

4.20.10 A new string shall to then be readied according to 4.20.1 to 4.20.6.

4.20.11 The constant charge voltage, measured at the terminals of the string, shall be $n \times 2.60 \text{ Vpc} \pm 0.01 \text{ Vpc}$ throughout the test, where n is the number of cells in the string.

4.20.12 The elapsed time of charge to a temperature of $50 \text{ }^\circ\text{C} \pm 1 \text{ }^\circ\text{C}$ measured with the probe a) at the surface of the negative terminal of the string shall be reported.

4.20.13 At the conclusion of both tests the experimental data shall be assembled and presented as follows:

- a) Duration of charge until $50 \text{ }^\circ\text{C} \pm 1 \text{ }^\circ\text{C}$ is reached with 2.45 Vpc
- b) Duration of charge until $50 \text{ }^\circ\text{C} \pm 1 \text{ }^\circ\text{C}$ is reached with 2.60 Vpc
- c) Graphic or trace of the temperatures recorded by probes a, b and c during both experiments
- d) Graphic or trace of string current during both experiments

NOTE

This test is designed to allow the comparison of different cell and monoblocs designs under reproducible test conditions. A sensitivity to thermal runaway should be deduced not only from the time to 50°C but also from the speed in which a temperature rise in the critical 40°C to 50°C range occurs together with the associated current rise and the temperature differential between battery and outside air.

The test does not pretend to replicate all conditions leading to thermal runaway.

4.21 Low temperature service

4.21.1 The test shall be carried out with three cells or three monoblocs.

4.21.2 The test units shall be selected and prepared according to clause 3.2.

4.21.3 The test units shall have, before starting the test, an actual capacity C_a of at least C_{rt} (3 h - 1.75 Vpc at the selected reference temperature) and be fully charged.

4.21.4 The units shall be discharged with a current of $I=I_{10}$ to 1.80 Vpc at an unit temperature between 18 °C and 27 °C and the actual capacity C_a , corrected to 20 °C or 25 °C, recorded.

4.21.5 The discharged unit shall then be placed in a test chamber with a forced flow of air having a temperature of $-18\text{ }^{\circ}\text{C} \pm 2\text{ }^{\circ}\text{C}$.

4.21.6 After $72\text{ h} \pm 1\text{ h}$ of residence in the test chamber the units shall be withdrawn from the test chamber and, after $1\text{ h} \pm 0.1\text{ h}$ of stand at open circuit, charged in a room with an ambient temperature between $+18^{\circ}$ to $+27^{\circ}\text{C}$ for $168\text{ h} \pm 0.1\text{ h}$ with a current limited to $I=2.0I_{10}$ and a voltage limited to the float voltage specified by the manufacturer for either 20° or 25°C .

4.21.7 The units shall then be discharged with a current of $I=I_{10}$ to 1.80 Vpc and the actual capacity C_a corrected to $20\text{ }^{\circ}\text{C}$ or $25\text{ }^{\circ}\text{C}$ shall be recorded.

4.21.8 The capacity C_{als} of each unit shall be reported as percent of rated capacity C_{rt} . (10 h - 1.80 Vpc at the selected reference temperature)

$$C_{als}\ \% = (C_{als} \times 100) / C_{rt}$$

4.21.9 The individual, the average and the three standard deviations value of C_{als} shall be reported.

4.21.10 The sequence 4.21.4 to 4.21.7 shall be repeated at least once or as specified (see Section 2 of IEC 60896-2 being drafted separately),

NOTE

This test reflects the increased installation of batteries in uncontrolled temperature environments where power outages can cause a full battery discharge with associated prolonged low temperature stand and unavailability of power for recharge.

4.22 Dimensional stability at elevated internal pressures and temperatures

4.22.1 The test shall be carried out with one cell or one monobloc.

4.22.2 The test unit shall be selected and prepared according to clause 3.2.

4.22.3 The test unit shall have, before starting the test, an actual capacity C_a of at least C_{rt} (3 h - 1.75 Vpc at the selected reference temperature) and be fully charged. In addition the test unit shall have all the housing and structural accessories required by the manufacturer to be used in every installation.

NOTE

Housing and structural accessories are incorporated into the battery design by some manufacturers to maintain the dimensional stability of cells or monoblocs, to facilitate installation and as an aid to thermal management. Examples are steel trays or boxes and compression plates.

4.22.4 The test unit shall be adapted such as to be capable to be pressurized in all interior volumes to two times the maximum valve opening pressure present in units and as specified by the manufacturer.

4.22.5 The maximum outside dimension e.g. the girth of the cell case shall be measured before pressurization and recorded.

4.22.6 The pressurized unit shall be placed into a chamber with recirculating air at a temperature of $50\text{ }^{\circ}\text{C} \pm 2\text{ }^{\circ}\text{C}$.

4.22.7 After $24\text{ h} \pm 0.1\text{ h}$ of residence in the test chamber and under pressure, the maximum outside dimension e.g. the girth of the cell case shall be measured and recorded.

4.22.8 The increase to the cell case girth after $24\text{ h} \pm 0.1\text{ h}$ at $50\text{ }^{\circ}\text{C} \pm 2\text{ }^{\circ}\text{C}$ shall be expressed as percentage deviation over the girth value before the test as also in absolute term expressed in mm.

NOTE

This test reflects battery user experience and associated concerns of removal difficulties when batteries are installed in tight places.

4.23 Stability against mechanical abuse of units during installation

4.23.1 The test shall be carried out with three cells or three monoblocs.

4.23.2 The test unit shall be selected and prepared according to clause 3.2.

4.23.3 The test unit shall have, before starting the test, an actual capacity C_a of at least C_{rt} (3 h - 1.75 Vpc at the selected reference temperature), be fully charged and with structural accessories equivalent to that present when in process of being assembled.

4.23.4 The unpacked units shall be tested according to IEC 60068-2-32 and Amdt. 2 Free Fall for resistance against leakages caused by one drop onto a concrete floor from heights as specified below:

Fall from 100mm for units weighing up to 50Kg

Fall from 50mm for units weighing between 50Kg and 100Kg

Fall from 25mm for units weighing more than 100Kg

NOTE

In the case that the stability of packed units is required to be determined then the fall height shall be 900 mm, 450 mm and 300 mm respectively.

4.23.5 The drop test conditions shall assure, with test arrangements as shown in Fig 8 and 9 below, reproducible impact points resulting in one edge drop impact and two corner impacts.

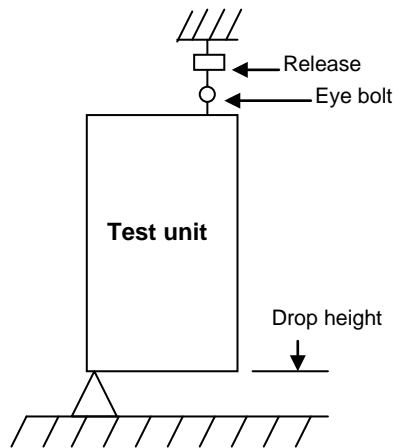

Fig. 8 Edge drop set-up

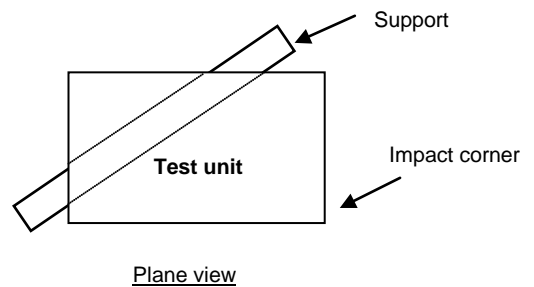

Fig 9 Corner drop set-up

4.23.6 Each of the units shall be inspected after the drop for gas and liquid leaks with adequate and sensitive means such a high voltage (2KV to 5KV) dielectric breakdown test, helium leak detectors, hydrogen detectors, pH indicator paper and the like and the findings documented and reported.

NOTE

This test is designed to detect the propensity of a cell or monobloc to fracture and leak when dropped during unpacked transport or installation. For other types of mechanical abuse adequate test shall be negotiated between the battery supplier and battery user. It is recalled that such additional test are quite expensive and, specific vibration tests, require hold downs of the battery not present during transport.